

- 150-mA Load Current Without External Power Transistor
- Adjustable Current-Limiting Capability
- Input Voltages up to 40 V
- Output Adjustable From 2 V to 37 V
- Direct Replacement for Fairchild μA723C

description

The μA723 is a precision integrated-circuit voltage regulator, featuring high ripple rejection, excellent input and load regulation, excellent temperature stability, and low standby current. The circuit consists of a temperature-compensated reference-voltage amplifier, an error amplifier, a 150-mA output transistor, and an adjustable-output current limiter.

The μA723 is designed for use in positive or negative power supplies as a series, shunt, switching, or floating regulator. For output currents exceeding 150 mA, additional pass elements can be connected as shown in Figures 4 and 5.

The μA723C is characterized for operation from 0°C to 70°C.



AVAILABLE OPTIONS

T _A	PACKAGED DEVICES		CHIP FORM (Y)
	PLASTIC DIP (N)	SMALL OUTLINE (D)	
0°C to 70°C	μA723CN	μA723CD	μA723Y

The D package is available taped and reeled. Add the suffix R to the device type (e.g., μA723CDR). Chip forms are tested at 25°C.

functional block diagram

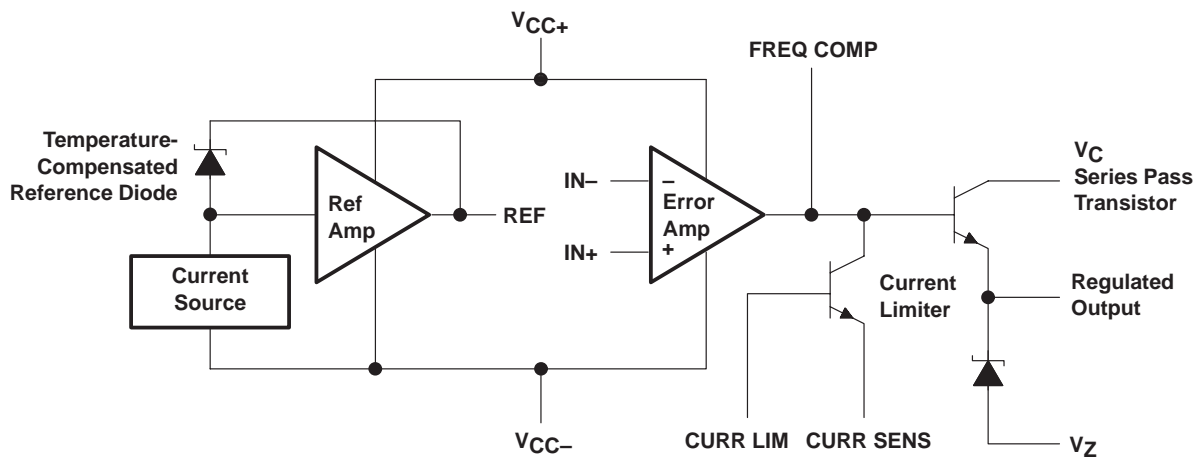

Please be aware that an important notice concerning availability, standard warranty, and use in critical applications of Texas Instruments semiconductor products and disclaimers thereto appears at the end of this data sheet.

PRODUCTION DATA information is current as of publication date. Products conform to specifications per the terms of Texas Instruments standard warranty. Production processing does not necessarily include testing of all parameters.



POST OFFICE BOX 655303 • DALLAS, TEXAS 75265

Copyright © 1999, Texas Instruments Incorporated

μA723 PRECISION VOLTAGE REGULATORS

SLVS057D – AUGUST 1972 – REVISED JULY 1999

schematic

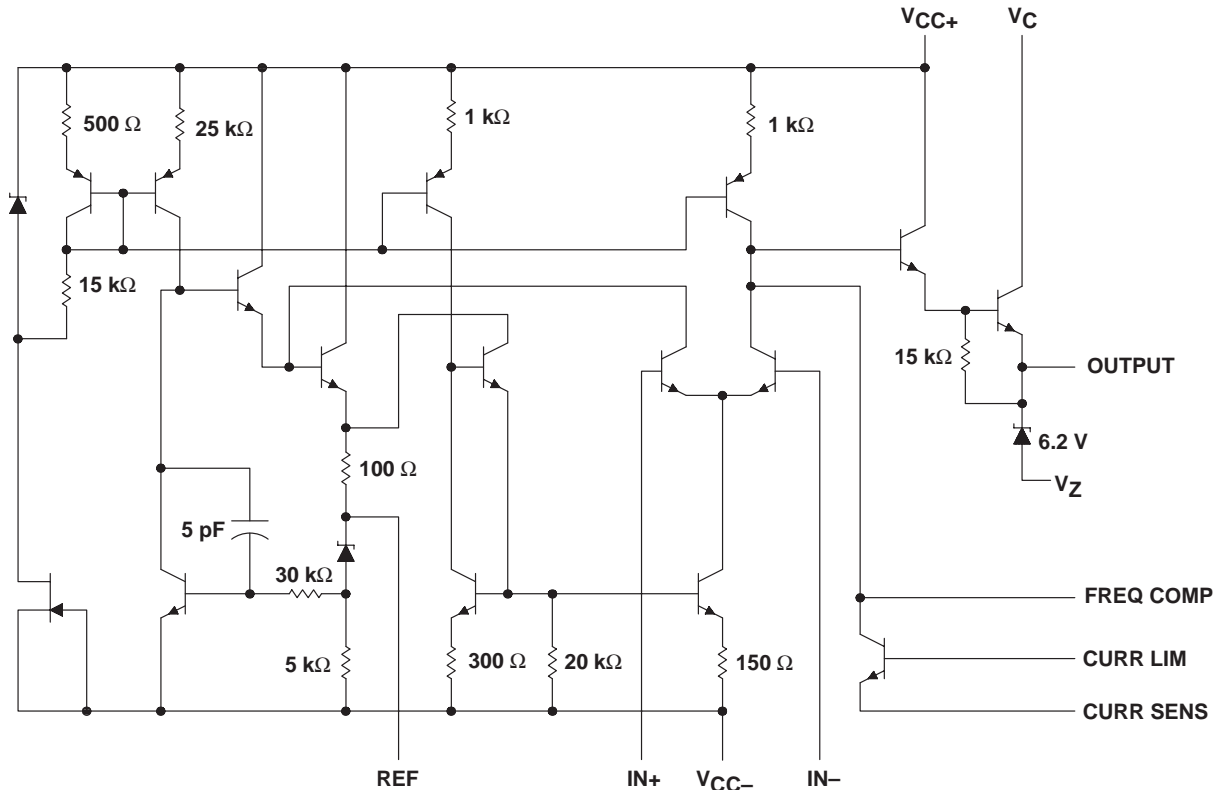

Resistor and capacitor values shown are nominal.

absolute maximum ratings over operating free-air temperature range (unless otherwise noted)[†]

Peak voltage from V_{CC+} to V_{CC-} ($t_w \leq 50$ ms)	50 V
Continuous voltage from V_{CC+} to V_{CC-}	40 V
Input-to-output voltage differential	40 V
Differential input voltage to error amplifier	± 5 V
Voltage between noninverting input and V_{CC-}	8 V
Current from V_Z	25 mA
Current from REF	15 mA
Package thermal impedance, θ_{JA} (see Notes 1 and 2): D package	86°C/W
N package	101°C/W
Lead temperature 1,6 mm (1/16 inch) from case for 10 seconds: D or N package	260°C
Storage temperature range, T_{stg}	-65°C to 150°C

[†] Stresses beyond those listed under "absolute maximum ratings" may cause permanent damage to the device. These are stress ratings only, and functional operation of the device at these or any other conditions beyond those indicated under "recommended operating conditions" is not implied. Exposure to absolute-maximum-rated conditions for extended periods may affect device reliability.

NOTES: 1. Maximum power dissipation is a function of $T_J(\max)$, θ_{JA} , and T_A . The maximum allowable power dissipation at any allowable ambient temperature is $P_D = (T_J(\max) - T_A)/\theta_{JA}$. Operating at the absolute maximum T_J of 150°C can impact reliability.
2. The package thermal impedance is calculated in accordance with JESD 51, except for through-hole packages, which use a trace length of zero.



POST OFFICE BOX 655303 • DALLAS, TEXAS 75265

recommended operating conditions

	MIN	MAX	UNIT
Input voltage, V_I	9.5	40	V
Output voltage, V_O	2	37	V
Input-to-output voltage differential, $V_C - V_O$	3	38	V
Output current, I_O		150	mA
Operating free-air temperature range, T_A	μA723C		0 70 °C

electrical characteristics at specified free-air temperature (see Notes 3 and 4)

PARAMETER	TEST CONDITIONS	T_A	μA723C			UNIT
			MIN	TYP	MAX	
Input regulation	$V_I = 12\text{ V to }V_I = 15\text{ V}$	25°C	0.1		1	mV/V
	$V_I = 12\text{ V to }V_I = 40\text{ V}$	25°C	1		5	
	$V_I = 12\text{ V to }V_I = 15\text{ V}$	0°C to 70°C			3	
Ripple rejection	f = 50 Hz to 10 kHz, $C_{ref} = 0$	25°C	74			dB
	f = 50 Hz to 10 kHz, $C_{ref} = 5\text{ }\mu\text{F}$	25°C	86			
Output regulation		25°C	-0.3	-2		mV/V
		0°C to 70°C			-6	
Reference voltage, V_{ref}		25°C	6.8	7.15	7.5	V
Standby current	$V_I = 30\text{ V}, I_O = 0$	25°C	2.3		4	mA
Temperature coefficient of output voltage		0°C to 70°C	0.003	0.015		%/°C
Short-circuit output current	$R_{SC} = 10\text{ }\Omega, V_O = 0$	25°C	65			mA
Output noise voltage	BW = 100 Hz to 10 kHz, $C_{ref} = 0$	25°C	20			μV
	BW = 100 Hz to 10 kHz, $C_{ref} = 5\text{ }\mu\text{F}$	25°C	2.5			

- NOTES: 3. For all values in this table, the device is connected as shown in Figure 1 with the divider resistance as seen by the error amplifier $\leq 10\text{ k}\Omega$. Unless otherwise specified, $V_I = V_{CC+} = V_C = 12\text{ V}$, $V_{CC-} = 0$, $V_O = 5\text{ V}$, $I_O = 1\text{ mA}$, $R_{SC} = 0$, and $C_{ref} = 0$.
4. Pulse-testing techniques must be used that will maintain the junction temperature as close to the ambient temperature as possible.

electrical characteristics, $T_A = 25^\circ\text{C}$ (see Notes 3 and 4)

PARAMETER	TEST CONDITIONS	μA723Y			UNIT
		MIN	TYP	MAX	
Input regulation	$V_I = 12\text{ V to }V_I = 15\text{ V}$	0.1			mV/V
	$V_I = 12\text{ V to }V_I = 40\text{ V}$	1			
Ripple rejection	f = 50 Hz to 10 kHz, $C_{ref} = 0$	74			dB
	f = 50 Hz to 10 kHz, $C_{ref} = 5\text{ }\mu\text{F}$	86			
Output regulation		-0.3			mV/V
Reference voltage, V_{ref}		7.15			V
Standby current	$V_I = 30\text{ V}, I_O = 0$	2.3			mA
Short-circuit output current	$R_{SC} = 10\text{ }\Omega, V_O = 0$	65			mA
Output noise voltage	BW = 100 Hz to 10 kHz, $C_{ref} = 0$	20			μV
	BW = 100 Hz to 10 kHz, $C_{ref} = 5\text{ }\mu\text{F}$	2.5			

- NOTES: 3. For all values in this table, the device is connected as shown in Figure 1 with the divider resistance as seen by the error amplifier $\leq 10\text{ k}\Omega$. Unless otherwise specified, $V_I = V_{CC+} = V_C = 12\text{ V}$, $V_{CC-} = 0$, $V_O = 5\text{ V}$, $I_O = 1\text{ mA}$, $R_{SC} = 0$, and $C_{ref} = 0$.
4. Pulse-testing techniques must be used that will maintain the junction temperature as close to the ambient temperature as possible.

APPLICATION INFORMATION

Table 1. Resistor Values (kΩ) for Standard Output Voltages

OUTPUT VOLTAGE (V)	APPLICABLE FIGURES (SEE NOTE 5)	FIXED OUTPUT ±5%		OUTPUT ADJUSTABLE ±10% (SEE NOTE 6)		
		R1 (kΩ)	R2 (kΩ)	R1 (kΩ)	P1 (kΩ)	P2 (kΩ)
3.0	1, 5, 6, 9, 11, 12 (4)	4.12	3.01	1.8	0.5	1.2
3.6	1, 5, 6, 9, 11, 12 (4)	3.57	3.65	1.5	0.5	1.5
5.0	1, 5, 6, 9, 11, 12 (4)	2.15	4.99	0.75	0.5	2.2
6.0	1, 5, 6, 9, 11, 12 (4)	1.15	6.04	0.5	0.5	2.7
9.0	2, 4, (5, 6, 9, 12)	1.87	7.15	0.75	1.0	2.7
12	2, 4, (5, 6, 9, 12)	4.87	7.15	2.0	1.0	3.0
15	2, 4, (5, 6, 9, 12)	7.87	7.15	3.3	1.0	3.0
28	2, 4, (5, 6, 9, 12)	21.0	7.15	5.6	1.0	2.0
45	7	3.57	48.7	2.2	10	39
75	7	3.57	78.7	2.2	10	68
100	7	3.57	105	2.2	10	91
250	7	3.57	255	2.2	10	240
-6 (see Note 7)	3, 10	3.57	2.43	1.2	0.5	0.75
-9	3, 10	3.48	5.36	1.2	0.5	2.0
-12	3, 10	3.57	8.45	1.2	0.5	3.3
-15	3, 10	3.57	11.5	1.2	0.5	4.3
-28	3, 10	3.57	24.3	1.2	0.5	10
-45	8	3.57	41.2	2.2	10	33
-100	8	3.57	95.3	2.2	10	91
-250	8	3.57	249	2.2	10	240

- NOTES: 5. The R1/R2 divider can be across either V_O or $V_{(ref)}$. If the divider is across $V_{(ref)}$, use the figure numbers without parentheses. If the divider is across V_O , use the figure numbers in parentheses.
 6. To make the voltage adjustable, the R1/R2 divider shown in the figures must be replaced by the divider shown below.

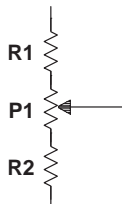

Adjustable Output Circuit

7. For Figures 3, 8, and 10, the device requires a minimum of 9V between V_{CC+} and V_{CC-} when V_O is equal to or more positive than -9 V.

APPLICATION INFORMATION

Table 2. Formulas for Intermediate Output Voltages

OUTPUTS FROM 2 V TO 7 V SEE FIGURES 1, 5, 6, 9, 11, 12 (4) AND NOTE 5	OUTPUTS FROM 4 V TO 250 V SEE FIGURE 7 AND NOTE 5	CURRENT LIMITING
$V_O = V_{(ref)} \times \frac{R_2}{R_1 + R_2}$	$V_O = \frac{V_{(ref)}}{2} \times \frac{R_2 - R_1}{R_1}$ $R_3 = R_4$	$I_{(limit)} \approx \frac{0.65 \text{ V}}{R_{SC}}$
OUTPUTS FROM 7 V TO 37 V SEE FIGURES 2, 4, (5, 6, 9, 11, 12) AND NOTE 5	OUTPUTS FROM -6 V TO -250 V SEE FIGURES 3, 8, 10 AND NOTES 5 AND 7	FOLDBACK CURRENT LIMITING SEE FIGURE 6
$V_O = V_{(ref)} \times \frac{R_1 + R_2}{R_2}$	$V_O = -\frac{V_{(ref)}}{2} \times \frac{R_1 + R_2}{R_1}$ $R_3 = R_4$	$I_{(knee)} \approx \frac{V_O R_3 + (R_3 + R_4) 0.65 \text{ V}}{R_{SC} R_4}$ $I_{OS} \approx \frac{0.65 \text{ V}}{R_{SC}} \times \frac{R_3 + R_4}{R_4}$

- NOTES: 5. The R1/R2 divider can be across either V_O or $V_{(ref)}$. If the divider is across $V_{(ref)}$, use figure numbers without parentheses. If the divider is across V_O , use the figure numbers in parentheses.
7. For Figures 3, 8, and 10, the device requires a minimum of 9 V between V_{CC+} and V_{CC-} when V_O is equal to or more positive than -9 V.

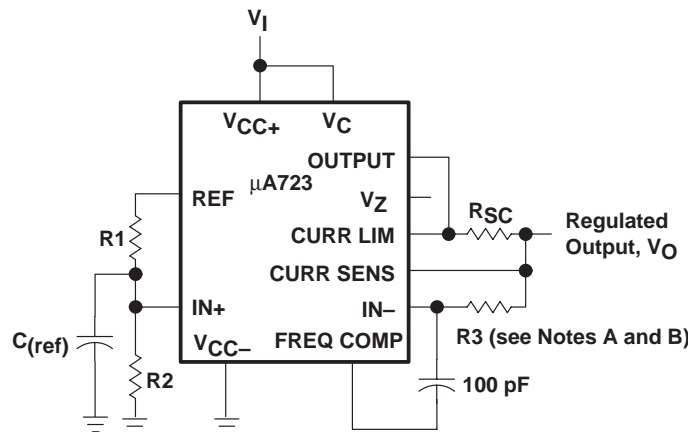

- NOTES: A. $R_3 = \frac{R_1 \times R_2}{R_1 + R_2}$ for a minimum α_{V_O}
- B. R_3 can be eliminated for minimum component count. Use direct connection (i.e., $R_3 = 0$).

Figure 1. Basic Low-Voltage Regulator ($V_O = 2 \text{ V to } 7 \text{ V}$)

APPLICATION INFORMATION

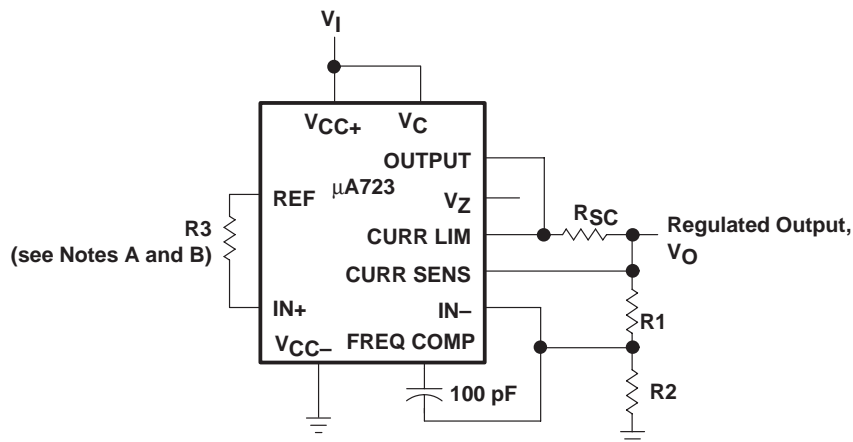

- NOTES: A. $R_3 = \frac{R_1 \times R_2}{R_1 + R_2}$ for a minimum α_{V_O}
 B. R_3 can be eliminated for minimum component count. Use direct connection (i.e., $R_3 = 0$).

Figure 2. Basic High-Voltage Regulator ($V_O = 7\text{ V to }37\text{ V}$)

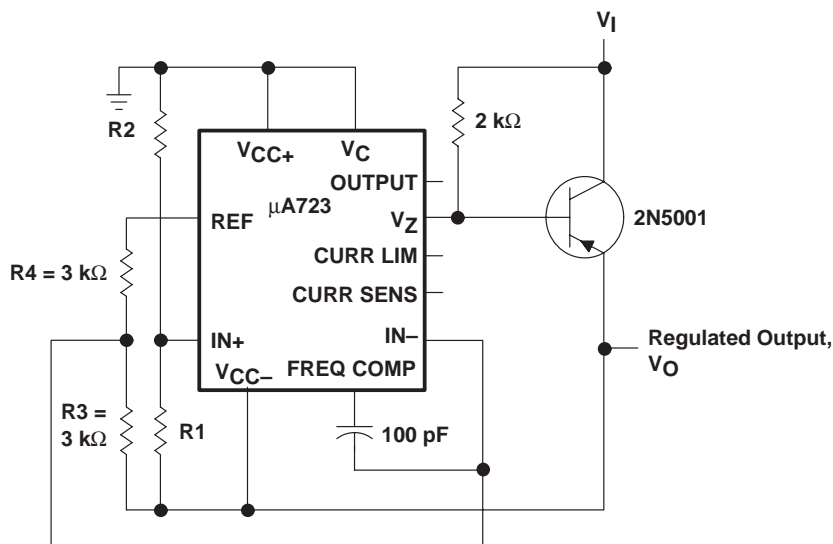

Figure 3. Negative-Voltage Regulator

APPLICATION INFORMATION

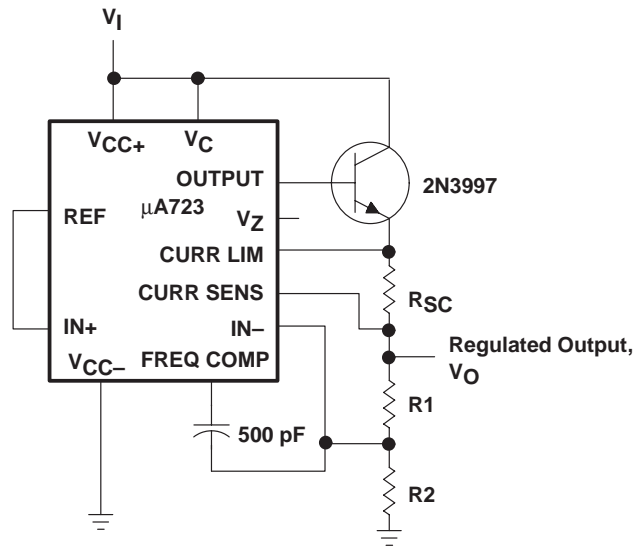

Figure 4. Positive-Voltage Regulator (External npn Pass Transistor)



Figure 5. Positive-Voltage Regulator (External pnp Pass Transistor)

APPLICATION INFORMATION

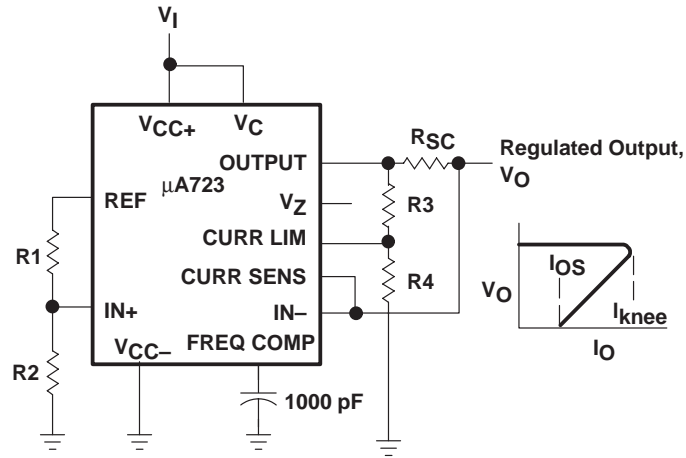

Figure 6. Foldback Current Limiting

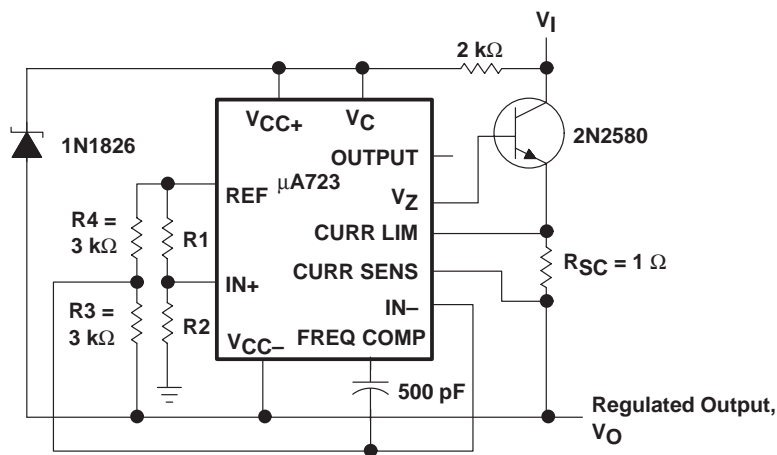

Figure 7. Positive Floating Regulator

APPLICATION INFORMATION

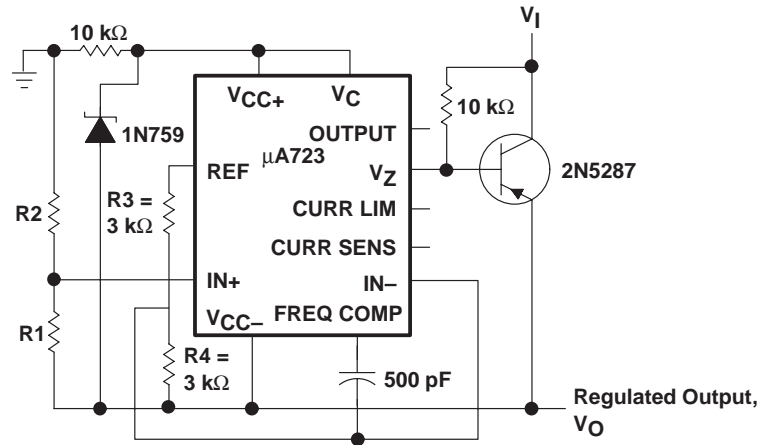
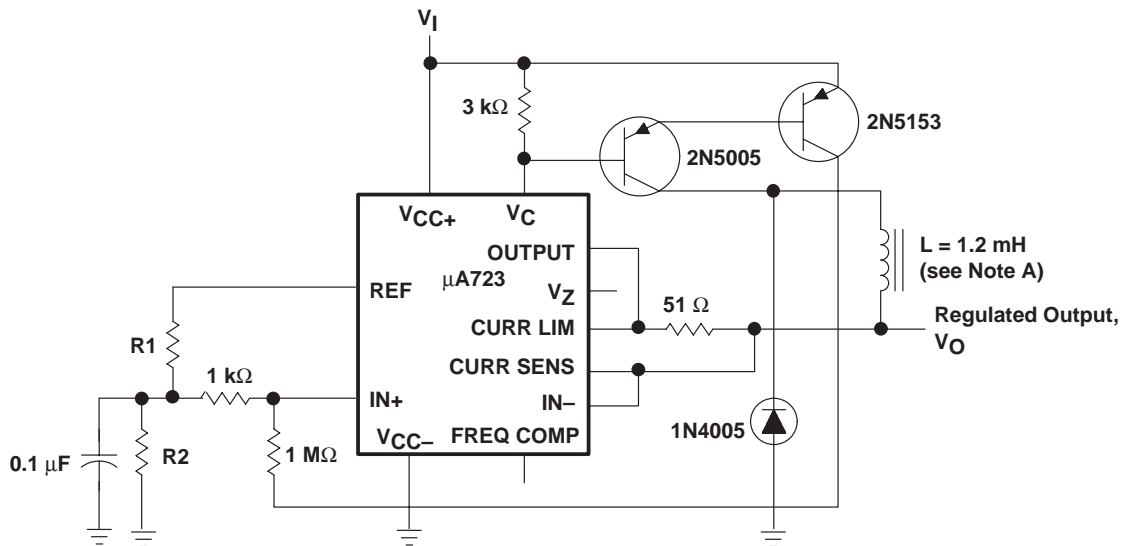

Figure 8. Negative Floating Regulator



NOTE A: L is 40 turns of No. 20 enameled copper wire wound on Ferroxcube P36/22-3B7 potted core, or equivalent, with a 0.009-inch air gap.

Figure 9. Positive Switching Regulator

APPLICATION INFORMATION

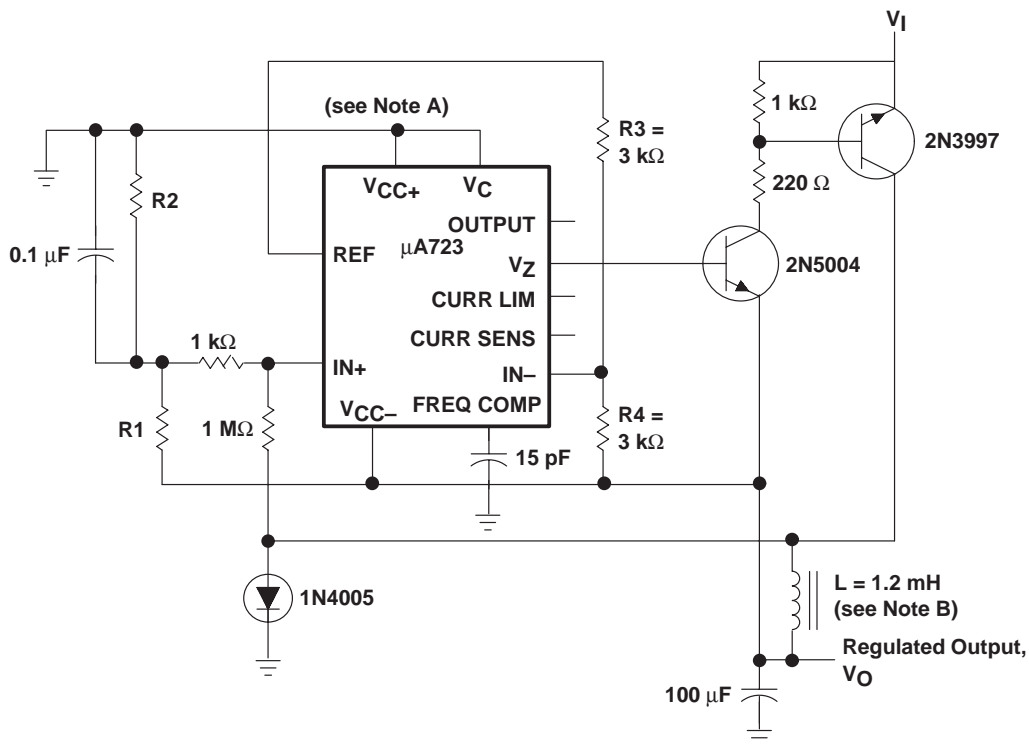

- NOTES: A. The device requires a minimum of 9 V between V_{CC+} and V_{CC-} when V_O is equal to or more positive than -9 V.
 B. L is 40 turns of No. 20 enameled copper wire wound on Ferroxcube P36/22-3B7 potted core, or equivalent, with a 0.009-inch air gap.

Figure 10. Negative Switching Regulator

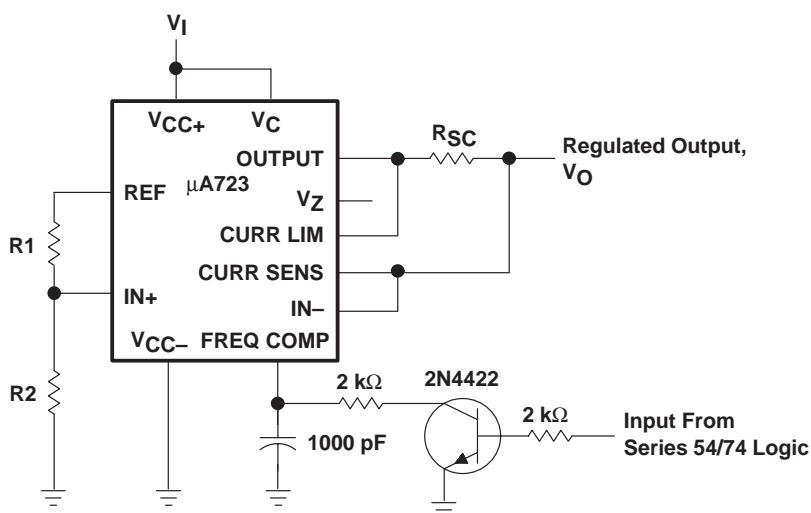

NOTE A: A current-limiting transistor can be used for shutdown if current limiting is not required.

Figure 11. Remote Shutdown Regulator With Current Limiting

APPLICATION INFORMATION

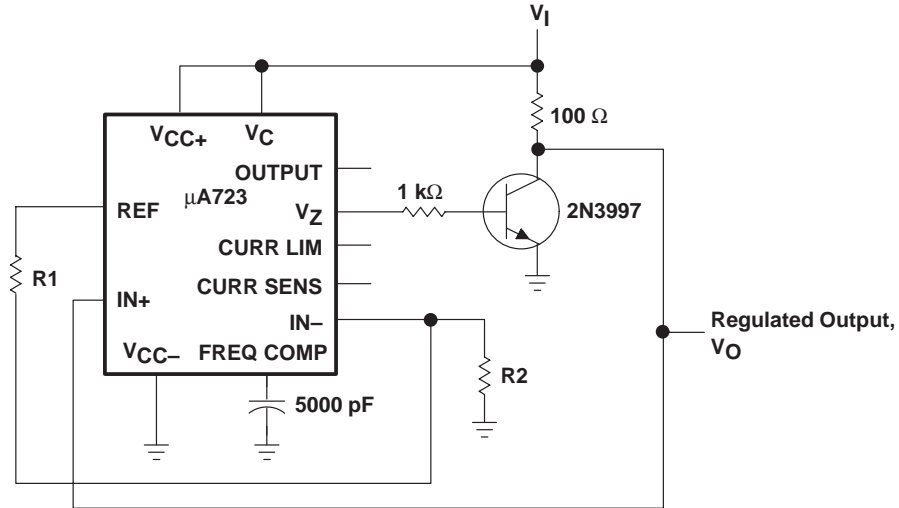

Figure 12. Shunt Regulator

IMPORTANT NOTICE

Texas Instruments and its subsidiaries (TI) reserve the right to make changes to their products or to discontinue any product or service without notice, and advise customers to obtain the latest version of relevant information to verify, before placing orders, that information being relied on is current and complete. All products are sold subject to the terms and conditions of sale supplied at the time of order acknowledgement, including those pertaining to warranty, patent infringement, and limitation of liability.

TI warrants performance of its semiconductor products to the specifications applicable at the time of sale in accordance with TI's standard warranty. Testing and other quality control techniques are utilized to the extent TI deems necessary to support this warranty. Specific testing of all parameters of each device is not necessarily performed, except those mandated by government requirements.

CERTAIN APPLICATIONS USING SEMICONDUCTOR PRODUCTS MAY INVOLVE POTENTIAL RISKS OF DEATH, PERSONAL INJURY, OR SEVERE PROPERTY OR ENVIRONMENTAL DAMAGE ("CRITICAL APPLICATIONS"). TI SEMICONDUCTOR PRODUCTS ARE NOT DESIGNED, AUTHORIZED, OR WARRANTED TO BE SUITABLE FOR USE IN LIFE-SUPPORT DEVICES OR SYSTEMS OR OTHER CRITICAL APPLICATIONS. INCLUSION OF TI PRODUCTS IN SUCH APPLICATIONS IS UNDERSTOOD TO BE FULLY AT THE CUSTOMER'S RISK.

In order to minimize risks associated with the customer's applications, adequate design and operating safeguards must be provided by the customer to minimize inherent or procedural hazards.

TI assumes no liability for applications assistance or customer product design. TI does not warrant or represent that any license, either express or implied, is granted under any patent right, copyright, mask work right, or other intellectual property right of TI covering or relating to any combination, machine, or process in which such semiconductor products or services might be or are used. TI's publication of information regarding any third party's products or services does not constitute TI's approval, warranty or endorsement thereof.



>> [Semiconductor Home](#) > [Products](#) > [Analog & Mixed-Signal](#) > [Power Management](#) > [Linear Regulation](#) > [Standard Voltage Regulators](#) >

UA723, PRECISION VOLTAGE REGULATOR

Device Status: Active

- > [Description](#)
- > [Features](#)
- > [Datasheets](#)
- > [Pricing/Samples/Availability](#)
- > [Application Notes](#)
- > [Development Tools](#)
- > [Applications](#)

Parameter Name	UA723
VIN (max) (V)	40
VO Adjustable (nom) (V)	2 - 37
Tolerance (%)	1
Shutdown	No
Vdo (max) (V)	3
Iq (typ) (mA)	2.3
SVS	No
Io (max) (mA)	150

Description

The uA723 is a precision integrated-circuit voltage regulator, featuring high ripple rejection, excellent input and load regulation, excellent temperature stability, and low standby current. The circuit consists of a temperature-compensated reference-voltage amplifier, an error amplifier, a 150-mA output transistor, and an adjustable-output current limiter.

The uA723 is designed for use in positive or negative power supplies as a series, shunt, switching, or floating regulator. For output currents exceeding 150 mA, additional pass elements can be connected as shown in Figures 4 and 5.

The uA723C is characterized for operation from 0°C to 70°C.

Features

- 150-mA Load Current Without External Power Transistor
- Adjustable Current-Limiting Capability
- Input Voltages up to 40 V
- Output Adjustable From 2 V to 37 V
- Direct Replacement for Fairchild uA723C

To view the following documents, [Acrobat Reader 3.x](#) is required.

To download a document to your hard drive, right-click on the link and choose 'Save'.

Datasheets

Full datasheet in Acrobat PDF: [slvs057d.pdf](#) (175 KB)

Full datasheet in Zipped PostScript: [slvs057d.psz](#) (161 KB)

Pricing/Samples/Availability

Orderable Device	Package	Pins	Temp (°C)	Status	Price/unit USD (100-999)	Pack Qty	Availability / Samples
UA723CD	D	14		ACTIVE	0.62	50	Check stock or order
UA723CDR	D	14		ACTIVE	0.55	2500	Check stock or order
UA723CJ	J	14		LIFEBUY			Check stock or order
UA723CN	N	14		ACTIVE	0.62	25	Check stock or order
UA723CNS	NS	14		ACTIVE			Check stock or order

Application Reports

- [ANALOG APPLICATIONS JOURNAL \(SLYT010A\)](#)
- [ANALOG APPLICATIONS JOURNAL \(SLYT012A, 782 KB\)](#)
- [ELECTROSTATIC DISCHARGE APPLICATION NOTE \(SSYA008\)](#)
- [POWERFLEX \(TM\) -- SURFACE-MOUNT ALTERNATIVE FOR THROUGH-HOLE POWER PACKAGES \(SZZA015\)](#)
- [SUPPLY VOLTAGE DROP ON FAST CURRENT DEMAND \(SLVA076\)](#)
- [THERMAL CHARACTERISTICS OF LINEAR AND LOGIC PACKAGES USING JEDEC PCB DESIGNS \(SZZA017A\)](#)

Table Data Updated on: 4/26/2000

(c) Copyright 2000 Texas Instruments Incorporated. All rights reserved.

Trademarks, Important Notice!, Privacy Policy