



MACH211-7/10/12/15/20

High-Density EE CMOS Programmable Logic

DISTINCTIVE CHARACTERISTICS

- 44 Pins
- 64 Macrocells
- 7.5 ns t_{PD} Commercial
10 ns t_{PD} Industrial
- 133 MHz f_{CNT}
- 38 Bus-Friendly inputs and I/Os
- Peripheral Component Interconnect (PCI) compliant
- Programmable power-down mode
- 32 Outputs
- 64 Flip-flops; 4 clock choices
- 4 "PAL26V16" blocks with buried macrocells
- Pin-compatible with MACH110, MACH111, MACH210, and MACH215
- Improved routing over the MACH210

GENERAL DESCRIPTION

The MACH211 is a member of AMD's EE CMOS Performance Plus MACH 2 device family. This device has approximately six times the logic macrocell capability of the popular PAL22V10 without loss of speed.

The MACH211 consists of four PAL blocks interconnected by a programmable switch matrix. The four PAL blocks are essentially "PAL26V16" structures complete with product-term arrays and programmable macrocells, which can be programmed as high speed or low power, and buried macrocells. The switch matrix connects the PAL blocks to each other and to all input pins, providing a high degree of connectivity between the fully-connected PAL blocks. This allows designs to be placed and routed efficiently.

The MACH211 has two kinds of macrocell: output and buried. The MACH211 output macrocell provides registered, latched, or combinatorial outputs with programmable polarity. If a registered configuration is chosen, the register can be configured as D-type or T-type to help reduce the number of product terms. The register type decision can be made by the designer or by the software. All output macrocells can be connected to an I/O cell. If a buried macrocell is desired, the internal feedback path from the macrocell can be used, which frees up the I/O pin for use as an input.

The MACH211 has dedicated buried macrocells which, in addition to the capabilities of the output macrocell, also provide input registers or latches for use in synchronizing signals and reducing setup time requirements.

BLOCK DIAGRAM

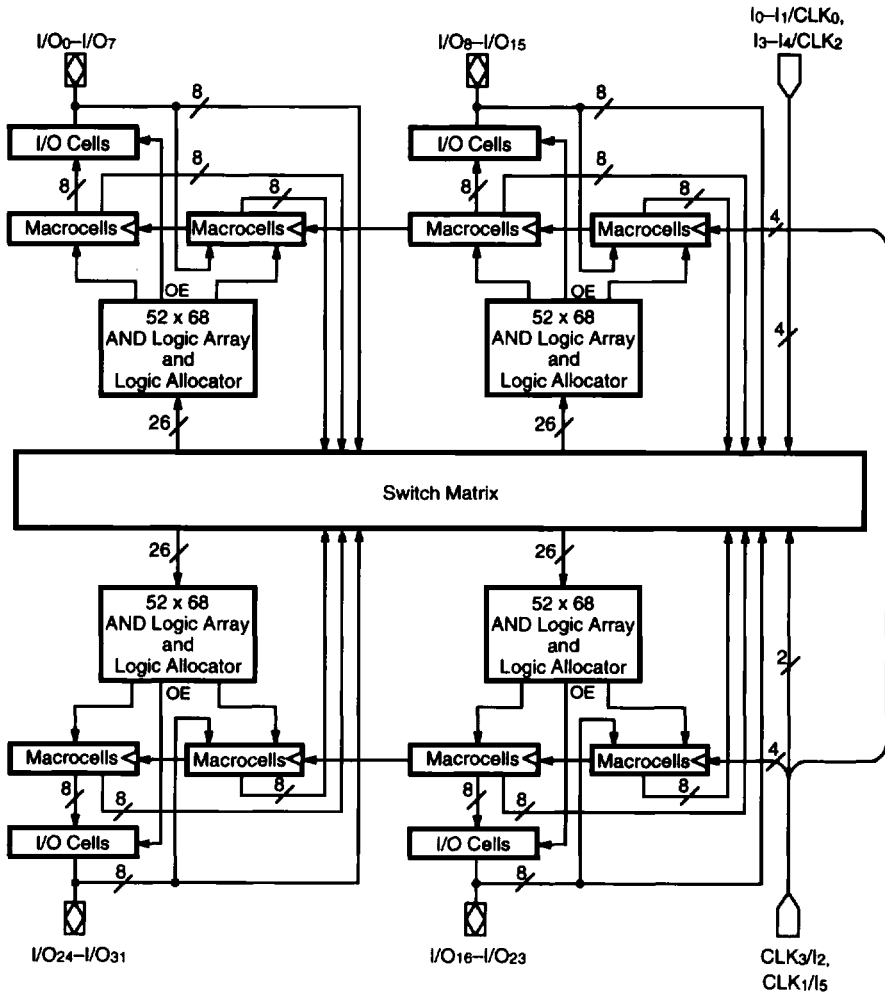

19601B-1