

CD54/74HC4351, CD54/74HCT4351
CD54/74HC4352, CD54/74HCT4352
CD54/74HC4353, CD54/74HCT4353

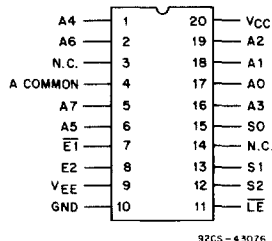

92CS - 43076
CD54/74HC/HCT4351
TERMINAL ASSIGNMENT

Analog Multiplexers/Demultiplexers With Latch

Type Features:

- Wide analog input voltage range: $\pm 5\text{ V max.}$
- Low "on" resistance:
 $70\ \Omega$ type ($V_{CC}-V_{EE} = 4.5\text{ V}$)
 $40\ \Omega$ type ($V_{CC}-V_{EE} = 9\text{ V}$)
- Low crosstalk between switches
- Fast switching and propagation speeds
- "Break-before-make" switching

The RCA CD54/74HC/HCT4351, 4352, and 4353 are digitally controlled analog switches which utilize silicon-gate CMOS technology to achieve operating speeds similar to LSTTL with the low power consumption of standard CMOS integrated circuits.

These analog multiplexers/demultiplexers are, in essence, the HC/HCT4051, 4052, and 4053 preceded by address latches that are controlled by an active low Latch Enable input (LE). Two Enable inputs, one active low (E1), and the other active high (E2) are provided allowing enabling with either input voltage level.

The CD54HC/HCT4351, 4352, and 4353 are supplied in 20-lead hermetic dual-in-line ceramic packages (F suffix). The CD74HC/HCT4351, 4352, and 4353 are supplied in 20-lead plastic packages (E suffix) and in 20-lead surface mount plastic packages (M suffix). All devices are also available in chip form (H suffix).

Family Features:

- Wide Operating Temperature Range:
 CD74HC/HCT: $-40^\circ\text{C to }+125^\circ\text{C}$
- Alternate Source is Philips/Signetics
- CD54HC/CD74HC Types:
 $2\text{ to }6\text{ V Operation, control; }0\text{ to }10\text{ V, switch}$
 High Noise Immunity:
 $N_{IL} = 30\%, N_{IH} = 30\%$ of V_{CC} ; @ $V_{CC} = 5\text{ V}$
- CD54HCT/CD74HCT Types:
 $4.5\text{ to }5.5\text{ V Operation, control; }0\text{ to }10\text{ V, switch}$
 Direct LSTTL Input Logic Compatibility
 $V_{IL} = 0.8\text{ V Max.}, V_{IH} = 2\text{ V Min.}$
 CMOS Input Compatibility
 $I_L \leq 1\ \mu\text{A @ }V_{OL}, V_{OH}$

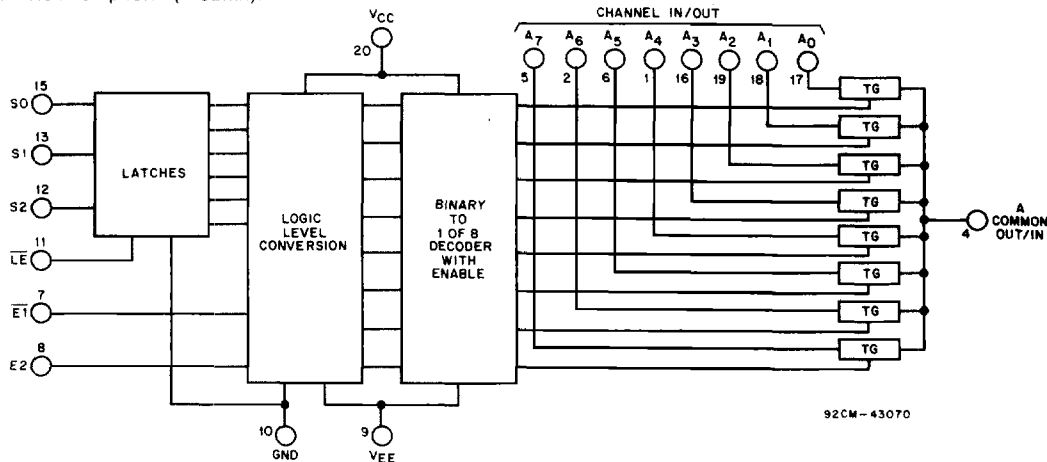

Fig. 1 - Functional diagram of HC/HCT4351.

CD54/74HC4351, CD54/74HCT4351
CD54/74HC4352, CD54/74HCT4352
CD/74HC4353, CD54/74HCT4353

TRUTH TABLE
CD54/74HC/HCT4351

INPUT STATES					"ON" SWITCHES $\overline{LE} = H^*$
$\overline{E1}$	E2	S2	S1	S0	
L	H	L	L	L	A ₀
L	H	L	L	H	A ₁
L	H	L	H	L	A ₂
L	H	L	H	H	A ₃
L	H	H	L	L	A ₄
L	H	H	L	H	A ₅
L	H	H	H	L	A ₆
L	H	H	H	H	A ₇
H	L	X	X	X	None

X = Don't Care.

* When \overline{LE} is low S0-S2 data are latched and switches cannot change state.

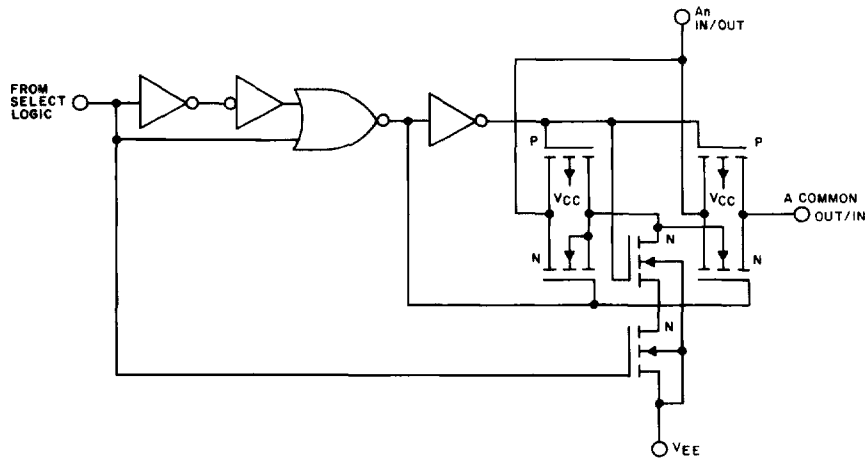

92CM-43071

Fig. 2 - Detail of one HC/HCT4351 switch.

CD54/74HC4351, CD54/74HCT4351
CD54/74HC4352, CD54/74HCT4352
CD54/74HC4353, CD54/74HCT4353

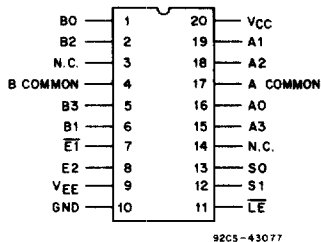

CD54/74HC/HCT4352
TERMINAL ASSIGNMENT

TRUTH TABLE
CD54/74HC/HCT4352

INPUT STATES				"ON" CHANNELS $\overline{LE} = H^*$
$\overline{E1}$	E2	S1	S0	
L	H	L	L	A ₀ , B ₀
L	H	L	H	A ₁ , B ₁
L	H	H	L	A ₂ , B ₂
L	H	H	H	A ₃ , B ₃
H	L	X	X	None

X = Don't Care.

* When Latch Enable is "Low" channel-select data is latched and switches cannot change state.

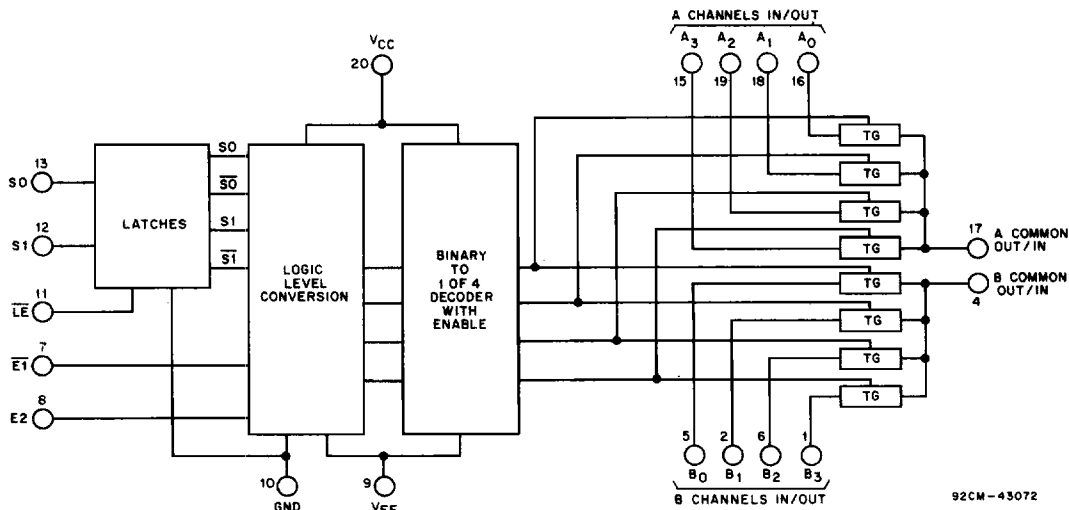

Fig. 3 - Functional diagram of HC/HCT4352.

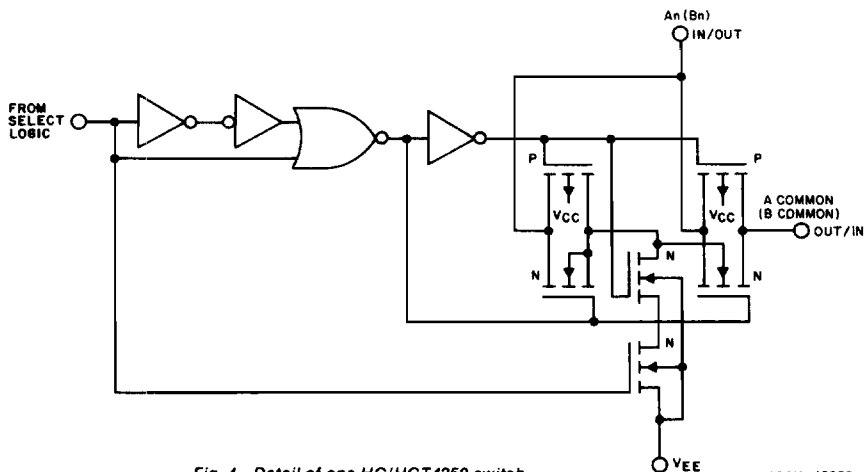
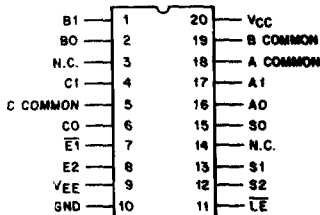

Fig. 4 - Detail of one HC/HCT4352 switch.

**CD54/74HC4351, CD54/74HCT4351
CD54/74HC4352, CD54/74HCT4352
CD54/74HC4353, CD54/74HCT4353**

TRUTH TABLE CD54/74HC/HCT4353

INPUT STATES					"ON" CHANNELS LE = H *
$\overline{E1}$	E2	S2	S1	S0	
L	H	L	L	L	C ₀ , B ₀ , A ₀
L	H	L	L	H	C ₀ , B ₀ , A ₁
L	H	L	H	L	C ₀ , B ₁ , A ₀
L	H	L	H	H	C ₀ , B ₁ , A ₁
L	H	H	L	L	C ₁ , B ₀ , A ₀
L	H	H	L	H	C ₁ , B ₀ , A ₁
L	H	H	H	L	C ₁ , B ₁ , A ₀
L	H	H	H	H	C ₁ , B ₁ , A ₁
H	X	X	X	X	None
X	L	X	X	X	None



**CD54/74HC/HCT4353
TERMINAL ASSIGNMENT**

X = Don't Care.

* When Latch Enable is "Low" channel-select data is latched and switches cannot change state.

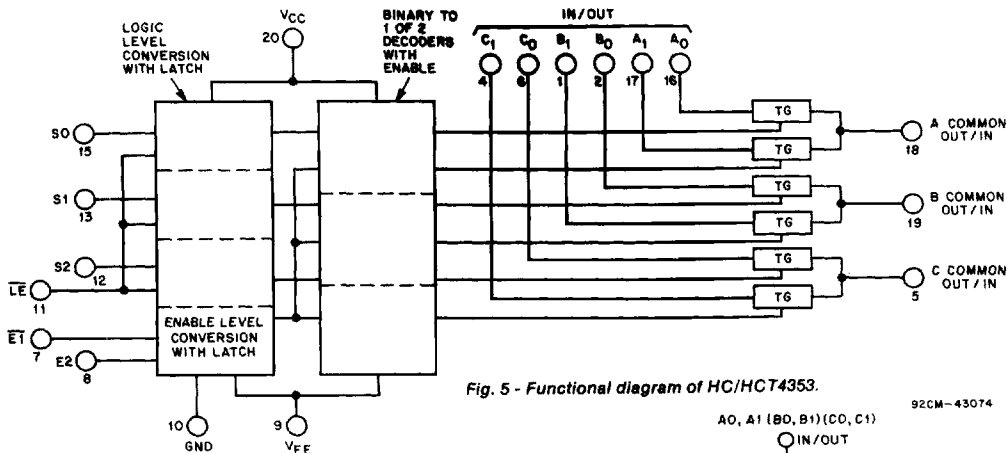

Fig. 5 - Functional diagram of HC/HCT4353.

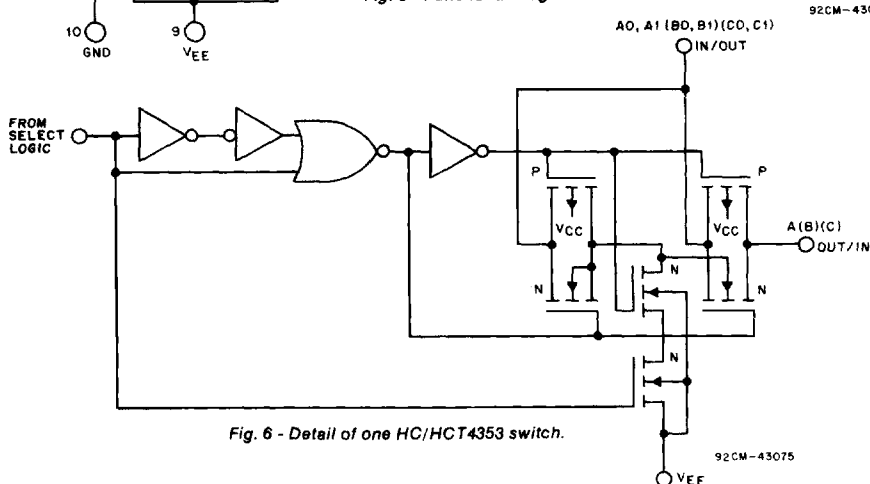

Fig. 6 - Detail of one HC/HCT4353 switch.

CD54/74HC4351, CD54/74HCT4351
CD54/74HC4352, CD54/74HCT4352
CD54/74HC4353, CD54/74HCT4353

MAXIMUM RATINGS, Absolute-Maximum Values: (All voltages referenced to Gnd unless otherwise shown)

DC SUPPLY-VOLTAGE ($V_{CC}-V_{EE}$)	-0.5 to +10.5 V
DC SUPPLY-VOLTAGE (V_{CC})	-0.5 to +7 V
DC SUPPLY-VOLTAGE (V_{EE})	+0.5 to -7 V
DC INPUT DIODE CURRENT, I_{IK} (FOR $V_i < -0.5$ V OR $V_i > V_{CC} + 0.5$ V)	± 20 mA
DC SWITCH DIODE CURRENT, I_{OK} (FOR $V_i < V_{EE} - 0.5$ V OR $V_i > V_{CC} + 0.5$ V)	± 20 mA
DC SWITCH CURRENT (FOR $V_i > V_{EE} - 0.5$ V OR $V_i < V_{CC} + 0.5$ V)	+25 mA
DC V_{CC} OR GROUND CURRENT (I_{CC})	± 50 mA
DC V_{EE} CURRENT (I_{EE})	-20 mA
POWER DISSIPATION PER PACKAGE (P_D):	
For $T_A = -40$ to $+100^\circ\text{C}$ (PACKAGE TYPE E)	500 mW
For $T_A = +100$ to $+125^\circ\text{C}$ (PACKAGE TYPE E)	Derate Linearly at 8 mW/ $^\circ\text{C}$ to 300 mW
For $T_A = -55$ to $+100^\circ\text{C}$ (PACKAGE TYPE F, H)	500 mW
For $T_A = +100$ to $+125^\circ\text{C}$ (PACKAGE TYPE F, H)	Derate Linearly at 8 mW/ $^\circ\text{C}$ to 300 mW
For $T_A = -40$ to $+70^\circ\text{C}$ (PACKAGE TYPE M)	400 mW
For $T_A = +70$ to $+125^\circ\text{C}$ (PACKAGE TYPE M)	Derate Linearly at 6 mW/ $^\circ\text{C}$ to 70 mW
OPERATING-TEMPERATURE RANGE (T_A):	
PACKAGE TYPE F, H	-55 to $+125^\circ\text{C}$
PACKAGE TYPE E, M	-40 to $+125^\circ\text{C}$
STORAGE TEMPERATURE (T_{stg})	
	-65 to $+150^\circ\text{C}$
LEAD TEMPERATURE (DURING SOLDERING):	
At distance $1/16 \pm 1/32$ in. (1.59 ± 0.79 mm) from case for 10 s max.	$+265^\circ\text{C}$
Unit inserted into a PC Board (min. thickness $1/16$ in., 1.59 mm) with solder contacting lead tips only	$+300^\circ\text{C}$

- In certain applications, the external load-resistor current may include both V_{CC} and signal-line components. To avoid drawing V_{CC} current when switch current flows into the transmission gate inputs, the voltage drop across the bidirectional switch must not exceed 0.6 volt (calculated from R_{ON} values shown in Electrical Characteristics chart). No V_{CC} current will flow through R_L if the switch current flows into terminal 3 on the HC/HCT4351; terminals 3 and 13 on the HC/HCT4352; terminals 4, 14 and 15 on the HC/HCT4353.

RECOMMENDED OPERATING CONDITIONS:

For maximum reliability, nominal operating conditions should be selected so that operation is always within the following ranges:

CHARACTERISTIC	LIMITS		UNITS
	MIN.	MAX.	
Supply-Voltage Range (For $T_A =$ Full Package-Temperature Range) V_{CC} : *			
CD54/74HC Types	2	6	V
CD54/74HCT Types	4.5	5.5	V
Supply-Voltage Range (For $T_A =$ Full Package-Temperature Range) $V_{CC}-V_{EE}$			
CD54/74HC Types CD54/74HCT Types See Fig. 7	2	10	V
Supply-Voltage Range (For $T_A =$ Full Package-Temperature Range) V_{EE} : *			
CD54/74HC Types CD54/74HCT Types See Fig. 8	0	-6	V
DC Input Control Voltage, V_i	Gnd	V_{CC}	V
Analog Switch I/O Voltage, V_{IS}	V_{EE}	V_{CC}	V
Operating Temperature T_A :			
CD74 Types	-40	+125	$^\circ\text{C}$
CD54 Types	-55	+125	$^\circ\text{C}$
Input Rise and Fall Times, t_r , t_f			
at 2 V	0	1000	ns
at 4.5 V	0	500	ns
at 6 V	0	400	ns

* Unless otherwise specified, all voltages are referenced to Ground.

**CD54/74HC4351, CD54/74HCT4351
CD54/74HC4352, CD54/74HCT4352
CD54/74HC4353, CD54/74HCT4353**

RECOMMENDED OPERATING AREA AS A FUNCTION OF SUPPLY VOLTAGES

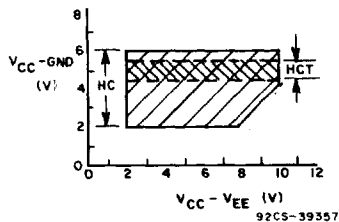

Fig. 7

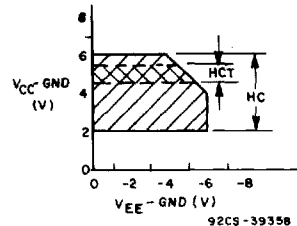

Fig. 8

STATIC ELECTRICAL CHARACTERISTICS

CHAR- ACTERISTIC	CD74HC/CD54HC4351, 4352, 4353												CD74HCT/CD54HCT4351, 4352, 4353												UNITS
	TEST CONDITIONS				74HC/54HC TYPES		74HC TYPES		54HC TYPES		TEST CONDITIONS				74HCT/54HCT TYPES		74HCT TYPES		54HCT TYPES						
	V _a	V _i	V _{EE}	V _{CC}	+25°C		-40/+85°C		-55/+125°C		V _a	V _i	V _{EE}	V _{CC}	+25°C		-40/+85°C		-55/+125°C						
	V	V	V	V	Min	Typ	Max	Min	Max	Min	Max	V	V	V	V	Min	Typ	Max	Min	Max	Min	Max			
High-Level Input Voltage V _{IH}				2	1.5	—	—	1.5	—	1.5	—			4.5	to	2	—	—	2	—	2	—	V		
				4.5	3.15	—	—	3.15	—	3.15	—			5.5											
				6	4.2	—	—	4.2	—	4.2	—														
Low-Level Input Voltage V _{IL}				2	—	—	0.5	—	0.5	—	0.5			4.5	to	—	—	0.8	—	0.8	—	0.8	V		
				4.5	—	—	1.35	—	1.35	—	1.35			5.5											
				6	—	—	1.8	—	1.8	—	1.8														
"On" Resistance R _{on}	V _{CC} or V _{EE}	V _{IL} or V _{IH}		0	4.5	—	70	160	—	200	—	240			0	4.5	—	70	160	—	200	—	240	Ω	
				0	6	—	60	140	—	175	—	210			—	—	—	—	—	—	—	—	—	Ω	
				-4.5	4.5	—	40	120	—	150	—	180			-4.5	4.5	—	40	120	—	150	—	180	Ω	
				0	4.5	—	90	180	—	225	—	270			0	4.5	—	90	180	—	225	—	270	Ω	
				0	6	—	80	160	—	200	—	240			—	—	—	—	—	—	—	—	—	Ω	
				-4.5	4.5	—	45	130	—	162	—	195			-4.5	4.5	—	45	130	—	162	—	195	Ω	
Maximum "On" Resistance between any two channels ΔR _{on}				0	4.5	—	10	—	—	—	—	—			0	4.5	—	10	—	—	—	—	—	Ω	
				0	6	—	8.5	—	—	—	—	—			—	—	—	—	—	—	—	—	—	Ω	
				-4.5	4.5	—	5	—	—	—	—	—			-4.5	4.5	—	5	—	—	—	—	—	Ω	
Switch On/Off Leakage Current I _z	For Switch OFF: When V _{is} =V _{CC} V _{os} =V _{EE} ; When V _{is} =V _{EE} , V _{os} =V _{CC} For Switch ON: All Applicable Combinations of V _{is} & V _{os} Voltage Levels	V _{IL} or V _{IH}		0	6	—	—	±0.1	—	±1	—	±1			0	6	—	—	±0.1	—	±1	—	±1	μA	
				-5	5	—	—	±0.1	—	±1	—	±1			-5	5	—	—	±0.1	—	±1	—	±1	μA	
				0	6	—	—	±0.1	—	±1	—	±1			0	6	—	—	±0.1	—	±1	—	±1	μA	
				-5	5	—	—	±0.2	—	±2	—	±2			-5	5	—	—	±0.2	—	±2	—	±2	μA	
				0	6	—	—	±0.2	—	±2	—	±2			0	6	—	—	±0.2	—	±2	—	±2	μA	
				-5	5	—	—	±0.4	—	±4	—	±4			-5	5	—	—	±0.4	—	±4	—	±4	μA	
Control Input Leakage Current I _{IL}	—	V _{CC} or Gnd		0	6	—	—	±0.1	—	±1	—	±1		**	5.5	—	—	±0.1	—	±1	—	±1	μA		
Quiescent Device Current I _{CC}	When V _{is} =V _{EE} , V _{os} =V _{CC} ; When V _{is} =V _{CC} , V _{os} =V _{EE}	V _{CC} or Gnd		0	6	—	—	8	—	80	—	160	Same as HC	Same as HC	0	5.5	—	—	8	—	80	—	160	μA	
				-5	5	—	—	16	—	160	—	320			-4.5	5.5	—	—	16	—	160	—	320	μA	
Additional Quiescent Device Current per input pin: 1 unit load ΔI _{CC} *													V _{CC} -2.1	4.5 to 5.5	—	100	360	—	450	—	490	—	μA		

* For dual-supply systems theoretical worst case (V_i = 2.4 V, V_{CC} = 5.5 V) specification is 1.8 mA.

** Any voltage between V_{CC} & Gnd.

CD54/74HC4351, CD54/74HCT4351
CD54/74HC4352, CD54/74HCT4352
CD54/74HC4353, CD54/74HCT4353

HCT INPUT LOADING TABLE

TYPE	INPUT	UNIT LOADS *
All	$\overline{E1}$, E2, S _n	0.5
(4351, 4352, 4353)	\overline{LE}	1.5

* Unit Load is ΔI_{CC} limit specified in Static Characteristics Chart, e.g., 360 μ A max. @ 25°C.

SWITCHING CHARACTERISTICS ($V_{CC} = 5$ V, $T_A = 25^\circ$ C, Input t_r , $t_f = 6$ ns)

CHARACTERISTIC	C _L pF	LIMITS						UNITS	
		4351		4352		4353			
		HC	HCT	HC	HCT	HC	HCT		
Turn "On" Time $\overline{E1}$, E2, or S _n to V _{OS}	t _{PZH} t _{PZL}	15	27	35	35	40	21	23	ns
Turn "Off" Time $\overline{E1}$, E2, or S _n to V _{OS}	t _{PHZ} t _{PLZ}		21	23	21	25	19	21	
Power Dissipation Capacitance *	C _{PD}	—	50	52	74	76	38	42	pF

* C_{PD} is used to determine the dynamic power consumption, per package.

$$P_D = C_{PD} V_{CC}^2 f_i + \Sigma (C_L + C_s) V_{CC}^2 f_o.$$

f_o = output frequency.

f_i = input frequency.

C_L = output load capacitance.

C_s = switch capacitance.

V_{CC} = supply voltage.

CD54/74HC4351, CD54/74HCT4351
CD54/74HC4352, CD54/74HCT4352
CD54/74HC4353, CD54/74HCT4353

SWITCHING CHARACTERISTICS (C_L = 50 pF, Input t_r, t_f = 6 ns)

CHARACTERISTIC	V _{EE}	V _{CC}	LIMITS												UNITS	
			+25°C				-40°C to +85°C				-55°C to +125°C					
			HC		HCT		74HC		74HCT		54HC		54HCT			
			MIN.	MAX.	MIN.	MAX.	MIN.	MAX.	MIN.	MAX.	MIN.	MAX.	MIN.	MAX.		
Propagation Delay	t _{PLH}	0	2	—	35	—	—	—	45	—	—	—	55	—	—	ns
Switch In to Out	t _{PHL}	0	4.5	—	7	—	7	—	9	—	9	—	11	—	11	
4351, 4352, 4353		0	6	—	6	—	—	—	8	—	—	—	9	—	—	
		-4.5	4.5	—	5	—	5	—	7	—	7	—	8	—	8	
Maximum Switch	t _{PZH}	0	2	—	300	—	—	—	375	—	—	—	450	—	—	
Turn "On" Delay	t _{PZL}	0	4.5	—	60	—	75	—	75	—	94	—	90	—	113	
4351		0	6	—	51	—	—	—	64	—	—	—	77	—	—	
$\overline{E1}, E2, \overline{LE}$ to V _{OS}		-4.5	4.5	—	55	—	60	—	69	—	75	—	83	—	90	
4351		0	2	—	300	—	—	—	375	—	—	—	450	—	—	
S _n to V _{OS}		0	4.5	—	60	—	75	—	75	—	94	—	90	—	113	
		0	6	—	51	—	—	—	64	—	—	—	77	—	—	
		-4.5	4.5	—	50	—	60	—	63	—	75	—	75	—	90	
4352		0	2	—	350	—	—	—	440	—	—	—	525	—	—	
$\overline{E1}, E2, \overline{LE}$ to V _{OS}		0	4.5	—	70	—	80	—	88	—	100	—	105	—	120	
		0	6	—	60	—	—	—	75	—	—	—	90	—	—	
		-4.5	4.5	—	60	—	65	—	75	—	81	—	90	—	98	
4352		0	2	—	375	—	—	—	470	—	—	—	565	—	—	
S _n to V _{OS}		0	4.5	—	75	—	80	—	94	—	100	—	113	—	120	
		0	6	—	64	—	—	—	80	—	—	—	96	—	—	
		-4.5	4.5	—	55	—	65	—	69	—	81	—	83	—	98	
4353		0	2	—	300	—	—	—	375	—	—	—	450	—	—	
$\overline{E1}, E2, \overline{LE}$ to V _{OS}		0	4.5	—	60	—	75	—	75	—	94	—	90	—	113	
		0	6	—	51	—	—	—	64	—	—	—	77	—	—	
		-4.5	4.5	—	55	—	60	—	69	—	75	—	83	—	90	
4353		0	2	—	300	—	—	—	375	—	—	—	450	—	—	
S _n to V _{OS}		0	4.5	—	60	—	75	—	75	—	94	—	90	—	113	
		0	6	—	58	—	—	—	69	—	—	—	77	—	—	
		-4.5	4.5	—	50	—	60	—	63	—	75	—	75	—	90	
Maximum Switch	t _{PHZ}	0	2	—	250	—	—	—	315	—	—	—	375	—	—	
Turn "Off" Delay	t _{PLZ}	0	4.5	—	50	—	55	—	63	—	69	—	75	—	83	
4351		0	6	—	43	—	—	—	54	—	—	—	64	—	—	
$\overline{E1}$ to V _{OS}		-4.5	4.5	—	40	—	40	—	50	—	50	—	60	—	60	
4351		0	2	—	250	—	—	—	315	—	—	—	375	—	—	
E2 to V _{OS}		0	4.5	—	50	—	60	—	63	—	75	—	75	—	90	
		0	6	—	43	—	—	—	54	—	—	—	64	—	—	
		-4.5	4.5	—	40	—	50	—	50	—	63	—	60	—	75	
4351		0	2	—	275	—	—	—	345	—	—	—	415	—	—	
\overline{LE} to V _{OS}		0	4.5	—	55	—	60	—	69	—	75	—	83	—	90	
		0	6	—	47	—	—	—	59	—	—	—	71	—	—	
		-4.5	4.5	—	45	—	55	—	56	—	69	—	68	—	83	

ns

CD54/74HC4351, CD54/74HCT4351

CD54/74HC4352, CD54/74HCT4352

CD54/74HC4353, CD54/74HCT4353

SWITCHING CHARACTERISTICS ($C_L = 50$ pF, Input $t_r, t_f = 6$ ns) (Continued)

CHARACTERISTIC	V_{EE}	V_{CC}	LIMITS												UNITS	
			+25°C				-40°C to +85°C				-55°C to +125°C					
			HC		HCT		74HC		74HCT		54HC		54HCT			
			MIN.	MAX.	MIN.	MAX.	MIN.	MAX.	MIN.	MAX.	MIN.	MAX.	MIN.	MAX.		
Maximum Switch	t_{PHZ}	0	2	—	275	—	—	—	345	—	—	—	415	—	—	ns
Turn "Off" Delay	t_{PLZ}	0	4.5	—	55	—	65	—	69	—	81	—	83	—	98	
4351		0	6	—	47	—	—	—	59	—	—	—	71	—	—	
S_n to V_{OS}		-4.5	4.5	—	48	—	55	—	60	—	69	—	71	—	83	
4352		0	2	—	275	—	—	—	345	—	—	—	415	—	—	
$\overline{E1}, E2, \overline{LE}$ to V_{OS}		0	4.5	—	55	—	60	—	69	—	75	—	83	—	90	
		0	6	—	47	—	—	—	59	—	—	—	71	—	—	
		-4.5	4.5	—	50	—	50	—	63	—	63	—	75	—	75	
4352		0	2	—	300	—	—	—	375	—	—	—	450	—	—	
S_n to V_{OS}		0	4.5	—	60	—	60	—	75	—	75	—	90	—	90	
		0	6	—	51	—	—	—	64	—	—	—	77	—	—	
		-4.5	4.5	—	50	—	50	—	63	—	63	—	75	—	75	
4353		0	2	—	275	—	—	—	345	—	—	—	415	—	—	
$\overline{E1}, E2, \overline{LE}$ to V_{OS}		0	4.5	—	55	—	60	—	69	—	75	—	83	—	90	
		0	6	—	47	—	—	—	59	—	—	—	71	—	—	
		-4.5	4.5	—	45	—	55	—	56	—	69	—	68	—	83	
4353		0	2	—	275	—	—	—	345	—	—	—	415	—	—	
S_n to V_{OS}		0	4.5	—	54	—	65	—	69	—	81	—	83	—	98	
		0	6	—	47	—	—	—	59	—	—	—	71	—	—	
		-4.5	4.5	—	45	—	55	—	56	—	69	—	68	—	83	
Setup Time		0	2	60	—	—	—	75	—	—	—	90	—	—	—	
4351 and 4353		0	4.5	12	—	12	—	15	—	15	—	18	—	18	—	
S_n to \overline{LE}		0	6	10	—	—	—	13	—	—	—	15	—	—	—	
		-4.5	4.5	18	—	14	—	23	—	18	—	27	—	21	—	
Hold Time		0	2	5	—	—	—	5	—	—	—	5	—	—	—	
All		0	4.5	5	—	5	—	5	—	5	—	5	—	5	—	
S_n to \overline{LE}		0	6	5	—	—	—	5	—	—	—	5	—	—	—	
		-4.5	4.5	5	—	5	—	5	—	5	—	5	—	5	—	
Pulse Width	t_w	0	2	100	—	—	—	125	—	—	—	150	—	—	—	
4351 and 4353		0	4.5	20	—	25	—	25	—	31	—	30	—	28	—	
\overline{LE}		0	6	17	—	—	—	21	—	—	—	26	—	—	—	
		-4.5	4.5	25	—	25	—	31	—	31	—	38	—	38	—	
4352		0	2	100	—	—	—	125	—	—	—	150	—	—	—	
\overline{LE}		0	4.5	20	—	20	—	25	—	25	—	30	—	30	—	
		0	6	17	—	—	—	21	—	—	—	26	—	—	—	
		-4.5	4.5	25	—	25	—	31	—	31	—	38	—	38	—	
Input (Control)	C_i	—	—	—	10	—	10	—	10	—	10	—	10	—	10	pF
Capacitance		—	—	—	10	—	10	—	10	—	10	—	10	—	10	pF
All		—	—	—	10	—	10	—	10	—	10	—	10	—	10	pF

CD54/74HC4351, CD54/74HCT4351
CD54/74HC4352, CD54/74HCT4352
CD54/74HC4353, CD54/74HCT4353

ANALOG CHANNEL CHARACTERISTICS - TYPICAL VALUES AT $T_A = 25^\circ\text{C}$

CHARACTERISTIC	TEST CONDITIONS	TYPES	LIMITS			UNITS
			V_{EE} (V)	V_{CC} (V)	HC/HCT	
Switch Input Capacitance C_i		All			5	pF
Common Capacitance C_{COM}		4351			25	
		4352			12	
		4353			8	
Minimum Switch Frequency Response @ -3 dB Figs. 14, 16, 18	See Fig. 9 Notes 1, 2	4351			145	MHz
		4352	-2.25	2.25	165	
		4353			200	
		4351			180	
		4352	-4.5	4.5	185	
		4353			>200	
Crosstalk Between Any Two Switches Note 4	See Fig. 10 Notes 2, 3	4351			N/A	dB
		4352	-2.25	2.25	(TBE)	
		4353			(TBE)	
		4351			N/A	
		4352	-4.5	4.5	(TBE)	
		4353			(TBE)	
Sine-Wave Distortion	See Fig. 11	All	-2.25	2.25	0.035	%
		All	-4.5	4.5	0.018	
\bar{E} or S to Switch Feedthrough Noise	See Fig. 12 Notes 2, 3	4351			(TBE)	mV
		4352	-2.25	2.25	(TBE)	
		4353			(TBE)	
		4351			(TBE)	
		4352	-4.5	4.5	(TBE)	
		4353			(TBE)	
Switch "OFF" Signal Feedthrough Figs. 15, 17, 19	See Fig. 13 Notes 2, 3	4351			-73	dB
		4352	-2.25	2.25	-65	
		4353			-64	
		4351			-75	
		4352	-4.5	4.5	-67	
		4353			-66	

Notes:

1. Adjust input voltage to obtain OdBm @ V_{OS} for $f_{in} = 1$ MHz.
2. V_{IS} is centered at $(V_{CC} - V_{EE})/2$.
3. Adjust input for OdBm.
4. Not applicable for HC/HCT4351.

CD54/74HC4351, CD54/74HCT4351
CD54/74HC4352, CD54/74HCT4352
CD54/74HC4353, CD54/74HCT4353
ANALOG TEST CIRCUITS

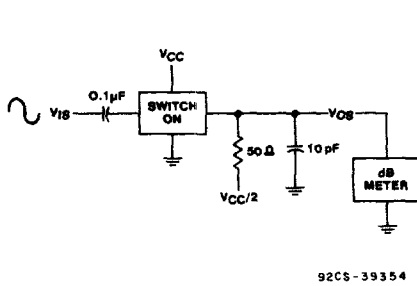

Fig. 9 - Frequency response test circuit.

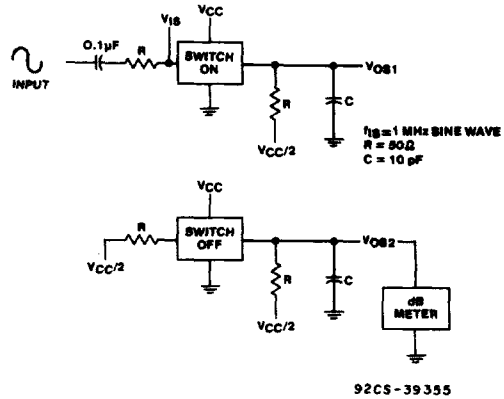

Fig. 10 - Crosstalk between two switches test circuit.

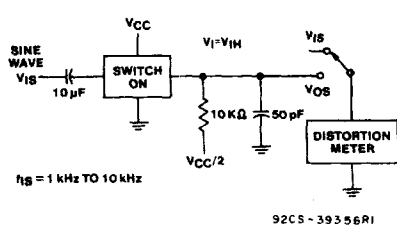

Fig. 11 - Sine wave distortion test circuit.

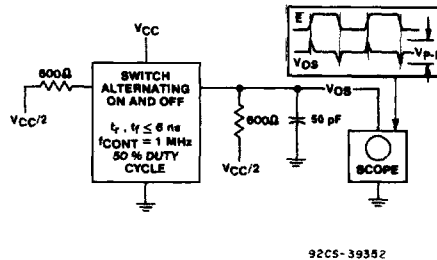

Fig. 12 - Control-to-switch feedthrough noise test circuit.

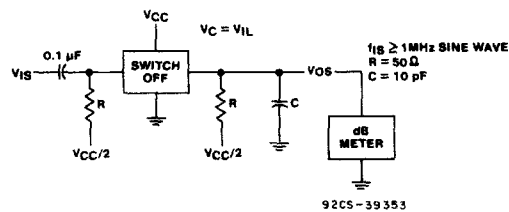

Fig. 13 - Switch off signal feedthrough.

**CD54/74HC4351, CD54/74HCT4351
CD54/74HC4352, CD54/74HCT4352
CD54/74HC4353, CD54/74HCT4353**

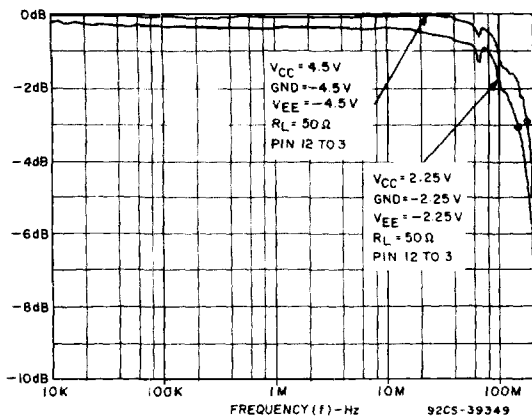

Fig. 14 - Channel on bandwidth (HC/HCT4351).

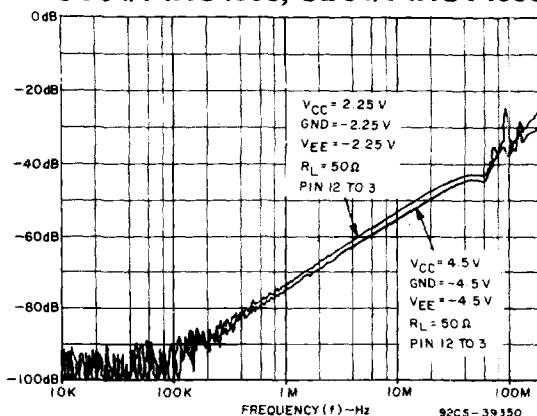

Fig. 15 - Channel off feedthrough (HC/HCT4351).

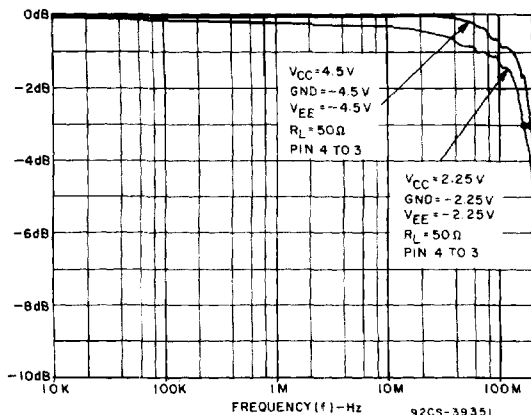

Fig. 16 - Channel on bandwidth (HC/HCT4352).

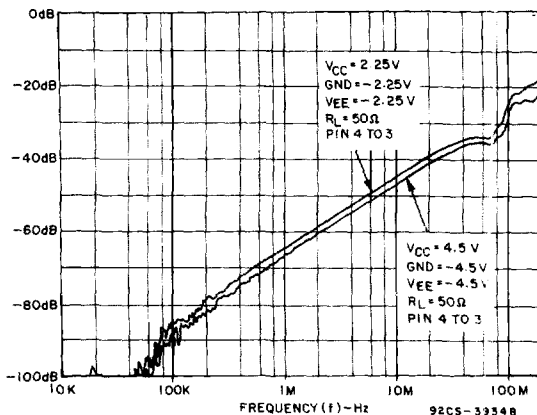

Fig. 17 - Channel off feedthrough (HC/HCT4352).

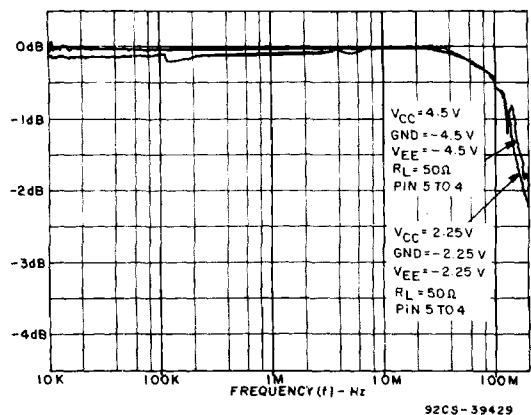

Fig. 18 - Channel on bandwidth (HC/HCT4353).

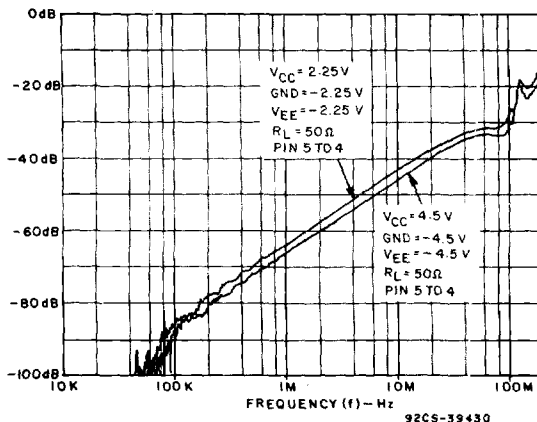

Fig. 19 - Channel off feedthrough (HC/HCT4353).

CD54/74HC4351, CD54/74HCT4351
CD54/74HC4352, CD54/74HCT4352
CD54/74HC4353, CD54/74HCT4353

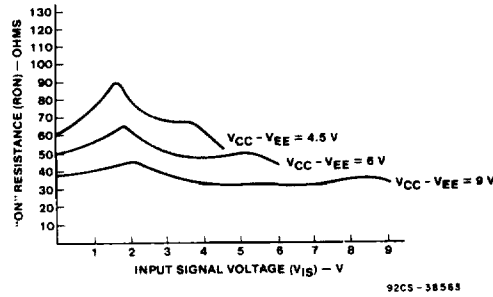
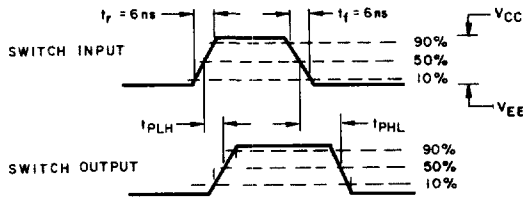
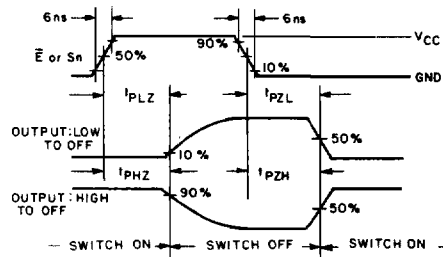

Fig. 20 - Typical ON resistance vs. input signal voltage.



92CS-36972R4



92CS-39359

HC4351, HC4352, HC4353

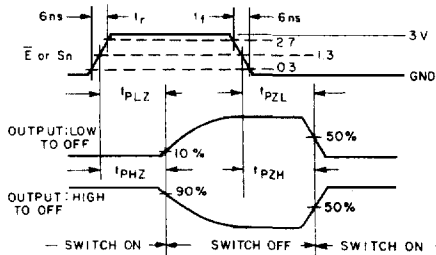

92CS-39360

Fig. 21 - Switch propagation delay, turn-on, turn-off times.

HCT4351, HCT4352, HCT4353

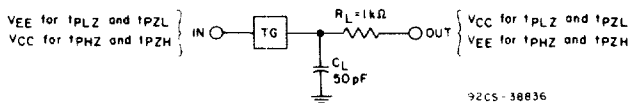

92CS-38836

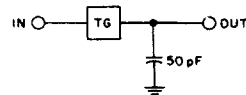

92CS-38835

Fig. 22 - Switch on/off propagation delay test circuit.

Fig. 23 - Switch In to Switch Out propagation delay test circuit.