maXTouch 336-node Touchscreen Controller

DATASHEET

Features

- Atmel® maXTouch® Adaptive Sensing Touchscreen Technology
 - Up to 24 X (transmit) lines and 14 Y (receive) lines
 - A maximum of 336 nodes can be allocated to the touchscreen
 - Screen sizes of 5.3 inches diagonal are supported (subject to configuration) while meeting Microsoft® Phone touch performance requirements
 - Larger screen sizes for Android applications supported (subject to configuration)
 - Multi-touch support with up to 10 concurrent touches tracked in real time
- Dual-boot OS support for Windows and Android
- Advanced Touch Handling
 - Moisture/Water Compensation
 - No false touch with condensation or water drop up to 22 mm diameter
 - One-finger tracking with condensation or water drop up to 22 mm diameter
 - Glove Support
 - Supports multiple-finger glove touch up to 1.5 mm thickness
 - Supports single-touch gloved operation with various materials up to 5 mm thickness
- Touch Performance
 - Mutual capacitance and self capacitance measurements supported for touch detection
 - Response Times
 - Initial latency <15 ms for first touch from idle, subject to configuration
 - Atmel maXCharger® technology to combat ambient, charger noise, and power-line noise:
 - Up to 240 Vpp between 1 Hz and 1 kHz sinusoidal waveform
 - Up to 20 Vpp between 1 kHz and 1 MHz sinusoidal waveform
 - Scan Speed
 - Typical report rate for 5 touches ≥ 100 Hz
- Enhanced Algorithms
 - Lens bending algorithms to remove signal distortions
 - Touch suppression algorithms to remove unintentional touches
 - Palm Recovery Algorithm for quick restoration to normal state
- Panel / Cover Glass Support
 - Supports fully-laminated sensors, touch-on-lens stack-ups and on-cell designs
 - Works with PET or glass, including curved profiles
 - Glass from 0.55 mm to 2.5 mm, dependent on screen size, touch size, and stack-up
 - Plastic from 0.2 mm to 1.2 mm, dependent on screen size and touch size
 - Works with all proprietary sensor patterns recommended by Atmel
 - Compatible with True Single-Layer designs

- Keys
 - Adjacent Key Suppression® (AKS®) technology is supported for false touch prevention
 - Up to 7 Peripheral Touch Controller (PTC) lines available for use as a grid of mutual capacitance keys
- Product Data Store Area
 - Up to 60 bytes of user-defined data can be stored during production
- Power Saving
 - Programmable timeout for automatic transition from active to idle states
 - Pipelined analog sensing detection and digital processing to optimize system power efficiency
- Application Interfaces
 - I²C-compatible slave mode: Standard/Fast mode 400 kHz, Fast-plus mode 1 MHz, High-speed mode up to 3.4 MHz
 - Interrupt to indicate when a message is available
- Power Supply
 - Digital (V_{dd}) 3.3 V nominal
 - Analog (AV_{dd}) 3.3 V nominal
 - Host interface I/O voltage (V_{ddIO}) 1.8 V to 3.3 V nominal
 - High voltage internal X line drive (XV_{dd}) = 2 × V_{dd} (6.6 V), with internal voltage doubler
- Packages
 - 56-pin UFQFN 6 × 6 × 0.6 mm, 0.35 mm pitch
 - 64-ball UFBGA 5 × 5 × 0.6 mm, 0.5 mm pitch
 - 72-ball UFBGA 6 × 6 × 0.6 mm, 0.5 mm pitch
- Environmental Conditions
 - Operating temperature –40°C to +85°C

Table of Contents

Features	1
Table of Contents	3
1. Overview of mXT336T	6
1.1 Introduction	6
2. Connection and Configuration Information	8
2.1 Pin Configuration – UFQFN 56 Pins	8
2.2 Pin Configuration – UFBGA 64 Balls	12
2.3 Pin Configuration – UFBGA 72 Balls	16
3. Schematics	20
3.1 56-pin UFQFN	20
3.2 64-ball UFBGA	21
3.3 72-ball UFBGA	22
3.4 Schematic Notes	23
4. Circuit Components	25
4.1 Decoupling Capacitors	25
4.2 I ² C Line Pull-up Resistors	25
4.3 Supply Quality	25
4.4 Suggested Voltage Regulators	25
5. Touchscreen Basics	27
5.1 Sensor Construction	27
5.2 Electrode Configuration	27
5.3 Scanning Sequence	27
5.4 Touchscreen Sensitivity	27
6. Sensor Layout	29
6.1 Mutual Capacitance Matrix	29
6.2 Peripheral Touch Controller Keys	29
7. Power-up / Reset Requirements	31
7.1 Power-up and Reset Sequence – VddIO Enabled after Vdd	32
8. Detailed Operation	34
8.1 Touch Detection	34
8.2 Operational Modes	34
8.3 Detection Integrator	34
8.4 Sensor Acquisition	34
8.5 Calibration	34
8.6 Digital Filtering and Noise Suppression	35
8.7 Shieldless Support and Display Noise Suppression	35
8.8 Retransmission Compensation	35
8.9 Grip Suppression	36
8.10 Lens Bending	36
8.11 Glove Detection	36
8.12 Unintentional Touch Suppression	36
8.13 GPIO Pins	36

9. I2C Communications	37
9.1 I2C Address	37
9.2 Writing To the Device	37
9.3 I ² C Writes in Checksum Mode	37
9.4 Reading From the Device	38
9.5 Reading Status Messages with DMA	38
9.6 $\overline{\text{CHG}}$ Line	40
9.7 SDA, SCL	41
9.8 Clock Stretching	42
10. PCB Design Considerations	43
10.1 Introduction	43
10.2 Printed Circuit Board	43
10.3 Supply Rails and Ground Tracking	43
10.4 Power Supply Decoupling	43
10.5 Single Supply Operation	44
10.6 Analog I/O	44
10.7 Component Placement and Tracking	44
10.8 EMC and Other Observations	45
11. Getting Started with mXT336T	46
11.1 Establishing Contact	46
11.2 Using the Object Protocol	46
11.3 Writing to the Device	49
11.4 Reading from the Device	49
12. Debugging and Tuning	50
12.1 Hardware SPI Debug Interface	50
12.2 Object-based Protocol	50
12.3 Self Test	50
13. Specifications	51
13.1 Absolute Maximum Specifications	51
13.2 Recommended Operating Conditions	51
13.3 DC Characteristics	52
13.4 Test Configuration	53
13.5 Current Consumption	55
13.6 Deep Sleep Current	57
13.7 Power Supply Ripple and Noise	58
13.8 Timing Specifications	59
13.9 Input/Output Characteristics	60
13.10 I2C Specifications	60
13.11 Touch Accuracy and Repeatability	61
13.12 Thermal Packaging	61
13.13 ESD Information	61
13.14 Soldering Profile	62
13.15 Moisture Sensitivity Level (MSL)	62
14. Package Information	63
14.1 Part Marking	63
14.2 Orderable Part Numbers	64
14.3 Mechanical Drawings	65

Associated Documents 68

Revision History 69

1. Overview of mXT336T

1.1 Introduction

The Atmel maXTouch family of touch controllers brings industry-leading capacitive touch performance to customer applications. The mXT336T features the latest generation of Atmel Adaptive Sensing technology that utilizes a hybrid mutual- and self-capacitive sensing system in order to deliver unparalleled touch features and a robust user experience.

- **Patented capacitive sensing method** – The mXT336T uses a unique charge-transfer acquisition engine to implement the Atmel-patented QMatrix[®] capacitive sensing method. Coupled with a state-of-the-art CPU, the entire touchscreen sensing solution can measure, classify and track number of individual finger touches with a high degree of accuracy in the shortest response time.
- **Capacitive Touch Engine (CTE)** – The mXT336T features an acquisition engine, which uses an optimal measurement approach to ensure almost complete immunity from parasitic capacitance on the receiver input lines. The engine includes sufficient dynamic range to cope with anticipated touchscreen self and mutual capacitances, which allows great flexibility for use with the Atmel proprietary sensor pattern designs. One- and two-layer ITO sensors are possible using glass or PET substrates.
- **Touch detection** – The mXT336T allows for both mutual- and self-capacitance measurements, with the self-capacitance measurements being used to augment the mutual-capacitance measurements to produce reliable touch information.

When self-capacitance measurements are enabled, touch classification is achieved using both mutual- and self-capacitance touch data. This has the advantage that both types of measurement systems can work together to detect touches under a wide variety of circumstances.

During idle mode, the device performs self-capacitance touch scans. When a touch is detected, the device starts performing mutual-capacitance touch scans as well as self capacitance scans.

Mutual-capacitance touch data is used wherever possible to classify touches as this has greater granularity than self-capacitance measurements and provides positional information on touches. For this reason, multiple touches can only be determined by mutual-capacitance touch data. If the self-capacitance touch processing detects multiple touches, touchscreen processing is skipped until mutual-capacitance touch data is available.

Self-capacitance measurements, on the other hand, allow for the detection of single touches in extreme case, such as single thick-glove touches, when touches can only be detected by self-capacitance data and may be missed by mutual-capacitance touch detection.

- **Display Noise Cancellation** – A combination of analog circuitry, hardware noise processing, and firmware that combats display noise without requiring additional listening channels or synchronization to display timing. This enables the use of shieldless touch sensor stacks, including touch-on-lens.
- **Noise filtering** – Hardware noise processing in the capacitive touch engine provides enhanced autonomous filtering and allows a broad range of noise profiles to be handled. The result is good performance in the presence of charger and LCD noise.
- **Processing power** – The main CPU has two powerful microsequencer coprocessors under its control consuming low power. This system allows the signal acquisition, preprocessing, postprocessing and housekeeping to be partitioned in an efficient and flexible way.
- **Interpreting user intention** – The Atmel hybrid mutual- and self-capacitance method provides unambiguous multitouch performance. Algorithms in the mXT336T provide optimized touchscreen position filtering for the smooth tracking of touches, responding to a user's intended touches while preventing false touch triggered by ambient noise or conductive material on the sensor surface, such as water. The suppression of unintentional touches from the user's gripping fingers, resting palm or touching cheek or ear also help ensure that the user's intentions are correctly interpreted.
- **Peripheral Touch Controller Keys** – The mXT336T supports up to 7 Peripheral Touch Controller (PTC) lines. These can be used as an array up to 9 mutual capacitance keys. The PTC lines are configured as X (drive) or Y (receive) lines as required, subject to configuration and performance considerations. See [Section 6.2 on page 29](#) for more information.

The benefits of the PTC keys include:

- Noise immunity through dedicated analog front-end
- Hardware noise filtering
- No external components required
- Guard channel capable

2. Connection and Configuration Information

2.1 Pin Configuration – UFQFN 56 Pins

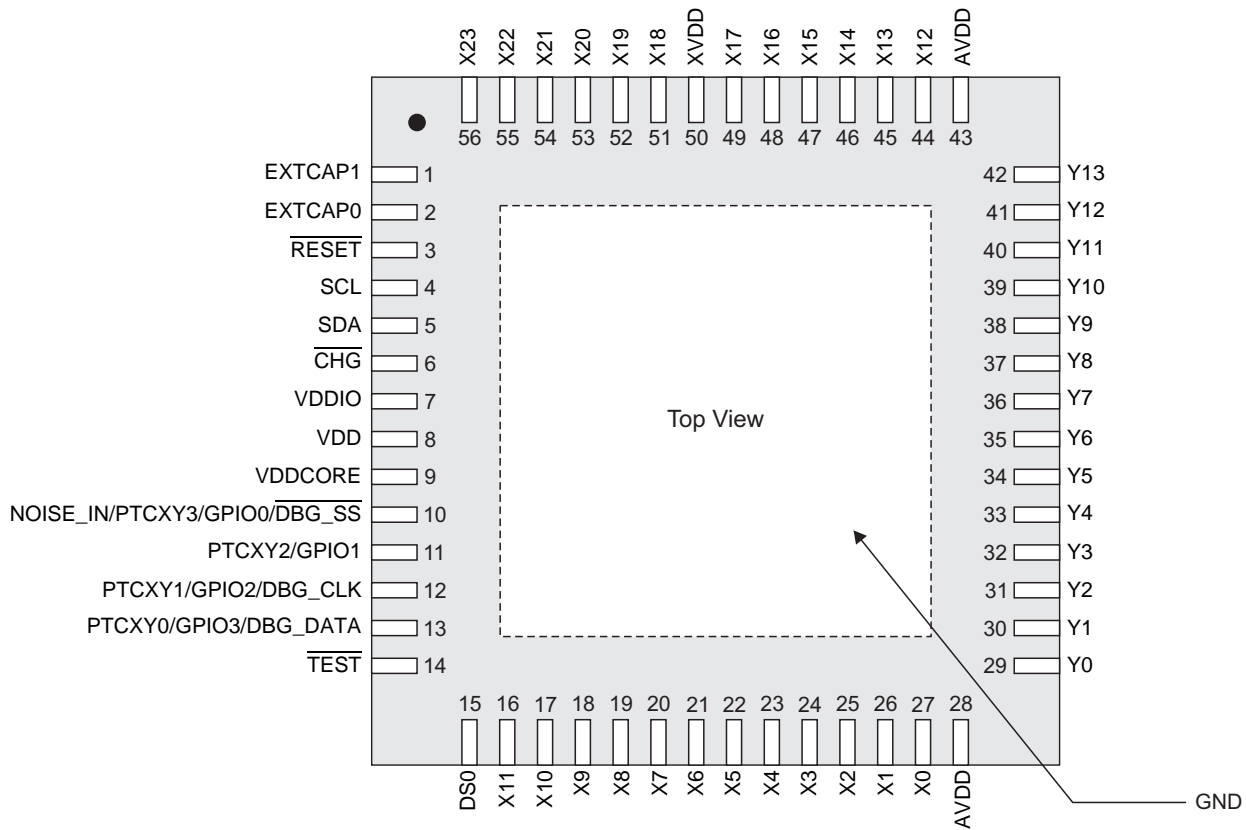

Table 2-1. Pin Listing – UFQFN 56 Pins

Pin	Name	Type	Description	If Unused...
1	EXTCAP1	P	Normal mode – leave open Voltage doubler mode – connect to EXTCAP0 via capacitor	Leave open
2	EXTCAP0	P	Normal mode – leave open Voltage doubler mode – connect to EXTCAP1 via capacitor	Leave open
3	$\overline{\text{RESET}}$	I	Reset low. Connection to host system is recommended	Pull up to VddIO
4	SCL	OD	Serial Interface clock	–
5	SDA	OD	Serial Interface Data	–
6	$\overline{\text{CHG}}$	OD	State change interrupt Note: Briefly set (~100 ms) as an input after power-up/reset for diagnostic purposes	Pull up to VddIO
7	VDDIO	P	Digital IO interface power	–
8	VDD	P	Digital power	–
9	VDDCORE	P	Digital core power	–
10	NOISE_IN PTCXY3 GPIO0 $\overline{\text{DBG_SS}}$	I/O	Noise present input Peripheral Touch Controller Channel General purpose I/O Debug SS line; pull up to VddIO	Input: GND Output: leave open
11	PTCXY2 GPIO1	I/O	Peripheral Touch Controller Channel General purpose I/O	Input: GND Output: leave open
12	PTCXY1 GPIO2 DBG_CLK	I/O	Peripheral Touch Controller Channel General purpose I/O Debug Clock	Input: GND Output: leave open
13	PTCXY0 GPIO3 DBG_DATA	I/O	Peripheral Touch Controller Channel General purpose I/O Debug Data	Input: GND Output: leave open
14	$\overline{\text{TEST}}$	–	Reserved for factory use. Pull up to VddIO	Pull up to VddIO
15	DS0	S	Driven Shield signal; used as guard track between X/Y signals and ground	Leave open
16	X11	S	X line connection	Leave open
17	X10	S	X line connection	Leave open
18	X9	S	X line connection	Leave open
19	X8	S	X line connection	Leave open
20	X7	S	X line connection	Leave open
21	X6	S	X line connection	Leave open
22	X5	S	X line connection	Leave open

Table 2-1. Pin Listing – UFQFN 56 Pins

Pin	Name	Type	Description	If Unused...
23	X4	S	X line connection	Leave open
24	X3	S	X line connection	Leave open
25	X2	S	X line connection	Leave open
26	X1	S	X line connection	Leave open
27	X0	S	X line connection	Leave open
28	AVDD	P	Analog power	–
29	Y0	S	Y line connection	Leave open
30	Y1	S	Y line connection	Leave open
31	Y2	S	Y line connection	Leave open
32	Y3	S	Y line connection	Leave open
33	Y4	S	Y line connection	Leave open
34	Y5	S	Y line connection	Leave open
35	Y6	S	Y line connection	Leave open
36	Y7	S	Y line connection	Leave open
37	Y8	S	Y line connection	Leave open
38	Y9	S	Y line connection	Leave open
39	Y10	S	Y line connection	Leave open
40	Y11	S	Y line connection	Leave open
41	Y12	S	Y line connection	Leave open
42	Y13	S	Y line connection	Leave open
43	AVDD	P	Analog power	–
44	X12	S	X line connection	Leave open
45	X13	S	X line connection	Leave open
46	X14	S	X line connection	Leave open
47	X15	S	X line connection	Leave open
48	X16	S	X line connection	Leave open
49	X17	S	X line connection	Leave open
50	XVDD	P	X line drive power	Leave open
51	X18	S	X line connection	Leave open
52	X19	S	X line connection	Leave open
53	X20	S	X line connection	Leave open
54	X21	S	X line connection	Leave open

Table 2-1. Pin Listing – UFQFN 56 Pins

Pin	Name	Type	Description	If Unused...
55	X22	S	X line connection	Leave open
56	X23	S	X line connection	Leave open
Pad	GND	P	Exposed pad must be connected to GND	–

Key:

I	Input only	O	Output only	I/O	Input or output
OD	Open drain output	P	Ground or power	S	Sense pin

2.2 Pin Configuration – UFBGA 64 Balls

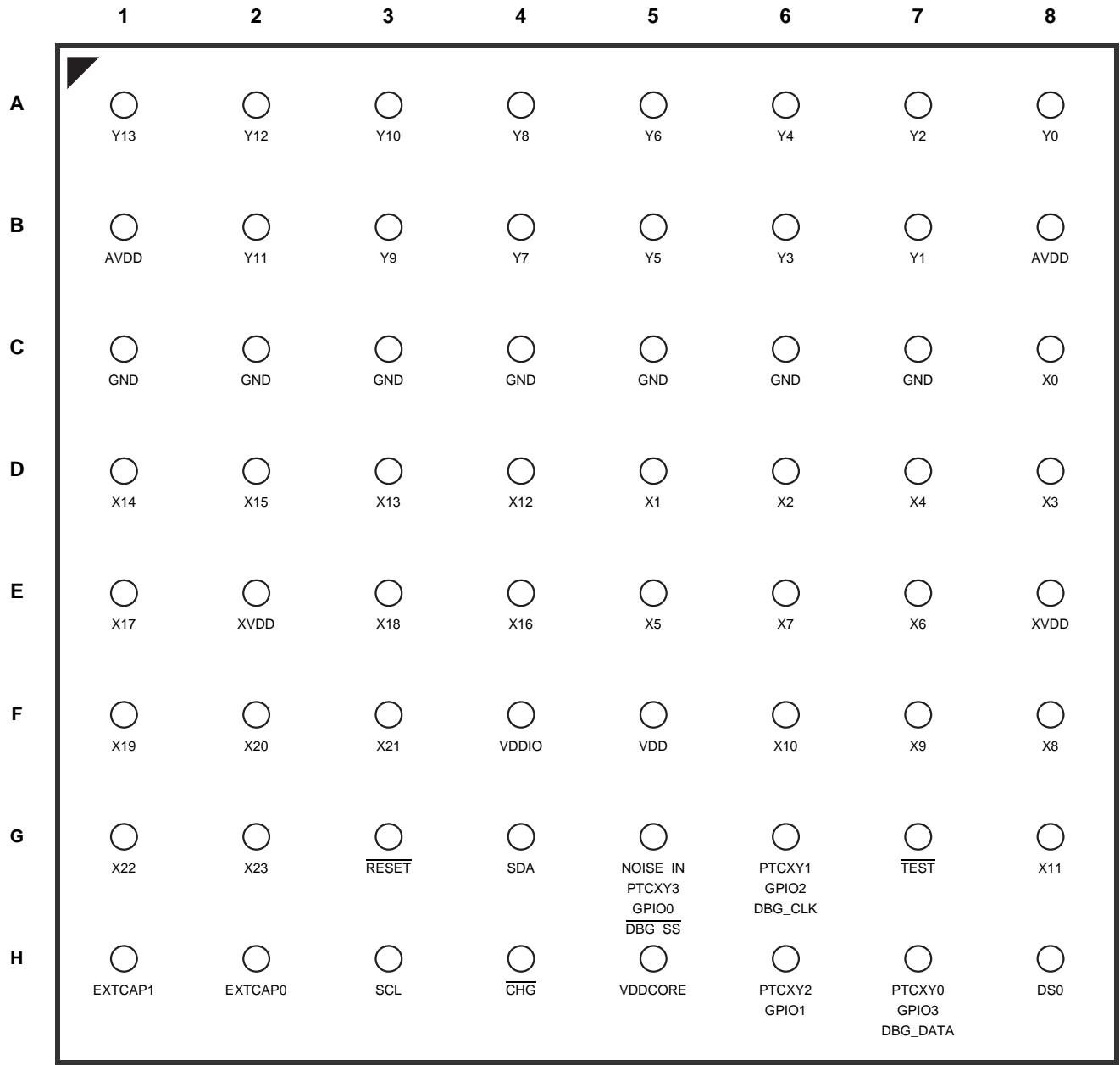

Top View

Table 2-2. Pin Listing – UFBGA 64 Balls

Pin	Name	Type	Description	If Unused...
A1	Y13	S	Y line connection	Leave open
A2	Y12	S	Y line connection	Leave open
A3	Y10	S	Y line connection	Leave open
A4	Y8	S	Y line connection	Leave open
A5	Y6	S	Y line connection	Leave open
A6	Y4	S	Y line connection	Leave open
A7	Y2	S	Y line connection	Leave open
A8	Y0	S	Y line connection	Leave open
B1	AVDD	P	Analog power	–
B2	Y11	S	Y line connection	Leave open
B3	Y9	S	Y line connection	Leave open
B4	Y7	S	Y line connection	Leave open
B5	Y5	S	Y line connection	Leave open
B6	Y3	S	Y line connection	Leave open
B7	Y1	S	Y line connection	Leave open
B8	AVDD	P	Analog power	–
C1	GND	P	Ground	–
C2	GND	P	Ground	–
C3	GND	P	Ground	–
C4	GND	P	Ground	–
C5	GND	P	Ground	–
C6	GND	P	Ground	–
C7	GND	P	Ground	–
C8	X0	S	X line connection	Leave open
D1	X14	S	X line connection	Leave open
D2	X15	S	X line connection	Leave open
D3	X13	S	X line connection	Leave open
D4	X12	S	X line connection	Leave open
D5	X1	S	X line connection	Leave open
D6	X2	S	X line connection	Leave open
D7	X4	S	X line connection	Leave open
D8	X3	S	X line connection	Leave open

Table 2-2. Pin Listing – UFBGA 64 Balls

Pin	Name	Type	Description	If Unused...
E1	X17	S	X line connection	Leave open
E2	XVDD	P	X line drive power	Leave open
E3	X18	S	X line connection	Leave open
E4	X16	S	X line connection	Leave open
E5	X5	S	X line connection	Leave open
E6	X7	S	X line connection	Leave open
E7	X6	S	X line connection	Leave open
E8	XVDD	P	X line drive power	Leave open
F1	X19	S	X line connection	Leave open
F2	X20	S	X line connection	Leave open
F3	X21	S	X line connection	Leave open
F4	VDDIO	P	Digital IO interface power	–
F5	VDD	P	Digital power	–
F6	X10	S	X line connection	Leave open
F7	X9	S	X line connection	Leave open
F8	X8	S	X line connection	Leave open
G1	X22	S	X line connection	Leave open
G2	X23	S	X line connection	Leave open
G3	$\overline{\text{RESET}}$	I	Reset low. Connection to host system is recommended	Pull up to VddIO
G4	SDA	OD	Serial Interface Data	–
G5	NOISE_IN PTCXY3 GPIO0 $\overline{\text{DBG_SS}}$	I/O	Noise present input Peripheral Touch Controller Channel General purpose I/O Debug SS line; pull up to VddIO	Input: GND Output: leave open
G6	PTCXY1 GPIO2 DBG_CLK	I/O	Peripheral Touch Controller Channel General purpose I/O Debug Clock	Input: GND Output: leave open
G7	$\overline{\text{TEST}}$	–	Reserved for factory use. Pull up to VddIO	Pull up to VddIO
G8	X11	S	X line connection	Leave open
H1	EXTCAP1	P	Connect to EXTCAP0 via capacitor; see schematic notes	Leave open
H2	EXTCAP0	P	Connect to EXTCAP1 via capacitor; see schematic notes	Leave open
H3	SCL	OD	Serial Interface Clock	–

Table 2-2. Pin Listing – UFBGA 64 Balls

Pin	Name	Type	Description	If Unused...
H4	$\overline{\text{CHG}}$	OD	State change interrupt Note: Briefly set (~100 ms) as an input after power-up/reset for diagnostic purposes	Pull up to VddIO
H5	VDDCORE	P	Digital core power	–
H6	PTCXY2 GPIO1	I/O	Peripheral Touch Controller Channel General purpose I/O	Input: GND Output: leave open
H7	PTCXY0 GPIO3 DBG_DATA	I/O	Peripheral Touch Controller Channel General purpose I/O Debug Data	Input: GND Output: leave open
H8	DS0	S	Driven Shield signal; used as guard track between X/Y signals and ground	Leave open

Key:

I	Input only	O	Output only	I/O	Input or output
OD	Open drain output	P	Ground or power	S	Sense pin

2.3 Pin Configuration – UFBGA 72 Balls

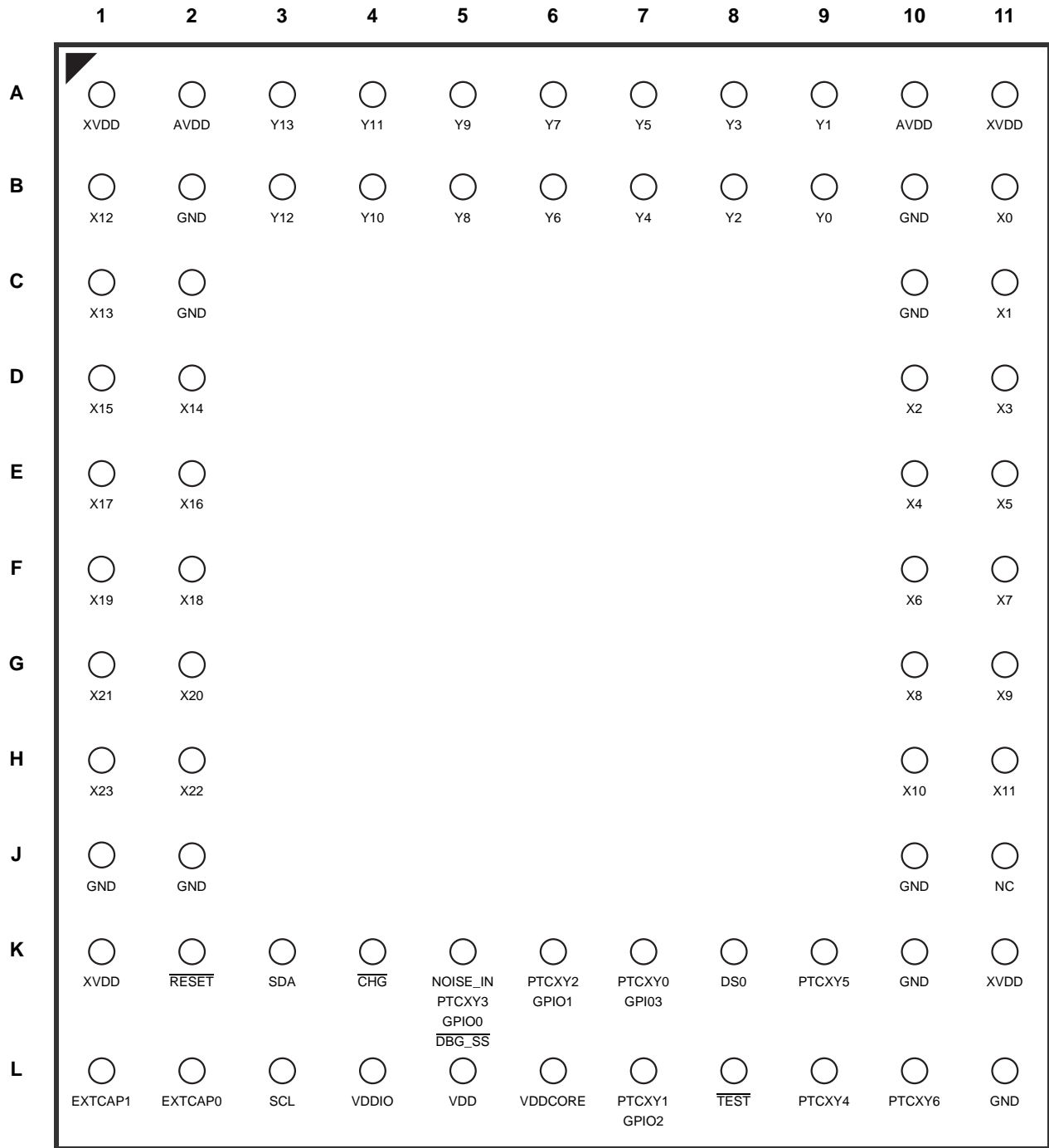

Top View

Table 2-3. Pin Listing – UFBGA 72 Balls

Pin	Name	Type	Description	If Unused...
A1	XVDD	P	X line drive power	Leave open
A2	AVDD	P	Analog power	–
A3	Y13	S	Y line connection	Leave open
A4	Y11	S	Y line connection	Leave open
A5	Y9	S	Y line connection	Leave open
A6	Y7	S	Y line connection	Leave open
A7	Y5	S	Y line connection	Leave open
A8	Y3	S	Y line connection	Leave open
A9	Y1	S	Y line connection	Leave open
A10	AVDD	P	Analog power	–
A11	XVDD	P	X line drive power	Leave open
B1	X12	S	X line connection	Leave open
B2	GND	P	Ground	–
B3	Y12	S	Y line connection	Leave open
B4	Y10	S	Y line connection	Leave open
B5	Y8	S	Y line connection	Leave open
B6	Y6	S	Y line connection	Leave open
B7	Y4	S	Y line connection	Leave open
B8	Y2	S	Y line connection	Leave open
B9	Y0	S	Y line connection	Leave open
B10	GND	P	Ground	–
B11	X0	S	X line connection	Leave open
C1	X13	S	X line connection	Leave open
C2	GND	P	Ground	–
...				
C10	GND	P	Ground	–
C11	X1	S	X line connection	Leave open
D1	X15	S	X line connection	Leave open
D2	X14	S	X line connection	Leave open
...				
D10	X2	S	X line connection	Leave open
D11	X3	S	X line connection	Leave open

Table 2-3. Pin Listing – UFBGA 72 Balls (Continued)

Pin	Name	Type	Description	If Unused...
E1	X17	S	X line connection	Leave open
E2	X16	S	X line connection	Leave open
...				
E10	X4	S	X line connection	Leave open
E11	X5	S	X line connection	Leave open
F1	X19	S	X line connection	Leave open
F2	X18	S	X line connection	Leave open
...				
F10	X6	S	X line connection	Leave open
F11	X7	S	X line connection	Leave open
G1	X21	S	X line connection	Leave open
G2	X20	S	X line connection	Leave open
...				
G10	X8	S	X line connection	Leave open
G11	X9	S	X line connection	Leave open
H1	X23	S	X line connection	Leave open
H2	X22	S	X line connection	Leave open
...				
H10	X10	S	X line connection	Leave open
H11	X11	S	X line connection	Leave open
J1	GND	P	Ground	–
J2	GND	P	Ground	–
...				
J10	GND	P	Ground	–
J11	NC	I/O	No Connection	–
K1	XVDD	P	X line drive power	Leave open
K2	$\overline{\text{RESET}}$	I	Reset low. Connection to host system is recommended	Pull up to VddIO
K3	SDA	OD	Serial Interface Data	–
K4	$\overline{\text{CHG}}$	OD	State change interrupt Note: Briefly set (~100 ms) as an input after power-up/reset for diagnostic purposes	Pull up to VddIO

Table 2-3. Pin Listing – UFBGA 72 Balls (Continued)

Pin	Name	Type	Description	If Unused...
K5	NOISE_IN PTCXY3 GPIO0 $\overline{\text{DBG_SS}}$	I/O	Noise present input Peripheral Touch Controller Channel General purpose I/O Debug SS line; pull up to VddIO	Input: GND Output: leave open
K6	PTCXY2 GPIO1	I/O	Peripheral Touch Controller Channel General purpose I/O	Input: GND Output: leave open
K7	PTCXY0 GPIO3	I/O	Peripheral Touch Controller Channel General purpose I/O	Leave open
K8	DS0	O	Driven Shield signal; used as guard track between X/Y signals and ground	Leave open
K9	PTCXY5	I/O	Peripheral Touch Controller Channel	Leave open
K10	GND	P	Ground	–
K11	XVDD	P	X line drive power	Leave open
L1	EXTCAP1	P	Normal mode – leave open Voltage doubler mode – connect to EXTCAP0 via capacitor	Leave open
L2	EXTCAP0	P	Normal mode – leave open Voltage doubler mode – connect to EXTCAP1 via capacitor	Leave open
L3	SCL	OD	Serial Interface clock	–
L4	VDDIO	P	Digital IO interface power	–
L5	VDD	P	Digital power	–
L6	VDDCORE	P	Digital core power	–
L7	PTCXY1 GPIO2	I/O	Peripheral Touch Controller Channel General purpose I/O	Input: GND Output: leave open
L8	$\overline{\text{TEST}}$	–	Reserved for factory use. Pull up to VddIO	Pull up to VddIO
L9	PTCXY4	I/O	Peripheral Touch Controller Channel	Leave open
L10	PTCXY6	I/O	Peripheral Touch Controller Channel	Leave open
L11	GND	P	Ground	–

Key:

I	Input only	O	Output only	I/O	Input or output
OD	Open drain output	P	Ground or power	S	Sense pin

3. Schematics

3.1 56-pin UFQFN

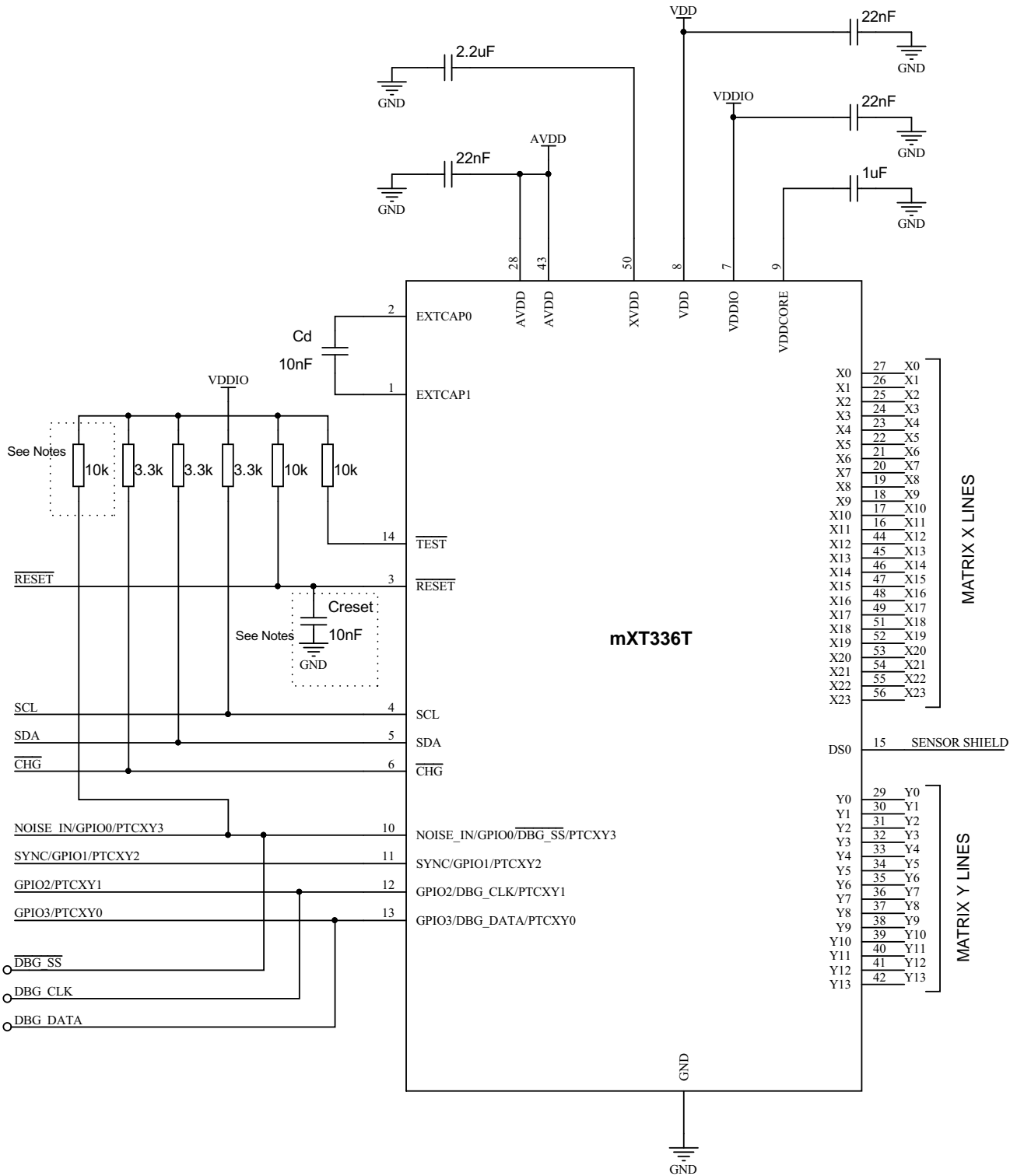

See Section 3.4 "Schematic Notes" on page 23.

3.2 64-ball UFBGA

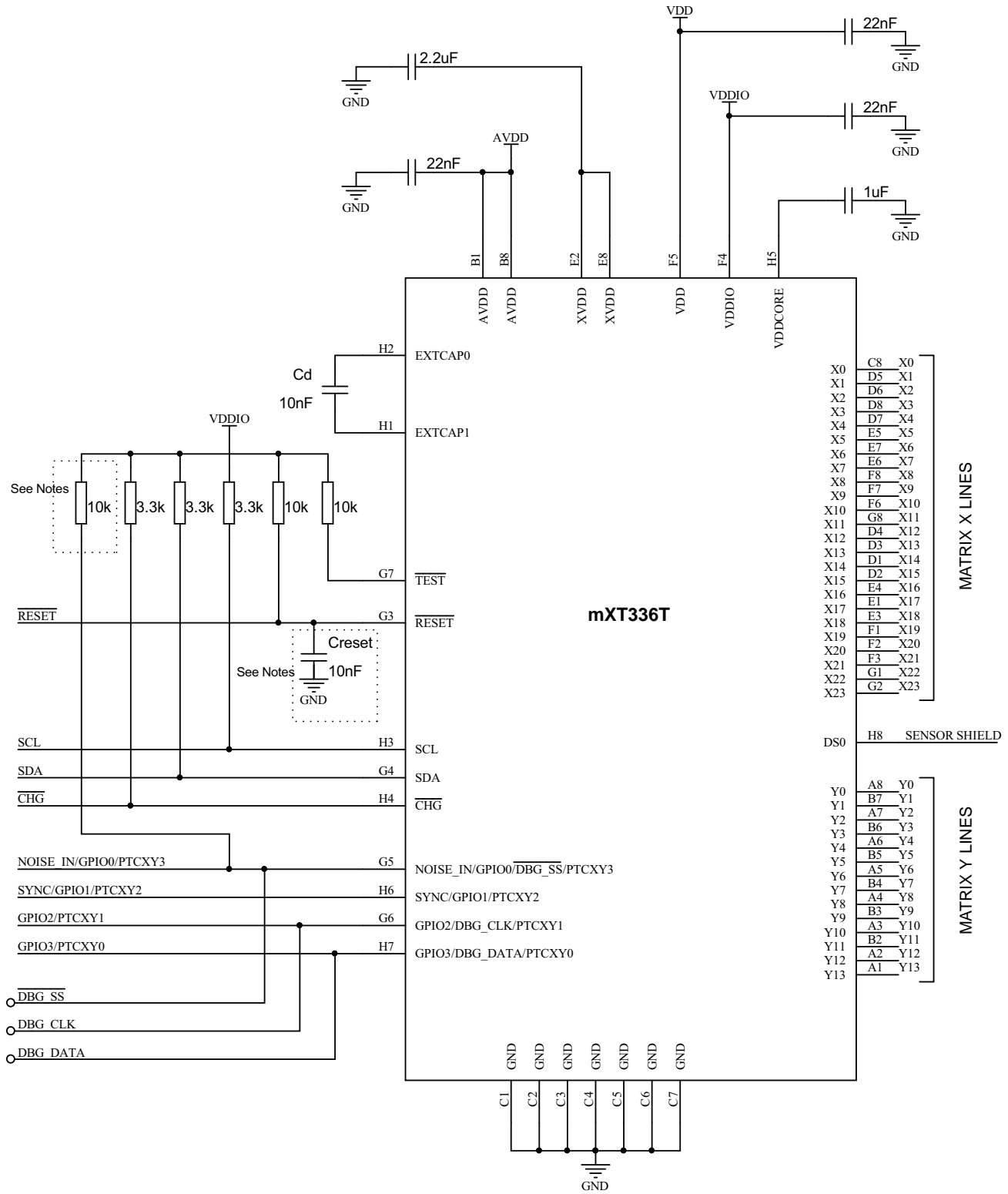

See Section 3.4 "Schematic Notes" on page 23

3.3 72-ball UFBGA

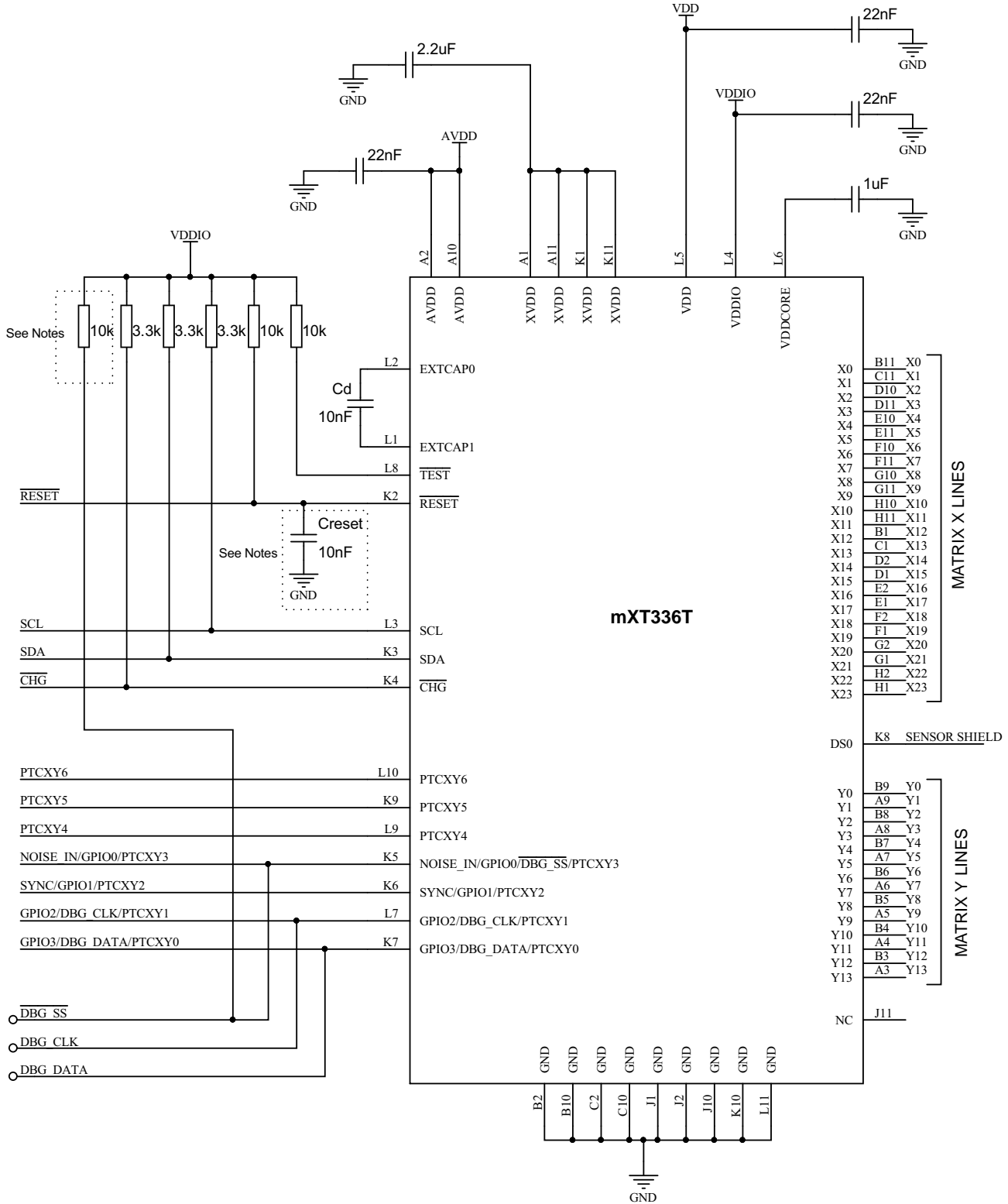

See Section 3.4 "Schematic Notes" on page 23

3.4 Schematic Notes

3.4.1 Decoupling capacitors:

1. Decoupling capacitors must be X7R or X5R and placed <5 mm away from the pins for which they act as decoupling capacitors.
2. The schematics show the minimum capacitors required. If the ball configuration means that sharing a decoupling capacitor is not possible, then the number of capacitors should be increased.
3. If the device is placed on the system board, the minimum number of capacitors required is as shown in the schematics on [page 21](#) and [page 22](#). Note that this requires that the voltage regulator supplies for Avdd/Vdd and VddIO are clean and noise free. It also assumes that the track length between the capacitors and on-board power supplies is < 50 mm.
4. If an active tail design is used, the voltage regulators are likely to be some distance from the device and it may be necessary to implement additional decoupling. In this case, a parallel combination of capacitors is recommended to give high and low frequency filtering, as shown in [Figure 3-1](#).

Figure 3-1. Additional Recommended Decoupling Capacitors

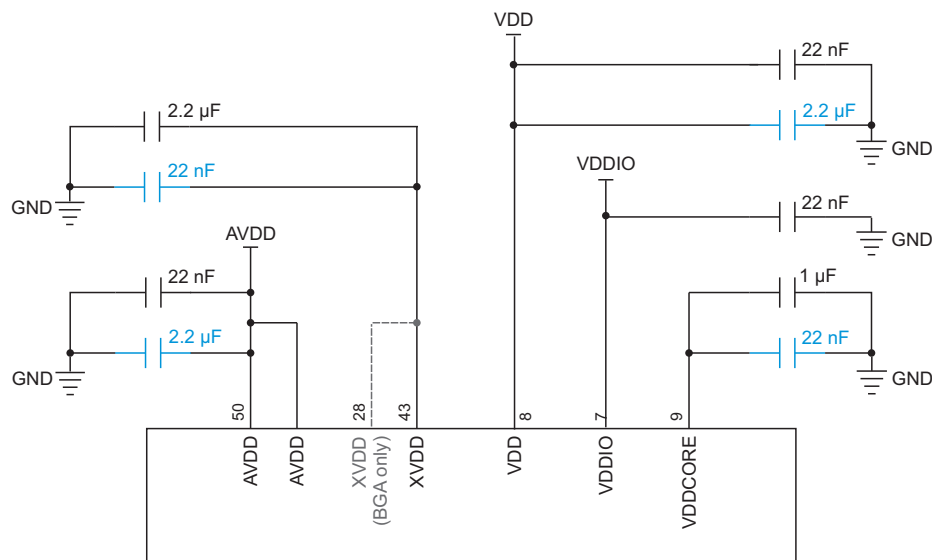

NOTE: Recommended additional decoupling capacitors are shown in blue

3.4.2 VDDCORE

VDDCore is internally generated from the Vdd 3.3 V power supply. To guarantee stability of the internal voltage regulator, a minimum value of 1 μF must be used for decoupling on VDDCORE.

3.4.3 DBG_SS Line

The DBG_SS line shares the same pin as GPIO0. The GPIO function cannot be used when the SPI Debug port is in use. See [Section 12. on page 50](#) for further information. A similar restriction applies to DBG_CLK and DBG_DATA.

The pull-up resistor in the schematics is optional and should be present only if the ball/pin is used as DBG_SS. For more information refer to Application Note: *QTAN0050 Using the maXTouch Debug Port*.

3.4.4 RESET Line

The RESET line is shown on the schematics with a 10 nF capacitor (Creset) to ground. This capacitor is optional but may help if ESD issues are encountered.

3.4.5 Voltage Doubler

To use XVdd voltage doubler:

- EXTCAP0 must be connected to EXTCAP1 via a capacitor (C_d) to provide XVdd voltage doubler mode.
- The recommended value of the capacitor is 10 nF. Other values can be used if necessary after consultation with Atmel.
- The capacitor on XVDD should be rated at least 10 V if the voltage doubler is used.

If XVdd voltage doubler is not required:

- Capacitor C_d must be omitted and EXTCAP0 and EXTCAP1 left unconnected.
- XVDD line(s) must be connected to VDD.

These modifications are shown in [Figure 3-2](#).

Figure 3-2. No voltage Doubler

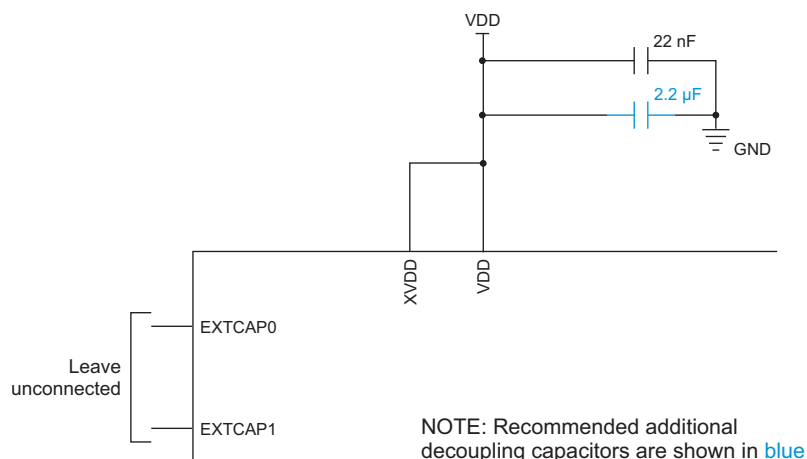

3.4.6 Low Drop-Out Voltage Regulators (LDOs)

In applications where the VddIO supply is at the same voltage level as Vdd and AVdd (that is, 3.3 V) it is permissible to use a single LDO for all supply rails (AVDD/VDD/VDDIO). A suitable circuit is shown in [Figure 3-3](#).

Figure 3-3. Low Drop-Out Regulators

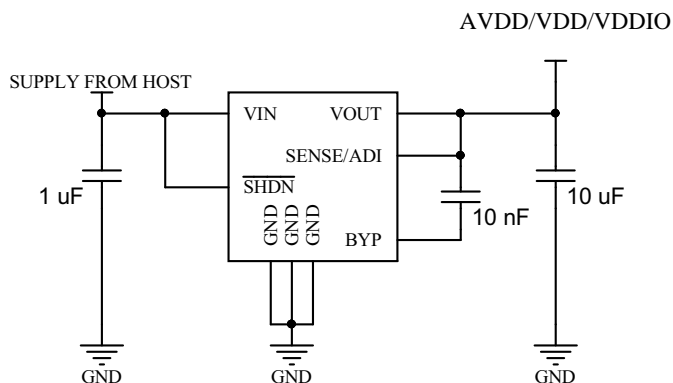

Where poor or inadequate tracking or decoupling leads to high noise levels on the supply rails, Atmel recommends that a separate low drop-out voltage regulator supply is used for the AVdd supply.

See [Section 4.4 on page 25](#) for further details. A list of approved regulators is given in [Table 4-1 on page 26](#).

4. Circuit Components

4.1 Decoupling Capacitors

Each power supply pin requires decoupling as described in [Section 3.4 on page 23](#). The capacitors should be ceramic X7R or X5R.

The PCB traces connecting the decoupling capacitors to the pins of the device must not exceed 10 mm in length. This limits any stray inductance that would reduce filtering effectiveness.

4.2 I²C Line Pull-up Resistors

The values for pull-up resistors on SDA and SCL need to be chosen to ensure rise times are within I²C specification – if the rise time is too long the overall clock rate will be reduced.

If using a VddIO at the low end of the allowable range it is likely that the pull-up resistor values will need to be reduced from those shown on the schematic.

4.3 Supply Quality

While the device has good Power Supply Rejection Ratio properties, poorly regulated and/or noisy power supplies can significantly reduce performance.

Always operate the device with a well-regulated and clean AVdd supply. It supplies the sensitive analog stages in the device.

4.4 Suggested Voltage Regulators

An LDO regulator should be chosen that provides adequate output capability, low noise, good load regulation and step response.

Suitable fixed output LDO devices are shown in [Table 4-1 on page 26](#).

With a single regulator, PCB layout is more critical than with multiple LDO regulators, and special care with the PCB layout should be taken. See [Section 10.5 on page 44](#) for information concerning PCB design with a single LDO.

4.4.1 Multiple Voltage Regulator Supply

The AVdd supply stability is critical for the device because this supply interacts directly with the analog front end. If noise problems exist when using a single LDO regulator, Atmel recommends that the supply for the analog section of the board be supplied by a regulator that is separate from the logic supply. This reduces the amount of noise injected into the sensitive, low signal level parts of the design.

4.4.2 Suggested Voltage Regulators

The voltage regulators listed in [Table 4-1](#) have been tested and found to work well with the mXT336T.

Table 4-1. Suitable LDO Regulators

Manufacturer	Device	Current Rating (mA)
Analog Devices	ADP122/ADP123	300
Diodes Inc.	AP2125	300
Diodes Inc.	AP7335	300
Linear Technology	LT1763CS8-3.3	500
NXP	LD6836	300
Texas Instruments	LP2981	100
Texas Instruments	LP3981	300
Texas Instruments	LP5996	150 / 300

1. Some manufacturers claim that minimal or no capacitance is required for correct regulator operation. However, in all cases, a minimum of a 1.0 μF ceramic, low ESR capacitor at the input and output of these devices should be used. The manufacturer's datasheets should always be referred to when selecting capacitors for these devices and the typical recommended values, types and dielectrics adhered to.

4.4.3 LDO Selection Criteria

The LDO devices in [Table 4-1](#) have been proved to provide satisfactory performance in Atmel maxTouch controllers, however, if it is desired to use an alternative LDO, certain performance criteria should be verified before using the device. These are:

- Stable with low value multi-layer ceramic capacitors on input and output – actual values will be device dependent, but it is good design practice to use values greater than the minimum specified in the LDO regulator data sheet
- Low output noise – less than 100 μV RMS over the range 10 Hz to 1 MHz
- Good load transient response – this should be less than 35 mV peak when a load step change of 100 mA is applied at the device output terminal
- Input supply requirement of between 4.5 V and 5.5 V
- Low quiescent current to improve battery life
- Thermal and current limit overload protection
- Ideally, select an LDO with common footprint, to allow interchanging between regulators

5. Touchscreen Basics

5.1 Sensor Construction

A touchscreen is usually constructed from a number of transparent electrodes. These are typically on a glass or plastic substrate. They can also be made using non-transparent electrodes, such as copper or carbon. Electrodes are constructed from Indium Tin Oxide (ITO) or metal mesh. Thicker electrodes yield lower levels of resistance (perhaps tens to hundreds of Ω /square) at the expense of reduced optical clarity. Lower levels of resistance are generally more compatible with capacitive sensing. Thinner electrodes lead to higher levels of resistance (perhaps hundreds to thousands of Ω /square) with some of the best optical characteristics.

Interconnecting tracks can cause problems. The excessive RC time constants formed between the resistance of the track and the capacitance of the electrode to ground can inhibit the capacitive sensing function. In such cases, the tracks should be replaced by screen printed conductive inks (non-transparent) outside the touchscreen viewing area.

5.2 Electrode Configuration

The specific electrode designs used in Atmel touchscreens are the subject of various patents and patent applications. Further information is available on request.

The device supports various configurations of electrodes as summarized in [Section 6. on page 29](#).

5.3 Scanning Sequence

All nodes are scanned in sequence by the device. There is a full parallelism in the scanning sequence to improve overall response time. The nodes are scanned by measuring capacitive changes at the intersections formed between the first X line and all the Y lines. Then the intersections between the next X line and all the Y lines are scanned, and so on, until all X and Y combinations have been measured.

The device can be configured in various ways. It is possible to disable some nodes so that they are not scanned at all. This can be used to improve overall scanning time.

5.4 Touchscreen Sensitivity

5.4.1 Adjustment

Sensitivity of touchscreens can vary across the extents of the electrode pattern due to natural differences in the parasitic capacitance of the interconnections, control chip, and so on. An important factor in the uniformity of sensitivity is the electrode design itself. It is a natural consequence of a touchscreen pattern that the edges form a discontinuity and hence tend to have a different sensitivity. The electrodes at the far edges do not have a neighboring electrode on one side and this affects the electric field distribution in that region.

A sensitivity adjustment is available for the whole touchscreen. This adjustment is a basic algorithmic threshold that defines when a node is considered to have enough signal change to qualify as being in detect.

5.4.2 Mechanical Stackup

The mechanical stackup refers to the arrangement of material layers that exist above and below a touchscreen. The arrangement of the touchscreen in relation to other parts of the mechanical stackup has an effect on the overall sensitivity of the screen. QMatrix technology has an excellent ability to operate in the presence of ground planes close to the sensor. QMatrix sensitivity is attributed more to the interaction of the electric fields between the transmitting (X) and receiving (Y) electrodes than to the surface area of these electrodes. For this reason, stray capacitance on the X or Y electrodes does not strongly reduce sensitivity.

Front panel dielectric material has a direct bearing on sensitivity. Plastic front panels are usually suitable up to about 1.2 mm, and glass up to about 2.5 mm (dependent upon the screen size and layout). The thicker the front panel, the lower the signal-to-noise ratio of the measured capacitive changes and hence the lower the resolution of the touchscreen. In general, glass front panels are near optimal because they conduct electric fields almost twice as easily as plastic panels.

Note: Care should be taken using ultra-thin glass panels as retransmission effects can occur, which can significantly degrade performance.

6. Sensor Layout

6.1 Mutual Capacitance Matrix

The specific electrode designs used in Atmel touchscreens are the subject of various patents and patent applications. Further information is available on request.

The physical matrix can be configured to have one or more touch objects. These are configured using the appropriate touch objects (Multiple Touch Touchscreen T100). It is not mandatory to have all the allowable touch objects present. The objects are disabled by default so only those that you wish to use need to be enabled. Refer to the *mXT336T 2.3 Protocol Guide* for more information on configuring the touch objects.

The device supports various configurations of electrodes as summarized below:

- Touchscreen: 24 X x 14 Y maximum (subject to other configurations)

When designing the physical layout of the touch panel, obey the following rules:

- Each touch object should be a regular rectangular shape in terms of the lines it uses.
- The touch objects cannot share X and Y lines if self-capacitance measurements are enabled
- It is recommended that the touchscreen should start at X0, Y0; if self-capacitance measurements are enabled, the touchscreen **must** start at X0, Y0

For optimal performance in terms of cycle time overhead, it is recommended that the number of X (drive) lines used is kept to the minimum and designs should favor using Y lines where possible.

6.2 Peripheral Touch Controller Keys

The mXT336T supports up to 7 Peripheral Touch Controller (PTC) lines (package dependent). These can be used as an array of mutual capacitance keys and can be configured as X (drive) or Y (receive) lines as required.

The PTC keys must be assigned to X or Y lines in a strict order. The lowest numbered pins, starting with PTCXY0, are assigned to the X lines, and the remainder of the pins are assigned as Y lines. There are three possible Sensor Modes (layouts) and the chosen mode must be configured in the PTC Key Set T97 protocol object (refer to the *mXT336T 2.3 Protocol Guide* for more information).

Note the following:

- Pin PTCXY1 can be used as a Y line only, so for sensor modes 1 and 2 (where PTCXY1 would be assigned as an X line), this pin is not used.
- If any of the PTCXY pins are in use for PTCXY lines, then none of the PTCXY pins is available for any alternative function (such as GPIO, NOISE_IN, and so on).
- On the UFQFN 56 and UFBGA 64 packages, there are only four available PTC pins. On these packages, only Sensor Mode 0 should be used.

The sensor modes are shown in the following tables.

Table 6-1. PTC Sensor Mode 0 – UFQFN 56 and UFBGA 64

		X Axis
		PTCXY0
Y Axis	PTCXY1	Key 0
	PTCXY2	Key 1
	PTCXY3	Key 2

Table 6-2. PTC Sensor Mode 0 – UFBGA 72

		X Axis	
		PTCXY0	
Y Axis	PTCXY1	Key 0	
	PTCXY2	Key 1	
	PTCXY3	Key 2	
	PTCXY4	Key 3	
	PTCXY5	Key 4	
	PTCXY6	Key 5	

Table 6-3. PTC Sensor Mode 1 – UFBGA 72

		X Axis		
		PTCXY0	PTCXY1	PTCXY2
Y Axis	PTCXY3	Key 0	Not used	Key 1
	PTCXY4	Key 2	Not used	Key 3
	PTCXY5	Key 4	Not used	Key 5
	PTCXY6	Key 6	Not used	Key 7

Table 6-4. PTC Sensor Mode 2 – UFBGA 72

		X Axis			
		PTCXY0	PTCXY1	PTCXY2	PTCXY3
Y Axis	PTCXY4	Key 0	Not used	Key 1	Key 2
	PTCXY5	Key 3	Not used	Key 4	Key 5
	PTCXY6	Key 6	Not used	Key 7	Key 8

7. Power-up / Reset Requirements

There is an internal Power-on Reset (POR) in the device.

If an external reset is to be used the device must be held in $\overline{\text{RESET}}$ (active low) while the digital (Vdd) analog (AVdd) and I/O (VddIO) power supplies are powering up. The supplies must have reached their nominal values before the $\overline{\text{RESET}}$ signal is deasserted (that is, goes high). This is shown in [Figure 7-1](#). See [Section 13.2 on page 51](#) for nominal values for Vdd, VddIO, and AVdd.

Figure 7-1. Power Sequencing on the mXT336T

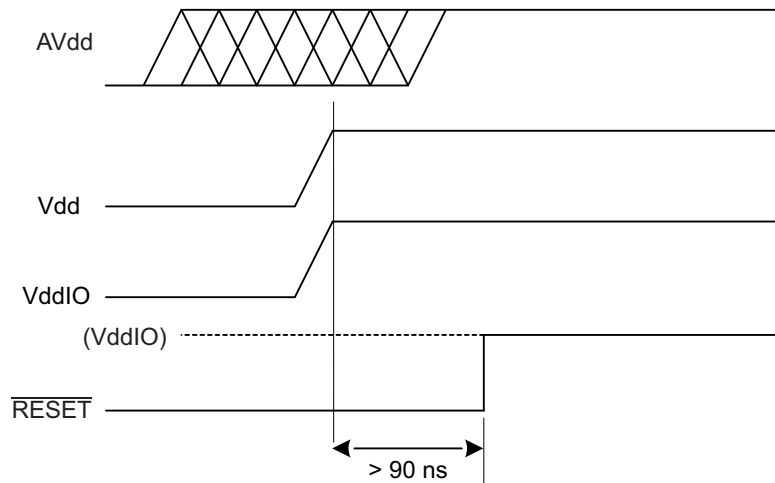

Note: When using external $\overline{\text{RESET}}$ at power-up, VddIO must not be enabled after Vdd

After power-up, the device takes 81 ms before it is ready to start communications.

If the $\overline{\text{RESET}}$ line is released before the AVdd supply has reached its nominal voltage (see [Figure 7-2 on page 32](#)), then some additional operations need to be carried out by the host. There are two options open to the host controller:

- Start the part in deep sleep mode and then send the command sequence to set the cycle time to wake the part and allow it to run normally. Note that in this case a calibration command is also needed.
- Send a reset command.

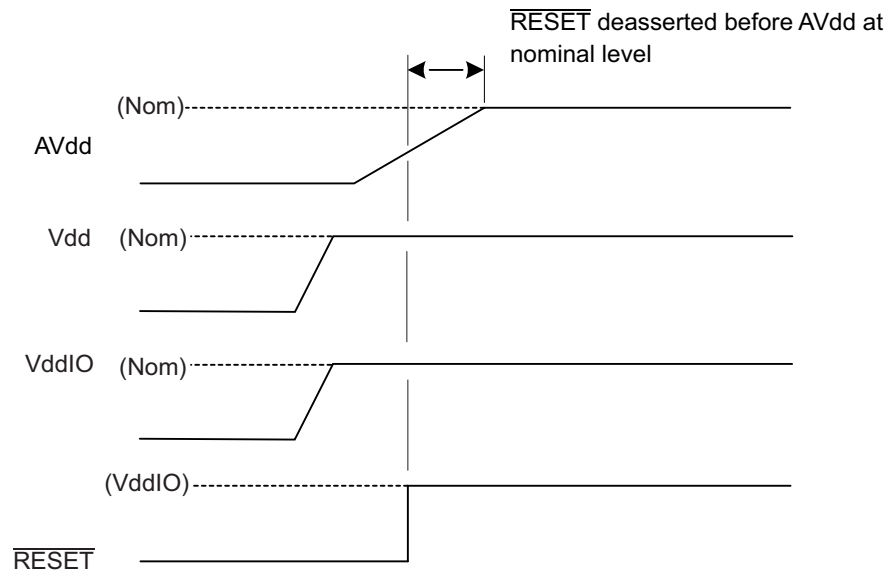
Figure 7-2. Power Sequencing on the mXT336T – Late rise on AVdd or XVdd

The $\overline{\text{RESET}}$ pin can be used to reset the device whenever necessary. The $\overline{\text{RESET}}$ pin must be asserted low for at least 90 ns to cause a reset. After releasing the $\overline{\text{RESET}}$ pin the device takes 80 ms before it is ready to start communications. It is recommended to connect the $\overline{\text{RESET}}$ pin to a host controller to allow it to initiate a full hardware reset without requiring a power-down.

Make sure that any lines connected to the device are below or equal to Vdd during power-up. For example, if $\overline{\text{RESET}}$ is supplied from a different power domain to the VDDIO pin, make sure that it is held low when Vdd is off. If this is not done, the $\overline{\text{RESET}}$ signal could parasitically couple power via the $\overline{\text{RESET}}$ pin into the Vdd supply.

Note that the voltage level on the $\overline{\text{RESET}}$ pin of the device must never exceed VddIO (digital supply voltage).

A software reset command can be used to reset the chip (refer to the Command Processor T6 object in the *mXT336T 2.3 Protocol Guide*). A software reset takes typically 100 ms. After the chip has finished it asserts the CHG line to signal to the host that a message is available. The reset flag is set in the Message Processor object to indicate to the host that it has just completed a reset cycle. This bit can be used by the host to detect any unexpected brownout events. This allows the host to take any necessary corrective actions, such as reconfiguration.

A checksum check is performed on the configuration settings held in the nonvolatile memory. If the checksum does not match a stored copy of the last checksum, then this indicates that the settings have become corrupted. This is signaled to the host by setting the configuration error bit in the message data for the Command Processor T6 object (refer to the *mXT336T 2.3 Protocol Guide* for more information).

Note that the $\overline{\text{CHG}}$ line is briefly set as an input during power-up or reset. It is therefore particularly important that the line should be allowed to float high via the $\overline{\text{CHG}}$ line pull-up resistor during this period. It should not be driven by the host (see [Table 13.8.3 on page 60](#)).

At power-on, the device performs a self-test routine to check for shorts that might cause damage to the device. Refer to the Self Test T25 object in the *mXT336T 2.3 Protocol Guide* for more details about this process.

7.1 Power-up and Reset Sequence – VddIO Enabled after Vdd

The Power-up sequence that can be used in applications where VddIO must be powered up after Vdd, is shown in [Figure 7-3](#).

In this case the communication interface to the maXTouch device is not driven by the host system. The $\overline{\text{RESET}}$ and $\overline{\text{CHG}}$ pins are connected to VddIO using suitable pull-up resistors. Vdd is powered up, followed by VddIO, no more than 10 ms after Vdd. Due to the pull-up resistors, $\overline{\text{RESET}}$ and $\overline{\text{CHG}}$ will rise with VddIO. The internal POR system ensures reliable boot up of the device and the $\overline{\text{CHG}}$ line will go low approximately 81 ms after Vdd to notify the host that the device is ready to start communication.

Figure 7-3. Power-up Sequence

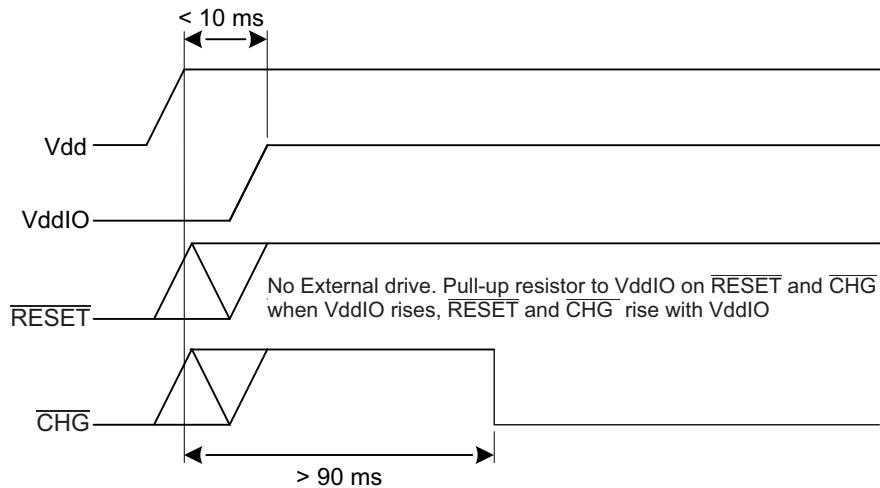

7.1.1 Summary

The Power-up and reset requirements for the maXTouch devices are summarized in [Table 7-1](#).

Table 7-1. Power-up and Reset Requirements

Condition	External $\overline{\text{RESET}}$	VddIO Delay (After Vdd)	AVdd Power-Up	Comments
1	Low at Power-up	0 ms	Before $\overline{\text{RESET}}$ is released	If AVdd bring-up is delayed then additional actions will be required by the host. See notes in Figure 7-1 on page 31
2	Not driven	$< 10\text{ ms}$	Before VddIO	

8. Detailed Operation

8.1 Touch Detection

The mXT336T allows for both mutual and self capacitance measurements, with the self capacitance measurements being used to augment the mutual capacitance measurements to produce reliable touch information.

When self capacitance measurements are enabled, touch classification is achieved using both mutual and self capacitance touch data. This has the advantage that both types of measurement systems can work together to detect touches under a wide variety of circumstances.

Mutual capacitance touch data is used wherever possible to classify touches as this has greater granularity than self capacitance measurements and provides positional information on touches. Refer to the *mXT336T 2.3 Protocol Guide* for more information on measurements.

Self capacitance measurements, on the other hand, allow for the detection of single touches in extreme case, such as single thick glove touches, when touches can only be detected by self capacitance data and may be missed by mutual capacitance touch detection.

8.2 Operational Modes

The device operates in two modes: Active (touch detected) and Idle (no touches detected). Both modes operate as a series of burst cycles. Each cycle consists of a short burst (during which measurements are taken) followed by an inactive sleep period. The difference between these modes is the length of the cycles. Those in idle mode typically have longer sleep periods. The cycle length is configured using the IDLEACQINT and ACTVACQINT settings in the Power Configuration T7. In addition, an *Active to Idle Timeout* setting is provided.

Refer to the *mXT336T 2.3 Protocol Guide* for full information on how these modes operate, and how to use the settings provided.

8.3 Detection Integrator

The device features a touch detection integration mechanism. This acts to confirm a detection in a robust fashion. A counter is incremented each time a touch has exceeded its threshold and has remained above the threshold for the current acquisition. When this counter reaches a preset limit the sensor is finally declared to be touched. If, on any acquisition, the signal is not seen to exceed the threshold level, the counter is cleared and the process has to start from the beginning.

The detection integrator is configured using the appropriate touch objects (Multiple Touch Touchscreen T100). Refer to the *mXT336T 2.3 Protocol Guide* for more information.

8.4 Sensor Acquisition

The maximum acquisition time for one X line on the mXT336T is 5 μ s. Care should be taken to ensure that the total time for one X line configured by the Acquisition Configuration T8 and CTE Configuration T46 objects do not exceed this (refer to the *mXT336T 2.3 Protocol Guide* for details on these objects).

8.5 Calibration

Calibration is the process by which a sensor chip assesses the background capacitance on each node. Nodes are only calibrated on reset and when:

- The node is enabled (that is, activated).

or

- The node is already enabled and one of the following applies:
 - The node is held in detect for longer than the Touch Automatic Calibration setting (refer to the *mXT336T 2.3 Protocol Guide* for more information on TCHAUTOCAL setting in the Acquisition Configuration object).

- The signal delta on a node is at least the touch threshold (TCHTHR) in the anti-touch direction, while it meets the criteria in the Touch Recovery Processes that results in a recalibration. (Refer to the *mXT336T 2.3 Protocol Guide* for objects Acquisition Configuration T8 and Self Capacitance Configuration T111).
- The host issues a recalibrate command.
- Certain configuration settings are changed.

A status message is generated on the start and completion of a calibration.

Note that the device performs a global calibration; that is, all the nodes are calibrated together.

8.6 Digital Filtering and Noise Suppression

The mXT336T supports on-chip filtering of the acquisition data received from the sensor. Specifically, the maXCharger T72 object provides an algorithm to suppress the effects of noise (for example, from a noisy charger plugged into the user's product). This algorithm can automatically adjust some of the acquisition parameters on-the-fly to filter the analog-to-digital conversions (ADCs) received from the sensor.

Additional noise suppression is provided by the Self Capacitance maXCharger T108 object. Similar in both design and configuration to the maXCharger T72 object, the Self Capacitance maXCharger T108 object is the noise suppression interface for self capacitance touch measurements.

Noise suppression is triggered when a noise source is detected.

- A hardware trigger can be implemented using the NOISE_IN pin.
- The host driver code can indicate when a noise source is present.
- The noise suppression is also triggered based on the noise levels detected using internal line measurements. The maXCharger T72 and Self Capacitance maXCharger T108 object selects the appropriate controls to suppress the noise present in the system.

Refer to the *mXT336T 2.3 Protocol Guide* for more information on the maXCharger T72 and Self Capacitance maXCharger T108 objects.

8.7 Shieldless Support and Display Noise Suppression

The mXT336T can support shieldless sensor design even with a noisy LCD by using the following features.

- **Optimal Integration:** This feature is not filtering as such, but enables the user to use a shorter integration window. The integration window optimizes the amount of charge collected against the amount of noise collected, to ensure an optimal SNR. This feature also benefits the system in the presence of an external noise source. This feature is configured using the Shieldless T56 object. Refer to the *mXT336T 2.3 Protocol Guide* for more information
- **Display noise suppression:** This feature is based on filtering provided by the Lens Bending T65 object (See [Section 8.10 on page 36](#)). This feature allows the device to overcome display noise simultaneously with external noise. Refer to the *mXT336T 2.3 Protocol Guide* for more information

8.8 Retransmission Compensation

The device can limit the undesirable effects on the mutual capacitance touch signals caused by poor device coupling to ground, such as poor sensitivity and touch break-up. This is achieved using the Retransmission Compensation T80 object. This object can be configured to allow the touchscreen to compensate for signal degradation due to these undesirable effects. If self capacitance measurements are also scheduled, the Retransmission Compensation T80 object will use the resultant data to enhance the compensation process.

The Retransmission Compensation T80 object is also capable of compensating for water presence on the sensor if self capacitance measurements are scheduled. In this case, both mutual capacitance and self capacitance measurements are used to detect moisture and then, once moisture is detected, self capacitance measurements are used to detect single touches in the presence of moisture.

Refer to the *mXT336T 2.3 Protocol Guide* for more information on the Retransmission Compensation T80 object.

8.9 Grip Suppression

The device has two grip suppression mechanisms to suppress false detections from a user's grip.

Mutual grip suppression works by specifying a boundary around a touchscreen, within which touches can be suppressed whilst still allowing touches in the center of the touchscreen. This ensures that a "rolling" hand touch (such as when a user grips a mobile device) is suppressed. A "real" (finger) touch towards the center of the screen is allowed.

Mutual grip suppression is configured using the Grip Suppression T40 object. There is one instance of the Grip Suppression T40 object for each Multiple Touch Touchscreen T100 object present on the device.

Refer to the *mXT336T 2.3 Protocol Guide* for more information on the Grip Suppression T40 object.

Self Capacitance grip suppression works by looking for characteristic shapes in the self capacitance measurement along the touchscreen boundary, and thereby distinguishing between a grip and a touch further into the sensor.

8.10 Lens Bending

The device supports algorithms to eliminate disturbances from the measured signal.

When the sensor suffers from the screen deformation (lens bending) the signal values acquired by normal procedure are corrupted by the disturbance component (bend). The amount of bend depends on:

- The mechanical and electrical characteristics of the sensor
- The amount and location of the force applied by the user touch to the sensor

The Lens Bending T65 object measures the bend component and compensates for any distortion caused by the bend. As the bend component is primarily influenced by the user touch force, it can be used as a secondary source to identify the presence of a touch. The additional benefit of the Lens Bending T65 object is that it will eliminate LCD noise as well. Refer to the *mXT336T 2.3 Protocol Guide* for more information on the Lens Bending T65 object.

8.11 Glove Detection

The device has glove detection algorithms that process the measurement data received from the touchscreen classifying touches as potential gloved touches.

The Glove Detection T78 object is used to detect glove touches. In Normal Mode the Glove Detection T78 object applies vigorous glove classification to small signal touches to minimize the effect of unintentional hovering finger reporting.

Once a gloved touch is found, the Glove Detection T78 object enters Glove Confidence Mode. In this mode the device expects the user to be wearing gloves so the classification process is much less stringent.

Refer to the *mXT336T 2.3 Protocol Guide* for more information on the Glove Detection T78 object.

8.12 Unintentional Touch Suppression

The Touch Suppression T42 object provides a mechanism to suppress false detections from unintentional touches from a large body area, such as from a face, ear or palm. The Touch Suppression T42 object also provides Maximum Touch Suppression to suppress all touches if more than a specified number of touches has been detected. There is one instance of the Touch Suppression T42 object for each Multiple Touch Touchscreen T100 object present on the device.

Refer to the *mXT336T 2.3 Protocol Guide* for more information on the Touch Suppression T42 object.

8.13 GPIO Pins

The mXT336T has 4 GPIO pins. The pins can be set to be either an input or an output, as required. Note that unused GPIO pins can be left externally unconnected as long as they are given a defined state by using the GPIO/PWM Configuration T19 object. With the GPIO/PWM Configuration T19 object, an unused GPIO pin can be either set to Input mode, with internal pull-up, or Output mode. If the GPIO/PWM Configuration T19 is not enabled for use, all the GPIO pins are unused.

By default GPIO pins are set to be inputs. If not used they should be connected to GND. Alternatively, they can be set as outputs using the GPIO/PWM Configuration T19 object and left open.

Note that GPIO pins are not available if any PTC lines are used.

9. I²C Communications

The device can use an I²C interface for communication.

The I²C interface is used in conjunction with the $\overline{\text{CHG}}$ line. The $\overline{\text{CHG}}$ line going active signifies that a new data packet is available. This provides an interrupt-style interface and allows the device to present data packets when internal changes have occurred.

9.1 I²C Address

The device supports one I²C device address – 0x4A. This is shifted left to form the SLA+W or SLA+R address when transmitted over the I²C interface, as shown in Figure 9-1.

Table 9-1. Format of an I²C Address

Bit 7	Bit 6	Bit 5	Bit 4	Bit 3	Bit 2	Bit 1	Bit 0
Address: 0x4A							Read/write

9.2 Writing To the Device

A WRITE cycle to the device consists of a START condition followed by the I²C address of the device (SLA+W). The next two bytes are the address of the location into which the writing starts. The first byte is the Least Significant Byte (LSByte) of the address, and the second byte is the Most Significant Byte (MSByte). This address is then stored as the address pointer.

Subsequent bytes in a multi-byte transfer form the actual data. These are written to the location of the address pointer, location of the address pointer + 1, location of the address pointer + 2, and so on. The address pointer returns to its starting value when the WRITE cycle STOP condition is detected.

Figure 9-1 shows an example of writing four bytes of data to contiguous addresses starting at 0x1234.

Figure 9-1. Example of a Four-byte Write Starting at Address 0x1234

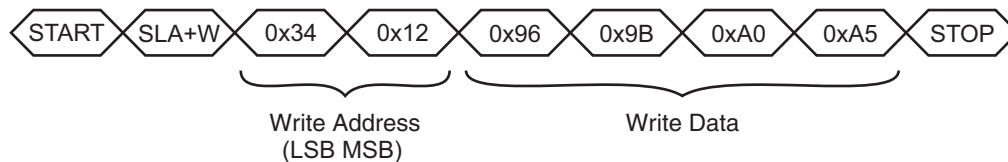

9.3 I²C Writes in Checksum Mode

In I²C checksum mode an 8-bit CRC is added to all I²C writes. The CRC is sent at the end of the data write as the last byte before the STOP condition. All the bytes sent are included in the CRC, including the two address bytes. Any command or data sent to the device is processed even if the CRC fails.

To indicate that a checksum is to be sent in the write, the most significant bit of the MSByte of the address is set to 1. For example, the I²C command shown in Figure 9-2 writes a value of 150 (0x96) to address 0x1234 with a checksum. The address is changed to 0x9234 to indicate checksum mode.

Figure 9-2. Example of a Write To Address 0x1234 With a Checksum

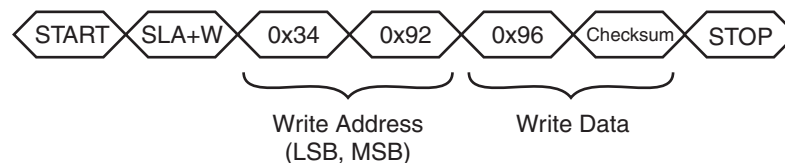

9.4 Reading From the Device

Two I²C bus activities must take place to read from the device. The first activity is an I²C write to set the address pointer (LSByte then MSByte). The second activity is the actual I²C read to receive the data. The address pointer returns to its starting value when the read cycle NACK is detected.

It is not necessary to set the address pointer before every read. The address pointer is updated automatically after every read operation. The address pointer will be correct if the reads occur in order. In particular, when reading multiple messages from the Message Processor T5 object, the address pointer is automatically reset to allow continuous reads (see Section 9.5).

The WRITE and READ cycles consist of a START condition followed by the I²C address of the device (SLA+W or SLA+R respectively).

Figure 9-3 shows the I²C commands to read four bytes starting at address 0x1234.

Figure 9-3. Example of a Four-byte Read Starting at Address 0x1234

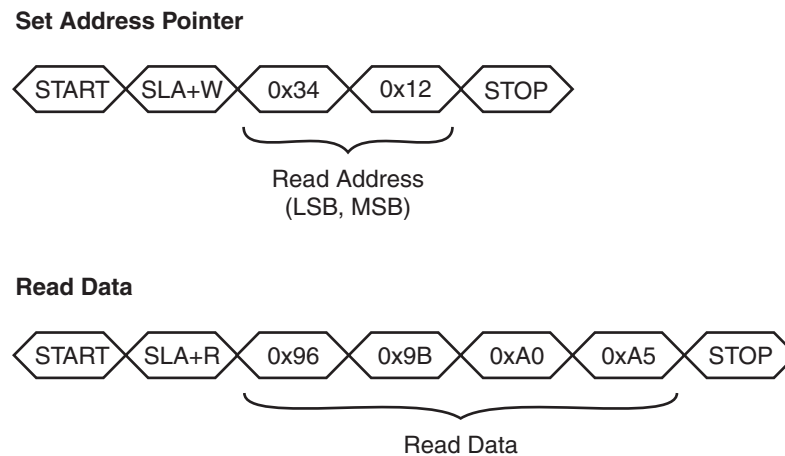

9.5 Reading Status Messages with DMA

The device facilitates the easy reading of multiple messages using a single continuous read operation. This allows the host hardware to use a direct memory access (DMA) controller for the fast reading of messages, as follows:

1. The host uses a write operation to set the address pointer to the start of the Message Count T44 object, if necessary ⁽¹⁾. If a checksum is required on each message, the most significant bit of the MSByte of the read address must be set to 1.
2. The host starts the read operation of the message by sending a START condition.
3. The host reads the Message Count T44 object (one byte) to retrieve a count of the pending messages (refer to the *mXT336T 2.3 Protocol Guide* for details).
4. The host calculates the number of bytes to read by multiplying the message count by the size of the Message Processor T5 object ⁽²⁾.
5. Note that the size of the Message Processor T5 object as recorded in the Object Table includes a checksum byte. If a checksum has not been requested, one byte should be deducted from the size of the object. That is: number of bytes = count × (size – 1).
6. The host reads the calculated number of message bytes. It is important that the host does *not* send a STOP condition during the message reads, as this will terminate the continuous read operation and reset the address pointer. No START and STOP conditions must be sent between the messages.

1. The STOP condition at the end of the read resets the address pointer to its initial location, so it may already be pointing at the Message Count T44 object following a previous message read.

2. The host should have already read the size of the Message Processor T5 object in its initialization code.

- The host sends a STOP condition at the end of the read operation after the last message has been read. The NACK condition immediately before the STOP condition resets the address pointer to the start of Message Count T44 object.

Figure 9-4 shows an example of using a continuous read operation to read three messages from the device without a checksum. Figure 9-5 on page 40 shows the same example with a checksum.

Figure 9-4. Continuous Message Read Example – No Checksum

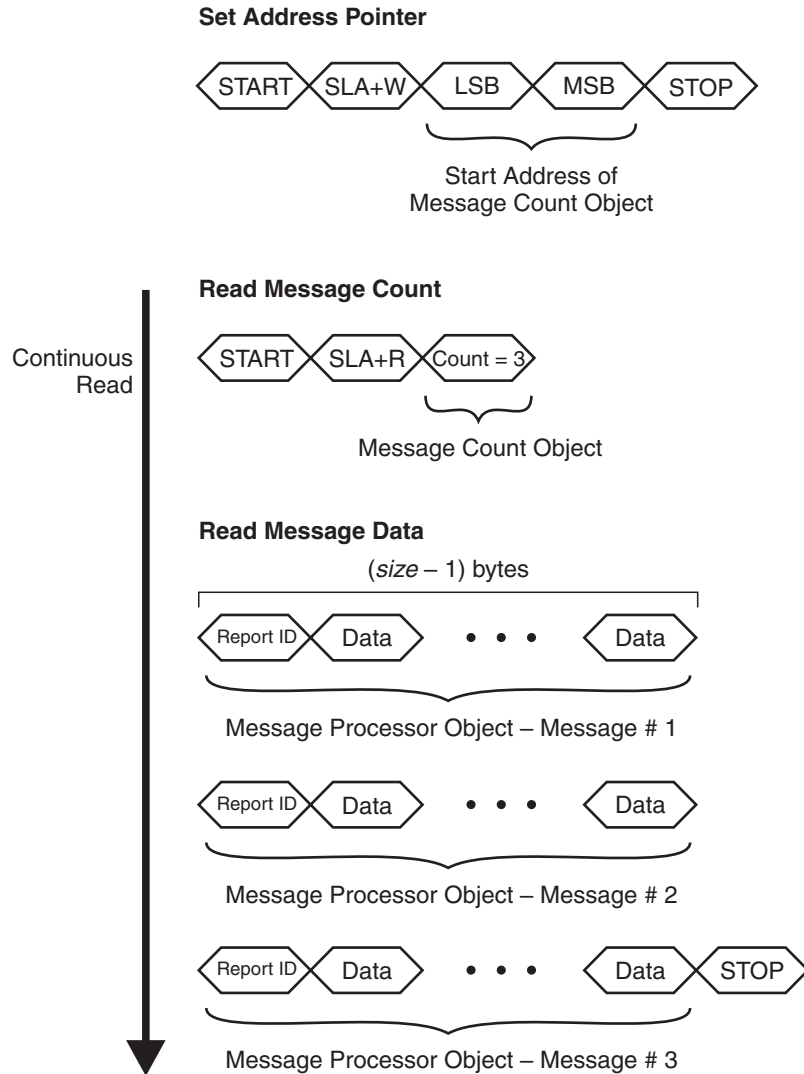
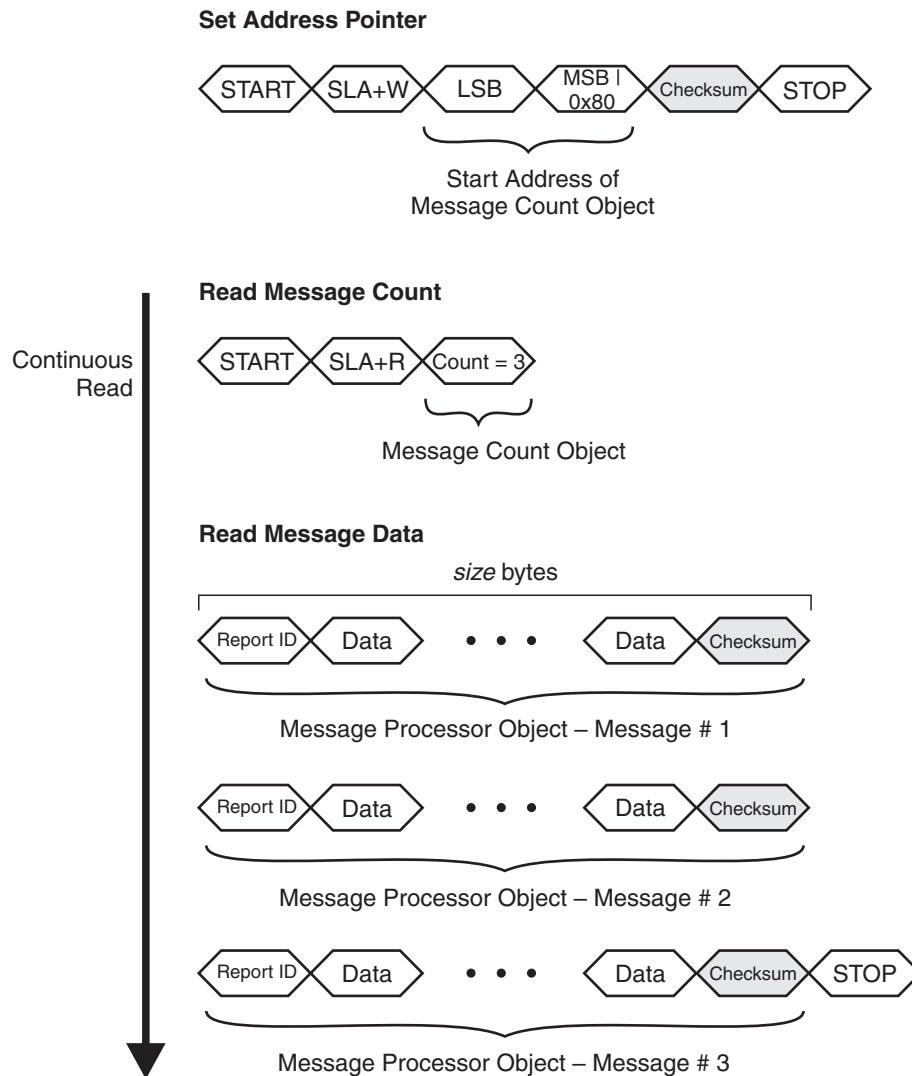

Figure 9-5. Continuous Message Read Example – I²C Checksum Mode

There are no checksums added on any other I²C reads. An 8-bit CRC can be added, however, to all I²C writes, as described in [Section 9.3 on page 37](#).

An alternative method of reading messages using the $\overline{\text{CHG}}$ line is given in [Section 9.6](#).

9.6 $\overline{\text{CHG}}$ Line

The $\overline{\text{CHG}}$ line is an active-low, open-drain output that is used to alert the host that a new message is available in the Message Processor T5 object. This provides the host with an interrupt-style interface with the potential for fast response times. It reduces the need for wasteful I²C communications.

The $\overline{\text{CHG}}$ line remains low as long as there are messages to be read. The host should be configured so that the $\overline{\text{CHG}}$ line is connected to an interrupt line that is level-triggered. The host should not use an edge-triggered interrupt as this means adding extra software precautions.

The $\overline{\text{CHG}}$ line should be allowed to float during normal usage. This is particularly important after power-up or reset (see [Section 7. on page 31](#)).

A pull-up resistor is required, typically 3.3 k Ω to VddIO.

The $\overline{\text{CHG}}$ line operates in two modes, as defined by the Communications Configuration T18 object (refer to the *mXT336T 2.3 Protocol Guide*).

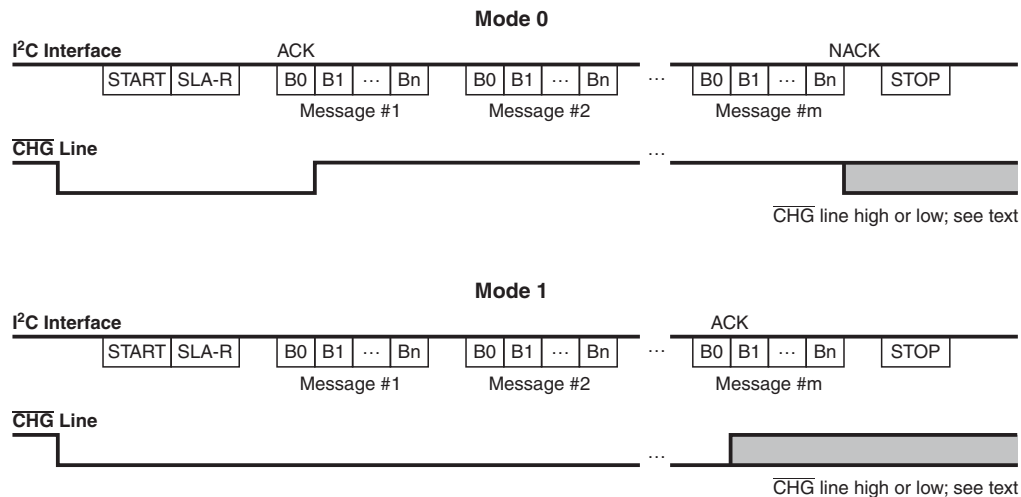
Figure 9-6. $\overline{\text{CHG}}$ Line Modes for I²C-compatible Transfers**In Mode 0:**

1. The $\overline{\text{CHG}}$ line goes low to indicate that a message is present.
2. The $\overline{\text{CHG}}$ line goes high when the first byte of the first message (that is, its report ID) has been sent and acknowledged (ACK sent) and the next byte has been prepared in the buffer.
3. The STOP condition at the end of an I²C transfer causes the $\overline{\text{CHG}}$ line to stay high if there are no more messages. Otherwise the $\overline{\text{CHG}}$ line goes low to indicate a further message.

Mode 0 allows the host to continually read messages. Messaging reading ends when a report ID of 255 (“invalid message”) is received. Alternatively the host ends the transfer by sending a NACK after receiving the last byte of a message, followed by a STOP condition. If and when there is another message present, the $\overline{\text{CHG}}$ line goes low, as in step 1. In this mode the state of the $\overline{\text{CHG}}$ line does not need to be checked during the I²C read.

In Mode 1:

1. The $\overline{\text{CHG}}$ line goes low to indicate that a message is present.
2. The $\overline{\text{CHG}}$ line remains low while there are further messages to be sent after the current message.
3. The $\overline{\text{CHG}}$ line goes high again only once the first byte of the last message (that is, its report ID) has been sent and acknowledged (ACK sent) and the next byte has been prepared in the output buffer.

Mode 1 allows the host to continually read the messages until the $\overline{\text{CHG}}$ line goes high, and the state of the $\overline{\text{CHG}}$ line determines whether or not the host should continue receiving messages from the device.

Note: The state of the $\overline{\text{CHG}}$ line should be checked only between messages and not between the bytes of a message. The precise point at which the $\overline{\text{CHG}}$ line changes state cannot be predicted and so the state of the $\overline{\text{CHG}}$ line cannot be guaranteed between bytes.

The Communications Configuration T18 object can be used to configure the behavior of the $\overline{\text{CHG}}$ line. In addition to the $\overline{\text{CHG}}$ line operation modes described above, this object allows the use of edge-based interrupts, as well as direct control over the state of the $\overline{\text{CHG}}$ line. Refer to the *mXT336T 2.3 Protocol Guide* for more information.

9.7 SDA, SCL

The I²C bus transmits data and clock with SDA and SCL, respectively. These are open-drain. The device can only drive these lines low or leave them open. The termination resistors (R_p) pull the line up to V_{dd} if no I²C device is pulling it down.

The termination resistors should be chosen so that the rise times on SDA and SCL meet the I²C specifications for the interface speed being used, bearing in mind other loads on the bus (see [Section 13.10 on page 60](#)).

9.8 Clock Stretching

The device supports clock stretching in accordance with the I²C specification. It may also instigate a clock stretch if a communications event happens during a period when the device is busy internally. The maximum clock stretch is approximately 10 – 15 ms.

The device has an internal bus monitor that can reset the internal I²C hardware if SDA or SCL is stuck low for more than 200 ms. This means that if a prolonged clock stretch of more than 200 ms is seen by the device, then any ongoing transfers with the device may be corrupted. The bus monitor is enabled or disabled using the Communications Configuration T18 object. Refer to the *mXT336T 2.3 Protocol Guide* for more information.

10. PCB Design Considerations

10.1 Introduction

The following sections give the design considerations that should be adhered to when designing a PCB layout for use with the mXT336T. Of these, power supply and ground tracking considerations are the most critical.

By observing the following design rules, and with careful preparation for the PCB layout exercise, designers will be assured of a far better chance of success and a correctly functioning product.

10.2 Printed Circuit Board

Atmel recommends the use of a four-layer printed circuit board for mXT336T applications. This, together with careful layout, will ensure that the board meets relevant EMC requirements for both noise radiation and susceptibility, as laid down by the various national and international standards agencies.

10.2.1 PCB Cleanliness

Modern no-clean-flux is generally compatible with capacitive sensing circuits.



CAUTION: If a PCB is reworked to correct soldering faults relating to any of the device devices, or to any associated traces or components, be sure that you fully understand the nature of the flux used during the rework process. Leakage currents from hygroscopic ionic residues can stop capacitive sensors from functioning. If you have any doubts, a thorough cleaning after rework may be the only safe option.

10.3 Supply Rails and Ground Tracking

Power supply and clock distribution are the most critical parts of any board layout. Because of this, it is advisable that these be completed before any other tracking is undertaken. After these, supply decoupling, and analog and high speed digital signals should be addressed. Track widths for all signals, especially power rails should be kept as wide as possible in order to reduce inductance.

The Power and Ground planes themselves can form a useful capacitor. Flood filling for either or both of these supply rails, therefore, should be used where possible. It is important to ensure that there are no floating copper areas remaining on the board: all such areas should be connected to the 0 V plane. The flood filling should be done on the outside layers of the board.

10.4 Power Supply Decoupling

As a rule, a suitable decoupling capacitor should be placed on each and every supply pin on all digital devices. It is important that these capacitors are placed as close to the chip supply pins as possible (less than 10 mm away). The ground connection of these capacitors should be tracked to 0 V by the shortest, heaviest traces possible.

Capacitors with a Type II dielectric, such as X5R or X7R and with a value of at least 100 nF, should be used for this purpose.

In addition, at least one 'bulk' decoupling capacitor, with a minimum value of 4.7 μ F should be placed on each power rail, close to where the supply enters the board.

Surface mounting capacitors are preferred to wire leaded types due to their lower ESR and ESL. It is often possible to fit these decoupling capacitors underneath and on the opposite side of the PCB to the digital ICs. This will provide the shortest tracking, and most effective decoupling possible.

Refer to the application note *Selecting Decoupling Capacitors for Atmel PLDs* (doc0484.pdf; available on the Atmel website) for further general information on decoupling capacitors.

10.5 Single Supply Operation

When designing a PCB for an application using a single LDO, extra care should be taken to ensure short, low inductance traces between the supply and the touch controller supply input pins. Ideally, tracking for the individual supplies should be arranged in a star configuration, with the LDO at the junction of the star. This will ensure that supply current variations or noise in one supply rail will have minimum effect on the other supplies. In applications where a ground plane is not practical, this same star layout should also apply to the power supply ground returns.

10.6 Analog I/O

In general, tracking for the analog I/O signals from the device should be kept as short as possible. These normally go to a connector which interfaces directly to the touchscreen.

Ensure that adequate ground-planes are used. An analog ground plane should be used in addition to a digital one. Care should be taken to ensure that both ground planes are kept separate and are connected together only at the point of entry for the power to the PCB. This is usually at the input connector.

10.7 Component Placement and Tracking

It is important to orient all devices so that the tracking for important signals (such as power and clocks) are kept as short as possible. This simple point is often overlooked when initially planning a PCB layout and can save hours of work at a later stage.

10.7.1 Digital Signals

In general, when tracking digital signals, it is advisable to avoid sharp directional changes, sensitive signal tracks (such as analog I/O) and any clock or crystal tracking.

A good ground return path for all signals should be provided, where possible, to ensure that there are no discontinuities in the ground return path.

10.7.2 UQFN Package Restrictions

The central pad on the underside of the UQFN device should be connected to ground. Do not run any tracks underneath the body of the device, only ground. [Figure 10-1](#) shows an example of good/bad tracking.

Figure 10-1. Examples of Good and Bad Tracking

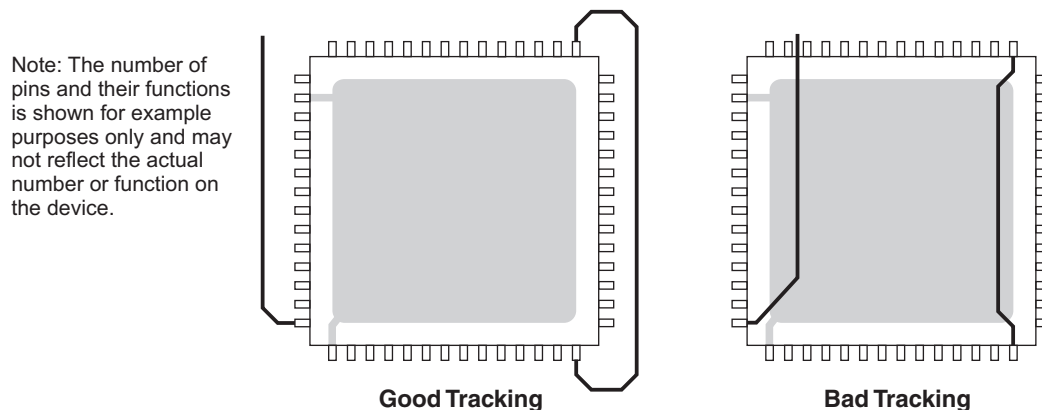

10.8 EMC and Other Observations

The following recommendations are not mandatory, but may help in situations where particularly difficult EMC or other problems are present:

- Try to keep as many signals as possible on the inside layers of the board. If suitable ground flood fills are used on the top and bottom layers, these will provide a good level of screening for noisy signals, both into and out of the PCB.
- Ensure that the on-board regulators have sufficient tracking around and underneath the devices to act as a heatsink. This heatsink will normally be connected to the 0 V or ground supply pin. Increasing the width of the copper tracking to any of the device pins will aid in removing heat. There should be no solder mask over the copper track underneath the body of the regulators.
- Ensure that the decoupling capacitors, especially high capacity ceramic type, have the requisite low ESR, ESL and good stability/temperature properties. Refer to the regulator manufacturer's datasheet for more information.

11. Getting Started with mXT336T

11.1 Establishing Contact

11.1.1 Communication with the Host

The host can use the following interface to communicate with the device:

- I²C interface (see [Section 9. on page 37](#))

11.1.2 Power-up Sequence

On power-up, the $\overline{\text{CHG}}$ line goes low to indicate that there is new data to be read from the Message Processor T5 object. If the $\overline{\text{CHG}}$ line does not go low, there is a problem with the device.

The host should attempt to read any available messages to establish that the device is present and running following power-up or a reset. Examples of messages include reset or calibration messages. The host should also check that there are no configuration errors reported.

11.2 Using the Object Protocol

The device has an object-based protocol that is used to communicate with the device. Typical communication includes configuring the device, sending commands to the device, and receiving messages from the device. Refer to the *mXT336T 2.3 Protocol Guide* for more information.

The host must perform the following initialization so that it can communicate with the device:

1. Read the start positions of all the objects in the device from the Object Table and build up a list of these addresses.
2. Use the Object Table to calculate the report IDs so that messages from the device can be correctly interpreted.

11.2.1 Classes of Objects

The mXT336T contains the following classes of objects:

- **Debug objects** – provide a raw data output method for development and testing.
- **General objects** – required for global configuration, transmitting messages and receiving commands.
- **Touch objects** – operate on measured signals from the touch sensor and report touch data.
- **Signal processing objects** – process data from other objects (typically signal filtering operations).
- **Support objects** – provide additional functionality on the device.

11.2.2 Object Instances

Table 11-1. Objects on the mXT336T

Object	Description	Number of Instances	Usage
Debug Objects			
Diagnostic Debug T37	Allows access to diagnostic debug data to aid development.	1	Debug commands only. No configuration/tuning necessary. Not for use in production.
General Objects			
Message Processor T5	Handles the transmission of messages. This object holds a message in its memory space for the host to read.	1	No configuration necessary.
Command Processor T6	Performs a command when written to. Commands include reset, calibrate and backup settings	1	No configuration necessary.

Table 11-1. Objects on the mXT336T (Continued)

Object	Description	Number of Instances	Usage
Power Configuration T7	Controls the sleep mode of the device. Power consumption can be lowered by controlling the acquisition frequency and the sleep time between acquisitions.	1	Must be configured before use.
Acquisition Configuration T8	Controls how the device takes each capacitive measurement.	1	Must be configured before use.
Touch Objects			
PTC Key Set T97	Configures the PTC keys.	4	Enable and configure as required.
Multiple Touch Touchscreen T100	Creates a Touchscreen that supports the tracking of more than one touch.	1	Enable and configure as required.
Signal Processing Objects			
Grip Suppression T40	Suppresses false detections caused, for example, by the user gripping the edge of the touchscreen.	1	Enable and configure as required.
Touch Suppression T42	Suppresses false detections caused, for example, by the user placing their face too near the touchscreen on a mobile phone.	1	Enable and configure as required.
Shieldless T56	Allows a sensor to use true single-layer coplanar construction.	1	Enable and configure as required.
Lens Bending T65	Compensates for lens deformation (lens bending) by attempting to eliminate the disturbance signal from the reported deltas.	3	Enable and configure as required.
maXCharger T72	Performs various noise reduction techniques during touchscreen signal acquisition.	1	Enable and configure as required.
Glove Detection T78	Allows for the reporting of glove touches.	1	Enable and configure as required.
Retransmission Compensation T80	Limits the negative effects on touch signals caused by poor device coupling to ground.	1	Enable and configure as required.
Unlock Gesture T81	Sends a message when a gesture satisfies the configuration settings for use in wake up or unlock situations.	4	Enable and configure as required.
Touch Sequence Processor T93	Captures a sequence of touch and release locations to allow double taps to be detected.	1	Enable and configure as required.
PTC Noise Suppression T98	Provides noise suppression for PTC key measurements.	1	Enable and configure as required.
Self Capacitance maXCharger T108	Suppresses the effects of external noise within the context of self capacitance touch measurements.	1	Enable and configure as required.
Self Capacitance Grip Suppression T112	Allows contacting and hovering touches to be reported from the self capacitance measurements while the device is being gripped.	1	Enable and configure as required.

Table 11-1. Objects on the mXT336T (Continued)

Object	Description	Number of Instances	Usage
Symbol Gesture Processor T115	Detects arbitrary shaped gestures as a series of ordinal strokes. These are typically symbols drawn by the user for interpretation by the host as wake-up gestures or other application triggers.	1	Enable and configure as required.
Sensor Correction T121	Allows adjustments to be made to mutual measurements from an associated touchscreen sensor.	1	Enable and configure as required.
Support Objects			
Communications Configuration T18	Configures additional communications behavior for the device.	1	Check and configure as necessary.
GPIO/PWM Configuration T19	Creates a bank of digital I/O pins. These pins can then be controlled from the host by writing to the object's configuration memory space.	1	Enable and configure as required.
Self Test T25	Configures and performs self-test routines to find faults on a touch sensor.	1	Pin test commands only. No configuration/tuning necessary. Not for use in production.
User Data T38	Provides a data storage area for user data.	1	Read-only object. Configure as required.
Message Count T44	Provides a count of pending messages.	1	Read only object.
CTE Configuration T46	Controls the capacitive touch engine for the device.	1	Must be configured.
Timer T61	Provides control of a timer.	6	Enable and configure as required.
Serial Data Command T68	Provides an interface for the host driver to deliver various data sets to the device.	1	Enable and configure as required.
Dynamic Configuration Controller T70	Allows rules to be defined that respond to system events.	20	Enable and configure as required.
Dynamic Configuration Container T71	Allows the storage of user configuration on the device that can be selected in run-time based on rules defined in the T70 object.	1	Configure if Dynamic Configuration Controller T70 is in use.
PTC Configuration T95	Configures the Peripheral Touch Controller (PTC).	1	Check and configure as required.
PTC Tuning Parameters T96	Provides configuration space for a generic set of settings for PTC measurements.	1	Use under the guidance of Atmel field engineers only.
Auxiliary Touch Configuration T104	Allows the setting of self capacitance gain and thresholds for a particular measurement to generate auxiliary touch data for use by other objects.	1	Enable and configure if using self capacitance measurements
Self Capacitance Global Configuration T109	Provides configuration for a self capacitance measurements employed on the device.	1	Check and configure as required (if using self capacitance measurements).
Self Capacitance Tuning Parameters T110	Provides configuration space for a generic set of settings for self capacitance measurements.	6	Use under the guidance of Atmel field engineers only.

Table 11-1. Objects on the mXT336T (Continued)

Object	Description	Number of Instances	Usage
Self Capacitance Configuration T111	Provides configuration for a self capacitance measurements employed on the device.	2	Check and configure as required (if using self capacitance measurements).
Self Capacitance Measurement Configuration T113	Configures self capacitance measurements to generate data for use by other objects.	1	Enable and configure as required.
Symbol Gesture Configuration T116	Stores configuration data that defines the symbols to be detected by the Symbol Gesture Processor T115 object.	1	Configure if Symbol Gesture Processor T115 is in use.

11.2.3 Configuring and Tuning the Device

The objects are designed such that a default value of zero in their fields is a “safe” value that typically disables functionality. The objects must be configured before use and the settings written to the nonvolatile memory using the Command Processor T6 object.

Perform the following actions for each object:

1. Enable the object, if the object requires it.
2. Configure the fields in the object, as required.
3. Enable reporting, if the object supports messages, to receive messages from the object.

For information on configuring and tuning the mXT336T, refer to the following document:

- *maXTouch T Series Tuning Guide*

Refer also to the *mXT336T 2.3 Protocol Guide* for detailed information on the configuration parameters for the objects.

11.3 Writing to the Device

There are a number of mechanisms for writing to the device:

- Using an I²C write operation (see [Section 9.2 on page 37](#)).

To communicate with the device, you write to the appropriate object:

- To send a command to the device, you write the appropriate command to the Command Processor T6 object (refer to the *mXT336T 2.3 Protocol Guide*).
- To configure the device, you write to an object. For example, to configure the device power consumption you write to the global Power Configuration T7 object, and to set up a touchscreen you write to a Multiple Touch Touchscreen T100 object. Some objects are optional and need to be enabled before use. Refer to the *mXT336T 2.3 Protocol Guide* for more information on the objects.

11.4 Reading from the Device

Status information is stored in the Message Processor T5 object. This object can be read to receive any status information from the device. The following mechanisms provide an interrupt-style interface for reading messages in the Message Processor T5 object:

- The $\overline{\text{CHG}}$ line is asserted whenever a new message is available in the Message Processor T5 object (see [Section 9.6 on page 40](#)). See [Section 9.4 on page 38](#) for information on the format of the I²C read operation.

Note that the host should always wait to be notified of messages. The host should not poll the device for messages.

12. Debugging and Tuning

12.1 Hardware SPI Debug Interface

This interface is used for tuning and debugging when running the system and allows the development engineer's PC running Atmel maXTouch Studio to read the real-time raw data using the low-level debug port. This can be accessed via the SPI interface.

Note: The Primary Debug Interface cannot be used with a device using USB communications.

The SPI debug interface consists of the DBG_CLK, DBG_DAT and $\overline{\text{DBG_SS}}$ lines. These pins should be routed to test points on all designs such that they can be connected to external hardware during system development. These lines should not be connected to power or GND.

The touch controller will take care of the pin configuration. When these lines are in use, any alternative function for the pins cannot be used.

The Hardware interface is enabled by the Command Processor T6 object and by default will be off.

Refer to the following documents for more information:

- *mXT336T 2.3 Protocol Guide* for information on the Command Processor T6 object
- QTAN0050, *Using the maXTouch Debug Port*, for information on using the debug port
- *maXTouch T Series Tuning Guide* (distributed with Atmel approval only) for guidance on using the debug interface for tuning purposes

12.2 Object-based Protocol

The device provides a mechanism for obtaining raw data for development and testing purposes by reading data from the Diagnostic Debug T37 object. Refer to the *mXT336T 2.3 Protocol Guide* for more information on this object.

Note that the Diagnostic Debug T37 is of most use for simple tuning purposes. When debugging a design, it is preferable to use a hardware debug interface, as this will have a much higher bandwidth and can provide real time data.

12.3 Self Test

There is also a Self Test T25 object that runs self-test routines in the device to find hardware faults on the sense lines and the electrodes. This object also performs an initial pin fault test on power-up to ensure that there is no X-to-Y short before the high-voltage supply is enabled inside the chip. A high-voltage short into the analog circuitry would break the device.

Refer to the *mXT336T 2.3 Protocol Guide* for more information on the Self Test T25 object.

13. Specifications

13.1 Absolute Maximum Specifications

Vdd	3.6 V
VddIO	3.6 V
AVdd	3.6 V
XVdd	9.0 V
Voltage forced onto any pin	-0.3 V to (Vdd, VddIO or AVdd) + 0.3 V
Configuration parameters maximum writes (flash memory write cycles)	10,000



CAUTION: Stresses beyond those listed under *Absolute Maximum Specifications* may cause permanent damage to the device. This is a stress rating only and functional operation of the device at these or other conditions beyond those indicated in the operational sections of this specification is not implied. Exposure to absolute maximum specification conditions for extended periods may affect device reliability.

13.2 Recommended Operating Conditions

Operating temp	-40°C to +85°C
Storage temp	-60°C to +150°C
Vdd	3.3 V
VddIO	1.8 V to 3.3 V
AVdd	3.3 V
XVdd with internal voltage doubler	Vdd to 2 × Vdd
Cx transverse load capacitance per channel	0.6 pF to 3 pF
Temperature slew rate	10°C/min

13.3 DC Characteristics

13.3.1 Analog Voltage Supply – AVdd

Parameter	Min	Typ	Max	Units	Notes
Operating limits	2.7	3.3	3.47	V	
Supply Rise Rates	–	–	0.25	V/ μ s	

13.3.2 Digital Voltage Supply

Parameter	Min	Typ	Max	Units	Notes
VddIO					
Operating limits	1.71	–	3.47	V	I ² C-compatible. For compatibility with future devices in the same chip family, VddIO should be at the same level as Vdd.
Supply Rise Rates	–	–	0.25	V/ μ s	
Vdd					
Operating limits	3.0	3.3	3.47	V	
Supply Rise Rates	–	–	0.25	V/ μ s	

13.4 Test Configuration

The values listed below were used in the reference unit to validate the interfaces and derive the characterization data provided in the following sections.

See *mXT336T 2.3 Protocol Guide* for information about the individual objects and their fields.

The values for the user application will depend on the circumstances of that particular project and will vary from those listed here. Further tuning will be required to achieve an optimal performance.

Table 13-1. Test Configuration

Object/Parameter	Description/Setting
Acquisition Configuration T8	
CHRGTIME	35
MEASALLOW	11
MEASIDLEDEF	2
MEASACTVDEF	2
CTE Configuration T46	
IDLESYNCSPERX	16
ACTVSYNCSPERX	16
Shieldless T56	Object Enabled
INTTIME	30
Lens Bending T65 Instance 0	Object Enabled
maXCharger T72	Object Enabled
Retransmission Compensation T80	Object Enabled
PTC Key Set T97 Instance 0	Object Enabled
PTC Key Set T97 Instance 1	Object Enabled
PTC Key Set T97 Instance 2	Object Enabled
PTC Noise Suppression T98	Object Enabled
Multiple Touch Touchscreen T100	Object Enabled
XSIZE	24
YSIZE	14
Auxiliary Touch Configuration T104	Object Enabled
Self Capacitance Configuration T111 Instance 0	
INTTIME	60
IDLESYNCSPERL	24
ACTVSYNCSPERL	24

Table 13-1. Test Configuration

Object/Parameter	Description/Setting
Self Capacitance Configuration T111 Instance 1	
INTTIME	60
IDLESYNCSPERL	32
ACTVSYNCSPERL	32
Self Capacitance Measurement Configuration T113	Object Enabled

13.5 Current Consumption

13.5.1 AVdd

Acquisition Rate (ms)	0 Touches (mA)	1 Touch (mA)	2 Touches (mA)	5 Touches (mA)
Free-run	4.99	5.12	6.25	6.26
10	1.85	1.82	3.45	3.42
16	1.17	1.22	2.12	2.13
32	0.57	0.68	1.10	1.11
64	0.31	0.41	0.49	0.51
128	0.16	0.21	0.23	0.24
254	0.07	0.09	0.08	0.12

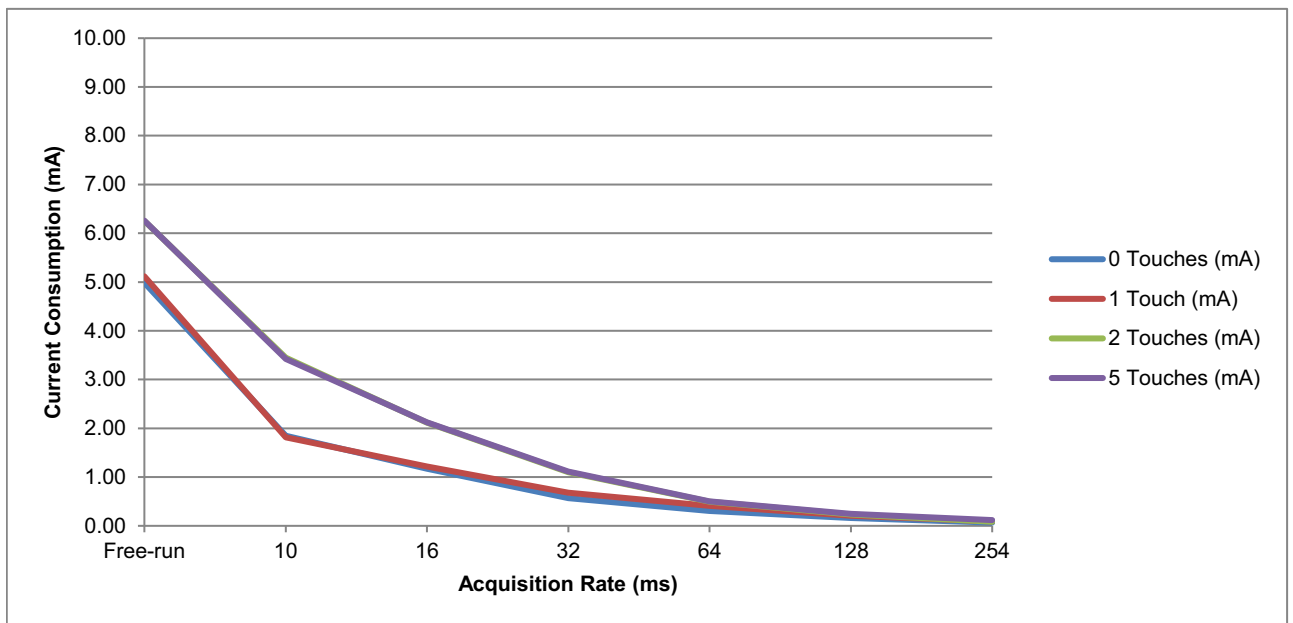

13.5.2 Vdd

Acquisition Rate (ms)	0 Touches (mA)	1 Touch (mA)	2 Touches (mA)	5 Touches (mA)
Free-run	9.34	10.15	10.67	11.68
10	5.06	5.13	6.60	7.46
16	3.88	3.96	4.95	5.36
32	2.22	2.28	2.81	2.91
64	1.22	1.31	1.44	1.62
128	0.72	0.76	0.83	0.88
254	0.51	0.52	0.45	0.46

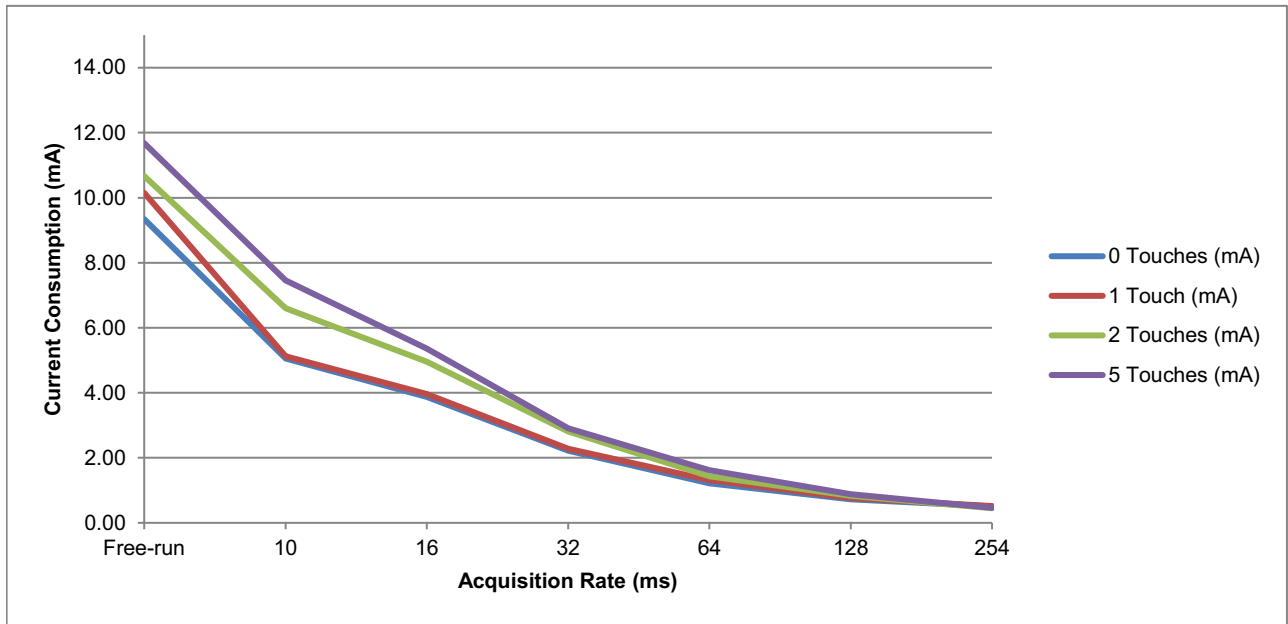

13.5.3 VddIO

Acquisition Rate (ms)	0 Touches (mA)	1 Touch (mA)	2 Touches (mA)	5 Touches (mA)
Free-run	0.0007	0.81	0.81	0.81
10	0.0008	0.81	0.81	0.81
16	0.0008	0.81	0.81	0.81
32	0.0008	0.81	0.81	0.81
64	0.0008	0.81	0.81	0.81
128	0.0008	0.81	0.81	0.81
254	0.0007	0.81	0.81	0.81

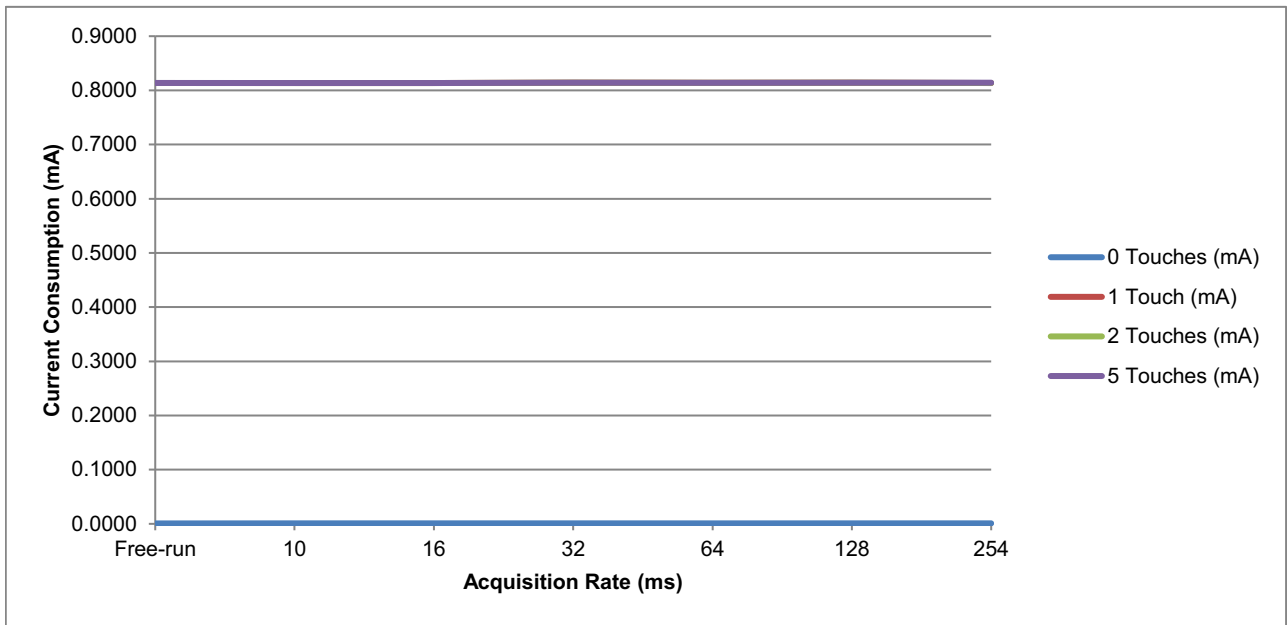

13.6 Deep Sleep Current

$T_A = 25^\circ\text{C}$

Parameter	Min	Typ	Max	Units	Notes
Deep Sleep Current	–	135	–	μA	Vdd = 3.3 V, AVdd = 3.3 V
Deep Sleep Power	–	445.5	–	μW	Vdd = 3.3 V, AVdd = 3.3 V

13.7 Power Supply Ripple and Noise

Parameter	Min	Typ	Max	Units	Notes
Vdd	–	–	±50	mV	Across frequency range 1 Hz to 1 MHz
AVdd	–	–	±50	mV	Across frequency range 1 Hz to 1 MHz
AVdd (with noise suppression enabled)	–	–	±40	mV	Across frequency range 1 Hz to 1 MHz, with Noise Suppression enabled

13.8 Timing Specifications

13.8.1 Refresh Rate

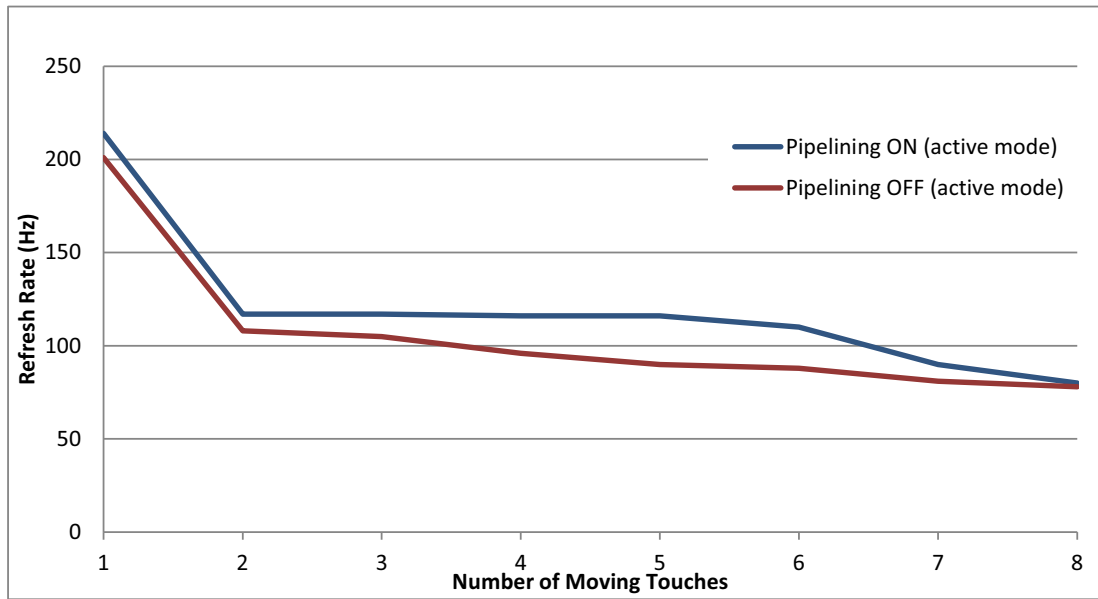

13.8.2 Touch Latency

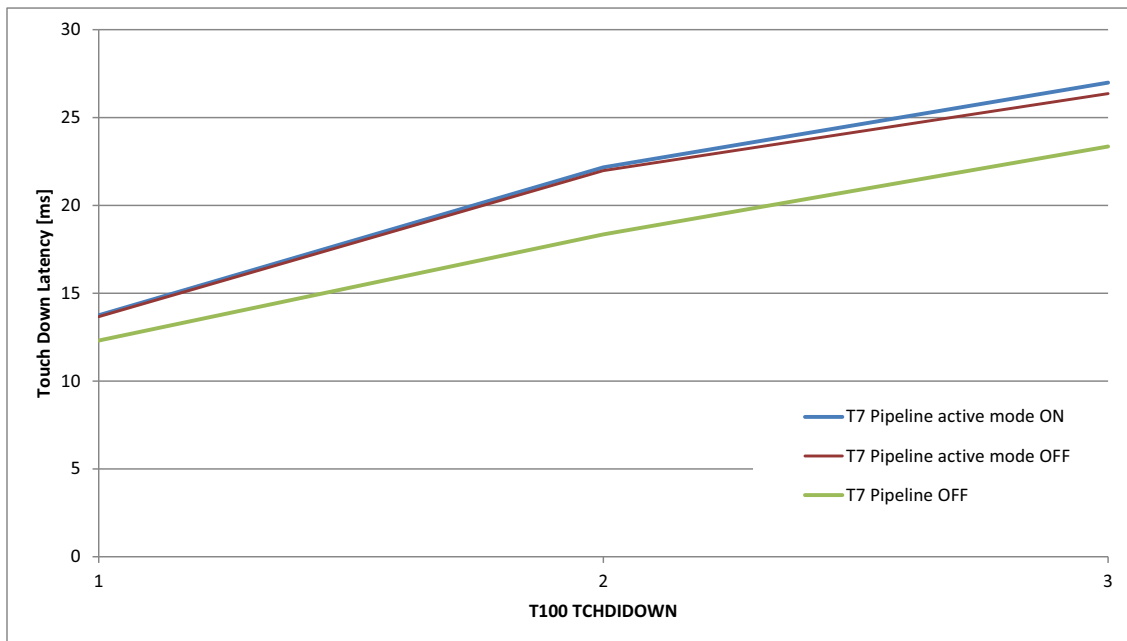

13.8.3 Reset Timing

Parameter	Min	Typ	Max	Units	Notes
Power on to $\overline{\text{CHG}}$ line low	-	81	-	ms	Vdd supply for POR VddIO supply for external reset
Hardware reset to $\overline{\text{CHG}}$ line low	-	80	-	ms	
Software reset to $\overline{\text{CHG}}$ line low	-	100	-	ms	

- Any $\overline{\text{CHG}}$ line activity before the power-on or reset period has expired should be ignored by the host. Operation of this signal cannot be guaranteed before the power-on/reset periods have expired.
- The mXT336T meets Microsoft Windows 8 requirements.

13.9 Input/Output Characteristics

Parameter	Description	Min	Typ	Max	Units	Notes
Input ($\overline{\text{RESET}}$, GPIO, SDA, SCL)						
Vil	Low input logic level	-0.3	-	$0.3 \times \text{VddIO}$	V	VddIO = 1.8 V to Vdd
Vih	High input logic level	$0.7 \times \text{VddIO}$	-	VddIO	V	VddIO = 1.8 V to Vdd
Iil	Input leakage current	-	-	1	μA	Pull-up resistors disabled
$\overline{\text{RESET}}$ pin	Internal pull-up resistor	20	40	60	$\text{k}\Omega$	
Output ($\overline{\text{CHG}}$, GPIO, SDA, SCL)						
Vol	Low output voltage	0	-	$0.2 \times \text{VddIO}$	V	VDDIO = 1.8 V to VDD. Iol = -2 mA
Voh	High output voltage	$0.8 \times \text{VddIO}$	-	VddIO	V	VDDIO = 1.8 V to VDD. Ioh = 2 mA

13.10 I²C Specifications

Parameter	Value
Addresses	0x4A
Maximum bus speed (SCL)	3.4 MHz
I ² C specification	Version 6.0
Required pull-up resistance for standard mode (100 kHz)	1 k Ω to 10 k Ω ⁽¹⁾
Required pull-up resistance for fast mode (400 kHz)	1 k Ω to 3 k Ω ⁽¹⁾
Required pull-up resistance for fast+ mode (1 MHz)	0.7 k Ω (max) ⁽¹⁾
Required pull-up resistance for high-speed mode (3.4 MHz)	0.5 k Ω to 0.75 k Ω ⁽¹⁾

- Notes:
- The values of pull-up resistors should be chosen to ensure SCL and SDA rise and fall times meet the I²C specification. The value required will depend on the amount of stray capacitance on the line.
 - In systems with heavily laden I²C lines, bus speed may be limited by loading and minimum pull-up resistor values.

More detailed information on I²C operation is available from www.nxp.com/documents/user_manual/UM10204.pdf.

13.11 Touch Accuracy and Repeatability

Parameter	Min	Typ	Max	Units	Notes
Linearity (touch only; 5.4 mm electrode pitch)	–	±1	–	mm	8 mm or greater finger
Linearity (touch only; 4.2 mm electrode pitch)	–	±0.5	–	mm	4 mm or greater finger
Accuracy	–	±1	–	mm	
Accuracy at edge	–	±2	–	mm	
Repeatability	–	±0.25	–	%	X axis with 12-bit resolution

13.12 Thermal Packaging

13.12.1 Thermal Data

Parameter	Typ	Unit	Condition	Package
Junction to ambient thermal resistance	46.5	°C/W	Still air	UFBGA 64, 5 × 5 mm
Junction to case thermal resistance	7.3	°C/W		UFBGA 64, 5 × 5 mm
Junction to ambient thermal resistance	48.4	°C/W	Still air	UFBGA 72, 6 × 6 mm
Junction to case thermal resistance	5.3	°C/W		UFBGA 72, 6 × 6 mm
Junction to ambient thermal resistance	22.4	°C/W	Still air	UFQFN 56, 6 × 6 mm
Junction to case thermal resistance	5.2	°C/W	–	UFQFN 56, 6 × 6 mm

13.12.2 Junction Temperature

The average chip junction temperature, T_J in °C can be obtained from the following:

$$T_J = T_A + (P_D \times \theta_{JA})$$

If a cooling device is required, use this equation:

$$T_J = T_A + (P_D \times (\theta_{HEATSINK} + \theta_{JC}))$$

where:

- θ_{JA} = package thermal resistance, Junction to ambient (°C/W).
- θ_{JC} = package thermal resistance, Junction to case thermal resistance (°C/W).
- $\theta_{HEATSINK}$ = cooling device thermal resistance (°C/W), provided in the cooling device datasheet.
- P_D = device power consumption (W).
- T_A is the ambient temperature (°C).

13.13 ESD Information

Parameter	Value	Reference standard
Human Body Model (HBM)	±2000 V	JEDEC JS-001
Charge Device Model (CDM)	±250 V	

13.14 Soldering Profile

Profile Feature	Green Package
Average Ramp-up Rate (217°C to Peak)	3°C/s max
Preheat Temperature 175°C ±25°C	150 – 200°C
Time Maintained Above 217°C	60 – 150 s
Time within 5°C of Actual Peak Temperature	30 s
Peak Temperature Range	260°C
Ramp down Rate	6°C/s max
Time 25°C to Peak Temperature	8 minutes max

13.15 Moisture Sensitivity Level (MSL)

MSL Rating	Package Type(s)	Peak Body Temperature	Specifications
MSL1	UQFN	260°C	IPC/JEDEC J-STD-020
MSL3	BGA	260°C	IPC/JEDEC J-STD-020

14. Package Information

14.1 Part Marking

14.1.1 56-Pin UFQFN Package

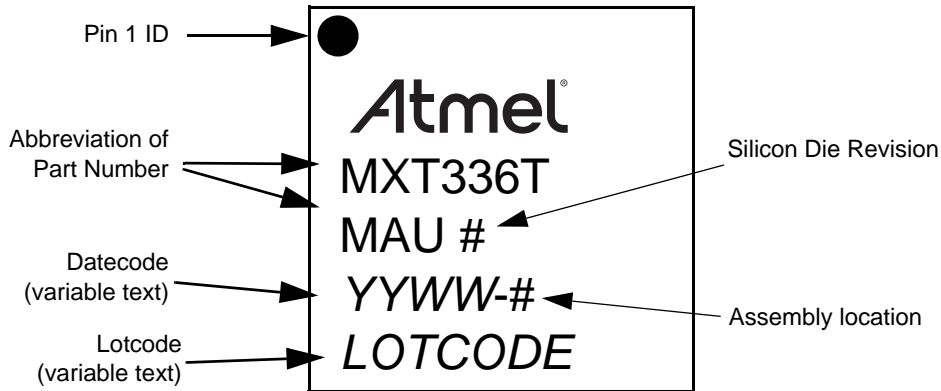

14.1.2 64-Ball UFBGA Package

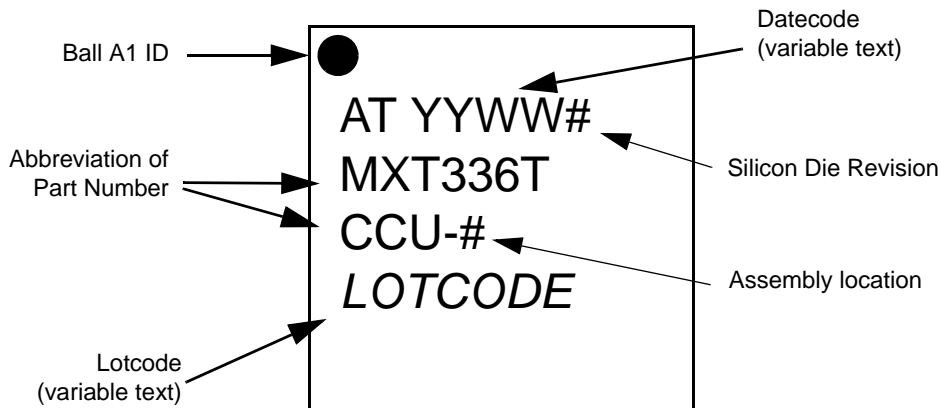

14.1.3 72-Ball UFBGA Package

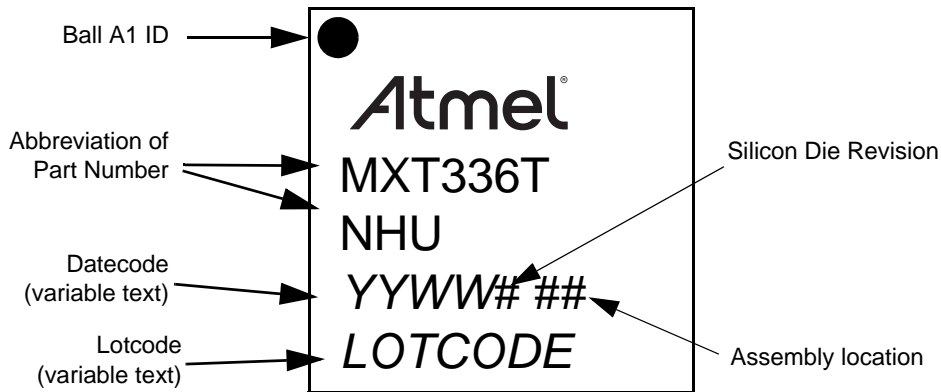

14.2 Orderable Part Numbers

Orderable Part Number	SL Code ⁽¹⁾	Firmware Revision	Description
ATMXT336T-MAU (trays)	Q1114	2.3	56-pin UQFN 6 × 6 × 0.6 mm, 0.35 mm pin pitch, RoHS compliant
ATMXT336T-MAUR (tape and reels)	Q1114	2.3	56-pin UQFN 6 × 6 × 0.6 mm, 0.35 mm pin pitch, RoHS compliant
ATMXT336T-CCU (trays)	Q1114	2.3	64-ball UFBGA 5 × 5 × 0.6 mm, 0.5 mm ball pitch, RoHS compliant
ATMXT336T-CCUR (tape and reels)	Q1114	2.3	64-ball UFBGA 5 × 5 × 0.6 mm, 0.5 mm ball pitch, RoHS compliant
ATMXT336T-NHU (trays)	Q1114	2.3	72-ball UFBGA 6 × 6 × 0.6 mm, 0.5 mm ball pitch, RoHS compliant
ATMXT336T-NHUR (tape and reels)	Q1114	2.3	72-ball UFBGA 6 × 6 × 0.6 mm, 0.5 mm ball pitch, RoHS compliant

Notes: 1. All purchase orders must include the Orderable Part Number and the SL Code. (Note: SL Code was formerly known as QS Number.)

14.3 Mechanical Drawings

14.3.1 UFQFN 56 Pins

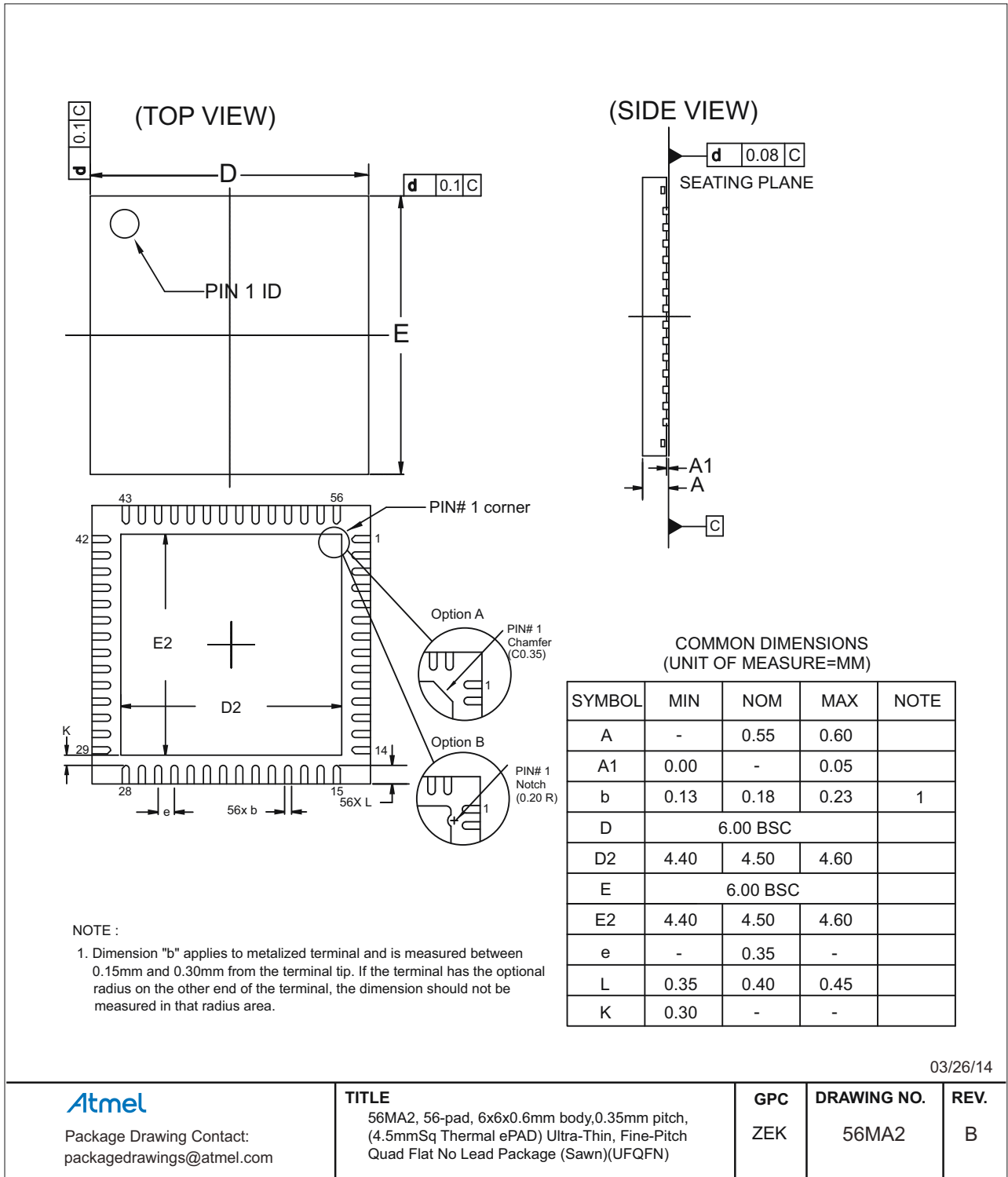

14.3.2 UFBGA 64 Balls

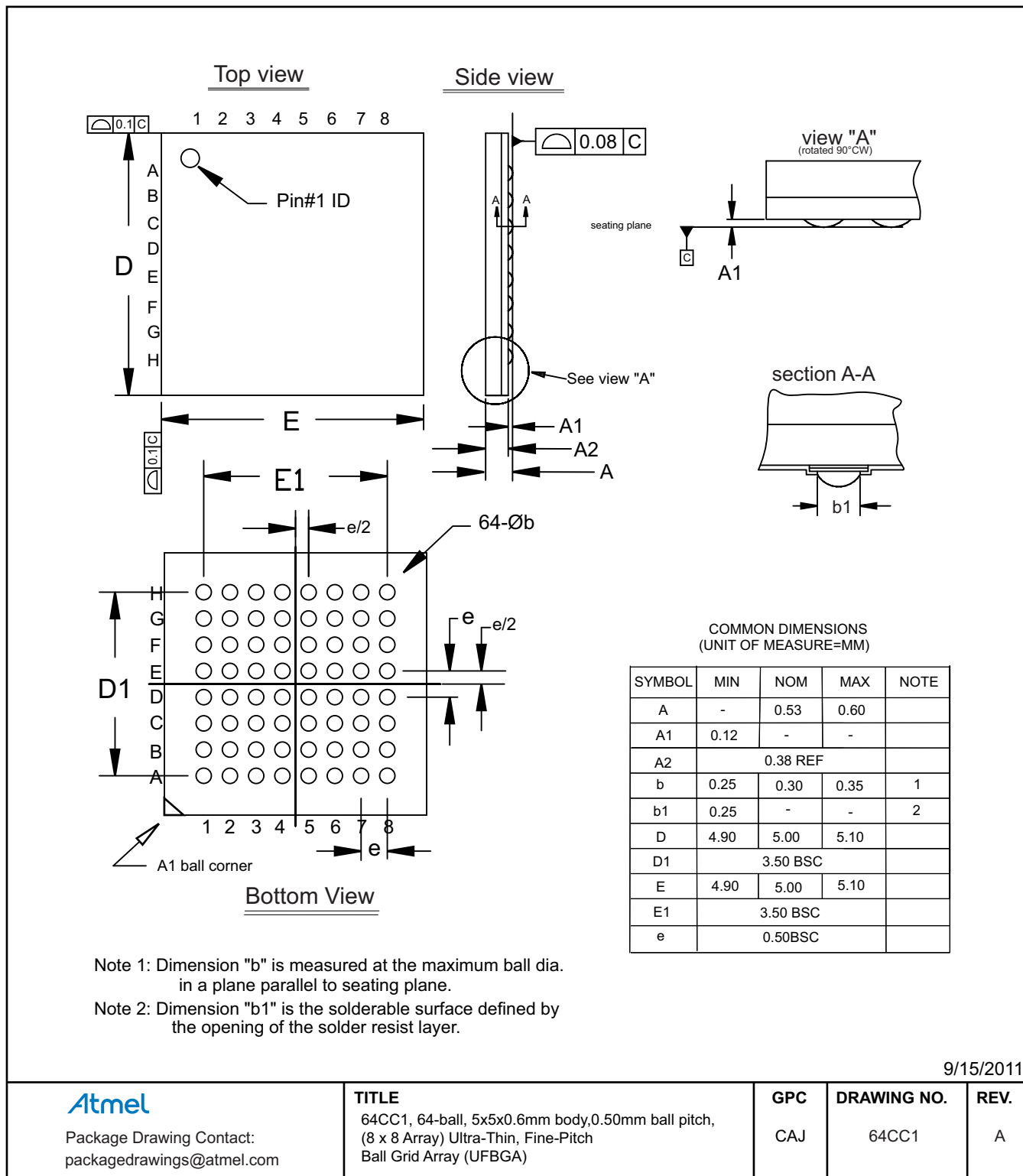

Package Drawing Contact:
packagedrawings@atmel.com

TITLE

64CC1, 64-ball, 5x5x0.6mm body, 0.50mm ball pitch,
(8 x 8 Array) Ultra-Thin, Fine-Pitch
Ball Grid Array (UFBGA)

GPC

CAJ

DRAWING NO.

64CC1

REV.

A

14.3.3 UFBGA 72 Balls

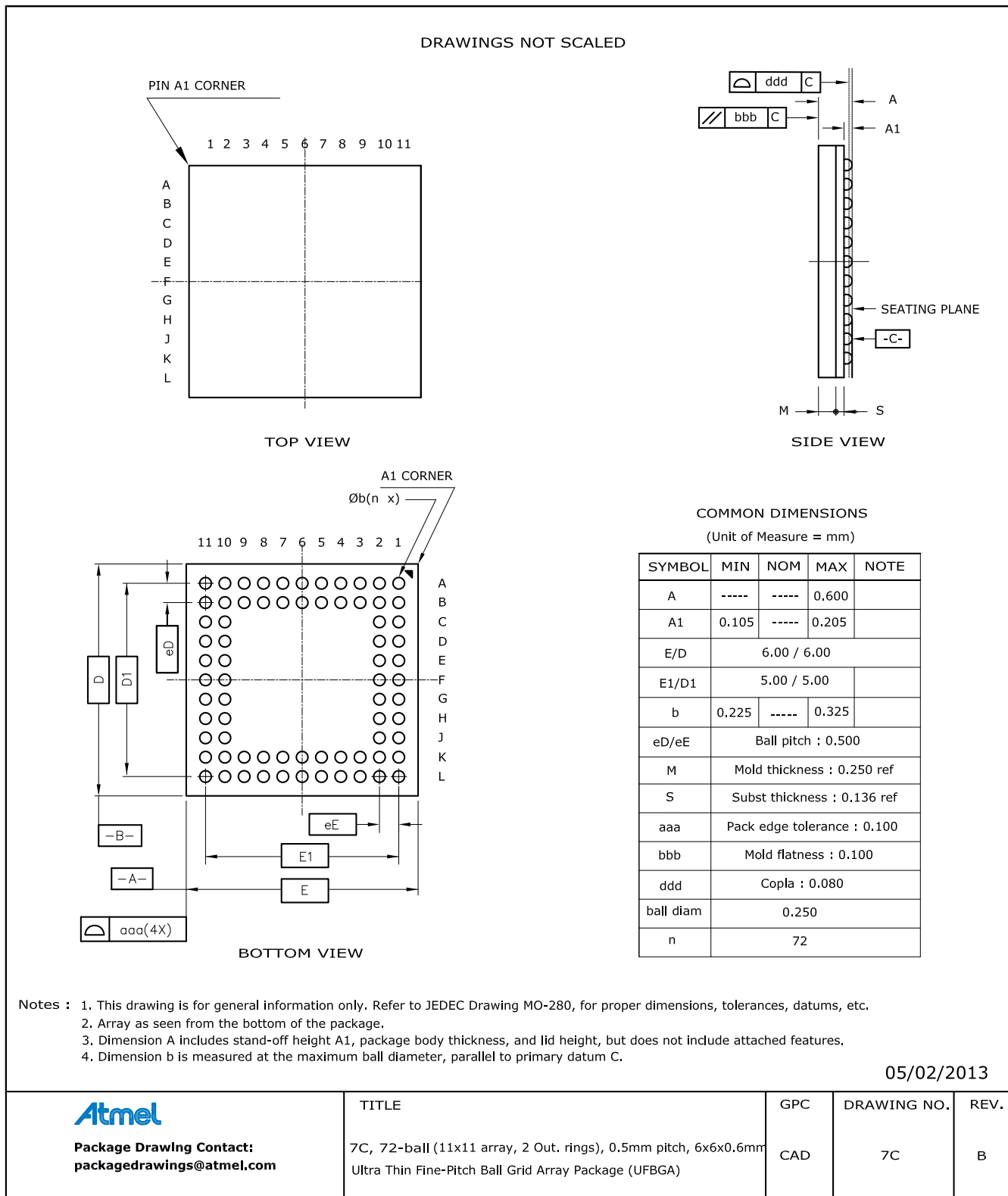

Associated Documents

The following documents may be useful (available by contacting Atmel Touch Technology Division):

Note: The documents listed below are available under NDA only. In addition, some documents may have further restrictions placed upon them.

For information on using and configuring the device, see the following:

- *maXTouch T Series Tuning Guide* (distributed with Atmel approval only)
- *mXT336T 2.3 Protocol Guide* (distributed with Atmel approval only)

The following documents may also be useful:

- **Touchscreen design and PCB/FPCB layout guidelines:**
 - Application Note: QTAN0054 – *Getting Started with maXTouch Touchscreen Designs*
 - Application Note: MXTAN0208 – *Design Guide for PCB Layouts for Atmel Touch Controllers*
 - Application Note: QTAN0080 – *Touchscreens Sensor Design Guide*
- **Configuring the device:**
 - Application Note: QTAN0059 – *Using the maXTouch Self Test Feature*
 - Application Note: MXT0202 – *Using the Unlock Gesture T81 Object*
 - Application Note: MXTAN0207 – *PTC Quick Reference and Tuning*
- **Miscellaneous:**
 - Application Note: QTAN0050 – *Using the maXTouch Debug Port*
 - Application Note: QTAN0058 – *Rejecting Unintentional Touches with the maXTouch Touchscreen Controllers*
 - Application Note: QTAN0061 – *maXTouch Sensitivity Effects for Mobile Devices*
 - Application Note: QTAN0051 – *Bootloading Procedure for Atmel Touch Sensors Based on the Object Protocol*
- **Tools:**
 - *maXTouch Studio User Guide* (distributed as on-line help with maXTouch Studio)

Revision History

Revision Number	History
Revision AX – September 2015	Initial edition for firmware revision 2.3 – Release
Revision BX – October 2016	<ul style="list-style-type: none">• Pinout information for DS0 corrected. Now says leave open if unused



Enabling Unlimited Possibilities®

Atmel Corporation

1600 Technology Drive
San Jose, CA 95110
USA

Tel: (+1) (408) 441-0311

Fax: (+1) (408) 487-2600

www.atmel.com

Atmel Asia Limited

Unit 01-5 & 16, 19F
BEA Tower, Millennium City 5
418 Kwun Tong Road

Kwun Tong, Kowloon

HONG KONG

Tel: (+852) 2245-6100

Fax: (+852) 2722-1369

Atmel München GmbH

Business Campus
Parkring 4
D-85748 Garching bei München

GERMANY

Tel: (+49) 89-31970-0

Fax: (+49) 89-3194621

Atmel Japan G.K.

16F Shin-Osaki Kangyo Bldg
1-6-4 Osaki, Shinagawa-ku
Tokyo 141-0032

JAPAN

Tel: (+81) (3) 6417-0300

Fax: (+81) (3) 6417-0370

© 2015 – 2016 Atmel Corporation. All rights reserved.

Atmel®, Atmel logo and combinations thereof, Enabling Unlimited Possibilities®, maXTouch®, QMatrix® and others are registered trademarks or trademarks of Atmel Corporation or its subsidiaries. Microsoft® and Windows® are registered trademarks of Microsoft Corporation in the United States and other countries. Other terms and product names may be trademarks of others.

Disclaimer: The information in this document is provided in connection with Atmel products. No license, express or implied, by estoppel or otherwise, to any intellectual property right is granted by this document or in connection with the sale of Atmel products. EXCEPT AS SET FORTH IN THE ATMEL TERMS AND CONDITIONS OF SALES LOCATED ON THE ATMEL WEBSITE, ATMEL ASSUMES NO LIABILITY WHATSOEVER AND DISCLAIMS ANY EXPRESS, IMPLIED OR STATUTORY WARRANTY RELATING TO ITS PRODUCTS INCLUDING, BUT NOT LIMITED TO, THE IMPLIED WARRANTY OF MERCHANTABILITY, FITNESS FOR A PARTICULAR PURPOSE, OR NON-INFRINGEMENT. IN NO EVENT SHALL ATMEL BE LIABLE FOR ANY DIRECT, INDIRECT, CONSEQUENTIAL, PUNITIVE, SPECIAL OR INCIDENTAL DAMAGES (INCLUDING, WITHOUT LIMITATION, DAMAGES FOR LOSS AND PROFITS, BUSINESS INTERRUPTION, OR LOSS OF INFORMATION) ARISING OUT OF THE USE OR INABILITY TO USE THIS DOCUMENT, EVEN IF ATMEL HAS BEEN ADVISED OF THE POSSIBILITY OF SUCH DAMAGES. Atmel makes no representations or warranties with respect to the accuracy or completeness of the contents of this document and reserves the right to make changes to specifications and products descriptions at any time without notice. Atmel does not make any commitment to update the information contained herein. Atmel products are not intended, authorized, or warranted for use as components in applications intended to support or sustain life.