

April 1995

30A, 700V - 1000V Ultrafast Diodes

Features

- Ultrafast with Soft Recovery Characteristic ($t_{RR} < 110\text{ns}$)
- +175°C Rated Junction Temperature
- Reverse Voltage Up to 1000V
- Avalanche Energy Rated
- Planar Construction

Applications

- Switching Power Supply
- Power Switching Circuits
- General Purpose

Description

RURP3070, RURP3080, RURP3090, RURP30100 are ultrafast diodes with soft recovery characteristics ($t_{RR} < 110\text{ns}$). They have a low forward voltage drop and are silicon nitride passivated, ion-implanted, epitaxial construction.

These devices are intended for use as flywheel/clamping diodes and rectifiers in a variety of switching power supplies and other power switching applications. Their low stored charge and ultrafast recovery with soft recovery characteristics minimizes ringing and electrical noise in many power switching circuits thus reducing power loss in the switching transistor.

PACKAGING AVAILABILITY

PART NUMBER	PACKAGE	BRAND
RURP3070	TO-220AC	RURP3070
RURP3080	TO-220AC	RURP3080
RURP3090	TO-220AC	RURP3090
RURP30100	TO-220AC	RUR30100

NOTE: When ordering, use the entire part number.

Package

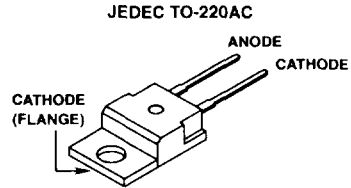

Symbol



Absolute Maximum Ratings $T_C = +25^\circ\text{C}$, Unless Otherwise Specified

	RURP3070	RURP3080	RURP3090	RURP30100
Peak Repetitive Reverse Voltage..... V_{RRM}	700V	800V	900V	1000V
Working Peak Reverse Voltage..... V_{RWM}	700V	800V	900V	1000V
DC Blocking Voltage..... V_R	700V	800V	900V	1000V
Average Rectified Forward Current..... $I_{F(AV)}$ ($T_C = +121^\circ\text{C}$)	30A	30A	30A	30A
Peak Forward Repetitive Current..... I_{FRM} (Square wave 20kHz)	60A	60A	60A	60A
Nonrepetitive Peak Surge Current..... I_{FSM} (Surge applied at rated load condition halfwave 1 phase 60Hz)	300A	300A	300A	300A
Maximum Power Dissipation..... P_D	125W	125W	125W	125W
Operating and Storage Temperature..... T_{STG}, T_J	-65°C to +175°C	-65°C to +175°C	-65°C to +175°C	-65°C to +175°C

Specifications RURP3070, RURP3080, RURP3090, RURP30100

Electrical Specifications $T_C = +25^\circ\text{C}$, Unless Otherwise Specified.

SYMBOL	TEST CONDITION	LIMITS												UNITS
		RURP3070			RURP3080			RURP3090			RURP30100			
		MIN	TYP	MAX	MIN	TYP	MAX	MIN	TYP	MAX	MIN	TYP	MAX	
V_F	$I_F = 30\text{A}$ $T_C = +150^\circ\text{C}$	-	-	1.60	-	-	1.60	-	-	1.60	-	-	1.60	V
	$I_F = 30\text{A}$ $T_C = +25^\circ\text{C}$	-	-	1.80	-	-	1.80	-	-	1.80	-	-	1.80	V
I_R at $T_C = +150^\circ\text{C}$	$V_R = 700\text{V}$	-	-	1	-	-	-	-	-	-	-	-	-	mA
	$V_R = 800\text{V}$	-	-	-	-	-	1	-	-	-	-	-	-	mA
	$V_R = 900\text{V}$	-	-	-	-	-	-	-	1	-	-	-	-	mA
	$V_R = 1000\text{V}$	-	-	-	-	-	-	-	-	-	-	1	-	mA
I_R at $T_C = +25^\circ\text{C}$	$V_R = 700\text{V}$	-	-	500	-	-	-	-	-	-	-	-	-	μA
	$V_R = 800\text{V}$	-	-	-	-	-	500	-	-	-	-	-	-	μA
	$V_R = 900\text{V}$	-	-	-	-	-	-	-	500	-	-	-	-	μA
	$V_R = 1000\text{V}$	-	-	-	-	-	-	-	-	-	-	500	-	μA
t_{RR}	$I_F = 1\text{A}$	-	-	110	-	-	110	-	-	110	-	-	110	ns
	$I_F = 30\text{A}$	-	-	150	-	-	150	-	-	150	-	-	150	ns
t_A	$I_F = 30\text{A}$	-	90	-	-	90	-	-	90	-	-	90	-	ns
t_B	$I_F = 30\text{A}$	-	45	-	-	45	-	-	45	-	-	45	-	ns
R_{JWC}		-	-	1.2	-	-	1.2	-	-	1.2	-	-	1.2	$^\circ\text{C/W}$
E_{AVL}		-	-	20	-	-	20	-	-	20	-	-	20	mJ

DEFINITIONS

V_F = Instantaneous forward voltage ($p_w = 300\mu\text{s}$, $D = 2\%$).

I_R = Instantaneous reverse current.

t_{RR} = Reverse recovery time at $di_F/dt = 100\text{A}/\mu\text{s}$ (See Figure 2), summation of $t_A + t_B$.

t_A = Time to reach peak reverse current at $di_F/dt = 100\text{A}/\mu\text{s}$ (See Figure 2).

t_B = Time from peak I_{RM} to projected zero crossing of I_{RM} based on a straight line from peak I_{RM} through 25% of I_{RM} (See Figure 2).

R_{JWC} = Thermal resistance junction to case.

E_{AVL} = Controlled avalanche energy (See Figures 7 and 8).

p_w = pulse width.

D = duty cycle.

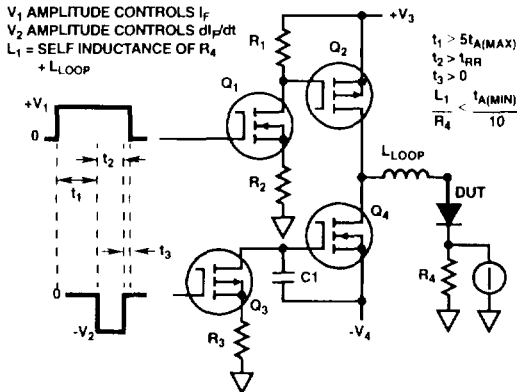

FIGURE 1. t_{RR} TEST CIRCUIT

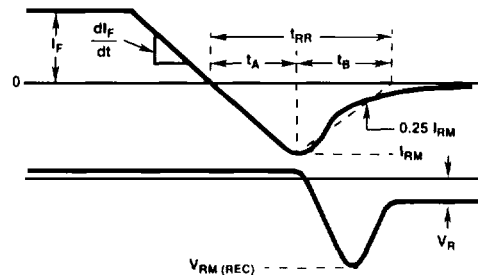

FIGURE 2. DEFINITIONS OF t_{RR} , t_A AND t_B

Typical Performance Curves

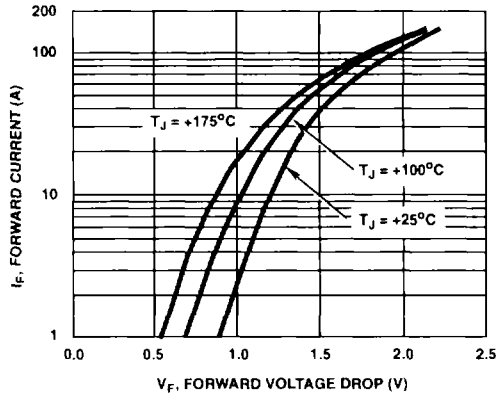

FIGURE 3. TYPICAL FORWARD CURRENT vs FORWARD VOLTAGE DROP

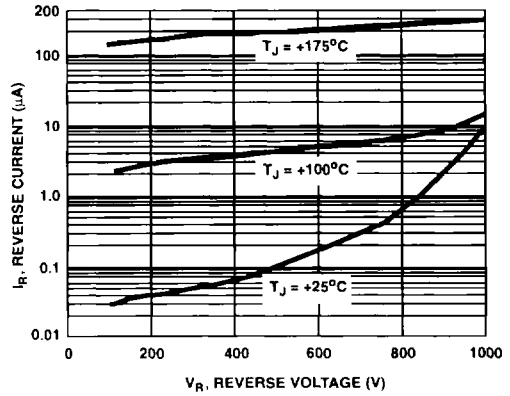

FIGURE 4. REVERSE VOLTAGE vs REVERSE CURRENT CHARACTERISTIC

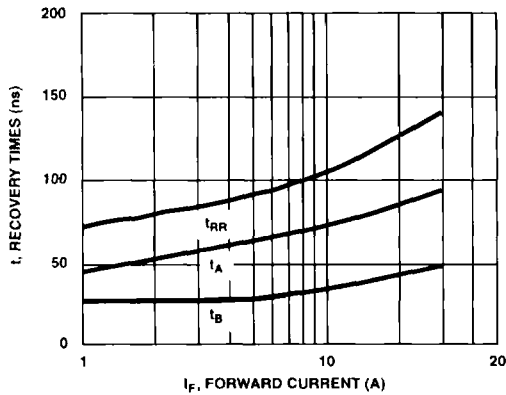

FIGURE 5. TYPICAL t_{RR} , t_A AND t_B CURVES vs FORWARD CURRENT

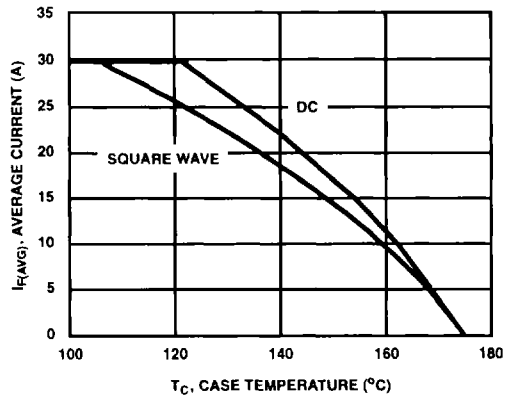

FIGURE 6. TYPICAL CURRENT DERATING CURVE vs CASE TEMPERATURE

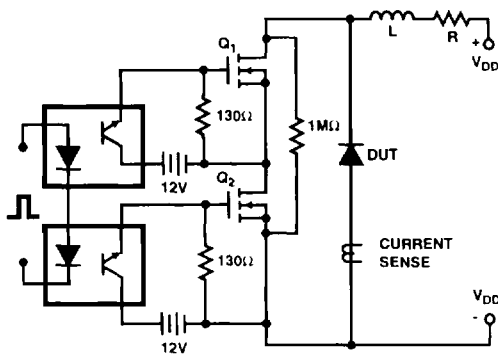

FIGURE 7. AVALANCHE ENERGY TEST CIRCUIT

$$I_{L,peak} = 1A, L = 40mH, R < 0.1\Omega, E_{AVL} = \left(\frac{1}{2}\right) L I^2 [V_{AVL}/(V_{AVL} - V_{DD})]$$

Q1 AND Q2 ARE 1000V MOSFETS

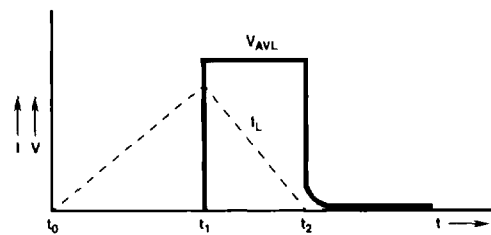

FIGURE 8. CURRENT VOLTAGE WAVEFORM

5
ULTRAFAST
SINGLE DIODES