



Optimized Reconfigurable Cell Array (ORCA) ATT2Cxx Series Field-Programmable Gate Arrays

Features

- High-performance, cost-effective 0.5 μm technology (four-input look-up table delay less than 3.6 ns)
- High density (up to 43,200 usable, logic-only gates, or 99,400 gates including RAM)
- Up to 480 user I/Os
- Fast on-chip user SRAM: 64 bits/logic block
- Nibble-oriented architecture for implementing 4-, 8-, 16-, 32-bit (or wider) bus structures
- Innovative, abundant, and hierarchical nibble-oriented routing resources that allow automatic use of internal gates for all device densities without sacrificing performance
- Four 16-bit look-up tables and four latches/flip-flops per logic block
- Internal fast carry for arithmetic functions
- TTL or CMOS input thresholds programmable per pin
- Individually programmable drive capability: 12 mA sink/6 mA source or 6 mA sink/3 mA source
- Built-in boundary scan (IEEE 1149.1)
- Low power consumption from submicron CMOS process
- Full PCI-bus compliance
- Supported by industry-standard CAE tools for design entry, synthesis, and simulation
- ORCA Foundry Development System support

Description

The Lucent Technologies Optimized Reconfigurable Cell Array (ORCA) series is the second generation of SRAM-based field-programmable gate arrays (FPGAs) from Lucent. The ORCA 2C FPGA series provides seven CMOS FPGAs ranging in complexity from 4,800 to 43,200 usable gates in a variety of packages, speed grades, and temperature ranges. Table 1 lists the usable gates for the 0.5 μm ORCA 2C series FPGAs.

The ORCA series FPGA consists of two basic elements: programmable logic cells (PLCs) and programmable input/output cells (PICs). An array of PLCs is surrounded by PICs. Each PLC contains a programmable function unit (PFU). The PLCs and PICs also contain routing resources and configuration RAM. All logic is done in the PFU. Each PFU contains four 16-bit look-up tables (LUTs) and four latches/flip-flops (FFs).

The PLC architecture provides a balanced mix of logic and routing which allows a higher utilized gate/PFU than alternative architectures. The routing resources carry logic signals between PFUs and I/O pads. The routing in the PLC is symmetrical about the horizontal and vertical axes. This improves routability by allowing a signal to be routed into the PLC from any direction.

Table 1. ORCA 2C Series FPGAs

Device	Usable Gates*	Latches/ Flip-Flops	Max User RAM Bits	User I/Os	Array Size
2C04	4,800—11,000	400	6,400	160	10 x 10
2C06	6,900—15,900	576	9,216	192	12 x 12
2C08	9,400—21,600	784	12,544	224	14 x 14
2C10	12,300—28,300	1024	16,384	256	16 x 16
2C12	15,600—35,800	1296	20,736	288	18 x 18
2C15	19,200—44,200	1600	25,600	320	20 x 20
2C26	27,600—63,600	2304	36,864	384	24 x 24
2C40	43,200—99,400	3600	57,600	480	30 x 30

* The first number in the usable gates column assumes 48 gates per PFU for logic-only designs. The second number assumes 30% of a design is RAM. PFUs used as RAM are counted at 4 gates per bit, with each PFU capable of implementing a 16 x 4 RAM (or 256 gates) per PFU.

Table of Contents

Contents	Page	Contents	Page
Features	2-169	Configuration Data Format	2-204
Description	2-169	Using <i>ORCA</i> Foundry to Generate	
<i>ORCA</i> Foundry Development System		Configuration RAM Data	2-204
Overview	2-171	Configuration Data Frame	2-204
Architecture	2-172	Bit Stream Error Checking	2-207
Programmable Logic Cells	2-172	FPGA Configuration Modes	2-207
Programmable Function Unit	2-172	Master Parallel Mode	2-207
Look-Up Table Operating Modes	2-174	Master Serial Mode	2-208
Latches/Flip-Flops	2-178	Asynchronous Peripheral Mode	2-209
PLC Routing Resources	2-179	Synchronous Peripheral Mode	2-209
PLC Architectural Description	2-184	Slave Serial Mode	2-210
Programmable Input/Output Cells	2-187	Slave Parallel Mode	2-210
Inputs	2-187	Daisy Chain	2-211
Outputs	2-188	Readback	2-212
PIC Routing Resources	2-188	Boundary Scan	2-213
PIC Architectural Description	2-190	Boundary-Scan Instructions	2-214
PLC-PIC Routing Resources	2-192	<i>ORCA</i> Boundary-Scan Circuitry	2-215
Interquad Routing	2-193	<i>ORCA</i> Timing Characteristics	2-218
ATT2C40 Subquad Routing	2-195	Estimating Power Dissipation	2-220
PIC Interquad (MID) Routing	2-197	Pin Information	2-222
Programmable Corner Cells	2-198	Package Compatibility	2-224
Programmable Routing	2-198	Package Thermal Characteristics	2-267
Special-Purpose Functions	2-198	Package Coplanarity	2-268
Clock Distribution Network	2-198	Package Parasitics	2-268
Primary Clock	2-198	Absolute Maximum Ratings	2-270
Secondary Clock	2-199	Recommended Operating Conditions	2-270
FPGA States of Operation	2-201	Electrical Characteristics	2-271
Initialization	2-201	Timing Characteristics	2-272
Configuration	2-202	Measurement Conditions	2-289
Start-Up	2-202	Output Buffer Characteristics	2-290
Reconfiguration	2-203	Ordering Information	2-291

Description (continued)

The ORCA Foundry Development System is used to process a design from a netlist to a configured FPGA. Lucent provides interfaces and libraries to popular CAE tools for design entry and simulation.

The FPGA's functionality is determined by internal configuration RAM. The FPGA's internal initialization/configuration circuitry loads the configuration data at powerup or under system control. The RAM is loaded by using one of several configuration modes. The configuration data resides externally in an EEPROM, EPROM, or ROM on the circuit board, or any other storage media. Serial ROMs provide a simple, low pin count method for configuring FPGAs.

ORCA Foundry Development System Overview

The ORCA Foundry Development System interfaces to front-end design entry tools and provides the tools to produce a configured FPGA. In the design flow, the user defines the functionality of the FPGA at two points in the design flow: at design entry and at the bit stream generation stage.

Following design entry, the development system's map, place, and route tools translate the netlist into a routed FPGA. Its bit stream generator is then used to generate the configuration data which is loaded into the FPGA's internal configuration RAM. When using the bit stream generator, the user selects options that affect the functionality of the FPGA. Combined with the front-end tools, ORCA Foundry produces configuration data that implements the various logic and routing options discussed in this data sheet.

2

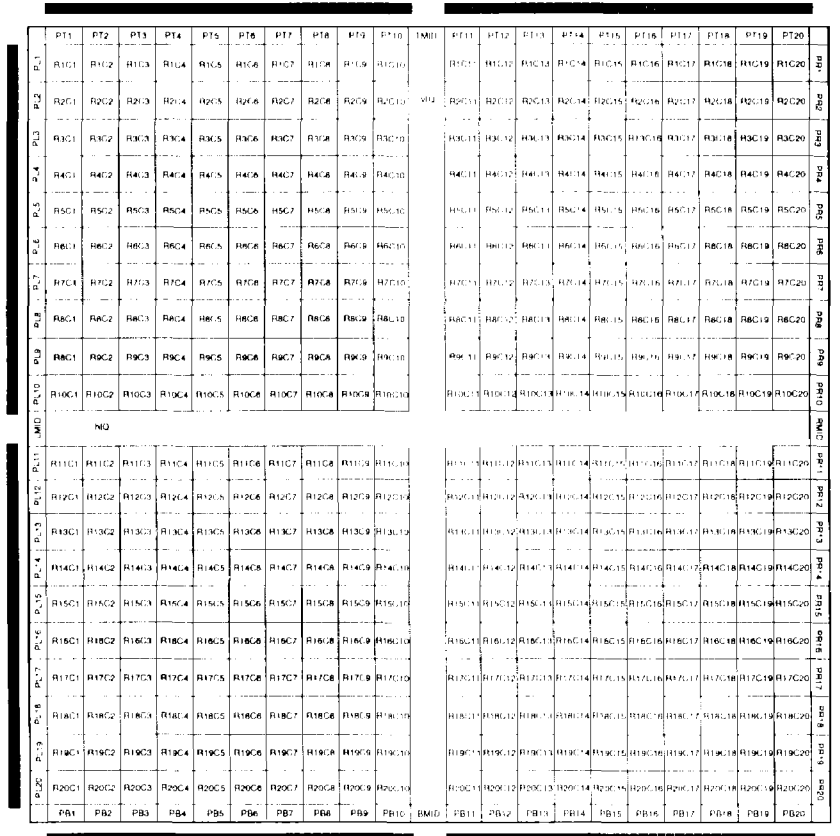

5 4489(C)

Figure 1. ATT2C15 Array

Architecture

2

The ORCA Series FPGA is comprised of two basic elements: PLCs and PICs. Figure 1 shows an array of programmable logic cells (PLCs) surrounded by programmable input/output cells (PICs). The ATT2C15 has PLCs arranged in an array of 20 rows and 20 columns. PICs are located on all four sides of the FPGA between the PLCs and the IC edge. The location of a PLC is indicated by its row and column so that a PLC in the second row and third column is R2C3. PICs are indicated similarly, with PT (top) and PB (bottom) designating rows and PL (left) and PR (right) designating columns, followed by a number. The routing resources and configuration RAM are not shown, but the interquad routing blocks (hIQ, vIQ) present in the 2C series are shown.

Each PIC contains the necessary I/O buffers to interface to bond pads. The PICs also contain the routing resources needed to connect signals from the bond pads to/from PLCs. The PICs do not contain any user-accessible logic elements, such as flip-flops.

Combinatorial logic is done in look-up tables (LUTs) located in the PFU. The PFU can be used in different modes to meet different logic requirements. The LUT's configurable medium-/large-grain architecture can be used to implement from one to four combinatorial logic functions. The flexibility of the LUT to handle wide input functions as well as multiple smaller input functions maximizes the gate count/PFU.

Programmable Logic Cells

The programmable logic cell (PLC) consists of a programmable function unit (PFU) and routing resources. All PLCs in the array are identical. The PFU, which contains four LUTs and four latches/FFs for logic implementation, is discussed in the next section.

Programmable Function Unit

The programmable function units (PFUs) are used for logic. The PFU has 19 external inputs and six outputs and can operate in several modes. The functionality of the inputs and outputs depends on the operating mode.

The PFU uses three input data buses (a[4:0], b[4:0], wd[3:0]), four control inputs (c0, ck, ce, lsr), and a carry input (cin); the last is used for fast arithmetic functions. There is a 5-bit output bus (o[4:0]) and a carry-out (cout).

Figure 2 and Figure 3 show high-level and detailed views of the ports in the PFU, respectively. The ports are referenced with a two- to four-character suffix to a PFU's location. As mentioned, there are two 5-bit input data buses (a[4:0] and b[4:0]) to the LUT, one 4-bit input data bus (wd[3:0]) to the latches/FFs, and an output data bus (o[4:0]).

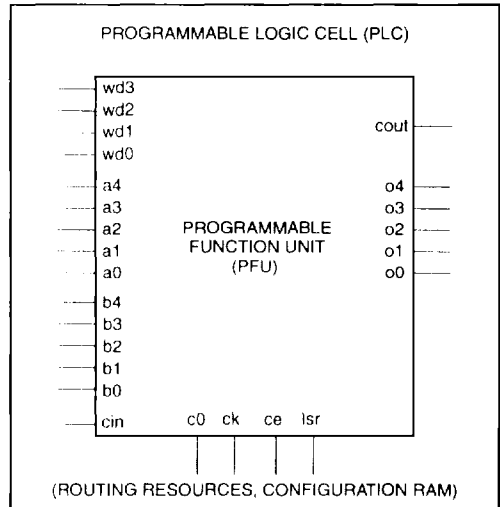

5-2750(F)

Figure 2. PFU Ports

The PFU is used in a variety of modes, as illustrated in Figures 4 through 11, and it is these specific modes that are most relevant to PFU functionality.

The PFU does combinatorial logic in the LUT and sequential logic in the latches/FFs. The LUT is static random access memory (SRAM) and can be used for read/write or read-only memory. Table 2 lists the basic operating modes of the LUT. The operating mode affects the functionality of the PFU input and output ports and internal PFU routing.

Programmable Logic Cells (continued)

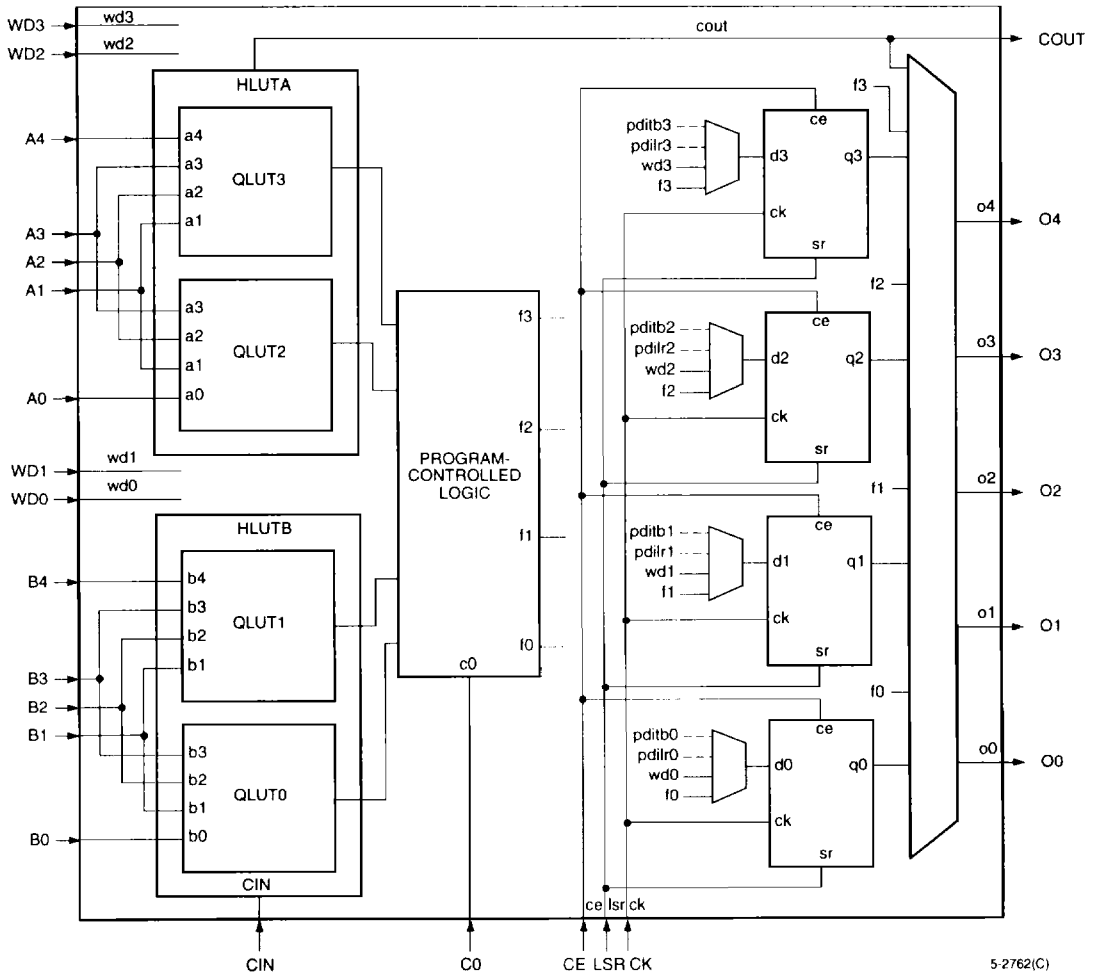

Figure 3. Simplified PFU Diagram

For example, in some operating modes, the wd[3:0] inputs are direct data inputs to the PFU latches/FFs. In the dual 16 x 2 memory mode, the same wd[3:0] inputs are used as a 4-bit data input bus into LUT memory.

Figure 3 shows the four latches/FFs and the 64-bit look-up table (LUT) in the PFU. Each latch/FF can accept data from the LUT. Alternately, the latches/FFs can accept direct data from wd[3:0], eliminating the LUT delay if no combinatorial function is needed.

The LUT outputs can bypass the latches/FFs, which reduces the delay out of the PFU. The pdilr[3:0] and pditb[3:0] inputs allow fast input from an I/O pad to the latches/FFs in the two closest PLCs perpendicular to the PIC containing the I/O pad. It is possible to use the LUT and latches/FFs more or less independently. For example, the latches/FFs can be used as a 4-bit shift register, and the LUT can be used to detect when a register has a particular pattern in it.

Programmable Logic Cells (continued)

PFU Control Inputs

The four control inputs to the PFU are clock (ck), local set/reset (l_{sr}), clock enable (ce), and c0. The ck, ce, and l_{sr} inputs control the operation of all four latches in the PFU. An active-low global set/reset (gs_{rn}) signal is also available to the latches/FFs in every PFU. Their operation is discussed briefly here, and in more detail in the Latches/Flip-Flops section. The polarity of the control inputs can be inverted.

The ck input is distributed to each PFU from a vertical or horizontal net. The ce input inhibits the latches/FFs from responding to data inputs. The ce input can be disabled, always enabling the clock. Each latch/FF can be independently programmed to be a set or reset by the l_{sr} and the global set/reset (gs_{rn}) signals. Each PFU's l_{sr} input can be configured as synchronous or asynchronous. The gs_{rn} signal is always asynchronous. The l_{sr} signal applies to all four latches/FFs in a PFU. The l_{sr} input can be disabled (the default). The asynchronous set/reset is dominant over clocked inputs.

The c0 input is used as an input in combinatorial logic functions and as a carry input. It is used as an input into special PFU logic gates in wide input functions. The c0 input can be disabled (the default).

Look-Up Table Operating Modes

The LUT can be configured to operate in one of three general modes:

- Combinatorial logic mode
- Ripple mode
- Memory mode

The combinatorial logic mode uses a 64-bit look-up table (LUT) to implement Boolean functions. The two 5-bit logic inputs, a[4:0] and b[4:0], and the c0 input are used as LUT inputs. The use of these ports changes based on the PFU operating mode.

Table 2. Look-Up Table Operating Modes

Mode	Function
F4A	Two functions of four inputs, some inputs shared (QLUT2/QLUT3)
F4B	Two functions of four inputs, some inputs shared (QLUT0/QLUT1)
F5A	One function of five inputs (HLUTA)
F5B	One function of five inputs (HLUTB)
MA	16 x 2 memory (HLUTA)
MB	16 x 2 memory (HLUTB)
R	Ripple—LUT

For combinatorial logic, the LUT can be used to do any single function of six inputs, any two functions of five inputs, or four functions of four inputs (with some inputs shared), and three special functions based on the two five-input functions and c0.

The functionality of the LUT is determined by its operating mode. The entries in Table 2 show the basic modes of operation for combinatorial logic, ripple, and memory functions in the LUT. Depending on the operating mode, the LUT can be divided into sub-LUTs. The LUT is comprised of two 32-bit half look-up tables, HLUTA and HLUTB. Each half look-up table (HLUT) is comprised of two quarter look-up tables (QLUTs). HLUTA consists of QLUT2 and QLUT3, while HLUTB consists of QLUT0 and QLUT1. The outputs of QLUT0, QLUT1, QLUT2, and QLUT3 are f0, f1, f2, and f3, respectively.

If the LUT is configured to operate in the ripple mode, it cannot be used for basic combinatorial logic or memory functions. In modes other than the ripple mode, combinations of operating modes are possible. For example, the LUT can be configured as a 16 x 2 RAM in one HLUT and a five-input combinatorial logic function in the second HLUT. This can be done by configuring HLUTA in the MA mode and HLUTB in the F5B mode (or vice versa).

F4A/F4B Mode — Two Four-Input Functions

Each HLUT can be used to implement two four-input combinatorial functions, but the total number of inputs into each HLUT cannot exceed five. The two QLUTs within each HLUT share three inputs. In HLUTA, the a1, a2, and a3 inputs are shared by QLUT2 and QLUT3. Similarly, in HLUTB, the b1, b2, and b3 inputs are shared by QLUT0 and QLUT1. The four outputs are f0, f1, f2, and f3. The use of the LUT for four functions of up to four inputs each is given in Figure 4.

Programmable Logic Cells (continued)

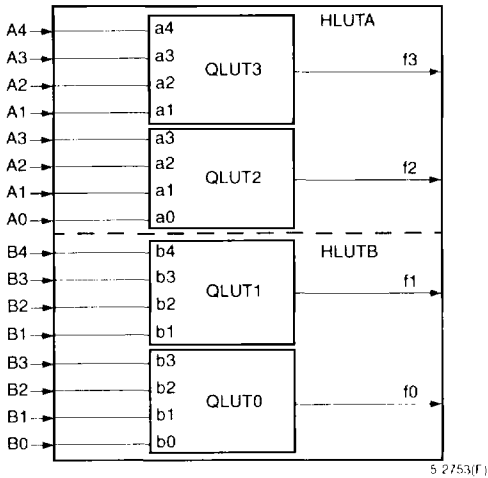

Figure 4. F4 Mode—Four Functions of Four Input Variables

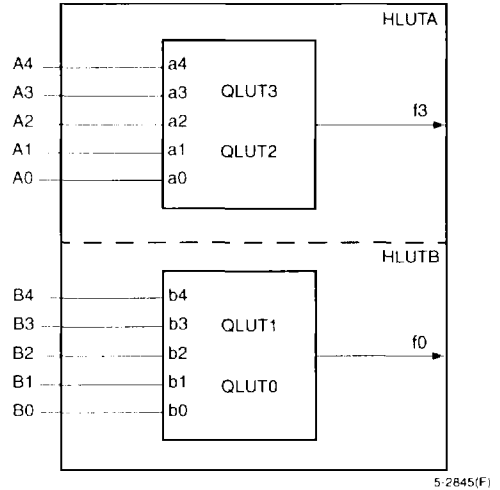

Figure 5. F5 Mode—Two Functions of Five Input Variables

F5A/F5B Mode—One Five-Input Variable Function

Each HLUT can be used to implement any five-input combinational function. The input ports are a[4:0] and b[4:0], and the output ports are f0 and f3. One five or less input function is input into a[4:0], and the second five or less input function is input into b[4:0]. The results are routed to the latch/FF d0 and latch/FF d3 inputs, or directly to the outputs o0 and o3. The use of the LUT for two independent functions of up to five inputs is given in Figure 5. In this case, the LUT is configured in the F5A and F5B modes. As a variation, the LUT can do one function of up to five input variables and two four-input functions using F5A and F4B modes or F4A and F5B modes.

F5M and F5X Modes — Special Function Modes

The PFU contains logic to implement two special function modes which are variations on the F5 mode. As with the F5 mode, the LUT implements two independent five-input functions. Figure 6 and Figure 7 show the schematics for F5M and F5X modes. The F5X and F5M functions differ from the basic F5A/F5B functions in that there are three logic gates which have inputs from the LUT. In some cases, this can be used for faster and/or wider logic functions. The HLUTs operate as in the F5 mode, providing outputs on f0 and f3. The resulting output is then input into a NAND and either a multiplexer in F5M mode or an exclusive OR in F5X mode.

As shown, two of the three inputs into the NAND, XOR, and MUX gates, f0 and f3, are from the LUT. The third input is from the c0 input into PFU. The output of the special function (either XOR or MUX) is f1. Since the XOR and multiplexer share the f1 output, the F5X and F5M modes are mutually exclusive. The output of the NAND is f2.

To use either the F5M or F5X functions, the LUT must be in the F5A/F5B mode. In both the F5X and F5M functions, the outputs of the five-input combinational functions, f0 and f3, are also usable simultaneously with the logic gate outputs.

The output of the multiplexer is:
 $f1 = (HLUTA \times c0) + (HLUTB \times \bar{c0})$

$f1 = (f3 \times c0) + (f0 \times \bar{c0})$

The output of the exclusive OR is:

$f1 = HLUTA \oplus HLUTB \oplus c0$

$f1 = f3 \oplus f0 \oplus c0$

The output of the NAND is:

$f2 = \overline{HLUTA \times HLUTB \times c0}$

$f2 = \overline{f3 \times f0 \times c0}$

Programmable Logic Cells (continued)

2

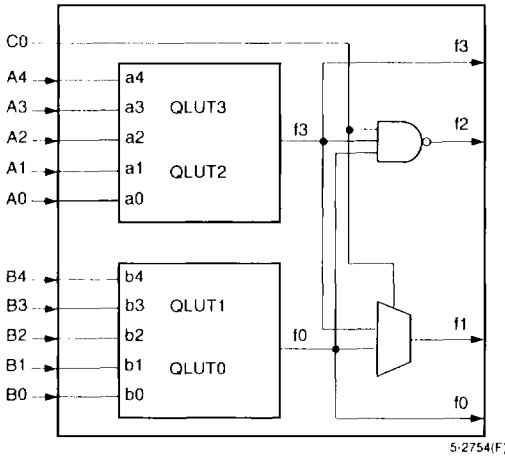

Figure 6. F5M Mode—Multiplexed Function of Two Independent Five-Input Variable Functions

F5M Mode — One Six-Input Variable Function

The LUT can be used to implement any function of six input variables. As shown in Figure 8, five input signals are routed into both the a[4:0] and b[4:0] ports, and the c0 port is used for the sixth input. The output port is f1.

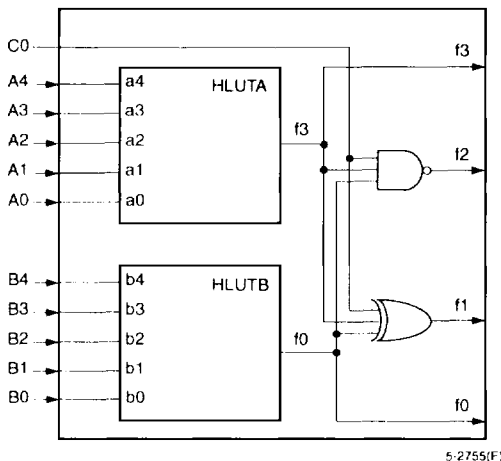

Figure 7. F5X Mode—Exclusive OR Function of Two Independent Five-Input Variable Functions

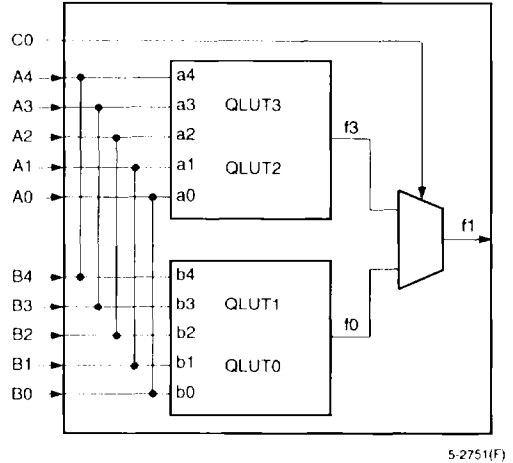

Figure 8. F5M Mode—One Six-Input Variable Function

Ripple Mode

The LUT can do nibble-wide ripple functions with high-speed carry logic. The QLUTs each have a dedicated carry-out net to route the carry to/from the adjacent QLUT. Using the internal carry circuits, fast arithmetic and counter functions can be implemented in one PFU. Similarly, each PFU has carry-in and carry-out ports for fast carry routing between adjacent PFUs.

The ripple mode is generally used in operations on two 4-bit buses. Each QLUT has two operands and a ripple input, and provides a result and ripple (generally carry) output. A single bit is rippled from the previous QLUT and is used as input into the current QLUT. For QLUT0, the ripple input is from the PFU cin port. The cin data can come from either the fast carry routing or the PFU input b4, or it can be tied to logic 1 or logic 0.

The result output and ripple output are calculated by using generate/propagate circuitry. In ripple mode, the two operands are input into a[3:0] and b[3:0]. The four results bits, one per QLUT, are f[3:0] (see Figure 9). The ripple output from QLUT3 can be routed to dedicated carry-out circuitry into any of four adjacent PLCs, or it can be placed on the o4 PFU output, or both. This allows for cascading PLCs in the ripple mode so that nibble-wide ripple functions can be easily expanded to any length. If an up/down counter or adder/subtractor is needed, the control signal is input on a4.

Programmable Logic Cells (continued)

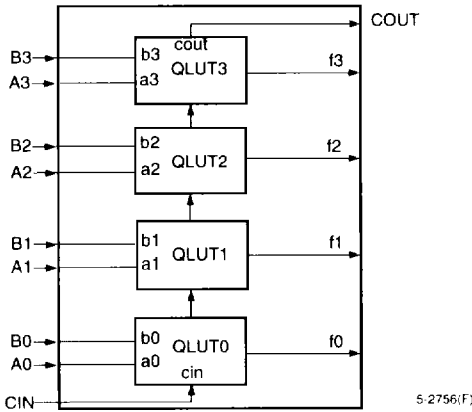

Figure 9. Ripple Mode

Each QLUT generates two separate outputs. One of the two outputs selects whether the carry-in is to be propagated to the carry-out of the current QLUT or if the carry-out needs to be generated. The resulting output is placed on the QLUT output. The result bit is created in one half of the QLUT from a single bit from each input bus along with the ripple input bit. These inputs are also used to create the programmable propagate.

Memory Modes — MA and MB Modes

The LUT in the PFU can be configured as either read/write or read-only memory. A read/write address (a[3:0],b[3:0]), write data (wd[1:0], wd[3:2]), and two write enable (wea, web) ports are used for memory. In memory mode, each HLUT can be used as a 16 x 2 memory. Each HLUT is configured independently, allowing functions such as 16 x 4 memory or a 16 x 2 memory in one HLUT and a logic function of five input variables or less in the other HLUT.

Figure 10 illustrates the use of the LUT for a 16 x 4 memory. When the LUTs are used as memory, there are independent address, input data, and output data buses. If the LUT is used as a 16 x 4 read/write memory, the a[3:0] and b[3:0] ports are address inputs. The a4 and b4 ports are write-enable (we) signals. The wd[3:0] inputs are the data inputs. The f[3:0] data outputs can be routed out on the o[4:0] PFU outputs or to the latch/FFs d[3:0] inputs.

To increase memory address locations (e.g., 32 x 4), two or more PLCs can be used. The address and write data inputs for the two PLCs are tied together (bit by bit) and the data outputs are routed through a 3-statable BIDI and then tied together (bit by bit).

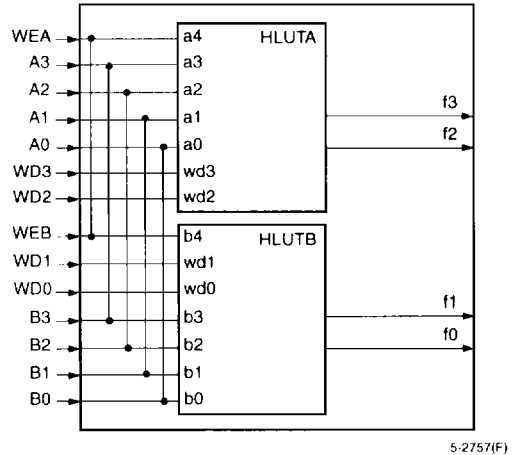

Figure 10. MA/MB Mode—16 x 4 RAM

The write enable and read enable for each PLC is created from an extended address. The read enable is connected to the 3-state enable input to the BIDs for a given PLC and then used to enable the 4 bits of data from a PLC onto the read data bus.

To increase the memory's word size (e.g., 16 x 8), two or more PLCs are used again. The address and write enable of the PLCs are tied together, and the data is different for each PLC. Increasing both the address locations and word size is done by using a combination of these two techniques.

The LUT can be used for both memory and a combinatorial logic function simultaneously. Figure 11 shows the use of a LUT implementing a 16 x 2 RAM (HLUTA) and any function of up to five input variables (HLUTB).

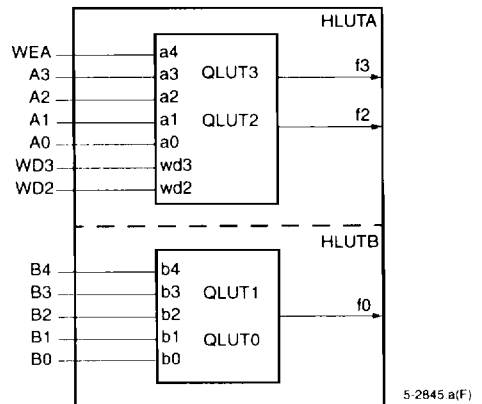

Figure 11. MA/F5 Mode—16 x 2 Memory and One Function of Five Input Variables

Programmable Logic Cells (continued)

Latches/Flip-Flops

The four latches/FFs in the PFU can be used in a variety of configurations. In some cases, the configuration options apply to all four latches/FFs in the PFU. For other options, each latch/FF is independently programmable.

Table 3 summarizes these latch/FF options. The latches/FFs can be configured as either positive or negative level sensitive latches, or positive or negative edge-triggered flip-flops. All latches/FFs in a given PFU share the same clock, and the clock to these latches/FFs can be inverted. The input into each latch/FF is from either the corresponding QLUT output ($f[3:0]$) or the direct data input ($wd[3:0]$). For latches/FFs located in the two outer rings of PLCs, additional inputs are possible. These additional inputs are fast paths from I/O pads located in PICs perpendicular to the PLCs. If the latch/FF is not located in the two outer rings of the PLCs, the latch/FF input can also be tied to logic 0, which is the default. The four latch/FF outputs, $q[3:0]$, can be placed on the five PFU outputs, $o[4:0]$.

Table 3. Configuration RAM Controlled Latch/Flip-Flop Operation

Function	Options
Functionality Common to All Latch/FFs in PFU	
LSR Operation	Asynchronous or Synchronous
Clock Polarity	Noninverted or Inverted
Front-End Select	Direct ($wd[3:0]$) or from LUT ($f[3:0]$)
Functionality Set Individually in Each Latch/FF in PFU	
Latch/FF Mode	Latch or Flip-Flop
Set/Reset Mode	Set or Reset

The four latches/FFs in a PFU share the clock (ck), clock enable (ce), and local set/reset (lsr) inputs. When ce is disabled, each latch/FF retains its previous value when clocked, unless there is an asynchronous set/reset. Both the clock enable and lsr inputs can be inverted to be active-low.

The set/reset operation of the latch/FF is controlled by two parameters: reset mode and set/reset value. When the global ($gsrn$) or local set/reset (lsr) are active, the storage element operates normally as a latch or FF. The reset mode is used to select a synchronous or asynchronous lsr operation. If synchronous, lsr is enabled if clock enable (ce) is active. The clock enable is supported on FFs, not latches. The clock enable function is implemented by using a two-input multiplexer on the FF input, with one input being the

previous state of the FF and the other input being the new data applied to the FF. The select of this two-input multiplexer is clock enable (ce), which selects either the new data or the previous state. When ce is inactive, the FF output does not change when the clock edge arrives.

The global reset ($gsrn$) is only asynchronous, and it sets/resets all latches/FFs in the FPGA based upon the set/reset configuration bit for each latch/FF. The set/reset value determines whether $gsrn$ and lsr are set or reset inputs. The set/reset value is independent for each latch/FF.

If the local set/reset is not needed, the latch/FF can be configured to have a data front-end select. Two data inputs are possible in the front-end select mode, with the lsr signal used to select which data input is used. The data input into each latch/FF is from the output of its associated QLUT $f[3:0]$ or direct from $wd[3:0]$, bypassing the LUT. In the front-end data select mode, both signals are available to the latches/FFs.

For PLCs that are in the two outside rows or columns of the array, the latch/FFs can have two inputs in addition to the f and wd inputs mentioned above. One input is from an I/O pad located at the PIC closest to either the left or right of the given PLC (if the PLC is in the left two columns or right two columns of the array). The other input is from an I/O pad located at the closest PIC either above or below the given PLC (if the PLC is in the top or the bottom two rows). It should be noted that both inputs are available for a 2 x 2 array of PLCs in each corner of the array. For the entire array of PLCs, if either or both of these inputs is unavailable, the latch/FF can be tied to a logic 0 instead.

To speed up the interface between signals external to the FPGA and the latches/FFs, there are direct paths from latch/FF outputs to the I/O pads. This is done for each PLC that is adjacent to a PIC. The latches/FFs can be configured in three modes:

1. Local synchronous set/reset: the input into the PFU's lsr port is used to synchronously set or reset each latch/FF.
2. Local asynchronous set/reset: the input into lsr asynchronously sets or resets each latch/FF.
3. Latch/FF with front-end select: the data select signal (actually lsr) selects the input into the latches/FFs between the LUT output and direct data in.

For all three modes, each latch/FF can be independently programmed as either set or reset. Each latch/FF in the PFU is independently configured to operate as either a latch or flip-flop. Figure 12 provides the logic functionality of the front-end select, global set/reset, and local set/reset operations.

Programmable Logic Cells (continued)

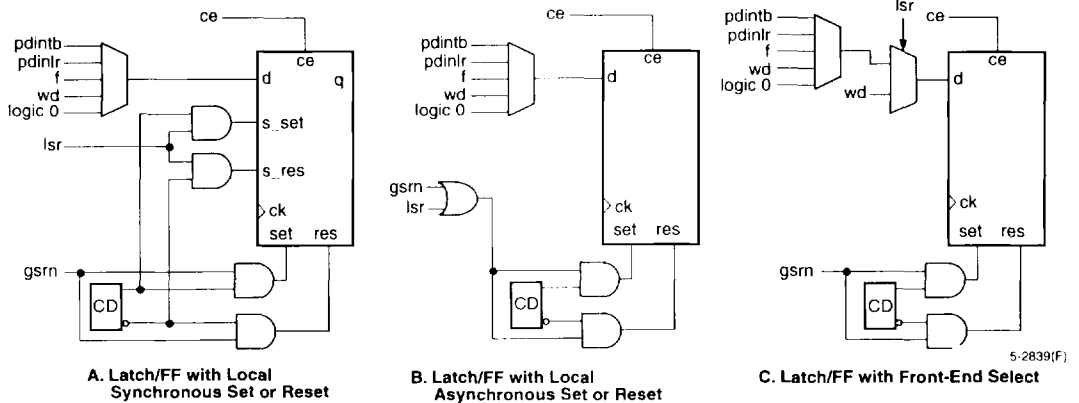

Figure 12. Latch/FF Set/Reset Configurations

PLC Routing Resources

Generally, the ORCA Foundry Development System is used to automatically route interconnections. Interactive routing with the ORCA Foundry design editor (EPIC) is also available for design optimization. To use EPIC for interactive layout, an understanding of the routing resources is needed and is provided in this section.

The routing resources consist of switching circuitry and metal interconnect segments. Generally, the metal lines which carry the signals are designated as routing nodes (R-nodes). The switching circuitry connects the routing nodes, providing one or more of three basic functions: signal switching, amplification, and isolation. A net running from a PFU or PIC output (source) to a PLC or PIC input (destination) consists of one or more R-nodes, connected by switching circuitry designated as configurable interconnect points (CIPs).

The following sections discuss PLC, PIC, and interquad routing resources. This section discusses the PLC switching circuitry, intra-PLC routing, inter-PLC routing, and clock distribution.

Configurable Interconnect Points

The process of connecting R-nodes uses three basic types of switching circuits: two types of configurable interconnect points (CIPs) and bidirectional buffers (BIDs). The basic element in CIPs is one or more pass transistors, each controlled by a configuration RAM bit. The two types of CIPs are the mutually exclusive (or multiplexed) CIP and the independent CIP.

A mutually exclusive set of CIPs contains two or more CIPs, only one of which can be on at a time. An independent CIP has no such restrictions and can be on independent of the state of other CIPs. Figure 13 shows an example of both types of CIPs.

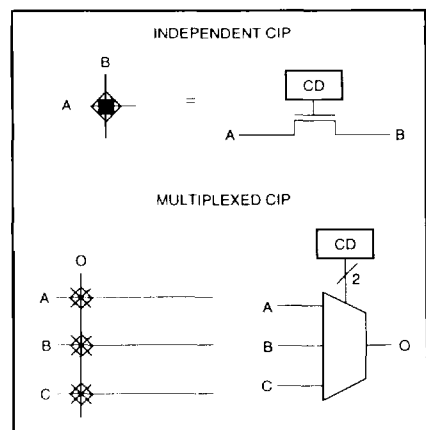

Figure 13. Configurable Interconnect Point

Programmable Logic Cells (continued)

3-Statable Bidirectional Buffers

Bidirectional buffers provide isolation as well as amplification for signals routed a long distance. Bidirectional buffers are also used to drive signals directly onto either vertical or horizontal xL and xH R-nodes (to be described later in the inter-PLC routing section). BIDIs are also used to indirectly route signals through the switching R-nodes. Any number from zero to eight BIDIs can be used in a given PLC.

The BIDIs in a PLC are divided into two nibble-wide sets of four (BIDI and BIDIH). Each of these sets has a separate BIDI controller that can have an application net connected to its TRI input, which is used to 3-state enable the BIDIs. Although only one application net can be connected to both BIDI controllers, the sense of this signal (active-high, active-low, or ignored) can be configured independently. Therefore, one set can be used for driving signals, the other set can be used to create 3-state buses, both sets can be used for 3-state buses, and so forth.

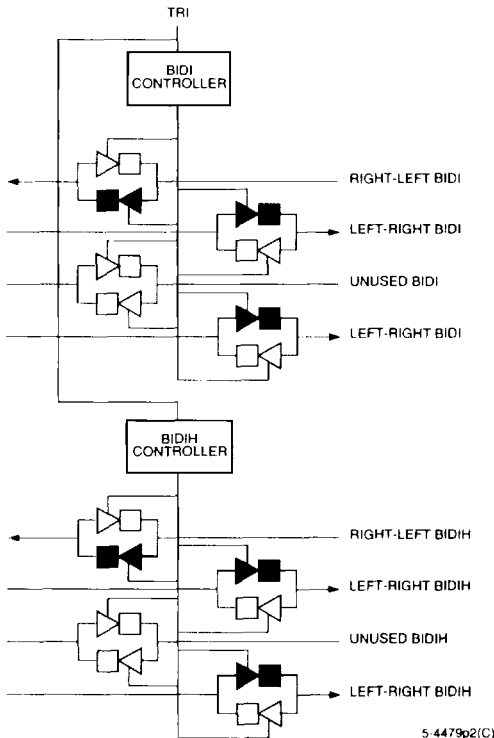

Figure 14. 3-Statable Bidirectional Buffers

Intra-PLC Routing

The function of the intra-PLC routing resources is to connect the PFU's input and output ports to the routing resources used for entry to and exit from the PLC. These are nets for providing PFU feedback, turning corners, or switching from one type of routing resource to another.

PFU Input and Output Ports. There are nineteen input ports to each PFU. The PFU input ports are labelled a[4:0], b[4:0], wd[3:0], c0, ck, lsr, cin, and ce. The six output ports are o[4:0] and cout. These ports correspond to those described in the PFU section.

Switching R-Nodes. There are four sets of switching R-nodes in each PLC, one in each corner. Each set consists of five switching elements, labelled sul[4:0], sur[4:0], sl[4:0], and slr[4:0], for the upper-left, upper-right, lower-left, and lower-right sections of the PFUs, respectively. The switching R-nodes connect to the PFU inputs and outputs as well as the BIDI and BIDIH R-nodes, to be described later. They also connect to both the horizontal and vertical x1 and x4 R-nodes (inter-PLC routing resources, described below) in their specific corner.

One of the four sets of switching R-nodes can be connected to a set of switching R-nodes in each of the four adjacent PLCs or PICs. This allows direct routing of up to five signals without using inter-PLC routing.

BIDI/BIDIH R-Nodes. There are two sets of bidirectional R-nodes in the PLC, each set consisting of four bidirectional buffers. They are designated BIDI and BIDIH and have similar functionality. The BIDI R-nodes are used in conjunction with the xL R-nodes, and the BIDIH R-nodes are used in conjunction with the xH R-nodes. Each side of the four BIDIs in the PLC is connected to a BIDI R-node on the left (BL[3:0]) and on the right (BR[3:0]). These R-nodes can be connected to the xL R-nodes through CIPs, with BL[3:0] connected to the vertical xL R-nodes and BR[3:0] connected to the horizontal xL R-nodes. Both BL[3:0] and BR[3:0] have CIPs which connect to the switching R-nodes.

Similarly, each side of the four BIDIHs is connected to a BIDIH R-node: BLH[3:0] on the left and BRH[3:0] on the right. These R-nodes can also be connected to the xH R-nodes through CIPs, with BLH[3:0] connected to the vertical xH R-nodes and BRH[3:0] connected to the horizontal xH R-nodes. Both BLH[3:0] and BRH[3:0] have CIPs which connect to the switching R-nodes.

CIPs are also provided to connect the BIDIH and BIDI R-nodes together on each side of the BIDIs. For example, BLH3 can connect to BL3, while BRH3 can connect to BR3.

2

Programmable Logic Cells (continued)

Inter-PLC Routing Resources

The inter-PLC routing is used to route signals between PLCs. The R-nodes occur in groups of four, and differ in the numbers of PLCs spanned. The x1 R-nodes span one PLC, the x4 R-nodes span four PLCs, the xH R-nodes span one-half the width (height) of the PLC array, and the xL R-nodes span the width (height) of the PLC array. All types of R-nodes run in both horizontal and vertical directions. Table 4 shows the groups of inter-PLC R-nodes in each PLC. In the table, there are two rows/columns each for x1 and x4 lines. In the design editor, the horizontal x1 and x4 R-nodes are located above and below the PFU. Similarly, the vertical segments are located on each side. The xL and xH R-nodes only run below and to the left of the PFU. The indexes specify individual R-nodes within a group. For example, the vx4[2] R-node runs vertically to the left of the PFU, spans four PLCs, and is the third line in the 4-bit wide bus.

Table 4. Inter-PLC Routing Resources

Horizontal R-Nodes	Vertical R-Nodes	Distance Spanned
hx1[3:0]	vx1[3:0]	One PLC
hx1[7:4]	vx1[7:4]	One PLC
hx4[3:0]	vx4[3:0]	Four PLCs
hx4[7:4]	vx4[7:4]	Four PLCs
hxL[3:0]	vxL[3:0]	PLC Array
hxH[3:0]	vxH[3:0]	1/2 PLC Array
ckl, ckr	ckt, ckb	PLC Array

Figure 15 shows the inter-PLC routing within one PLC. Figure 16 provides a global view of inter-PLC routing resources across multiple PLCs.

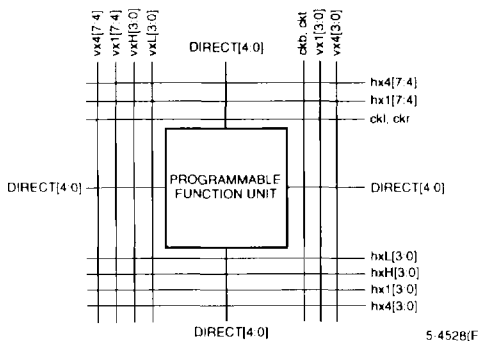

Figure 15. Single PLC View of Inter-PLC R-Nodes

x1 R-Nodes. There are a total of 16 x1 R-nodes per PLC: eight vertical and eight horizontal. Each of these is subdivided into nibble-wide buses: hx1[3:0], hx1[7:4], vx1[3:0], and vx1[7:4]. An x1 line is one PLC long. If a net is longer than one PLC, an x1 R-node can be lengthened to n times its length by turning on n - 1 CIPs. A signal is routed onto an x1 R-node via the switching R-nodes.

x4 R-Nodes. There are four sets of four x4 R-nodes, for a total of 16 x4 R-nodes per PLC. They are hx4[3:0], hx4[7:4], vx4[3:0], and vx4[7:4]. Each set of x4 R-nodes is twisted each time it passes through a PLC, and one of the four is broken with a CIP. This allows a signal to be routed for a length of four cells in any direction on a single line without additional CIPs. The x4 R-nodes can be used to route any nets that require minimum delay. A longer net is routed by connecting two x4 R-nodes together by a CIP. The x4 R-nodes are accessed via the switching R-nodes.

xL R-Nodes. The long xL R-nodes run vertically and horizontally the height and width of the array, respectively. There are a total of eight xL R-nodes per PLC: four horizontal (hxL[3:0]) and four vertical (vxL[3:0]). Each PLC column has four xL lines, and each PLC row has four xL R-nodes. Each of the xL R-nodes connects to the two PICs at either end. The ATT2C12, which consists of a 18 x 18 array of PLCs, contains 72 vxL and 72 hxL R-nodes. They are intended primarily for global signals which must travel long distances and require minimum delay and/or skew, such as clocks.

There are three methods for routing signals onto the xL R-nodes. In each PLC, there are two long line drivers: one for a horizontal xL R-node, and one for a vertical xL R-node. Using the long line drivers produces the least delay. The xL R-nodes can also be driven directly by PFU outputs using the BIDI R-nodes. In the third method, the xL R-nodes are accessed by the bidirectional buffers, again using the BIDI R-nodes.

Programmable Logic Cells (continued)

xH R-nodes. Four by half (xH) R-nodes run horizontally and four xH R-nodes run vertically in each row and column in the array. These R-nodes travel a distance of one-half the PLC array before being broken in the middle of the array, where they connect to the interquad block (discussed later). They also connect at the periphery of the FPGA to the PICs, like the xL R-nodes. The xH R-nodes do not twist like xL R-nodes, allowing nibble-wide buses to be routed easily.

Two of the three methods of routing signals onto the xL R-nodes can also be used for the xH R-nodes. A special xH line driver is not supplied for the xH R-nodes.

Clock R-Nodes. For a very fast and low-skew clock (or other global signal tree), clock R-nodes run the entire height and width of the PLC array. There are two horizontal clock R-nodes per PLC row (CKL, CKR) and two vertical clock R-nodes per PLC column (CKT, CKB). The source for these clock R-nodes can be any of the four I/O buffers in the PIC. The horizontal clock R-nodes in a row (CKL and CKR) are driven by the left and right PICs, respectively. The vertical clock R-nodes in a column (CKT, CKB) are driven by the top and bottom PICs, respectively.

The clock R-nodes are designed to be a clock spine. In each PLC, there is a fast connection available from the clock R-node to the long-line driver (described earlier). With this connection, one of the clock R-nodes in each PLC can be used to drive one of the four xL R-nodes perpendicular to it, which, in turn, creates a clock tree. This feature is discussed in detail in the clock distribution section.

Minimizing Routing Delay

The CIP is an active element used to connect two R-nodes. As an active element, it adds significantly to the resistance and capacitance of a net, thus increasing the net's delay. The advantage of the x1 R-node over a x4 R-node is routing flexibility. A net from PLC db to PLC cb is easily routed by using x1 R-nodes. As more CIPs are added to a net, the delay increases. To increase speed, routes that are greater than two PLCs away are routed on the x4 R-nodes because a CIP is located only in every fourth PLC. A net which spans eight PLCs requires seven x1 R-nodes and six CIPs. Using x4 R-nodes, the same net uses two R-nodes and one CIP.

All routing resources in the PLC can carry 4-bit buses. In order for data to be used at a destination PLC that is in data path mode, the data must arrive unscrambled. For example, in data path operation, the least significant bit 0 must arrive at either a[0] or b[0]. If the bus is to be routed by using either x4 or xL R-nodes (both of which twist as they propagate), the bus must be placed on the appropriate lines at the source PLC so that the data arrives at the destination unscrambled. The switching R-nodes provide the most efficient means of connecting adjacent PLCs. Signals routed with these R-nodes have minimum propagation delay.

Programmable Logic Cells (continued)

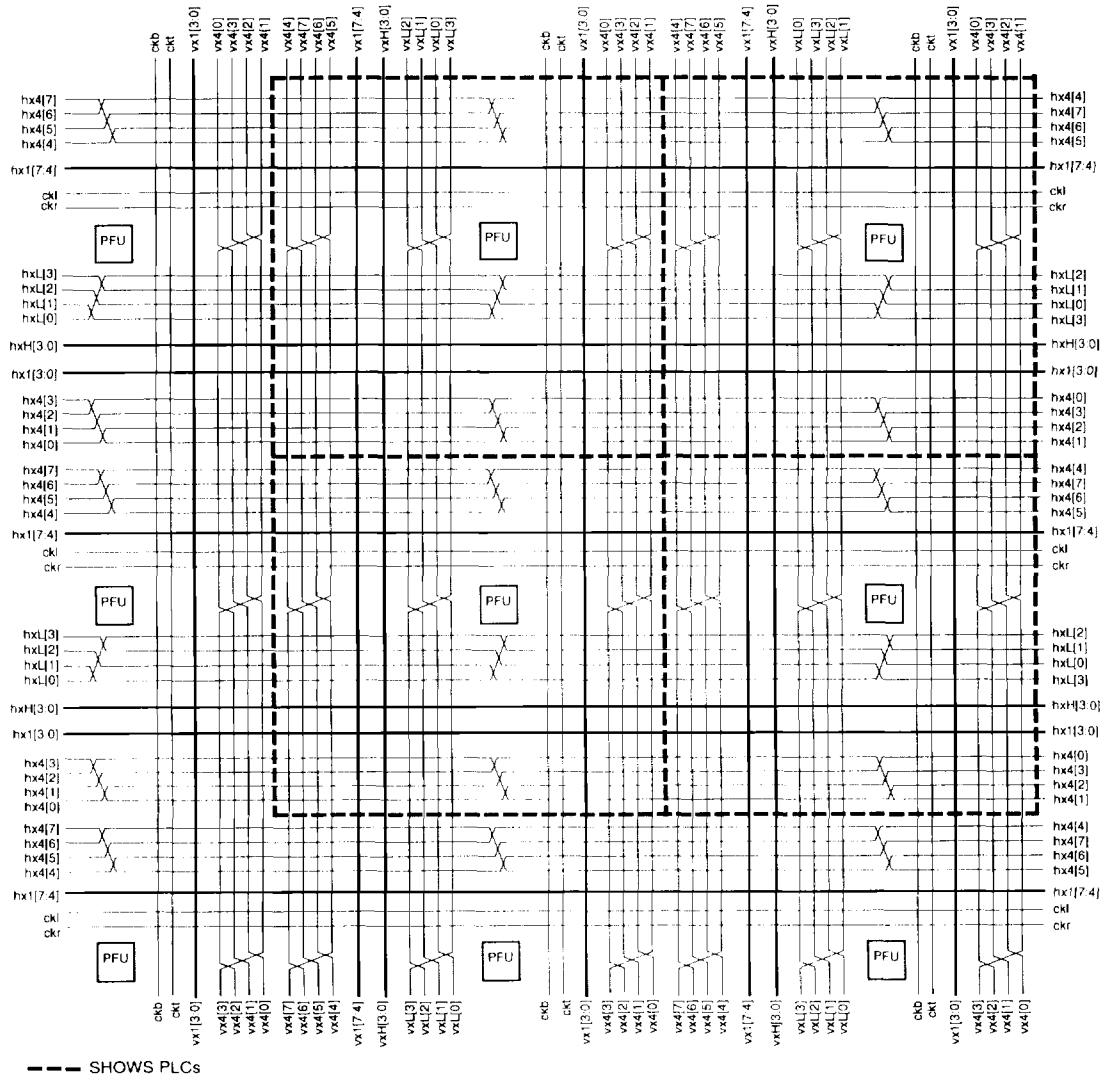

5.2841(C)2C

Figure 16. Multiple PLC View of Inter-PLC Routing

Programmable Logic Cells (continued)

PLC Architectural Description

Figure 17 is an architectural drawing of the PLC which reflects the PFU, the R-nodes, and the CIPs. A discussion of each of the letters in the drawing follows.

A. These are switching R-nodes which give the router flexibility. In general switching theory, the more levels of indirection there are in the routing, the more routable the network is. The switching R-nodes can also connect to adjacent PLCs.

The switching R-nodes provide direct connections to PLCs directly to the top, bottom, left, and right, without using other routing resources. The ability to disable this connection between PLCs is provided so that each side of these connections can be used exclusively as switching R-nodes in their respective PLC.

B. These CIPs connect the x1 routing. These are located in the middle of the PLC to allow the block to connect to either the left end of the horizontal x1 R-node from the right or the right end of the horizontal x1 R-node from the left, or both. By symmetry, the same principle is used in the vertical direction. The x1 lines are not twisted, making them suitable for data paths.

C. This set of CIPs is used to connect the x1 and x4 nets to the switching R-nodes or to other x1 and x4 nets. The CIPs on the major diagonal allow data to be transmitted from x1 nets to the switching R-nodes without being scrambled. The CIPs on the major diagonal also allow unscrambled data to be passed between the x1 and x4 nets.

In addition to the major diagonal CIPs for the x1 lines, other CIPs provide an alternative entry path into the PLC in case the first one is already used. The other CIPs are arrayed in two patterns, as shown. Both of these patterns start with the main diagonal, but the extra CIPs are arrayed on either a parallel diagonal shifted by one or shifted by two (modulo the size of the vertical bus (5)). This allows any four application nets incident to the PLC corner to be transferred to the five switching R-nodes in that corner. Many patterns of five nets can also be transferred.

D. The x4 R-nodes are twisted at each PLC. One of the four x4 lines is broken with a CIP, which allows a signal to be routed a distance of four PLCs in any direction on a single R-node without an intermediate CIP. The x4 R-nodes are less populated with CIPs than the x1 lines to increase their speed. A CIP can be enabled to extend an x4 R-node four more PLCs, and so on.

For example, if an application signal is routed onto hx4[4] in a PLC, it appears on hx4[5] in the PLC to the right. This signal step-up continues until it reaches hx4[7], two PLCs later. At this point, the user can break the connection or continue the signal for another four PLCs.

E. These symbols are bidirectional buffers (BIDIs). There are four BIDIs per PLC, and they provide signal amplification as needed to decrease signal delay. The BIDIs are also used to transmit signals on xL lines.

F. These are the BIDI and BIDIH controllers. The 3-state control signal can be disabled. They can be configured as active-high or active-low independently of each other.

G. This set of CIPs allows a BIDI to get or put a signal from one set of switching R-nodes on each side. The BIDIs can be accessed by the switching R-nodes. These CIPs allow a nibble of data to be routed through the BIDIs and continue to a subsequent block. They also provide an alternative routing resource to improve routability.

H. These CIPs are used to take data from/to the BIDIs to/from the xL R-nodes. These CIPs have been optimized to allow the BIDI buffers to drive the large load usually seen when using xL R-nodes.

I. Each latch/FF can accept data: from a LUT output; from a direct data input signal from general routing; or, as in the case of PLCs located in the two rows (columns) adjacent to PICs, directly from the pad. In addition, the LUT outputs can bypass the latches/FFs completely and output data on the general routing resources. The four inputs shown are used as the direct input to the latches/FFs from general routing resources. If the LUT is in memory mode, the four inputs wd[3:0] are the data input to the memory.

Programmable Logic Cells (continued)

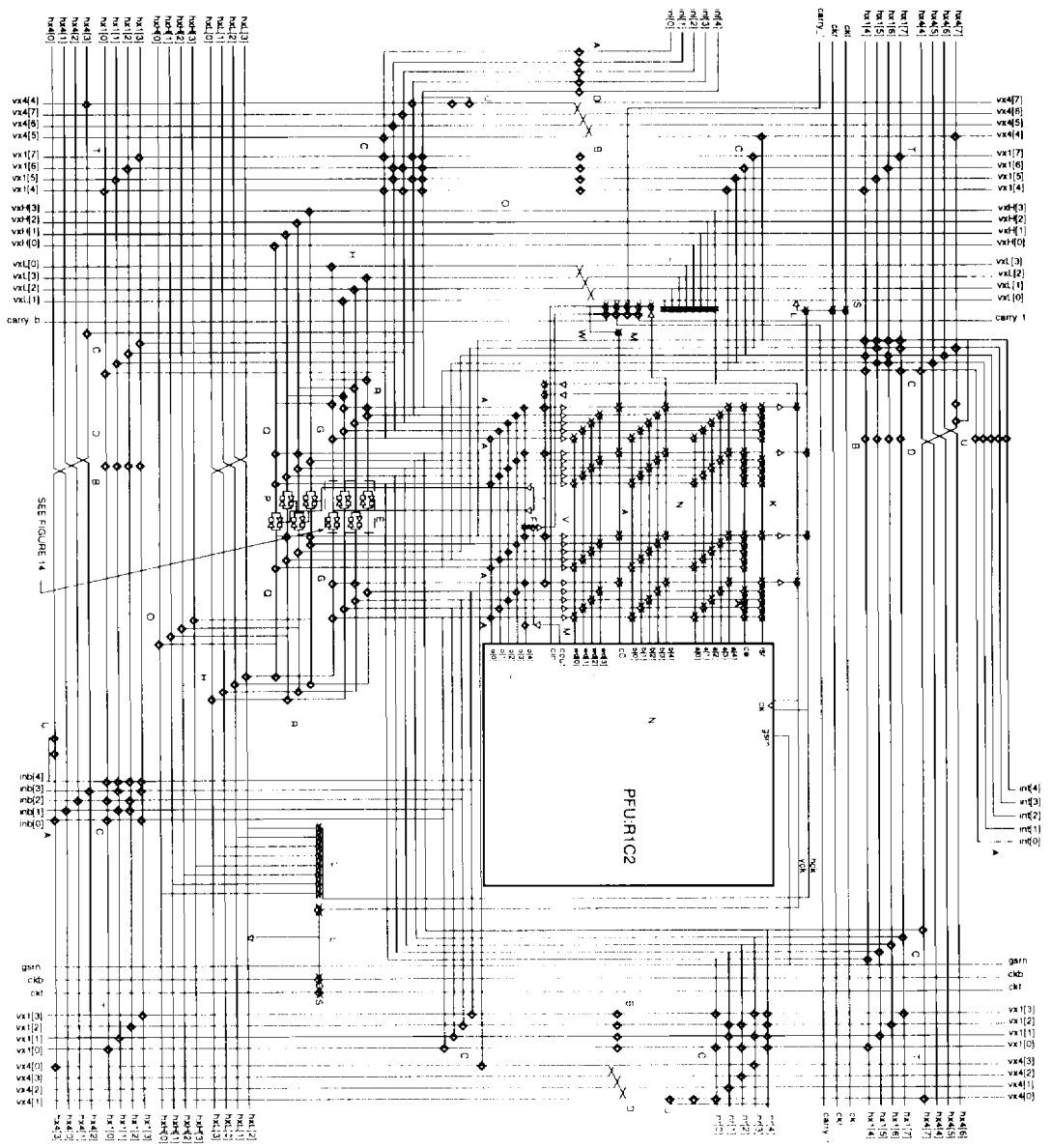

5-4479(C)

Figure 17. PLC Architecture

Programmable Logic Cells (continued)

J. Any five of the eight output signals can be routed out of the PLC. The eight signals are the four LUT outputs (f0, f1, f2, and f3) and the four latch/FF outputs (q0, q1, q2, and q3). This allows the user to access all four latch/FF outputs, read the present state and next state of a latch/FF, build a 4-bit shift register, etc. Each of the outputs can drive any number of the five PFU outputs. The speed of a signal can be increased by dividing its load among multiple PFU output drivers.

K. These lines deliver the auxiliary signals clock enable and set/reset to the latches/FFs. All four of the latches/FFs share these signals.

L. This is the clock input to the latches/FFs. Any of the horizontal and vertical xH or xL lines can drive the clock of the PLC latches/FFs. Long line drivers are provided so that a PLC can drive one xL R-node in the horizontal direction and one xL R-node in the vertical direction. The xL lines in each direction exhibit the same properties as x4 lines, except there are no CIPs. The clock R-nodes (ckl, ckr, ckt, and ckb) and multiplexers/drivers are used to connect to the xL R-nodes for low-skew, low-delay global signals.

The long lines run the length or width of the PLC array. They rotate to allow four PLCs in one row or column to generate four independent global signals. These lines do not have to be used for clock routing. Any highly used application net can use this resource, especially one requiring low skew.

M. These R-nodes are used to route the fast carry signal to/from the neighboring four PLCs. The carry-out (cout) of the PFU can also be routed out of the PFU onto the fifth output (o4). The carry-in (cin) signal can also be supplied by the b4 input to the PFU.

N. These are the 11 logic inputs to the LUT. The a[4:0] inputs are provided into HLUTA, and the b[4:0] inputs are provided into HLUTB. The c0 input bypasses the main LUT and is used in the pfumux, pfuxor, and pfunand functions (F5M, F5X modes). Since this input bypasses the LUT, it can be used as a fast path around the LUT, allowing the implementation of fast, wide combinatorial functions. The c0 input can be disabled or inverted.

O. The xH R-nodes run one-half the length (width) of the array before being broken by a CIP.

P. The BIDIHs are used to access the xH R-nodes.

Q. The BIDIH R-nodes are used to connect the BIDIHs to the xsw R-nodes, the xH R-nodes, or the BIDI R-nodes.

R. These CIPs connect the BIDI R-nodes and the BIDIH R-nodes.

S. These are clock R-nodes (ckt, ckb, ckl, and ckr) with the multiplexers and drivers to connect to the xL R-nodes.

T. These CIPs connect x1 R-nodes which cross in each corner to allow turns on the x1 R-nodes without using the xsw R-nodes.

U. These CIPs connect x4 R-nodes and xsw R-nodes, allowing nets that run a distance that is not divisible by four to be routed more efficiently.

V. This routing structure allows any PFU output, including LUT and latch/FF outputs, to be placed on o4 and be routed onto the fast carry routing.

W. This routing structure allows the fast carry routing to be routed onto the c0 PFU input.

Programmable Input/Output Cells

The programmable input/output cells (PICs) are located along the perimeter of the device. Each PIC interfaces to four bond pads and contains the necessary routing resources to provide an interface between I/O pads and the PLCs. Each PIC is composed of input buffers, output buffers, and routing resources as described below. Table 5 provides an overview of the programmable functions in an I/O cell. Figure 18 is a simplified diagram of the functionality of the ORCA series I/O cells.

Table 5. Input/Output Cell Options

Input	Option
Input Levels	TTL/CMOS
Input Speed	Fast/Delayed
Float Value	Pull-up/Pull-down/None
Direct-in to FF	Fast/Delayed
Output	Option
Output Drive	12 mA/6 mA or 6 mA/3 mA
Output Speed	Fast/Slewlim/Sinklim
Output Source	FF Direct-out/General Routing
Output Sense	Active-high/-low
3-State Sense	Active-high/-low (3-state)

Inputs

Each I/O can be configured to be either an input, an output, or bidirectional I/O. Inputs can be configured as either TTL or CMOS compatible. To allow zero hold time on PLC latches/FFs, the input signal can be delayed. Pull-up or pull-down resistors are available on inputs to minimize power consumption.

A fast path from the input buffer to the clock R-nodes is also provided. Any one of the four I/O pads on any PIC can be used to drive the clock R-node generated in that PIC.

To reduce the time required to input a signal into the FPGA, a dedicated path (pdin) from the I/O pads to the PFU flip-flops is provided. Like general input signals, this signal can be configured as normal or delayed. The delayed direct input can be selected independently from the delayed general input. If the fast clock routing is selected from a given I/O pad, then the direct input signal is automatically delayed, decreasing the delay of the fast clock.

Inputs should have transition times of less than 500 ns and should not be left floating. If an input can float, a pull-up or pull-down should be enabled. Floating inputs increase power consumption, produce oscillations, and increase system noise. The inputs have a typical hysteresis of approximately 280 mV to reduce sensitivity to input noise. The PIC contains input circuitry which provides protection against latch-up and electrostatic discharge.

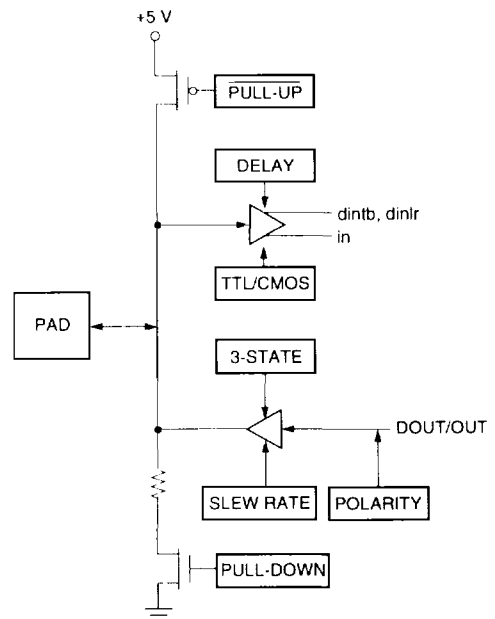

Figure 18. Simplified Diagram of Programmable I/O Cell

Programmable Input/Output Cells

(continued)

Outputs

The PIC's output drivers have programmable drive capability and slew rates. Three propagation delays (fast, slewlum, sinklum) are available on output drivers. The sinklum mode has the longest propagation delay and is used to minimize system noise and minimize power consumption. The fast and slewlum modes allow critical timing to be met.

The drive current is 12 mA sink/6 mA source for the slewlum and fast output speed selections and 6 mA sink/3 mA source for the sinklum output. Two adjacent outputs can be interconnected to increase the output sink current to 24 mA.

All outputs that are not speed critical should be configured as sinklum to minimize power and noise. The number of outputs that switch simultaneously in the same direction should be limited to minimize ground bounce. To minimize ground bounce problems, locate heavily loaded output buffers near the ground pads. Ground bounce is generally a function of the driving circuits, traces on the PCB, and loads and is best determined with a circuit simulation.

Outputs can be inverted, and 3-state control signals can be active-high or active-low. An open-drain output may be obtained by using the same signal for driving the output and 3-state signal nets so that the buffer output is enabled only by a low. At powerup, the output drivers are in slewlum mode, and the input buffers are configured as TTL-level compatible with a pull-up. If an output is not to be driven in the selected configuration mode, it is 3-stated.

Global 3-State Functionality

To increase the testability of the ORCA Series FPGAs, the global 3-state function (*ts_all*) disables the device. The *ts_all* signal is driven from either an external pin or an internal signal. Before and during configuration, the *ts_all* signal is driven by the input pad *RD_CFGN*. After configuration, the *ts_all* signal can be disabled, driven from the *RD_CFGN* input pad, or driven by a general routing signal in the upper-right corner. Before configuration, *ts_all* is active-low; after configuration, the sense of *ts_all* can be inverted. The following occur when *ts_all* is activated:

1. All of the user I/O output buffers are 3-stated, the user I/O input buffers are pulled up (with the pull-down disabled), and the input buffers are configured with TTL input thresholds.
2. The *TDO/RD_DATA* output buffer is 3-stated.
3. The *RD_CFGN*, *RESET*, and *PRGM* input buffers remain active with a pull-up.
4. The *DONE* output buffer is 3-stated and the input buffer is pulled-up.

PIC Routing Resources

The PIC routing is designed to route 4-bit wide buses efficiently. For example, any four consecutive I/O pads can have both their input and output signals routed into one PLC. Using only PIC routing, either the input or output data can be routed to/from a single PLC from/to any eight pads in a row.

The connections between PLCs and the I/O pad are provided by two basic types of routing resources. These are routing resources internal to the PIC and routing resources used for PIC-PLC connection. Figure 19 and Figure 20 show a high-level and detailed view of these routing resources.

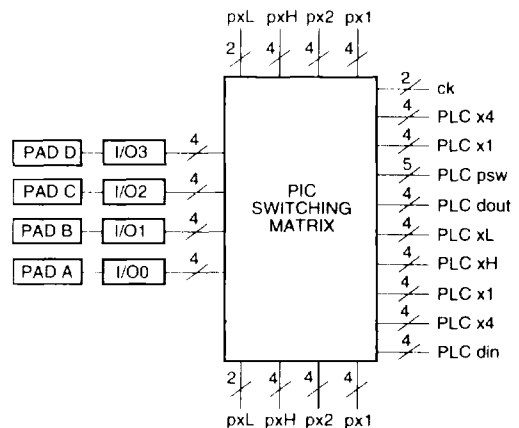

5-4504(C)2C

Figure 19. Simplified PIC Routing Diagram

Programmable Input/Output Cells

(continued)

The PIC's name is represented by a two-letter designation to indicate on which side of the device it is located followed by a number to indicate in which row or column it is located. The first letter, P, designates that the cell is a PIC and not a PLC. The second letter indicates the side of the array where the PIC is located. The four sides are left (L), right (R), top (T), and bottom (B). The individual I/O pad is indicated by a single letter (either A, B, C, or D) placed at the end of the PIC name. As an example, PL10A indicates a pad located on the left side of the array in the tenth row.

Each PIC has four pads and each pad can be configured as an input, an output (3-statable), a direct output, or a bidirectional I/O. When the pads are used as inputs, the external signals are provided to the internal circuitry at in[3:0]. When the pads are used to provide direct inputs to the latches/FFs, they are connected through din[3:0]. When the pads are used as outputs, the internal signals connect to the pads through out[3:0]. When the pads are used as direct outputs, the output from the latches/flip-flops in the PLCs to the PIC is designated dout[3:0]. When the outputs are 3-statable, the 3-state enable signals are ts[3:0].

Routing Resources Internal to the PIC

For inter-PIC routing, the PIC contains fourteen R-nodes used to route signals around the perimeter of the FPGA. Figure 19 shows these lines running vertically for a PIC located on the left side. Figure 20 shows the R-nodes running horizontally for a PIC located at the top of the FPGA.

pxL R-Nodes. Each PIC has two pxL R-nodes, labelled pxL[1:0]. Like the xL R-nodes of the PLC, the pxL R-nodes span the entire edge of the FPGA.

pxH R-Nodes. Each PIC has four pxH R-nodes, labelled pxH[3:0]. Like the xH R-nodes of the PLC, the pxH R-nodes span 1/2 the edge of the FPGA.

px2 R-Nodes. There are four px2 R-nodes in each PIC, labelled px2[3:0]. The px2 R-nodes pass through two adjacent PICs before being broken. These are used to route nets around the perimeter a distance of two or more PICs.

px1 R-Nodes. Each PIC has four px1 R-nodes, labelled px1[3:0]. The px1 R-nodes are one PIC long and are extended to adjacent PICs by enabling CIPs.

Programmable Input/Output Cells

(continued)

PIC Architectural Description

The PIC architecture given in Figure 20 is described using the following letter references. The figure depicts a PIC at the top of the array, so inter-PIC routing is horizontal and the indirect PIC-PLC routing is horizontal to vertical. In some cases, letters are provided in more than one location to indicate the path of an R-node.

- 2**
- A.** As in the PLCs, the PIC contains a set of R-nodes which run the length (width) of the array. The pxL R-nodes connect in the corners of the array to other pxL R-nodes. The pxL R-nodes also connect to the PIC BIDI, PIC BIDIH, and LLDRV R-nodes. As in the PLC xL R-nodes, the pxH R-nodes twist as they propagate through the PICs.
 - B.** As in the PLCs, the PIC contains a set of R-nodes which run one-half the length (width) of the array. The pxH R-nodes connect in the corners and in the middle of the array perimeter to other pxH R-nodes. The pxH R-nodes also connect to the PIC BIDI, PIC BIDIH, and LLDRV R-nodes. As in the PLC xH R-nodes, the pxH R-nodes do not twist as they propagate through the PICs.
 - C.** The px2[3:0] R-nodes span a length of two PICs before intersecting with a CIP. The CIP allows the length of a path using px2 R-nodes to be extended two PICs.
 - D.** The px1[3:0] R-nodes span a single PIC before intersecting with a CIP. The CIP allows the length of a path using px1 R-nodes to be extended by one PIC.
 - E.** These are four dedicated direct output R-nodes connected to the output buffers. The dout[3:0] signals go directly from a PLC latch/FF to an output buffer, minimizing the latch/FF to pad propagation delay.
 - F.** This is a direct path from the input pad to the PLC latch/flip-flops in the two rows (columns) adjacent to PICs. This input allows a reduced setup time. Direct inputs from the top and bottom PIC rows are pdintb[3:0]. Direct inputs from the left and right PIC columns are pdinlr[3:0].
 - G.** The out[3:0], ts[3:0], and in[3:0] signals for each I/O pad can be routed directly to the adjacent PLC's switching R-nodes.
 - H.** The four TRIDI buffers allow connections from the pads to the PLC xL R-nodes. The TRIDIs also allow connections between the PLC xL R-nodes and the pBIDI R-nodes, which are described in **J** below.
 - I.** The four TRIDIH buffers allow connections from the pads to the PLC xH R-nodes. The TRIDIHs also allow connections between the PLC xH R-nodes and the pBIDIH R-nodes, which are described in **K** below.
 - J.** The pBIDI R-nodes (bidi[3:0]) connect the pxL R-nodes, pxH R-nodes, and the px1 R-nodes. These are bidirectional in that the path can be from the pxL, pxH, or px1 R-nodes to the xL R-nodes, or from the xL R-nodes to the pxL, pxH, or px1 R-nodes.
 - K.** The pBIDIH R-nodes (bidih[3:0]) connect the pxL R-nodes, pxH R-nodes, and the px1 R-nodes. These are bidirectional in that the path can be from the pxL, pxH, or px1 R-nodes to the xH R-nodes, or from the xH R-nodes to the pxL, pxH, or px1 R-nodes.
 - L.** The llin[3:0] R-nodes provide a fast connection from the I/O pads to the xL and xH R-nodes.
 - M.** This set of CIPs allows the eight x1 R-nodes (four on each side) of the PLC perpendicular to the PIC to be connected to either the px1 or px2 R-nodes in the PIC.
 - N.** This set of CIPs allows the eight x4 R-nodes (four on each side) of the PLC perpendicular to the PIC to be connected to the px1 R-nodes. This allows fast access to/from the I/O pads from/to the PLCs.
 - O.** All four of the PLC x4 R-nodes in a group connect to all four of the PLC x4 R-nodes in the adjacent PLC through a CIP. (This differs from the Lucent ORCA 1C Series in which two of the x4 R-nodes in adjacent PLCs are directly connected without any CIPs.)
 - P.** The long line driver (LLDRV) R-node can be driven by the xsw4 switching R-node of the adjacent PLC. To provide connectivity to the pads, the LLDRV R-node can also connect to any of the four pxH or to one of the pxL R-nodes. The 3-state enable (ts[i]) for all four I/O pads can be driven by xsw4, pxH, or pxL R-nodes.
 - Q.** For fast clock routing, one of the four I/O pads in each PIC can be selected to be driven onto a dedicated clock R-node. The clock R-node spans the length (width) of the PLC array. This dedicated clock R-node is typically used as a clock spine. In the PLCs, the spine is connected to an xL R-node to provide a clock branch in the perpendicular direction. Since there is another clock R-node in the PIC on the opposite side of the array, only one of the I/O pads in a given row (column) can be used to generate a global signal in this manner, if all PLCs are driven by the signal.

Programmable Input/Output Cells (continued)

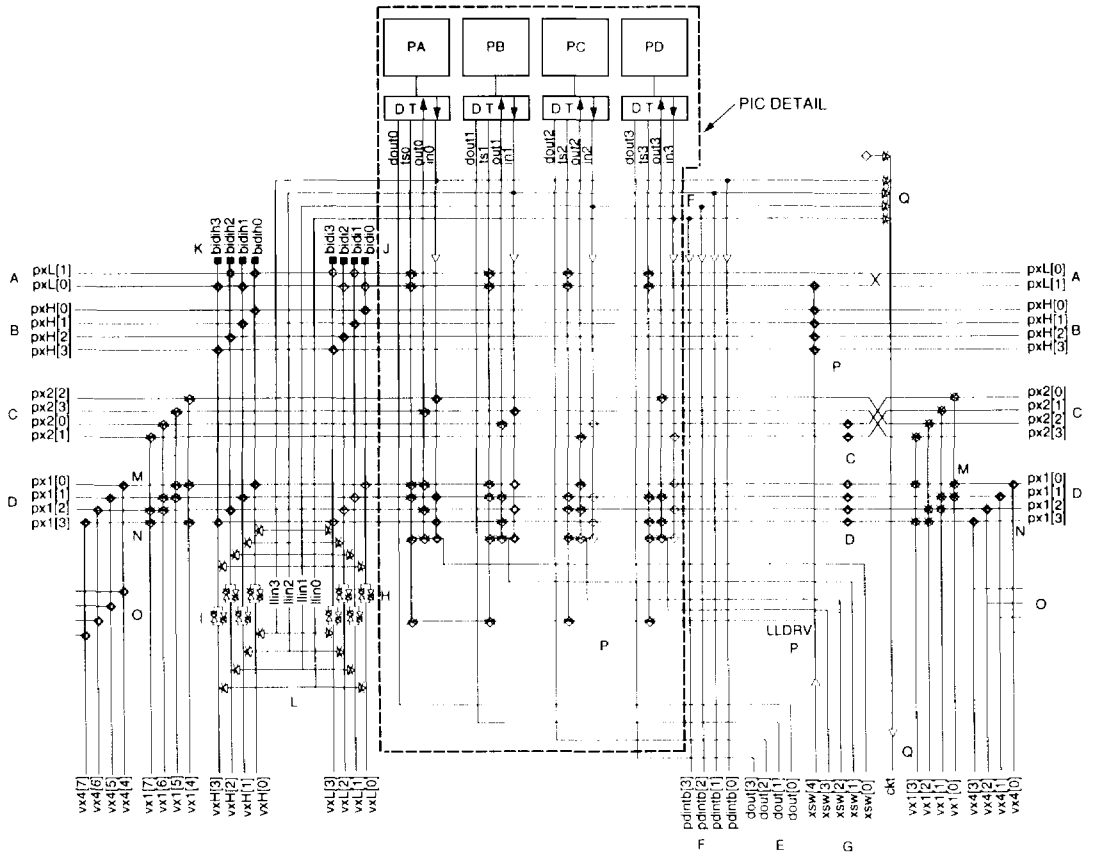

5-2843(C)2C

Figure 20. PIC Architecture

Programmable Input/Output Cells

(continued)

2

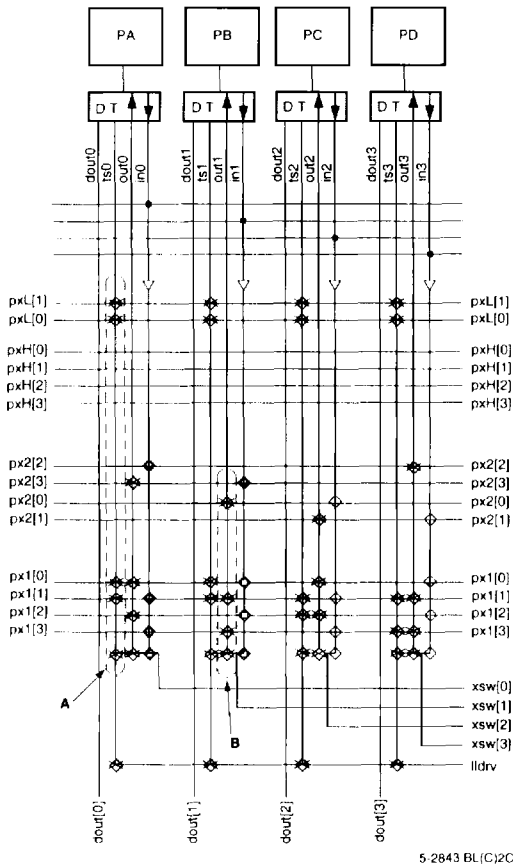

Figure 21. PIC Detail

PLC-PIC Routing Resources

There is no direct connection between the inter-PIC R-nodes and the PLC R-nodes. All connections to/from the PLC must be done through the connecting R-nodes which are perpendicular to the R-nodes in the PIC. The use of perpendicular and parallel R-nodes will be clearer if the PLC and PIC architectures (Figure 17 and Figure 20) are placed side by side. Twenty-nine R-nodes in the PLC can be connected to the fifteen R-nodes in the PIC.

Multiple connections between the PIC px1 R-nodes and the PLC x1 R-nodes are available. These allow buses placed in any arbitrary order on the I/O pads to be unscrambled when placed on the PLC x1 R-nodes. Connections are also available between the PIC px2 R-nodes and the PLC x1 R-nodes.

There are eight tridirectional (four TRIDI/four TRIDIH) buffers in each PIC; they can do the following:

- Drive a signal from an I/O pad onto one of the adjacent PLC's xL or xH R-nodes
- Drive a signal from an I/O pad onto one of the two pxL or four pxH R-nodes in the PIC
- Drive a signal from the PLC xL or xH R-nodes onto one of the two pxL or four pxH R-nodes in the PIC
- Drive a signal from the PIC pxL or pxH R-nodes onto one of the PLC xL or xH R-nodes

Figure 21 shows paths to and from pads and the use of MUX CIPs to connect R-nodes. Detail A shows six MUX CIPs for the pad P0 used to construct the net for the 3-state signal. In the MUX CIP, one of six R-nodes is connected to an R-node to form the net. In this case, the ts0 signal can be driven by either of the two pxLs, px1[0], px1[1], xsw[0], or the lldrv R-nodes. Detail B shows the four MUX CIPs used to drive the P1 output. The source R-node for out1 is either xsw[1], px1[1], px1[3], or px2[2].

Interquad Routing

In the ORCA 2C Series devices, the PLC array is split into four equal quadrants. In between these quadrants, routing has been added to route signals between the quadrants, especially to the quadrant in the opposite corner. The two types of interquad blocks, vertical and horizontal, are pitch matched to PICs. Vertical interquad blocks (vIQ) run between quadrants on the left and right, while horizontal interquad blocks (hIQ) run

between top and bottom quadrants. Since hIQ and vIQ blocks have the same logic, only the hIQ block is described below.

The interquad routing connects xL and xH R-nodes. It does not affect local routing (xsw, x1, x4, fast carry), so local routing is the same, whether PLC-PLC connections cross quadrants or not. There are no connections to the local R-nodes in the interquad blocks. Figure 22 presents a (not to scale) view of interquad routing.

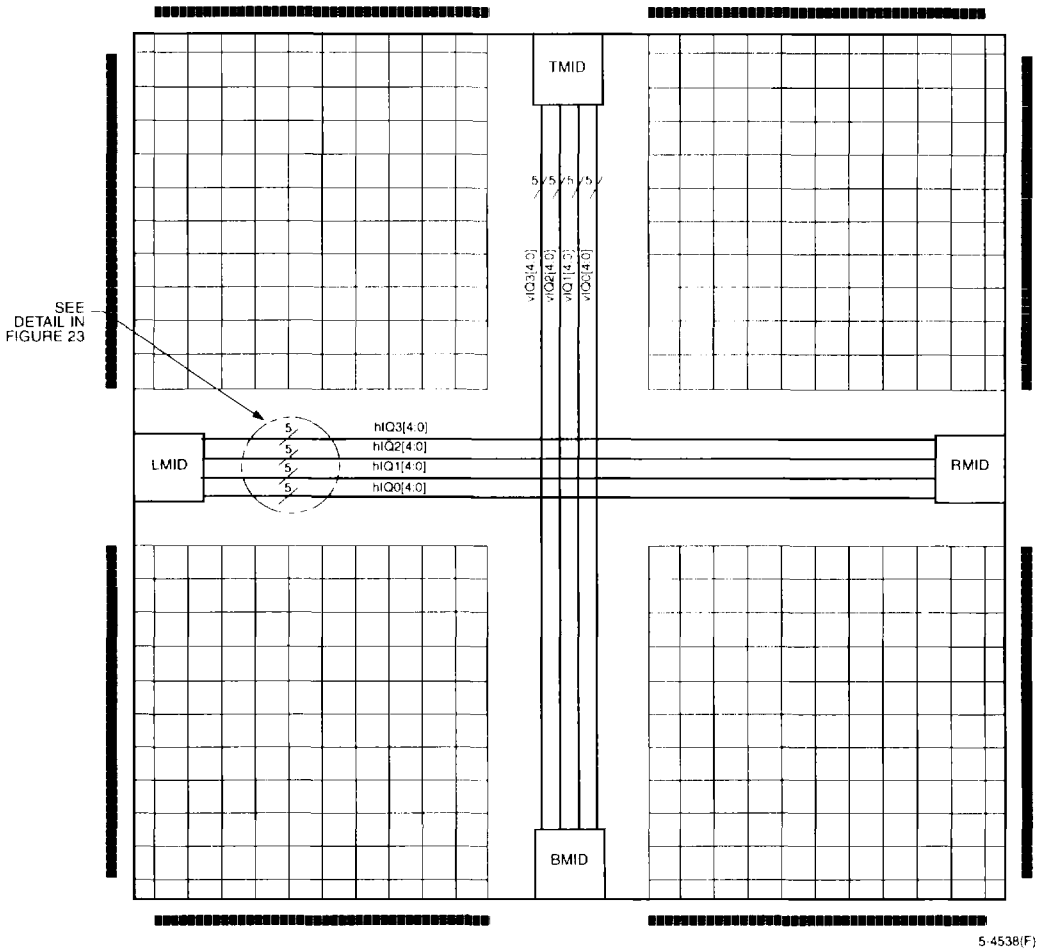

Figure 22. Interquad Routing

Interquad Routing (continued)

In the hIQ block in Figure 23, the xH R-nodes from one quadrant connect through a CIP to its counterpart in the opposite quadrant, creating a path that spans the PLC array. Since a passive CIP is used to connect the two xH R-nodes, a 3-state signal can be routed on the two xH R-nodes in the opposite quadrants, and then they can be connected through this CIP.

2

In the hIQ block, the 20 hIQ R-nodes span the array in a horizontal direction. The 20 hIQ R-nodes consist of four groups of five R-nodes each. To effectively route

nibble-wide buses, each of these sets of five R-nodes can connect to only one of the bits of the nibble for both the xH and xL. For example, hIQ0 R-nodes can only connect to the xH0 and xL0 R-nodes, and the hIQ1 R-nodes can connect only to the xH1 and xL1 R-nodes, etc. Buffers are provided for routing signals from the xH and xL R-nodes onto the hIQ R-nodes and from the hIQ R-nodes onto the xH and xL R-nodes. Therefore, a connection from one quadrant to another can be made using only two xH R-nodes (one in each quadrant) and one interquad R-node.

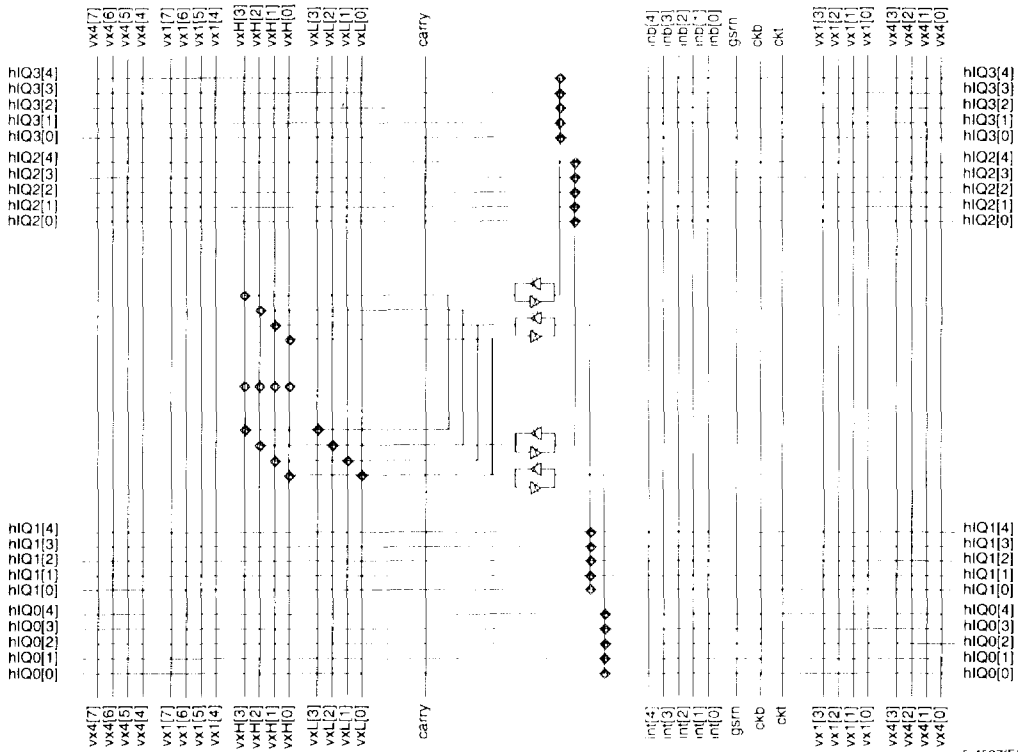

5 4537(F)

Figure 23. hIQ Block Detail

Interquad Routing (continued)

ATT2C40 Subquad Routing

In the ORCA ATT2C40, each quadrant of the device is split into smaller arrays of PLCs called subquads. Each of these subquads is made of a 4 x 4 array of PLCs (for a total of 16 per subquadrant), except at the outer edges of array, which have less than 16 PLCs per subquad. New routing resources, called subquad R-nodes, have been added between each adjacent pair of subquads to enhance the routability of the ATT2C40. A portion of the center of the ATT2C40 array is shown in Figure 24, including the subquad blocks containing a 4 x 4 array of PLCs, the interquad routing R-nodes, and the subquad routing R-nodes.

All of the inter-PLC routing resources discussed previously continue to be routed between a PLC and its adjacent PLC, even if the two adjacent PLCs are in different subquad blocks. Since the PLC routing has not been modified for the ATT2C40 architecture, this means that all of the same routing connections are possible for the ATT2C40 as for any other ORCA 2C Series device. In this way, the ATT2C40 is upwardly compatible when compared with the other 2C Series devices. As the inter-PLC routing runs between subquad blocks, it crosses the new subquad R-nodes. When this happens, CIPs are used to connect the subquad R-nodes to the x4 and/or the xH R-nodes which lie along the other axis of the PLC array.

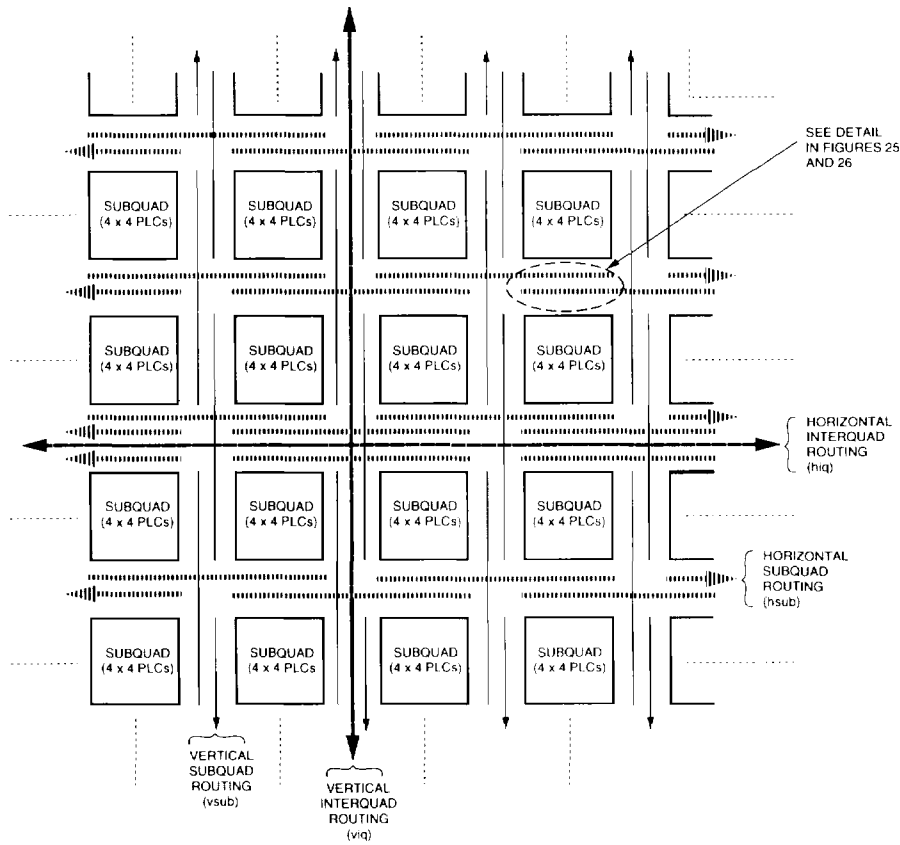

5-4200(C)

Figure 24. Subquad Blocks and Subquad Routing

Interquad Routing (continued)

The x4 and xH R-nodes make the only connections to the subquad R-nodes; therefore, the array remains symmetrical and homogeneous. Since each subquad is made from a 4 x 4 array of PLCs, the distance between sets of subquad R-nodes is four PLCs, which is also the distance between the breaks of the x4 R-nodes. Therefore, each x4 R-node will cross exactly one set of subquad R-nodes. Since all x4 R-nodes make the same connections to the subquad R-nodes that they cross, all x4 R-nodes in the array have the same connectivity, and the symmetry of the routing is preserved. Since all xH R-nodes cross the same number of subquad blocks, the symmetry is maintained for the xH R-nodes as well.

The new subquad R-nodes travel a length of eight PLCs (seven PLCs on the outside edge) before they are broken. Unlike other inter-PLC R-nodes, they cannot be connected end-to-end. As shown in Figure 24, some of the horizontal (vertical) subquad R-nodes have connectivity to the subquad to the left of (above) the current subquad, while others have connectivity to the subquad to the right (below). This allows connections to/from the current subquad from/to the PLCs in all subquads that surround it.

Between all subquads, including in the center of the array, there are three groups of subquad R-nodes where each group contains four R-nodes. Figure 25 shows the connectivity of these three groups of subquad R-nodes (hsub) to the vx4 and vxH R-nodes running between a vertical pair of PLCs. Between each vertical pair of subquad blocks, four of the blocks shown in Figure 25 are used, one for each pair of vertical PLCs.

The first two groups, depicted as A and B, have connectivity to only one of the two sets of x4 R-nodes between pairs of PLCs. Since they are very lightly loaded, they are very fast. The third group, C, connects to both groups of x4 R-nodes between pairs of PLCs, as well as all of the xH R-nodes between pairs of PLCs, providing high flexibility. The connectivity for the vertical subquad routing (vsub) is the same as described above for the horizontal subquad routing, when rotated onto the other axis.

At the center row and column of each quadrant, a fourth group of subquad R-nodes has been added. These subquad R-nodes only have connectivity to the xH R-nodes. The xH R-nodes are also broken at this point, which means that each xH R-node travels one-half of the quadrant (i.e., one-quarter of the device) before it is broken by a CIP. Since the xH R-nodes can be connected end-to-end, the resulting line can be

either one-quarter, one-half, three-quarters, or the entire length of the array. The connectivity of the xH R-nodes and this fourth group of subquad R-nodes, indicated as D, are detailed in Figure 26. Again, the connectivity for the vertical subquad routing (vsub) is the same as the horizontal subquad routing, when rotated onto the other axis.

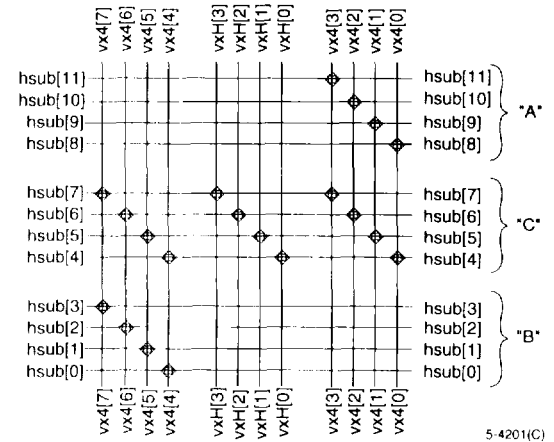

Figure 25. Horizontal Subquad Routing Connectivity

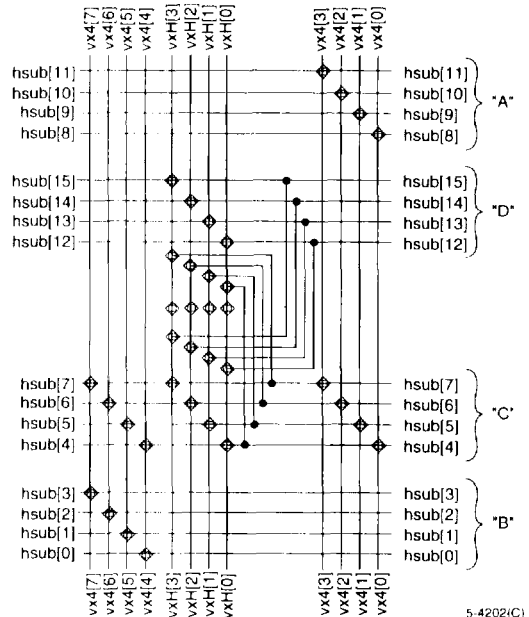
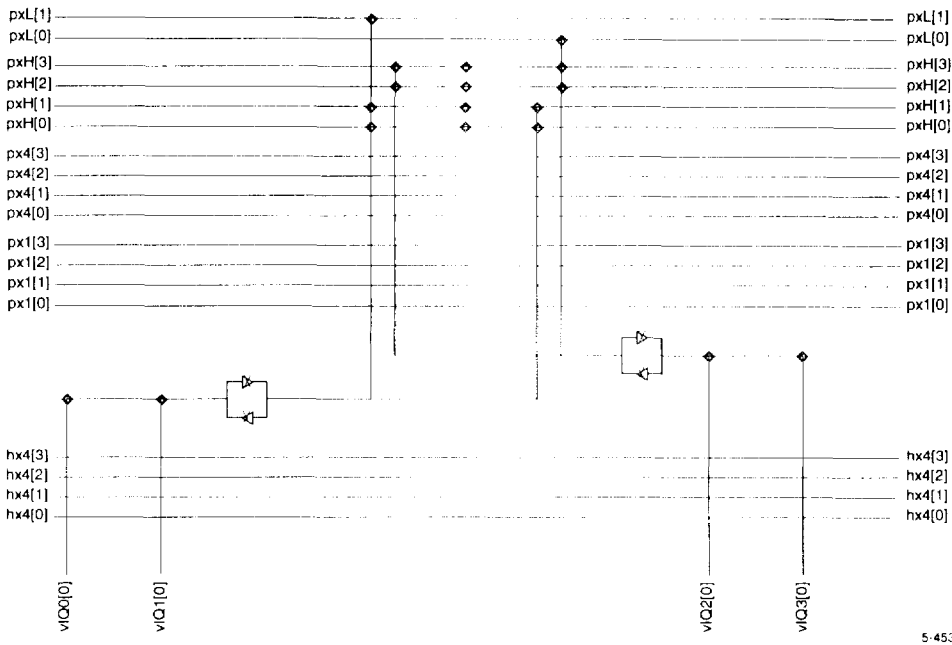

Figure 26. Horizontal Subquad Routing Connectivity (Half Quad)

Interquad Routing (continued)



5-4539(F)

Figure 27. Top (TMID) Routing

PIC Interquad (MID) Routing

Between the PICs in each quadrant, there is also connectivity between the PIC routing and the interquad routing. These blocks are called LMID (left), TMID (top), RMID (right), and BMID (bottom). The TMID routing is shown in Figure 27. As with the hiQ and viQ blocks, the only connectivity to the PIC routing is to the global pxH and pxL R-nodes.

The pxH R-nodes from the one quadrant can be connected through a CIP to its counterpart in the opposite quadrant, providing a path that spans the array of PICs. Since a passive CIP is used to connect the two pxH R-nodes, a 3-state signal can be routed on the two pxH R-nodes in the opposite quadrants, and then connected through this CIP. As with the hiQ and viQ blocks, CIPs and buffers allow nibble-wide connections between the interquad R-nodes, the xH R-nodes, and the xL R-nodes.

Programmable Corner Cells

Programmable Routing

The programmable corner cell (PCC) contains the circuitry to connect the routing of the two PICs in each corner of the device. The PIC px1 and px2 R-nodes are directly connected together from one PIC to another. The PIC pxL R-nodes are connected from one block to another through tridirectional buffers. Four CIPs in each corner connect the four pxH R-nodes from each side of the device.

Special-Purpose Functions

In addition to routing functions, special-purpose functions are located in each FPGA corner. The upper-left PCC contains connections to the boundary-scan logic. The upper-right PCC contains connections to the read-back logic and the connectivity to the global 3-state signal (*ts_all*). The lower-left PCC contains connections to the internal oscillator.

The lower-right PCC contains connections to the start-up and global reset logic. During configuration, the **RESET** input pad always initiates a configuration abort, as described in the FPGA States of Operation section. After configuration, the global set/reset signal (*gsrn*) can either be disabled (the default), directly connected to the **RESET** input pad, or sourced by a lower-right corner signal. If the **RESET** input pad is not used as a global reset after configuration, this pad can be used as a normal input pad. During start-up, the release of the global set/reset, the release of the I/Os, and the release of the external **DONE** signal can each be timed individually based upon the start-up clock. The start-up clock can come from **CCLK** or it can be routed into the start-up block using the lower-right corner routing resources. More details on start-up can be found in the FPGA States of Operation section.

Clock Distribution Network

The *ORCA 2C* series clock distribution scheme uses primary and secondary clocks. This provides the system designer with additional flexibility in assigning clock input pins.

One advantage is that board-level clock traces routed to the FPGA are shorter. On a PC board, the added length of high-speed clock traces routed to dedicated clock input pins can significantly increase the parasitic impedances. The primary advantage of the *ORCA* clock distribution is the availability of a large number of clocks, since all I/O pins are configurable as clocks.

Primary Clock

The primary clock distribution is shown in Figure 28. If the clock signal is from an I/O pad, it can be driven onto a clock R-node. The clock R-nodes do not provide clock signals directly to the PFU; they act as clock spines from which clocks are branched to xL R-nodes. The xL R-nodes then feed the clocks to PFUs. A multiplexer in each PLC is used to transition from the clock spine to the branch.

For a clock spine in the horizontal direction, the inputs into the multiplexer are the two R-nodes from the left and right PICs (*ckl* and *ckr*) and the local clock R-node from the perpendicular direction (*hck*). This signal is then buffered and driven onto one of the vertical xL R-nodes, forming the branches. The same structure is used for a clock spine in the vertical direction. In this case, the multiplexer selects from R-nodes from the top and bottom PICs (*ckt*, *ckb*, and *vck*) and drives the signal onto one of the horizontal xL R-nodes.

Figure 28 illustrates the distribution of the low-skew primary clock to a large number of loads using a main spine and branches. Each row (column) has two dedicated clock R-nodes originating from PICs on opposite sides of the array. The clock is input from the pads to the dedicated clock R-node *ckt* to form the clock spine (see Figure 28, Detail A). From the clock spine, net branches are routed using horizontal xL lines. Clocks into PLCs are tapped from the xL R-nodes, as shown in Figure 28, Detail B.

Clock Distribution Network (continued)

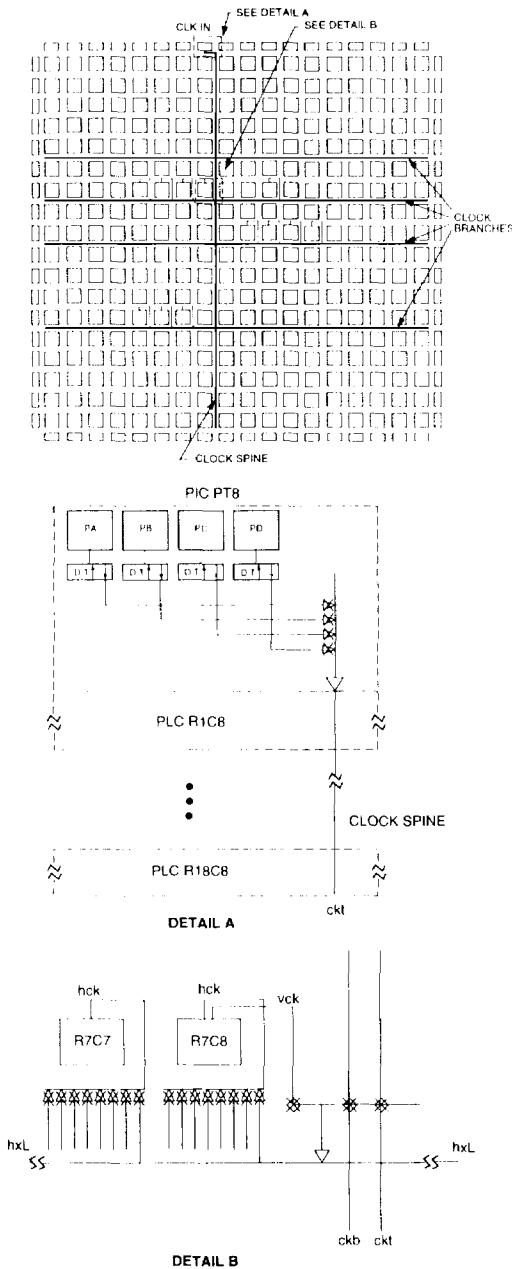

Figure 28. Primary Clock Distribution

Secondary Clock

There are times when a primary clock is either not available or not desired, and a secondary clock is needed. For example:

- Only one input pad per PIC can be placed on the clock routing. If a second input pad in a given PIC requires global signal routing, a secondary clock route must be used.
- Since there is only one branch driver in each PLC for either direction (vertical and horizontal), both clock R-nodes in a particular row or column (ckl and ckr, for example) cannot drive a branch. Therefore, two clocks should not be placed into I/O pads in PICs on the opposite sides of the same row or column if global clocks are to be used.
- Since the clock R-nodes can only be driven from input pads, internally generated clocks should use secondary clock routing.

Figure 29 illustrates the secondary clock distribution. If the clock signal originates from either the left or right side of the FPGA, it can be routed through the TRIDI buffers in the PIC onto one of the adjacent PLC's horizontal xL R-nodes. If the clock signal originates from the top or bottom of the FPGA, the vertical xL R-nodes are used for routing. In either case, an xL R-node is used as the clock spine. In the same manner, if a clock is only going to be used in one quadrant, the xH R-nodes can be used as a clock spine. The routing of the clock spine from the input pads to the vxL (vxH) using the BIDIs (BIDIHs) is shown in Figure 29, Detail A.

In each PLC, a low-skew connection through a long line driver can be used to connect a horizontal xL R-node to a vertical xL R-node or vice versa. As shown in Figure 29, Detail B, this is used to route the branches from the clock spine. If the clock spine is a vertical xL R-node, then the branches are horizontal xL R-nodes and vice versa. The clock is then routed into each PLC from the xL R-node clock branches.

5.4480(C)2C

Clock Distribution Network (continued)

To minimize skew, the PLC clock input for all PLCs must be connected to the branch xL R-nodes, not the spine xL R-node. Even in PLCs where the clock is routed from the spine to the branches, the clock should be routed back into the PLC from the clock branch.

If the clock is to drive only a limited number of loads, the PFUs can be connected directly to the clock spine. In this case, all flip-flops driven by the clock must be located in the same row or column.

2

Alternatively, the clock can be routed from the spine to the branches by using the BIDs instead of the long line drivers. This results in added delay in the clock net, but the clock skew is approximately equal to the clock routed using the long line drivers. This method can be used to create a clock that is used in only one quadrant. The xH R-nodes act as a clock spine, which is then routed to perpendicular xH R-nodes (the branches) using the BIDIHs.

Clock signals, such as the output of a counter, can also be generated in PLCs and routed onto an xL R-node, which then acts as a clock spine. Although the clock can be generated in any PLC, it is recommended that the clock be located as close to the center of the FPGA as possible to minimize clock skew.

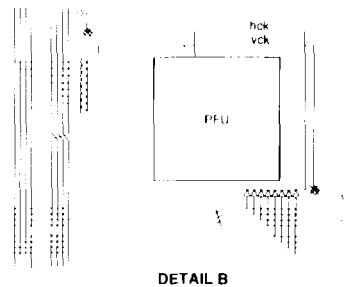
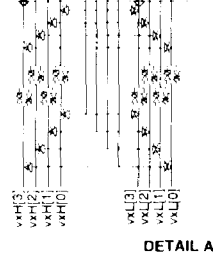
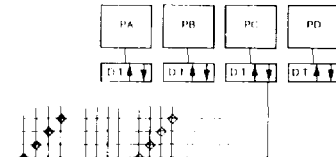
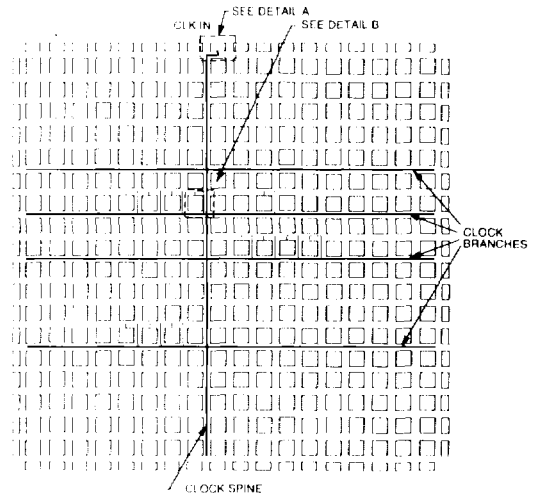

5-4481(C)2C

Figure 29. Secondary Clock Distribution

FPGA States of Operation

Prior to becoming operational, the FPGA goes through a sequence of states, including initialization, configuration, and start-up. This section discusses these three states. Figure 30 outlines the FPGA states.

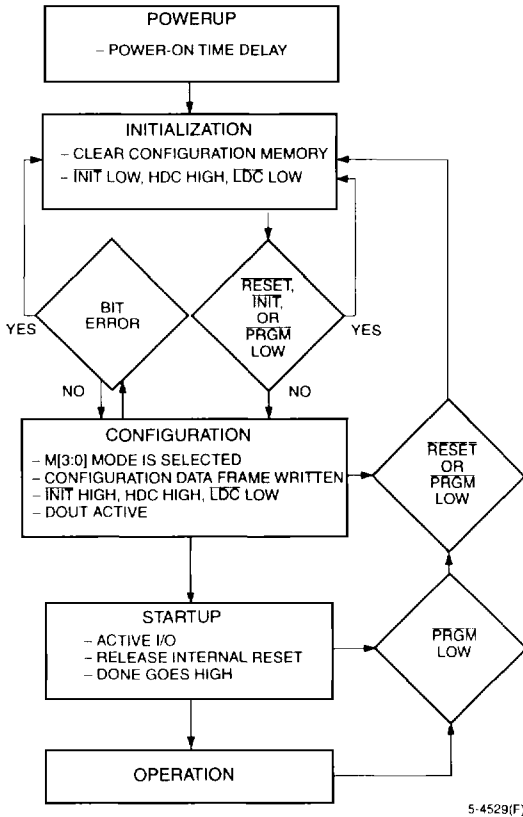

Figure 30. FPGA States of Operation

Initialization

Upon powerup, the device goes through an initialization process. First, an internal power-on-reset circuit is triggered when power is applied. When VDD reaches the voltage at which portions of the FPGA begin to operate (2.5 V to 3 V), the I/Os are configured based on the configuration mode, as determined by the mode select inputs M[2:0]. A time-out delay is initiated when VDD reaches between 3.0 V and 4.0 V to allow the power supply voltage to stabilize. The INIT and DONE outputs are low. At powerup, if VDD does not rise from 2.0 V to VDD in less than 25 ms, the user should delay configuration by inputting a low into INIT, PRGM, or RESET until VDD is greater than the recommended minimum operating voltage (4.75 V for commercial devices).

At the end of initialization, the default configuration option is that the configuration RAM is written to a low state. This prevents shorts prior to configuration. As a configuration option, after the first configuration (i.e., at reconfiguration), the user can reconfigure without clearing the internal configuration RAM first.

The active-low, open-drain initialization signal INIT is released and must be pulled high by an external resistor when initialization is complete. To synchronize the configuration of multiple FPGAs, one or more INIT pins should be wire-ANDed. If INIT is held low by one or more FPGAs or an external device, the FPGA remains in the initialization state. INIT can be used to signal that the FPGAs are not yet initialized. After INIT goes high for two internal clock cycles, the mode lines are sampled and the FPGA enters the configuration state.

The high during configuration (HDC), low during configuration (LDC), and DONE signals are active outputs in the FPGA's initialization and configuration states. HDC, LDC, and DONE can be used to provide control of external logic signals such as reset, bus enable, or PROM enable during configuration. For parallel master configuration modes, these signals provide PROM enable control and allow the data pins to be shared with user logic signals.

If configuration has begun, an assertion of RESET or PRGM initiates an abort, returning the FPGA to the initialization state. The PRGM and RESET pins must be pulled back high before the FPGA will enter the configuration state. During the start-up and operating states, only the assertion of PRGM causes a reconfiguration.

FPGA States of Operation (continued)

In the master configuration modes, the FPGA is the source of configuration clock (CCLK). In this mode, the initialization state is extended to ensure that, in daisy-chain operation, all daisy-chained slave devices are ready. Independent of differences in clock rates, master mode devices remain in the initialization state an additional six internal clock cycles after INIT goes high.

2

When configuration is initiated, a counter in the FPGA is set to 0 and begins to count configuration clock cycles applied to the FPGA. As each configuration data frame is supplied to the FPGA, it is internally assembled into data words. Each data word is loaded into the internal configuration memory. The configuration loading process is complete when the internal length count equals the loaded length count in the length count field, and the required end of configuration frame is written.

All I/Os operate as TTL inputs during configuration. All I/Os that are not used during the configuration process are 3-stated with internal pull-ups. During configuration, the PLC latch/FFs are held set/reset and the internal BIDI buffers are 3-stated. The TRIDIs in the PICs are not 3-stated. The combinatorial logic begins to function as the FPGA is configured. Figure 31 shows the general waveform of the initialization, configuration, and start-up states.

Configuration

The ORCA Series FPGA functionality is determined by the state of internal configuration RAM. This configuration RAM can be loaded in a number of different modes. In these configuration modes, the FPGA can act as a master or a slave of other devices in the system. The decision as to which configuration mode to use is a system design issue. The next section discusses configuration in detail, including the configuration data format and the configuration modes used to load the configuration data in the FPGA.

Start-Up

After configuration, the FPGA enters the start-up phase. This phase is the transition between the configuration and operational states.

This begins when the number of CCLKs received after INIT goes high is equal to the value of the length count field in the configuration frame and when the end of configuration frame has been written. The system design issue in the start-up phase is to ensure the user I/Os become active without inadvertently activating devices in the system or causing bus contention. A second system design concern is the timing of the release of global set/reset of the PLC latches/FFs.

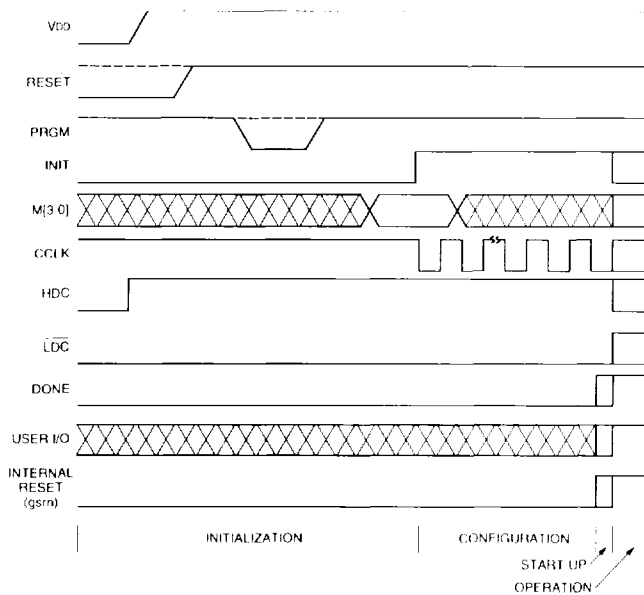

5-4482(C)2C

Figure 31. Initialization/Configuration/Start-Up Waveforms

FPGA States of Operation (continued)

There are configuration options which control the relative timing of three events: DONE going high, release of the set/reset of internal FFs, and user I/Os becoming active. Figure 32 shows the start-up timing for both the ORCA and ATT3000 Series FPGAs. The system designer determines the relative timing of the I/Os becoming active, DONE going high, and the release of the set/reset of internal FFs. In the ORCA Series FPGA, the three events can occur in any arbitrary sequence. This means that they can occur before or after each other, or they can occur simultaneously. The default is for DONE to go high first. This allows configuration sources to be disconnected so that there is no bus contention when the I/Os become active in later cycles. The FFs are set/reset one cycle after DONE goes high so that operation begins in a known state. The DONE output is an open drain and may include an optional internal pull-up resistor to accommodate wired ANDing. The open-drain DONE outputs from multiple FPGAs can be ANDed and used as an active-high ready signal, an active-low PROM enable, or a reset to other portions of the system.

There is also a synchronous start-up mode where start-up does not begin until DONE goes high. The enabling of the FPGA outputs and the set/reset of the internal flip-flops can be triggered or delayed from the rising edge of DONE. Start-up can be delayed by holding the DONE signal low in the synchronous start-up mode. If the DONE signals of multiple FPGAs are tied together, with all in the synchronous start-up mode, start-up does not begin until all of the FPGAs are configured. Normally, the three events are triggered by CCLK. As a configuration option, the three events can be triggered by a user clock, UCLK. This allows start-up to be synchronized by a known system clock. When the user clock option is enabled, the user can still hold DONE low to delay start-up. This allows the synchronization of the start-up of multiple FPGAs. In addition to controlling the FPGA during start-up, additional start-up techniques to avoid contention include using isolation devices between the FPGA and other circuits in the system, reassigning I/O locations, and maintaining I/Os as 3-stated outputs until contentions are resolved.

Reconfiguration

To reconfigure the FPGA when the device is operating in the system, a low pulse is input into PRGM. The configuration data in the FPGA is cleared, and the I/Os not used for configuration are 3-stated. The FPGA then samples the mode select inputs and begins reconfiguration. When reconfiguration is complete, DONE is released, allowing it to be pulled high.

Lucent Technologies Inc.

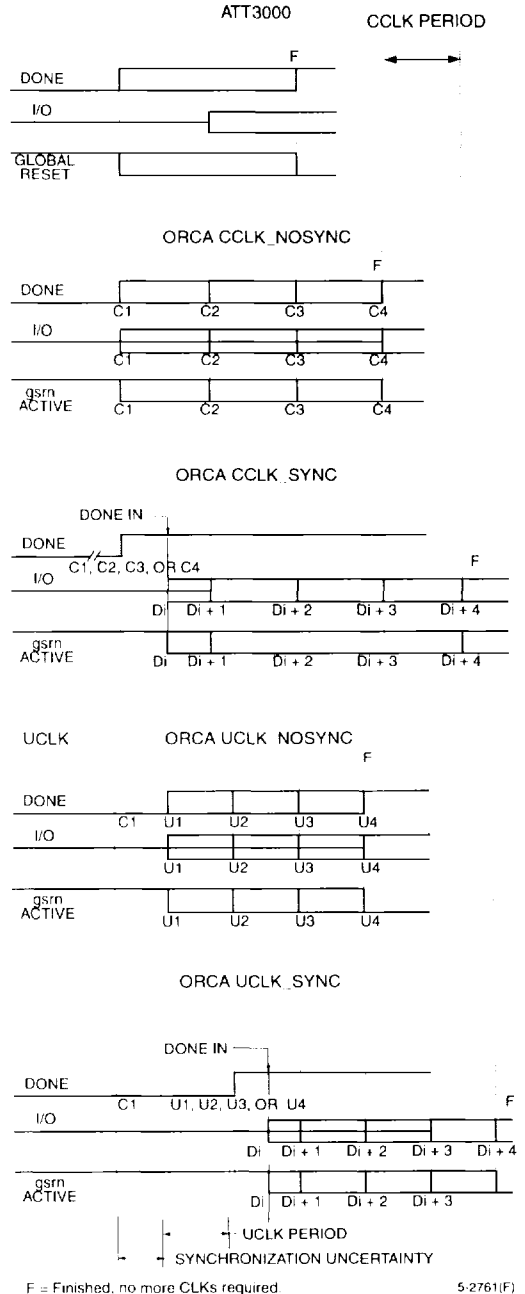

Figure 32. Start-Up Waveform

Configuration Data Format

This section discusses using the *ORCA* Foundry Development System to generate configuration RAM data and then provides the details of the configuration frame format.

Using *ORCA* Foundry to Generate Configuration RAM Data

2

The configuration data defines the I/O functionality, logic, and interconnections. The bit stream is generated by the development system. The bit stream created by the bit stream generation tool is a series of 1s and 0s used to write the FPGA configuration RAM. The bit stream can be loaded into the FPGA using one of the configuration modes discussed later. In the bit stream generator, the designer selects options which affect the FPGA's functionality. Using the output of bit stream generator, *circuit.bit*, the development system's download tool can load the configuration data into the *ORCA* series FPGA evaluation board from a PC or workstation. Alternatively, a user can program a PROM (such as the ATT1700 Series Serial ROMs or standard EPROMs) and load the FPGA from the PROM. The development system's PROM programming tool produces a file in *.mks* or *.exo* format.

Configuration Data Frame

A detailed description of the frame format is shown in Figure 33. The header frame begins with a series of 1s and a preamble of 0010, followed by a 24-bit length count field representing the total number of configuration clocks needed to complete the loading of the FPGAs. Following the header frame is an optional ID frame. This frame contains data used to determine if the bit stream is being loaded to the correct type of *ORCA* FPGA (e.g., is a bit stream generated for an ATT2C15 actually being sent to an ATT2C15?). It has a secondary function of optionally enabling the parity checking logic for the rest of the data frames.

The configuration data frames follow, with each frame starting with a 0 start bit and ending with three or more 1 stop bits. Following the start bit of each frame are four control bits: program bit, set to 1 if this is a data frame; compress bit, set to 1 if this is a compressed frame; and the *opar* and *epar* parity bits, to be discussed in the Bit Stream Error Checking section. An 11-bit address field (that determines which column in the FPGA is to be written) is followed by alignment and write control bits. For uncompressed frames, the data bits needed to write one column in the FPGA are next. For compressed frames, the data bits from the previous frame are sent to a different FPGA column, as specified by the new address bits; therefore, new data bits are not required. When configuration of the current FPGA is finished, an end-of-configuration frame (where the program bit is set to 0) is sent to the FPGA. The length and number of data frames and information about the PROM size for the 2C series FPGAs are given in Table 6.

Configuration Data Format (continued)

Table 6. Configuration Frame Size

Device	2C04	2C06	2C08	2C10	2C12	2C15	2C26	2C40
# of Frames	480	568	656	744	832	920	1096	1378
Data Bits/Frame	110	130	150	170	190	210	250	316
Configuration Data (# of frames x # of data bits/frame)	52,800	73,840	98,400	126,480	158,080	193,200	274,000	435,448
Maximum Total # Bits/Frame (align bits, 1 write bit, 8 stop bits)	136	160	176	200	216	240	280	344
Maximum Configuration Data (# bits x # of frames)	65,280	90,880	115,456	148,800	179,712	220,800	306,880	474,032
Maximum PROM Size (bits) (add 48-bit header, ID frame, and 40-bit end of configuration frame)	65,504	91,128	115,720	149,088	180,016	221,128	307,248	474,464

The data frames for all the 2C series devices are given in Table 7. An alignment field is required in the slave parallel mode for the uncompressed format. The alignment field (shown by [A]) is a series of 0s: five for the 2C06, 2C10, 2C15, and 2C26; three for the 2C40; and one for the 2C04, 2C08, and 2C12. The alignment field is not required in any other mode.

Table 7. Configuration Data Frames

ATT2C04	
Uncompressed	010 opar epar [addr10:0] [A]1[Data109:0]111
Compressed	011 opar epar [addr10:0] 111
ATT2C06	
Uncompressed	010 opar epar [addr10:0] [A]1[Data129:0]111
Compressed	011 opar epar [addr10:0] 111
ATT2C08	
Uncompressed	010 opar epar [addr10:0] [A]1[Data149:0]111
Compressed	011 opar epar [addr10:0] 111
ATT2C10	
Uncompressed	010 opar epar [addr10:0] [A]1[Data169:0]111
Compressed	011 opar epar [addr10:0] 111
ATT2C12	
Uncompressed	010 opar epar [addr10:0] [A]1[Data189:0]111
Compressed	011 opar epar [addr10:0] 111
ATT2C15	
Uncompressed	010 opar epar [addr10:0] [A]1[Data209:0]111
Compressed	011 opar epar [addr10:0] 111
ATT2C26	
Uncompressed	010 opar epar [addr10:0] [A]1[Data249:0]111
Compressed	011 opar epar [addr10:0] 111
ATT2C40	
Uncompressed	010 opar epar [addr10:0] [A]1[Data315:0]111
Compressed	011 opar epar [addr10:0] 111

Configuration Data Format (continued)

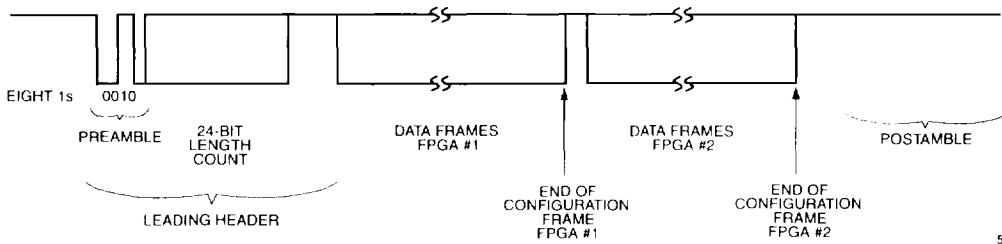

5-4530(F)

Figure 33. Serial Configuration Data Format

Header	11111111	Leading header — 4 bits minimum dummy bits
	0010	Preamble
	24-Bit Length Count	Configuration frame length
	1111	Trailing header — 4 bits minimum dummy bits
ID Frame (Optional)	0	Frame start
	P—1	Must be set to 1 to indicate data frame
	C—0	Must be set to 0 to indicate uncompressed
	Opar, Epar	Frame parity bits
	Addr[10:0] = 1111111111	ID frame address
	Prty_En	Set to 1 to enable parity
	Reserved [42:0]	Reserved bits set to 0
	ID	20-bit part ID
Configuration Data Frame (repeated for each data frame)	111	Three or more stop bits (high) to separate frames
	0	Frame start
	P—1 or 0	1 indicates data frame; 0 indicates all frames are written
	C—1 or 0	Uncompressed — 0 indicates data and address are supplied; Compressed — 1 indicates only address is supplied
	Opar, Epar	Frame parity bits
	Addr[10:0]	Column address in FPGA to be written
	A	Alignment bit (different number of 0s needed for each part)
	1	Write bit — used in uncompressed data frame
End of Configuration	Data Bits	Needed only in an uncompressed data frame
	111	One or more stop bits (high) to separate frames
End of Configuration	0010011111111111	16 bits—00 indicates all frames are written
Postamble	111111	Additional 1s

Note: For slave parallel mode, the byte containing the preamble must be 11110010. The number of leading header dummy bits must be $(n \cdot 8) + 4$, where n is any nonnegative integer and the number of trailing dummy bits must be $(n \cdot 8)$, where n is any positive integer. The number of stop bits/frame for slave parallel mode must be $(x \cdot 8)$, where x is a positive integer. Note also that the bit stream generator tool supplies a bit stream which is compatible with all configuration modes, including slave parallel mode.

Figure 34. Configuration Frame Format and Contents

Bit Stream Error Checking

There are three different types of bit stream error checking performed in the ORCA 2C FPGAs: ID frame, frame alignment, and parity checking.

An optional ID data frame can be sent to a specified address in the FPGA. This ID frame contains a unique code for the part it was generated for which is compared within the FPGA. Any differences are flagged as an ID error.

Every data frame in the FPGA begins with a start bit set to 0 and three or more stop bits set to 1. If any of the three previous bits were a 0 when a start bit is encountered, it is flagged as a frame alignment error.

Parity checking is also done on the FPGA for each frame, if it has been enabled by setting the `prty_en` bit to 1 in the ID frame. Two parity bits, `opar` and `epar`, are used to check the parity of bits in alternating bit positions to even parity in each data frame. If an odd number of ones is found for either the even bits (starting with the start bit) or the odd bits (starting with the program bit), then a parity error is flagged.

When any of the three possible errors occur, the FPGA is forced into the INIT state, forcing `INIT` low. The FPGA will remain in this state until either the `RESET` or `PRGM` pins are asserted.

FPGA Configuration Modes

There are eight methods for configuring the FPGA. Seven of the configuration modes are selected on the M0, M1, and M2 inputs. The eighth configuration mode is accessed through the boundary-scan interface. A fourth input, M3, is used to select the frequency of the internal oscillator, which is the source for CCLK in some configuration modes. The nominal frequencies of the internal oscillator are 1.25 MHz and 10 MHz. The 1.25 MHz frequency is selected when the M3 input is unconnected or driven to a high state.

There are three basic FPGA configuration modes: master, slave, and peripheral. The configuration data can be transmitted to the FPGA serially or in parallel bytes. As a master, the FPGA provides the control signals out to strobe data in. As a slave device, a clock is generated externally and provided into CCLK. In the peripheral mode, the FPGA acts as a microprocessor peripheral. Table 8 lists the functions of the configuration mode pins.

Table 8. Configuration Modes

M2	M1	M0	CCLK	Configuration Mode	Data
0	0	0	Output	Master	Serial
0	0	1	Input	Slave Parallel	Parallel
0	1	0	Reserved		
0	1	1	Input	Sync Peripheral	Parallel
1	0	0	Output	Master (up)	Parallel
1	0	1	Output	Async Peripheral	Parallel
1	1	0	Output	Master (down)	Parallel
1	1	1	Input	Slave	Serial

Master Parallel Mode

The master parallel configuration mode is generally used to interface to industry-standard byte-wide memory such as the 2764 and larger EPROMs. Figure 35 provides the connections for master parallel mode. The FPGA outputs an 18-bit address on A[17:0] to memory and reads one byte of configuration data on the rising edge of RCLK. The parallel bytes are internally serialized starting with the least significant bit, D0.

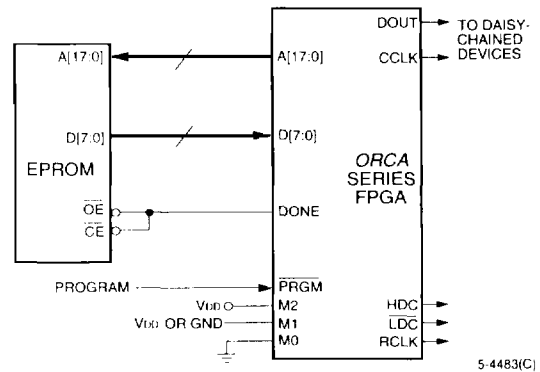

Figure 35. Master Parallel Configuration Schematic

There are two parallel master modes: master up and master down. In master up, the starting memory address is 00000 Hex and the FPGA increments the address for each byte loaded. In master down, the starting memory address is 3FFFF Hex and the FPGA decrements the address.

One master mode FPGA can interface to the memory and provide configuration data on DOUT to additional FPGAs in a daisy chain. The configuration data on DOUT is provided synchronously with the falling edge of CCLK. The frequency of the CCLK output is eight times that of RCLK.

FPGA Configuration Modes (continued)

Master Serial Mode

2

In the master serial mode, the FPGA loads the configuration data from an external serial ROM. The configuration data is either loaded automatically at start-up or on a PRGM command to reconfigure. The ATT1700 and ATT1700A Series can be used to configure the FPGA in the master serial mode. This provides a simple four-pin interface in an eight-pin package. The ATT1736, ATT1765, and ATT17128 serial ROMs store 32K, 64K, and 128K bits, respectively.

Configuration in the master serial mode can be done at powerup and/or upon a configure command. The system or the FPGA must activate the serial ROM's RESET/OE and CE inputs. At powerup, the FPGA and serial ROM each contain internal power-on reset circuitry that allows the FPGA to be configured without the system providing an external signal. The power-on reset circuitry causes the serial ROM's internal address pointer to be reset. After powerup, the FPGA automatically enters its initialization phase.

The serial ROM/FPGA interface used depends on such factors as the availability of a system reset pulse, availability of an intelligent host to generate a configure command, whether a single serial ROM is used or multiple serial ROMs are cascaded, whether the serial ROM contains a single or multiple configuration programs, etc. Because of differing system requirements and capabilities, a single FPGA/serial ROM interface is generally not appropriate for all applications.

Data is read in the FPGA sequentially from the serial ROM. The DATA output from the serial ROM is connected directly into the DIN input of the FPGA. The CCLK output from the FPGA is connected to the CLOCK input of the serial ROM. During the configuration process, CCLK clocks one data bit on each rising edge.

Since the data and clock are direct connects, the FPGA/serial ROM design task is to use the system or FPGA to enable the RESET/OE and CE of the serial ROM(s). There are several methods for enabling the serial ROM's RESET/OE and CE inputs. The serial ROM's RESET/OE is programmable to function with RESET active-high and OE active-low or RESET active-low and OE active-high.

In Figure 36, serial ROMs are cascaded to configure multiple daisy-chained FPGAs. The host generates a 500 ns low pulse into the FPGA's PRGM input. The FPGA's INIT input is connected to the serial ROMs' RESET/OE input, which has been programmed to

function with RESET active-low and OE active-high. The FPGA DONE is routed to the CE pin. The low on DONE enables the serial ROMs. At the completion of configuration, the high on the FPGA's DONE disables the serial ROM.

Serial ROMs can also be cascaded to support the configuration of multiple FPGAs or to load a single FPGA when configuration data requirements exceed the capacity of a single serial ROM. After the last bit from the first serial ROM is read, the serial ROM outputs CE low and 3-states the DATA output. The next serial ROM recognizes the low on CE input and outputs configuration data on the DATA output. After configuration is complete, the FPGA's DONE output into CE disables the serial ROMs.

This FPGA/serial ROM interface is not used in applications in which a serial ROM stores multiple configuration programs. In these applications, the next configuration program to be loaded is stored at the ROM location that follows the last address for the previous configuration program. The reason the interface in Figure 36 will not work in this application is that the low output on the INIT signal would reset the serial ROM address pointer, causing the first configuration to be reloaded.

In some applications, there can be contention on the FPGA's DIN pin. During configuration, DIN receives configuration data, and after configuration, it is a user I/O. If there is contention, an early DONE at start-up (selected in ORCA Foundry) may correct the problem. An alternative is to use LDC to drive the serial ROM's CE pin. In order to reduce noise, it is generally better to run the master serial configuration at 1.25 MHz (M3 pin tied high), rather than 10 MHz, if possible.

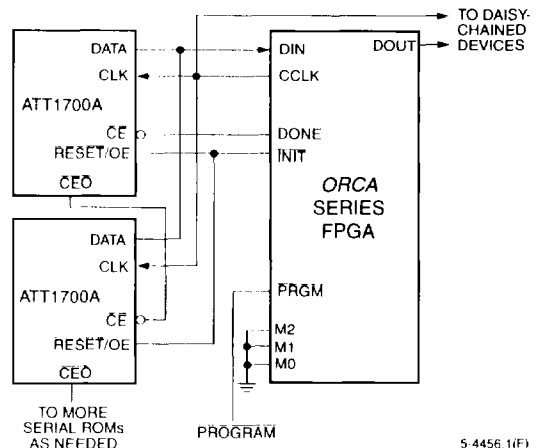

Figure 36. Master Serial Configuration Schematic

FPGA Configuration Modes (continued)

Asynchronous Peripheral Mode

Figure 37 shows the connections needed for the asynchronous peripheral mode. In this mode, the FPGA system interface is similar to that of a microprocessor-peripheral interface. The microprocessor generates the control signals to write an 8-bit byte into the FPGA. The FPGA control inputs include active-low CS0 and active-high CS1 chip selects and a write WR input. The chip selects can be cycled or maintained at a static level during the configuration cycle. Each byte of data is written into the FPGA's D[7:0] input pins.

The FPGA provides a RDY/BSY status output to indicate that another byte can be loaded. A low on RDY/BSY indicates that the double-buffered hold/shift registers are not ready to receive data. The shortest time RDY/BSY is low occurs when a byte is loaded into the hold register and the shift register is empty, in which case the byte is immediately transferred to the shift register. The longest time for RDY/BSY to remain low occurs when a byte is loaded into the holding register and the shift register has just started shifting configuration data into configuration RAM. The RDY/BSY status is also available on the D7 pin by enabling the chip selects, setting WR high, and setting RD low.

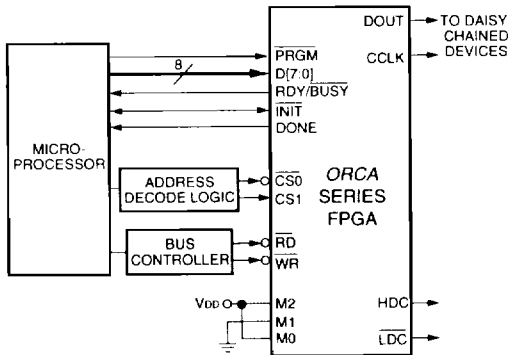

5-4484(C)

Figure 37. Asynchronous Peripheral Configuration Schematic

Synchronous Peripheral Mode

In the synchronous peripheral mode, byte-wide data is input into D[7:0] on the rising edge of the CCLK input. The first data byte is clocked in on the second CCLK after INIT goes high. Subsequent data bytes are clocked in on every eighth rising edge of CCLK. The RDY/BSY signal is an output which acts as an acknowledge. RDY/BSY goes high one CCLK after data is clocked and, after one CCLK cycle, returns low. The process repeats until all of the data is loaded into the FPGA. The data begins shifting on DOUT 1.5 cycles after it is loaded in parallel. It requires additional CCLKs after the last byte is loaded to complete the shifting. Figure 38 shows the connections for synchronous peripheral mode.

As with master modes, the peripheral modes can be used as the lead FPGA for a daisy chain of slave FPGAs.

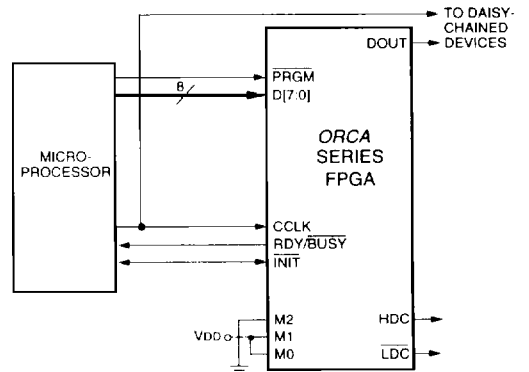

5-4486(C)

Figure 38. Synchronous Peripheral Configuration Schematic

FPGA Configuration Modes (continued)

Slave Serial Mode

The slave serial mode is primarily used when multiple FPGAs are configured in a daisy chain. The serial slave mode is also used on the FPGA evaluation board which interfaces to the download cable. A device in the slave serial mode can be used as the lead device in a daisy chain. Figure 39 shows the connections for the slave serial configuration mode.

2

The configuration data is provided into the FPGA's DIN input synchronous with the configuration clock CCLK input. After the FPGA has loaded its configuration data, it retransmits the incoming configuration data on DOUT. CCLK is routed into all slave serial mode devices in parallel.

Multiple slave FPGAs can be loaded with identical configurations simultaneously. This is done by loading the configuration data into the DIN inputs in parallel.

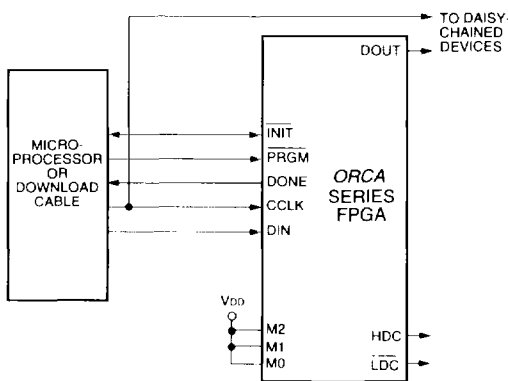

5-4485(C)

Figure 39. Slave Serial Configuration Schematic

Slave Parallel Mode

The slave parallel mode is essentially the same as the slave serial mode except that 8 bits of data are input on pins D[7:0] for each CCLK cycle. Due to 8 bits of data being input per CCLK cycle, the DOUT pin does not contain a valid bit stream for slave parallel mode. As a result, the lead device cannot be used in the slave parallel mode in a daisy-chain configuration.

Figure 40 is a schematic of the connections for the slave parallel configuration mode. WR and CS0 are active-low chip select signals, and CS1 is an active-high chip select signal. These chip selects allow the user to configure multiple FPGAs in slave parallel mode using an 8-bit data bus common to all of the FPGAs. These chip selects can then be used to select the FPGA(s) to be configured with a given bit stream, but once an FPGA has been selected, it cannot be deselected until it has been completely programmed.

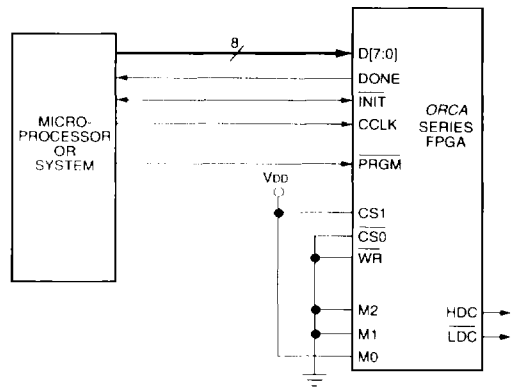

5-4487(C)

Figure 40. Slave Parallel Configuration Schematic

FPGA Configuration Modes (continued)

Daisy Chain

Multiple FPGAs can be configured by using a daisy chain of the FPGAs. Daisy chaining uses a lead FPGA and one or more FPGAs configured in slave serial mode. The lead FPGA can be configured in any mode except slave parallel mode. (Daisy chaining is not available with the boundary-scan ram_w instruction, discussed later.)

All daisy-chained FPGAs are connected in series. Each FPGA reads and shifts the preamble and length count in on positive CCLK and out on negative CCLK edges.

An upstream FPGA which has received the preamble and length count outputs a high on DOUT until it has received the appropriate number of data frames so that downstream FPGAs do not receive frame start bits (0s). After loading and retransmitting the preamble and length count to a daisy chain of slave devices, the lead device loads its configuration data frames. The loading of configuration data continues after the lead device has received its configuration data if its internal frame bit counter has not reached the length count. When the configuration RAM is full and the number of bits received is less than the length count field, the FPGA shifts any additional data out on DOUT.

The configuration data is read into DIN of slave devices on the positive edge of CCLK, and shifted out DOUT on the negative edge of CCLK. Figure 41 shows the connections for loading multiple FPGAs in a daisy-chain configuration.

The generation of CCLK for the daisy-chained devices which are in slave serial mode differs depending on the configuration mode of the lead device. A master parallel mode device uses its internal timing generator to produce an internal CCLK at eight times its memory address rate (RCLK). The asynchronous peripheral mode device outputs eight CCLKs for each write cycle. If the lead device is configured in either synchronous peripheral or a slave mode, CCLK is routed to the lead device and to all of the daisy-chained devices.

The development system can create a composite configuration bit stream for configuring daisy-chained FPGAs. The frame format is a preamble, a length count for the total bit stream, multiple concatenated data frames, an end-of-configuration frame per device, a postamble, and an additional fill bit per device in the serial chain.

As seen in Figure 41, the INIT pins for all of the FPGAs are connected together. This is required to guarantee that powerup and initialization will work correctly. In general, the DONE pins for all of the FPGAs are also connected together as shown to guarantee that all of the FPGAs enter the start-up state simultaneously. This may not be required, depending upon the start-up sequence desired.

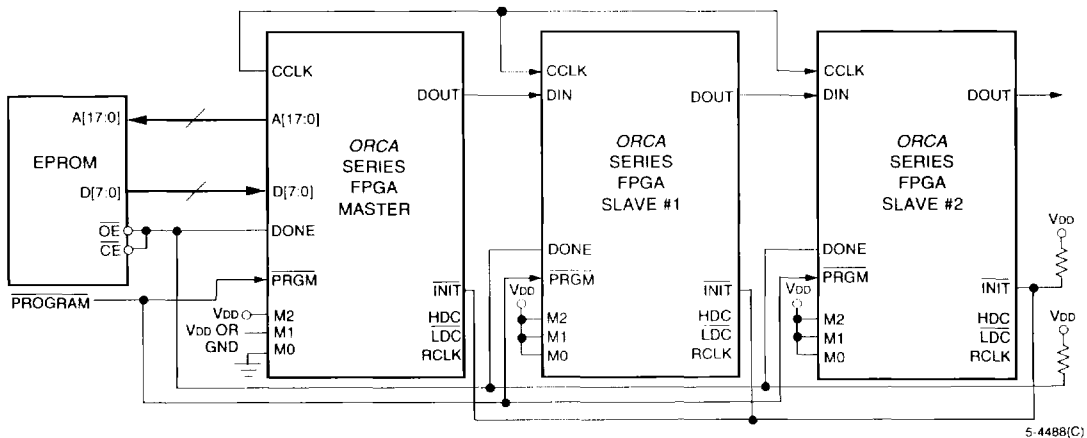

Figure 41. Daisy-Chain Configuration Schematic

Readback

Readback is used to read back the configuration data and, optionally, the state of the PFU outputs. A readback operation can be done while the FPGA is in normal system operation. The readback operation cannot be daisy chained. To use readback, the user selects options in the bit stream generator in the *ORCA* Foundry development system.

2

Table 9 provides readback options selected in the bit stream generator tool. The table provides the number of times that the configuration data can be read back. This is intended primarily to give the user control over the security of the FPGA's configuration program. The user can prohibit readback (0), allow a single readback (1), or allow unrestricted readback (U).

The pins used for readback are readback data (RD_DATA), read configuration (RD_CFGN), and configuration clock (CCLK). A readback operation is initiated by a high-to-low transition on RD_CFGN. The RD_CFGN input must remain low during the readback operation. The readback operation can be restarted at frame 0 by setting the RD_CFGN pin high, applying at least two rising edges of CCLK, and then applying RD_CFGN low again. One bit of data is shifted out on RD_DATA on the rising edge of CCLK. The first start bit of the readback frame is transmitted out on the first rising edge of CCLK after RD_CFGN is input low.

It should be noted that the RD_DATA output pin is also used as the dedicated boundary-scan output pin, TDO. If this pin is being used as TDO, the RD_DATA output from readback can be routed internally to any other pin desired. The RD_CFGN input pin is also used to control the global 3-state (ts_all) function. Before and during configuration, the ts_all signal is always driven by the RD_CFGN input and readback is disabled. After configuration, the selection as to whether this input drives the readback or global 3-state function is determined by a set of bit stream options. If used as the RD_CFGN input for readback, the internal ts_all input can be routed internally to be driven by any input pin.

The readback frame contains the configuration data and the state of the internal logic. During readback, the value of all five PFU outputs can be captured. The following options are allowed when doing a capture of the PFU outputs.

1. Do not capture data (the data written to the RAMs, usually 0, will be read back).
2. Capture data upon entering readback.
3. Capture data based upon a configurable signal internal to the FPGA. If this signal is tied to logic 0, capture RAMs are written continuously, which is equivalent to ATT3000 Series capture.
4. Capture data on either options 2 or 3 above.

The readback frame has a similar, but not identical, format to the configuration frame. This eases a bitwise comparison between the configuration and readback data. The readback data is not inverted. Every data frame has one low start bit and one high stop bit. The preamble, including the length count field, is not part of the readback frame. The readback frame contains states in locations not used in the configuration. These locations need to be masked out when comparing the configuration and readback frames. The development system optionally provides a readback bit stream to compare to readback data from the FPGA.

Table 9. Readback Options

Option	Function
0	Inhibit Readback
1	Allow One Readback Only
U	Allow Unrestricted Number of Readbacks

Boundary Scan

The increasing complexity of integrated circuits (ICs) and IC packages has increased the difficulty of testing printed-circuit boards (PCBs). To address this testing problem, the IEEE standard 1149.1 - 1990 (IEEE Standard Test Access Port and Boundary-Scan Architecture) is implemented in the ORCA series of FPGAs. It allows users to efficiently test the interconnection between integrated circuits on a PCB as well as test the integrated circuit itself. The IEEE 1149.1 standard is a well-defined protocol that ensures interoperability among boundary-scan (BSCAN) equipped devices from different vendors.

The IEEE 1149.1 standard defines a test access port (TAP) that consists of a four-pin interface with an optional reset pin for boundary-scan testing of integrated circuits in a system. The ORCA Series FPGA provides four interface pins: test data in (TDI), test mode select (TMS), test clock (TCK), and test data out (TDO). The PRGM pin used to reconfigure the device also resets the boundary-scan logic.

The user test host serially loads test commands and test data into the FPGA through these pins to drive outputs and examine inputs. In the configuration shown in Figure 42, where boundary scan is used to test ICs, test data is transmitted serially into TDI of the first BSCAN device (U1), through TDO/TDI connections between BSCAN devices (U2 and U3), and out TDO of the last BSCAN device (U4). In this configuration, the TMS and TCK signals are routed to all boundary-scan ICs in parallel so that all boundary-scan components operate in the same state. In other configurations, multiple scan paths are used instead of a single ring. When multiple scan paths are used, each ring is independently controlled by its own TMS and TCK signals.

Figure 43 provides a system interface for components used in the boundary-scan testing of PCBs. The three major components shown are the test host, boundary-scan support circuit, and the devices under test (DUTs). The DUTs shown here are ORCA Series FPGAs with dedicated boundary-scan circuitry. The test host is normally one of the following: automatic test equipment (ATE), a workstation, a PC, or a microprocessor.

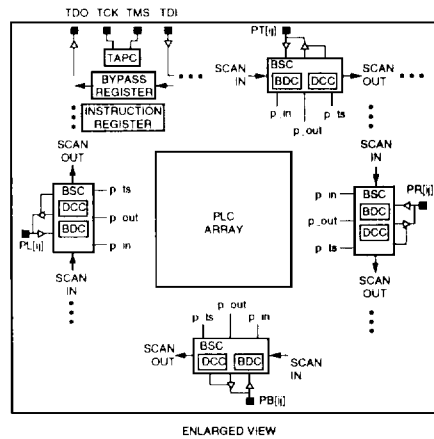
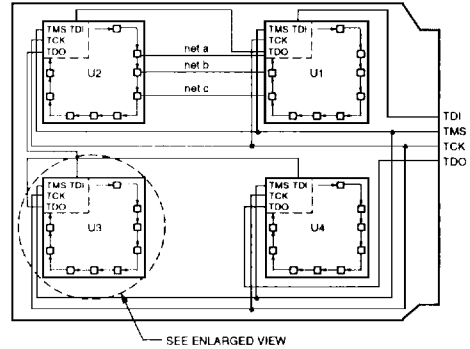

Fig.34 a(M)

Key: BSC = boundary-scan cell, BDC = bidirectional data cell, and DCC = data control cell.

Figure 42. Printed-Circuit Board with Boundary-Scan Circuitry

Boundary Scan (continued)

2

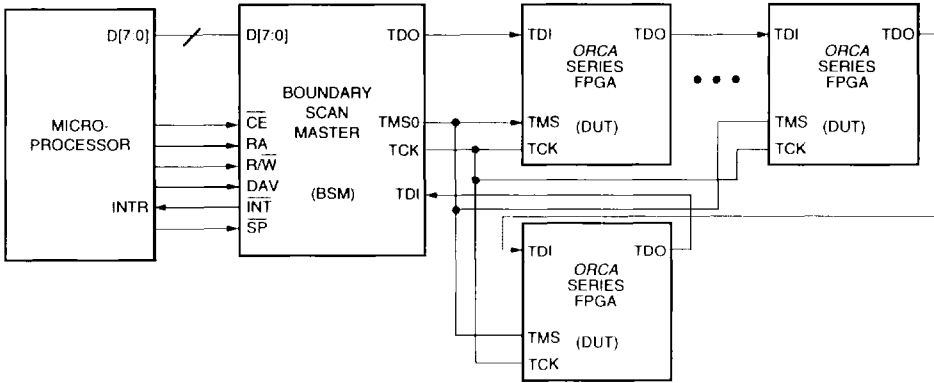

1BSI(C)

Figure 43. Boundary-Scan Interface

The boundary-scan support circuit shown in Figure 43 is the Lucent 497AA Boundary-Scan Master (BSM). The BSM off-loads tasks from the test host to increase test throughput. To interface between the test host and the DUTs, the BSM has a general microprocessor interface and provides parallel-to-serial/serial-to-parallel conversion, as well as three 8K data buffers. The BSM also increases test throughput with a dedicated automatic test pattern generator and with compression of the test response with a signature analysis register. The PC-based Lucent boundary-scan test card/software allows a user to quickly prototype a boundary-scan test setup.

Boundary-Scan Instructions

The ORCA Series boundary-scan circuitry is used for three mandatory IEEE 1149.1 tests (EXTEST, SAMPLE/PRELOAD, BYPASS) and four Lucent-defined instructions. The 3-bit wide instruction register supports the eight instructions listed in Table 10.

Table 10. Boundary-Scan Instructions

Code	Instruction
000	EXTEST
001	PLC Scan Ring 1
010	RAM Write (RAM_W)
011	Reserved
100	SAMPLE/PRELOAD
101	PLC Scan Ring 2
110	RAM Read (RAM_R)
111	BYPASS

The external test (EXTEST) instruction allows the interconnections between ICs in a system to be tested for opens and stuck-at faults. If an EXTEST instruction is performed for the system shown in Figure 42, the connections between U1 and U2 (shown by nets a, b, and c) can be tested by driving a value onto the given nets from one device and then determining whether the same value is seen at the other device. This is determined by shifting 2 bits of data for each pin (one for the output value and one for the 3-state value) through the BSR until each one aligns to the appropriate pin. Then, based upon the value of the 3-state signal, either the I/O pad is driven to the value given in the BSR, or the BSR is updated with the input value from the I/O pad, which allows it to be shifted out TDO.

The SAMPLE instruction is useful for system debugging and fault diagnosis by allowing the data at the FPGA's I/Os to be observed during normal operation. The data for all of the I/Os is captured simultaneously into the BSR, allowing them to be shifted-out TDO to the test host. Since each I/O buffer in the PICs is bidirectional, two pieces of data are captured for each I/O pad: the value at the I/O pad and the value of the 3-state control signal.

There are four Lucent-defined instructions. The PLC scan rings 1 and 2 (PSR1, PSR2) allow user-defined internal scan paths using the PLC latches/FFs. The RAM Write Enable (RAM_W) instruction allows the user to serially configure the FPGA through TDI. The RAM_Read Enable (RAM_R) allows the user to read back RAM contents on TDO after configuration.

Boundary Scan (continued)

ORCA Boundary-Scan Circuitry

The ORCA Series boundary-scan circuitry includes a test access port controller (TAPC), instruction register (IR), boundary-scan register (BSR), and bypass register. It also includes circuitry to support the four Lucent-defined instructions.

Figure 44 shows a functional diagram of the boundary-scan circuitry that is implemented in the ORCA series. The input pins' (TMS, TCK, and TDI) locations vary depending on the part, and the output pin is the dedicated TDO/RD_DATA output pad. Test data in (TDI) is the serial input data. Test mode select (TMS) controls the boundary-scan test access port controller (TAPC). Test clock (TCK) is the test clock on the board.

The BSR is a series connection of boundary-scan cells (BSCs) around the periphery of the IC. Each I/O pad on the FPGA, except for CCLK, DONE, and the boundary-scan pins (TCK, TDI, TMS, and TDO), is included in the BSR. The first BSC in the BSR (connected to TDI) is

located in the first PIC I/O pad on the left of the top side of the FPGA (PTA PIC). The BSR proceeds clockwise around the top, right, bottom, and left sides of the array. The last BSC in the BSR (connected to TDO) is located on the top of the left side of the array (PLA3).

The bypass instruction uses a single FF which resynchronizes test data that is not part of the current scan operation. In a bypass instruction, test data received on TDI is shifted out of the bypass register to TDO. Since the BSR (which requires a two FF delay for each pad) is bypassed, test throughput is increased when devices that are not part of a test operation are bypassed.

The boundary-scan logic is enabled before and during configuration. After configuration, a configuration option determines whether or not boundary-scan logic is used.

The 32-bit boundary-scan identification register contains the manufacturer's ID number, unique part number, and version, but is not implemented in the ORCA series of FPGAs. If boundary scan is not used, TMS, TDI, and TCK become user I/Os, and TDO is 3-stated or used in the readback operation.

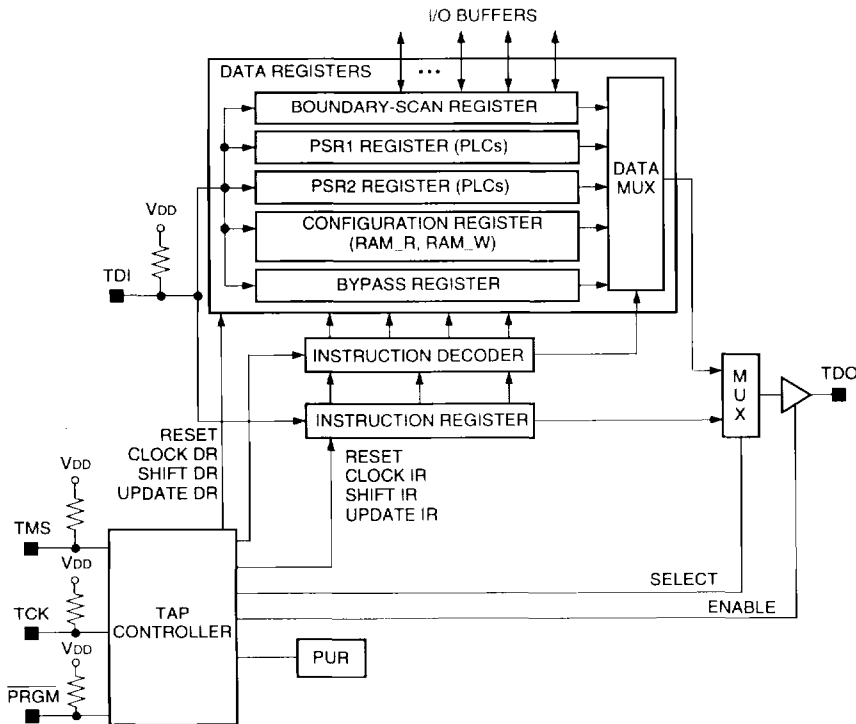

5-2840(C)2C

Figure 44. ORCA Series Boundary-Scan Circuitry Functional Diagram

Boundary Scan (continued)

ORCA Series TAP Controller (TAPC)

The ORCA Series TAP controller (TAPC) is a 1149.1 compatible test access port controller. The 16 JTAG state assignments from the IEEE 1149.1 specification are used. The TAPC is controlled by TCK and TMS. The TAPC states are used for loading the IR to allow three basic functions in testing: providing test stimuli (Update DR), test execution (Run Test/Idle), and obtaining test responses (Capture DR). The TAPC allows the test host to shift in and out both instructions and test data/results. The inputs and outputs of the TAPC are provided in the table below. The outputs are primarily the control signals to the instruction register and the data register.

2

Table 11. TAP Controller Input/Outputs

Symbol	I/O	Function
TMS	I	Test Mode Select
TCK	I	Test Clock
PUR	I	Powerup Reset
PRGM	I	BSCAN Reset
TRESET	O	Test Logic Reset
Select	O	Select IR (High); Select DR (Low)
Enable	O	Test Data Out Enable
Capture DR	O	Capture/Parallel Load DR
Capture IR	O	Capture/Parallel Load IR
Shift DR	O	Shift Data Register
Shift IR	O	Shift Instruction Register
Update DR	O	Update/Parallel Load DR
Update IR	O	Update/Parallel Load IR

The TAPC generates control signals which allow capture, shift, and update operations on the instruction and data registers. In the capture operation, data is loaded into the register. In the shift operation, the captured data is shifted out while new data is shifted in. In the update operation, either the instruction register is loaded for instruction decode, or the boundary-scan register is updated for control of outputs.

The test host generates a test by providing input into the ORCA Series TMS input synchronous with TCK. This sequences the TAPC through states in order to perform the desired function on the instruction register or a data register. Figure 45 provides a diagram of the state transitions for the TAPC. The next state is determined by the TMS input value.

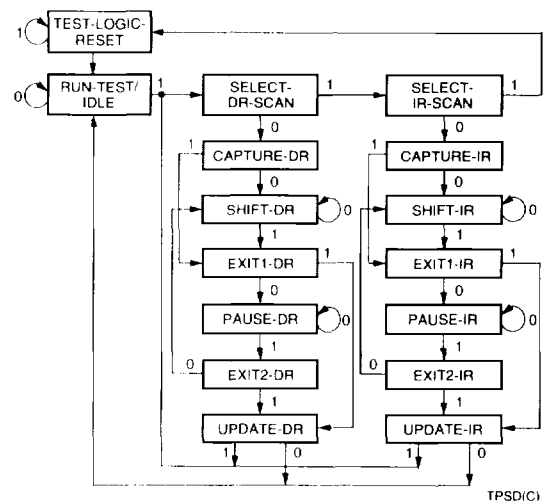

Figure 45. TAP Controller State Transition Diagram

Boundary Scan (continued)

Boundary-Scan Cells

Figure 46 is a diagram of the boundary-scan cell (BSC) in the ORCA series PICs. There are four BSCs in each PIC: one for each pad, except as noted above. The BSCs are connected serially to form the BSR. The BSC controls the functionality of the in, out, and 3-state signals for each pad.

The BSC allows the I/O to function in either the normal or test mode. Normal mode is defined as when an output buffer receives input from the PLC array and provides output at the pad or when an input buffer provides input from the pad to the PLC array. In the test mode, the BSC executes a boundary-scan operation, such as shifting in scan data from an upstream BSC in the BSR, providing test stimuli to the pad, capturing test data at the pad, etc.

The primary functions of the BSC are shifting scan data serially in the BSR and observing input (p_in), output (p_out), and 3-state (p_ts) signals at the pads. The BSC consists of two circuits: the bidirectional data cell is used to access the input and output data, and the

direction control cell is used to access the 3-state value. Both cells consist of a flip-flop used to shift scan data which feeds a flip-flop to control the I/O buffer. The bidirectional data cell is connected serially to the direction control cell to form a boundary-scan shift register.

The TAPC signals (capture, update, shiftn, treset, and TCK) and the MODE signal control the operation of the BSC. The bidirectional data cell is also controlled by the high out/low in (HOLI) signal generated by the direction control cell. When HOLI is low, the bidirectional data cell receives input buffer data into the BSC. When HOLI is high, the BSC is loaded with functional data from the PLC.

The MODE signal is generated from the decode of the instruction register. When the MODE signal is high (EXTEST), the scan data is propagated to the output buffer. When the MODE signal is low (BYPASS or SAMPLE), functional data from the FPGA's internal logic is propagated to the output buffer.

The boundary-scan description language (BSDL) is provided for each device in the ORCA series of FPGAs. The BSDL is generated from a device profile, pinout, and other boundary-scan information.

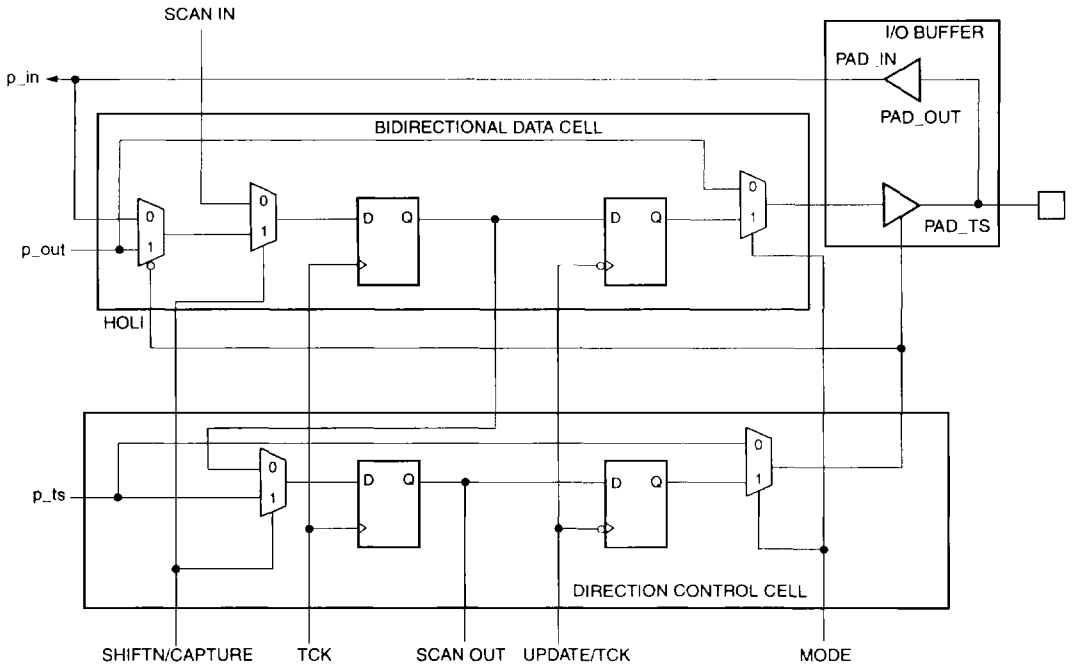

5-2844(F)

Figure 46. Boundary-Scan Cell

Boundary Scan (continued)

2

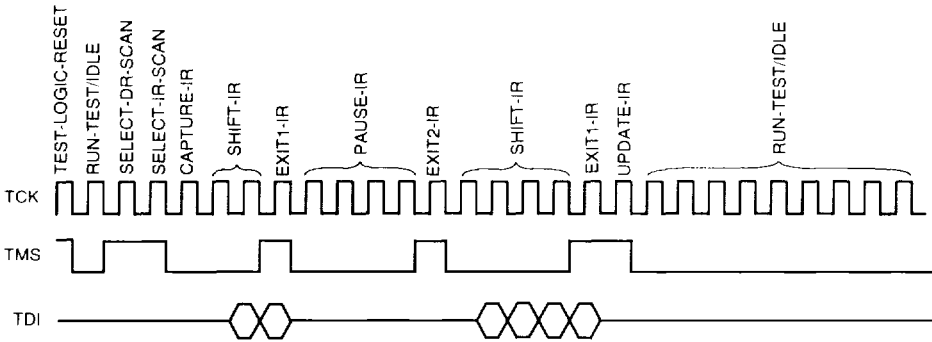

Fig 5.3(C)

Figure 47. Instruction Register Scan Timing Diagram

Boundary-Scan Timing

To ensure race-free operation, data changes on specific clock edges. The TMS and TDI inputs are clocked in on the rising edge of TCK, while changes on TDO occur on the falling edge of TCK. In the execution of an EXTEST instruction, parallel data is output from the BSR to the FPGA pads on the falling edge of TCK. The maximum frequency allowed for TCK is 10 MHz.

Figure 47 shows timing waveforms for an instruction scan operation. The diagram shows the use of TMS to sequence the TAPC through states. The test host (or BSM) changes data on the falling edge of TCK, and it is clocked into the DUT on the rising edge.

ORCA Timing Characteristics

To define speed grades, the ORCA Series part number designation (see Table 45) uses a single-digit number to designate a speed grade. This number is not related to any single ac parameter. Higher numbers indicate a faster set of timing parameters. The actual speed sorting is based on testing the delay in a path consisting of an input buffer, combinatorial delay through all PLCs in a row, and an output buffer. Other tests are then done to verify other delay parameters, such as routing delays, setup times to FFs, etc.

The most accurate timing characteristics are reported by the timing analyzer in the ORCA Foundry Development System. A timing report provided by the development system after layout divides path delays into logic and routing delays. The timing analyzer can also provide logic delays prior to layout. While this allows routing budget estimates, there is wide variance in routing delays associated with different layouts.

The logic timing parameters noted in the Electrical Characteristics section of this data sheet are the same as those in the design tools. In the PFU timing given in Table 30, symbol names are generally a concatenation of the PFU operating mode (as defined in Table 2) and the parameter type. The wildcard character (*) is used in symbol names to indicate that the parameter applies to any sub-LUT. The setup, hold, and propagation delay parameters, defined below, are designated in the symbol name by the SET, HLD, and DEL characters, respectively.

ORCA Timing Characteristics

(continued)

The values given for the parameters are the same as those used during production testing and speed binning of the devices. The junction temperature and supply voltage used to characterize the devices are listed in the delay tables. Actual delays at nominal temperature and voltage for best-case processes can be much better than the values given.

Table 12 and Table 13 provide approximate power supply and junction temperature derating for commercial and industrial devices. The delay values in this data sheet and reported by ORCA Foundry are shown as **1.00** in the tables. The method for determining the maximum junction temperature is defined in the Thermal Characteristics section. Taken cumulatively, the range of parameter values for best-case vs. worst-case processing, supply voltage, and junction temperature can approach 3 to 1.

Table 12. Derating for Commercial Devices

T _J (°C)	Power Supply Voltage		
	4.75 V	5.0 V	5.25 V
0	0.79	0.77	0.75
25	0.83	0.81	0.79
85	1.00	0.97	0.95
100	1.05	1.03	1.00
125	1.14	1.11	1.08

Table 13. Derating for Industrial Devices

T _J (°C)	Power Supply Voltage				
	4.5 V	4.75 V	5.0 V	5.25 V	5.5 V
-40	0.70	0.69	0.67	0.65	0.64
0	0.79	0.77	0.75	0.73	0.72
25	0.83	0.81	0.79	0.77	0.76
85	1.00	0.97	0.95	0.92	0.91
100	1.05	1.02	1.00	0.97	0.95
125	1.14	1.11	1.08	1.05	1.03

In addition to supply voltage, process variation, and operating temperature, circuit and process improvements of the ORCA series FPGAs over time will result in significant improvement of the actual performance over those listed for a speed grade. Even though lower speed grades may still be available, the distribution of yield to timing parameters may be several speed bins higher than that designated on a product brand. Design practices need to consider best-case timing parameters (e.g., delays = 0), as well as worst-case timing.

The routing delays are a function of fan-out and the capacitance associated with the CIPs and metal interconnect in the path. The number of logic elements that can be driven (or fan-out) by PFUs is unlimited, although the delay to reach a valid logic level can exceed timing requirements. It is difficult to make accurate routing delay estimates prior to design compilation based on fan-out. This is because the CAE software may delete redundant logic inserted by the designer to reduce fan-out, and/or it may also automatically reduce fan-out by net splitting.

The waveform test points are given in the Measurement Conditions section of this data sheet. The timing parameters given in the electrical characteristics tables in this data sheet follow industry practices, and the values they reflect are described below.

Propagation Delay — the time between the specified reference points. The delays provided are the worst case of the t_{phh} and t_{pll} delays for noninverting functions, t_{plh} and t_{phl} for inverting functions, and t_{phz} and t_{plz} for 3-state enable.

Setup Time — the interval immediately preceding the transition of a clock or latch enable signal, during which the data must be stable to ensure it is recognized as the intended value.

Hold Time — the interval immediately following the transition of a clock or latch enable signal, during which the data must be held stable to ensure it is recognized as the intended value.

3-state Enable — the time from when a ts[3:0] signal becomes active and the output pad reaches the high-impedance state.

Estimating Power Dissipation

The total operating power dissipated is estimated by summing the standby (IDD_{SB}), internal, and external power dissipated. The internal and external power is the power consumed in the PLCs and PICs, respectively. In general, the standby power is small and may be neglected. The total operating power is as follows:

$$P_T = \Sigma P_{PLC} + \Sigma P_{PIC}$$

The internal operating power is made up of two parts: clock generation and PFU output power. The PFU output power can be estimated based upon the number of PFU outputs switching when driving an average fan-out of two:

$$P_{PFU} = 0.19 \text{ mW/MHz}$$

For each PFU output that switches, 0.19 mW/MHz needs to be multiplied times the frequency (in MHz) that the output switches. Generally, this can be estimated by using one-half the clock rate, multiplied by some activity factor; for example, 20%.

The power dissipated by the clock generation circuitry is based upon three parts: the fixed clock power, the power/clock branch row or column, and the clock power dissipated in each PFU that uses this particular clock. Therefore, the clock power can be calculated for the three parts using the following equations:

2C04 Clock Power

$$P = [0.64 \text{ mW/MHz} + (0.22 \text{ mW/MHz} - \text{Branch}) (\# \text{ Branches}) + (0.025 \text{ mW/MHz} - \text{PFU}) (\# \text{ PFUs})] f_{CLK}$$

For a quick estimate, the worst-case (typical circuit) 2C04 Clock Power \approx 4.1 mW/MHz.

2C06 Clock Power

$$P = [0.65 \text{ mW/MHz} + (0.26 \text{ mW/MHz} - \text{Branch}) (\# \text{ Branches}) + (0.025 \text{ mW/MHz} - \text{PFU}) (\# \text{ PFUs})] f_{CLK}$$

For a quick estimate, the worst-case (typical circuit) 2C06 Clock Power \approx 5.6 mW/MHz.

2C08 Clock Power

$$P = [0.66 \text{ mW/MHz} + (0.29 \text{ mW/MHz} - \text{Branch}) (\# \text{ Branches}) + (0.025 \text{ mW/MHz} - \text{PFU}) (\# \text{ PFUs})] f_{CLK}$$

For a quick estimate, the worst-case (typical circuit) 2C08 Clock Power \approx 7.2 mW/MHz.

2C10 Clock Power

$$P = [0.67 \text{ mW/MHz} + (0.33 \text{ mW/MHz} - \text{Branch}) (\# \text{ Branches}) + (0.025 \text{ mW/MHz} - \text{PFU}) (\# \text{ PFUs})] f_{CLK}$$

For a quick estimate, the worst-case (typical circuit) 2C10 Clock Power \approx 9.2 mW/MHz.

2C12 Clock Power

$$P = [0.69 \text{ mW/MHz} + (0.37 \text{ mW/MHz} - \text{Branch}) (\# \text{ Branches}) + (0.025 \text{ mW/MHz} - \text{PFU}) (\# \text{ PFUs})] f_{CLK}$$

For a quick estimate, the worst-case (typical circuit) 2C12 Clock Power \approx 11.4 mW/MHz.

2C15 Clock Power

$$P = [0.70 \text{ mW/MHz} + (0.40 \text{ mW/MHz} - \text{Branch}) (\# \text{ Branches}) + (0.025 \text{ mW/MHz} - \text{PFU}) (\# \text{ PFUs})] f_{CLK}$$

For a quick estimate, the worst-case (typical circuit) 2C15 Clock Power \approx 13.7 mW/MHz.

2C26 Clock Power

$$P = [0.71 \text{ mW/MHz} + (0.47 \text{ mW/MHz} - \text{Branch}) (\# \text{ Branches}) + (0.025 \text{ mW/MHz} - \text{PFU}) (\# \text{ PFUs})] f_{CLK}$$

For a quick estimate, the worst-case (typical circuit) 2C26 Clock Power \approx 19.2 mW/MHz.

2C40 Clock Power

$$P = [0.75 \text{ mW/MHz} + (0.57 \text{ mW/MHz} - \text{Branch}) (\# \text{ Branches}) + (0.025 \text{ mW/MHz} - \text{PFU}) (\# \text{ PFUs})] f_{CLK}$$

For a quick estimate, the worst-case (typical circuit) 2C40 Clock Power \approx 29.1 mW/MHz.

The power dissipated in a PIC is the sum of the power dissipated in the four I/Os in the PIC. This consists of power dissipated by inputs and ac power dissipated by outputs. The power dissipated in each I/O depends on whether it is configured as an input, output, or input/output. If an I/O is operating as an output, then there is a power dissipation component for P_{IN}, as well as P_{OUT}. This is because the output feeds back to the input.

Estimating Power Dissipation

(continued)

The power dissipated by a TTL input buffer is estimated as:

$$P_{TTL} = 1.8 \text{ mW} + 0.20 \text{ mW/MHz}$$

The power dissipated by a CMOS input buffer is estimated as:

$$P_{CMOS} = 0.20 \text{ mW/MHz}$$

The ac power dissipation from an output or bidirectional is estimated by the following:

$$P_{OUT} = (C_L + 9 \text{ pF}) \times V_{DD}^2 \times F \text{ Watts}$$

where the unit for C_L is farads, and the unit for F is Hz.

As an example of estimating power dissipation, suppose that a fully utilized 2C15 has an average of three outputs for each of the 400 PFUs, that all 20 clock branches are used, that 150 of the 400 PFUs have FFs clocked at 40 MHz, and that the PFU outputs have an average activity factor of 20%.

Twenty TTL-configured inputs, 20 CMOS-configured inputs, 32 outputs driving 30 pF loads, and 16 bidirectional I/Os driving 50 pF loads are also generated from the 40 MHz clock with an average activity factor of 20%. The worst-case power dissipation is estimated as follows:

$$\begin{aligned} P_{PFU} &= 400 \times 3 (0.19 \text{ mW/MHz} \times 20 \text{ MHz} \times 20\%) \\ &= 912 \text{ mW} \end{aligned}$$

$$\begin{aligned} P_{CLK} &= [0.70 \text{ mW/MHz} + (0.40 \text{ mW/MHz} - \text{Branch}) \\ &\quad (20 \text{ Branches}) \\ &\quad + (0.025 \text{ mW/MHz} - \text{PFU}) (150 \text{ PFUs}) [40 \text{ MHz}]] \\ &= 498 \text{ mW} \end{aligned}$$

$$\begin{aligned} P_{TTL} &= 20 \times [1.8 \text{ mW} + (0.20 \text{ mW/MHz} \times 20 \text{ MHz} \times \\ &\quad 20\%)] \\ &= 52 \text{ mW} \end{aligned}$$

$$\begin{aligned} P_{CMOS} &= 20 \times [0.20 \text{ mW} \times 20 \text{ MHz} \times 20\%] \\ &= 16 \text{ mW} \end{aligned}$$

$$\begin{aligned} P_{OUT} &= 30 \times [(30 \text{ pF} + 9 \text{ pF}) \times 5.5252 \times 20 \text{ MHz} \times 20\%] \\ &= 129 \text{ mW} \end{aligned}$$

$$\begin{aligned} P_{BID} &= 16 \times [(50 \text{ pF} + 9 \text{ pF}) \times 5.5252 \times 20 \text{ MHz} \times 20\%] \\ &= 104 \text{ mW} \end{aligned}$$

$$TOTAL = 1.71 \text{ W}$$

Pin Information

Table 14. Pin Descriptions

Symbol	I/O	Description
Dedicated Pins		
VDD	—	Positive power supply.
GND	—	Ground supply.
RESET	I	During configuration, RESET forces the restart of configuration and a pull-up is enabled. After configuration, RESET can be used as a general FPGA input or as a direct input, which causes all PLC latches/FFs to be asynchronously set/reset.
CCLK	I	In the master and asynchronous peripheral modes, CCLK is an output which strobes configuration data in. In the slave or synchronous peripheral mode, CCLK is input synchronous with the data on DIN or D[7:0].
DONE	I/O	DONE is a bidirectional pin with an optional pull-up resistor. As an active-low, open-drain output, it indicates that configuration is complete. As an input, a low level on DONE delays FPGA start-up after configuration.
PRGM	I	PRGM is an active-low input that forces the restart of configuration and resets the boundary-scan circuitry. This pin always has an active pull-up.
RD_CFGN	I	If readback is enabled, after configuration, a high-to-low transition on RD_CFGN initiates a readback of configuration data, including PFU output states, starting with frame address 0. During configuration, this is an active-low input that activates the TS_ALL function and 3-states all the I/O. This same functionality can be selected after configuration as well. This pin always has an active pull-up.
RD_DATA/TDO	O	RD_DATA/TDO is a dual-function pin. If used for readback, RD_DATA provides configuration data out. If used in boundary scan, TDO is test data out.
Special-Purpose Pins		
RDY/BUSY	O	During configuration in peripheral mode, RDY/BUSY indicates another byte can be written to the FPGA. If a read operation is done when the device is selected, the same status is also available on D7 in asynchronous peripheral mode. After configuration, the pin is a user-programmable I/O.
RCLK	O	During the master parallel configuration mode, RCLK is a read output signal to an external memory. This output is not normally used. After configuration, this pin is a user-programmable I/O pin.
DIN	I	During slave serial or master serial configuration modes, DIN accepts serial configuration data synchronous with CCLK. During parallel configuration modes, DIN is the D0 input. During configuration, a pull-up is enabled, and after configuration, this pin is a user-programmable I/O pin.
M0, M1, M2	I	M0—M2 are used to select the configuration mode. See Table 8 for the configuration modes. During configuration, a pull-up is enabled, and after configuration, the pins are user-programmable I/O.
M3	I	M3 is used to select the speed of the internal oscillator during configuration. When M3 is low, the oscillator frequency is 10 MHz. When M3 is high, the oscillator is 1.25 MHz. During configuration, a pull-up is enabled, and after configuration, this pin is a user-programmable I/O pin.

Pin Information (continued)

Table 14. Pin Descriptions (continued)

Symbol	I/O	Description
TDI, TCK, TMS	I	If boundary scan is used, these pins are Test Data In, Test Clock, and Test Mode Select inputs. If boundary scan is not selected, all boundary-scan functions are inhibited once configuration is complete, and these pins are user-programmable I/O pins. Even if boundary scan is not used, either TCK or TMS must be held at logic 1 during configuration. Each pin has a pull-up enabled during configuration.
HDC	O	High During Configuration is output high until configuration is complete. It is used as a control output indicating that configuration is not complete. After configuration, this pin is a user-programmable I/O pin.
LDC	O	Low During Configuration is output low until configuration is complete. It is used as a control output indicating that configuration is not complete. After configuration, this pin is a user-programmable I/O pin.
INIT	I/O	INIT is a bidirectional signal before and during configuration. During configuration, a pull-up is enabled, but an external pull-up resistor is recommended. As an active-low open-drain output, INIT is held low during power stabilization and internal clearing of memory. As an active-low input, INIT holds the FPGA in the wait-state before the start of configuration. After configuration, the pin is a user-programmable I/O pin.
CS0, CS1, WR, RD	I	CS0, CS1, WR, RD are used in the asynchronous peripheral configuration modes. The FPGA is selected when CS0 is low and CS1 is high. When selected, a low on the write strobe, WR, loads the data on D[7:0] inputs into an internal data buffer. WR, CS0, and CS1 are also used as chip selects in the slave parallel mode. A low on RD changes D7 into a status output. As a status indication, a high indicates ready and a low indicates busy. WR and RD should not be used simultaneously. If they are, the write strobe overrides. During configuration, a pull-up is enabled, and after configuration, the pins are user-programmable I/O pins.
A[17:0]	O	During master parallel configuration mode, A[17:0] address the configuration EPROM. During configuration, a pull-up is enabled, and after configuration, the pins are user-programmable I/O pins.
D[7:0]	I	During master parallel, peripheral, and slave parallel configuration modes, D[7:0] receive configuration data and each pin has a pull-up enabled. After configuration, the pins are user-programmable I/O pins.
DOUT	O	During configuration, DOUT is the serial data output that can drive the DIN of daisy-chained slave LCA devices. Data out on DOUT changes on the falling edge of CCLK. After configuration, DOUT is a user-programmable I/O pin.

Pin Information (continued)**Package Compatibility**

The package pinouts are consistent across ORCA Series FPGAs. This allows a designer to select a package based on I/O requirements and change the FPGA without relaying out the printed-circuit board. The change might be to a larger FPGA, if additional functionality is needed, or a smaller FPGA to decrease unit cost.

Table 15 provides the number of user I/Os available for Lucent ORCA Series FPGAs for each available package. Each package has six dedicated configuration pins.

Tables 16—25 provide the package pin and pin function for the ORCA 2C Series FPGAs and packages. The bond pad name is identified in the PIC nomenclature used in the ORCA Foundry design editor.

When the number of FPGA bond pads exceeds the number of package pins, bond pads are unused. When the number of package pins exceeds the number of bond pads, package pins are left unconnected (no connects).

For each package in the 2C Series, Tables 16—25 provide package pin functionality and the bond pad connection. When a package pin is to be left as a no connect for a specific die, it is indicated as a note in the bond pad column for the FPGA. The tables provide no information on unused pads.

Table 15. ORCA 2C Series FPGA I/Os Summary

Device	84-Pin PLCC	100-Pin TQFP	144-Pin TQFP	160-Pin MQFP	208-Pin SQFP/ SQFP- PQ2	240-Pin SQFP/ SQFP- PQ2	256-Pin PBGA	304-Pin SQFP/ SQFP- PQ2	364- Pin CPGA	428-Pin CPGA
ATT2C04										
User I/Os	64	77	114	130	160	—	—	—	—	—
VDD/VSS	14	17	24	24	31	—	—	—	—	—
ATT2C06										
User I/Os	64	77	114	130	171	192	—	—	—	—
VDD/VSS	14	17	24	24	31	42	—	—	—	—
ATT2C08										
User I/Os	64	—	—	130	171	192	221	224	—	—
VDD/VSS	14	—	—	24	31	40	27	46	—	—
ATT2C10										
User I/Os	64	—	—	130	171	192	223	252	—	—
VDD/VSS	14	—	—	24	31	40	27	46	—	—
ATT2C12										
User I/Os	—	—	—	—	171	192	223	252	288	—
VDD/VSS	—	—	—	—	31	42	27	46	38	—
ATT2C15										
User I/Os	—	—	—	—	171	192	—	252	320	—
VDD/VSS	—	—	—	—	31	42	—	46	38	—
ATT2C26										
User I/Os	—	—	—	—	171	192	—	252	—	384
VDD/VSS	—	—	—	—	31	42	—	46	—	38
ATT2C40										
User I/Os	—	—	—	—	171	192	—	252	—	384
VDD/VSS	—	—	—	—	31	42	—	46	—	38

Pin Information (continued)

Table 16. ATT2C04, ATT2C06, ATT2C08, and ATT2C10 84-Pin PLCC Pinout

Pin	2C04 Pad	2C06 Pad	2C08 Pad	2C10 Pad	Function	Pin	2C04 Pad	2C06 Pad	2C08 Pad	2C10 Pad	Function
1	VSS	VSS	VSS	VSS	VSS	43	VSS	VSS	VSS	VSS	VSS
2	PT5A	PT6A	PT7A	PT8A	I/O-D2	44	PB6A	PB7A	PB8A	PB9A	I/O
3	VSS	VSS	VSS	VSS	VSS	45	VSS	VSS	VSS	VSS	VSS
4	PT4D	PT5D	PT6D	PT7D	I/O-D1	46	PB7A	PB8A	PB9A	PB10A	I/O
5	PT4A	PT5A	PT6A	PT7A	I/O-D0/DIN	47	PB7D	PB8D	PB9D	PB10D	I/O
6	PT3A	PT4A	PT5A	PT6A	I/O-DOOUT	48	PB8A	PB9A	PB10A	PB11A	I/O-HDC
7	PT2D	PT3D	PT4D	PT5D	I/O	49	PB9A	PB10A	PB11A	PB12A	I/O-LDC
8	PT2A	PT3A	PT4A	PT4A	I/O-TDI	50	PB9D	PB10D	PB11D	PB13A	I/O
9	PT1D	PT2A	PT3A	PT3A	I/O-TMS	51	PB10A	PB11A	PB12C	PB13D	I/O-INIT
10	PT1A	PT1A	PT1A	PT1A	I/O-TCK	52	PB10D	PB12A	PB13D	PB15D	I/O
11	RD_DATA /TDO	RD_DATA /TDO	RD_DATA /TDO	RD_DATA /TDO	RD_DATA /TDO	53	DONE	DONE	DONE	DONE	DONE
12	VDD	VDD	VDD	VDD	VDD	54	RESET	RESET	RESET	RESET	RESET
13	VSS	VSS	VSS	VSS	VSS	55	PRGM	PRGM	PRGM	PRGM	PRGM
14	PL1C	PL1A	PL2D	PL2D	I/O-A0	56	PR10A	PR12A	PR14A	PR16A	I/O-M0
15	PL1A	PL2A	PL3A	PL3A	I/O-A1	57	PR10D	PR11A	PR12A	PR14A	I/O
16	PL2D	PL3D	PL4D	PL4A	I/O-A2	58	PR9A	PR10A	PR11A	PR13B	I/O-M1
17	PL2A	PL3A	PL4A	PL5A	I/O-A3	59	PR9D	PR10D	PR11D	PR12B	I/O
18	PL3A	PL4A	PL5A	PL6A	I/O-A4	60	PR8A	PR9A	PR10A	PR11A	I/O-M2
19	PL4D	PL5D	PL6D	PL7D	I/O-A5	61	PR7A	PR8A	PR9A	PR10A	I/O-M3
20	PL4A	PL5A	PL6A	PL7A	I/O-A6	62	PR7D	PR8D	PR9D	PR10D	I/O
21	PL5A	PL6A	PL7A	PL8A	I/O-A7	63	PR6A	PR7A	PR8D	PR9D	I/O
22	VDD	VDD	VDD	VDD	VDD	64	VDD	VDD	VDD	VDD	VDD
23	PL6A	PL7A	PL8A	PL9A	I/O-A8	65	PR5A	PR6A	PR7A	PR8A	I/O
24	VSS	VSS	VSS	VSS	VSS	66	VSS	VSS	VSS	VSS	VSS
25	PL7D	PL8D	PL9D	PL10D	I/O-A9	67	PR4A	PR5A	PR6A	PR7A	I/O
26	PL7A	PL8A	PL9A	PL10A	I/O-A10	68	PR4D	PR5D	PR6D	PR7D	I/O
27	PL8A	PL9A	PL10A	PL11A	I/O-A11	69	PR3A	PR4A	PR5A	PR6A	I/O-CS1
28	PL9D	PL10D	PL11D	PL12D	I/O-A12	70	PR2A	PR3A	PR4A	PR5A	I/O-CS0
29	PL9A	PL10A	PL11A	PL13D	I/O-A13	71	PR2D	PR3D	PR4D	PR4D	I/O
30	PL10D	PL11A	PL12A	PL14C	I/O-A14	72	PR1A	PR2A	PR3A	PR3A	I/O-RD
31	PL10A	PL12A	PL14A	PL16A	I/O-A15	73	PR1D	PR1A	PR2A	PR2A	I/O-WR
32	CCLK	CCLK	CCLK	CCLK	CCLK	74	RD_CFGN	RD_CFGN	RD_CFGN	RD_CFGN	RD_CFGN
33	VDD	VDD	VDD	VDD	VDD	75	VDD	VDD	VDD	VDD	VDD
34	VSS	VSS	VSS	VSS	VSS	76	VSS	VSS	VSS	VSS	VSS
35	PB1A	PB1A	PB1A	PB1A	I/O-A16	77	PT10C	PT12A	PT13D	PT15D	I/O-RDY/RCLK
36	PB1D	PB2A	PB3A	PB3B	I/O-A17	78	PT9D	PT11A	PT12C	PT13D	I/O-D7
37	PB2A	PB3A	PB3D	PB4D	I/O	79	PT9C	PT10D	PT11D	PT13A	I/O
38	PB2D	PB3D	PB4D	PB5D	I/O	80	PT9A	PT10A	PT11B	PT12B	I/O-D6
39	PB3A	PB4A	PB5A	PB6A	I/O	81	PT8A	PT9A	PT10A	PT11A	I/O-D5
40	PB4A	PB5A	PB6A	PB7A	I/O	82	PT7D	PT8D	PT9D	PT10D	I/O
41	PB4D	PB5D	PB6D	PB7D	I/O	83	PT7A	PT8A	PT9A	PT10A	I/O-D4
42	PB5A	PB6A	PB7A	PB8A	I/O	84	PT6A	PT7A	PT8A	PT9A	I/O-D3

2

Pin Information (continued)

Table 17. ATT2C04 and ATT2C06 100-Pin TQFP Pinout

Pin	2C04 Pad	2C06 Pad	Function	Pin	2C04 Pad	2C06 Pad	Function
1	VDD	VDD	VDD	43	PB8C	PB9C	I/O
2	VSS	VSS	VSS	44	PB8D	PB9D	I/O
3	PL1C	PL1A	I/O-A0	45	PB9A	PB10A	I/O-LDC
4	PL1A	PL2A	I/O-A1	46	PB9D	PB10D	I/O
5	PL2D	PL3D	I/O-A2	47	PB10A	PB11A	I/O-INIT
6	PL2A	PL3A	I/O-A3	48	PB10D	PB12A	I/O
7	PL3D	PL4D	I/O	49	DONE	DONE	DONE
8	PL3A	PL4A	I/O-A4	50	VDD	VDD	VDD
9	PL4D	PL5D	I/O-A5	51	RESET	RESET	RESET
10	PL4A	PL5A	I/O-A6	52	PRGM	PRGM	PRGM
11	PL5D	PL6D	I/O	53	PR10A	PR12A	I/O-M0
12	PL5A	PL6A	I/O-A7	54	PR10D	PR11A	I/O
13	VDD	VDD	VDD	55	PR9A	PR10A	I/O-M1
14	PL6A	PL7A	I/O-A8	56	PR9D	PR10D	I/O
15	VSS	VSS	VSS	57	PR8A	PR9A	I/O-M2
16	PL7D	PL8D	I/O-A9	58	PR8D	PR9D	I/O
17	PL7A	PL8A	I/O-A10	59	PR7A	PR8A	I/O-M3
18	PL8A	PL9A	I/O-A11	60	PR7D	PR8D	I/O
19	PL9D	PL10D	I/O-A12	61	VSS	VSS	VSS
20	PL9C	PL10C	I/O	62	PR6A	PR7A	I/O
21	PL9A	PL10A	I/O-A13	63	VDD	VDD	VDD
22	PL10D	PL11A	I/O-A14	64	PR5A	PR6A	I/O
23	PL10A	PL12A	I/O-A15	65	VSS	VSS	VSS
24	VSS	VSS	VSS	66	PR4A	PR5A	I/O
25	CCLK	CCLK	CCLK	67	PR4D	PR5D	I/O
26	VDD	VDD	VDD	68	PR3A	PR4A	I/O-CS1
27	VSS	VSS	VSS	69	PR3D	PR4D	I/O
28	PB1A	PB1A	I/O-A16	70	PR2A	PR3A	I/O-CS0
29	PB1C	PB1D	I/O	71	PR2D	PR3D	I/O
30	PB1D	PB2A	I/O-A17	72	PR1A	PR2A	I/O-RD
31	PB2A	PB3A	I/O	73	PR1C	PR2D	I/O
32	PB2D	PB3D	I/O	74	PR1D	PR1A	I/O-WF
33	PB3A	PB4A	I/O	75	RD_CFGN	RD_CFGN	RD_CFGN
34	PB4A	PB5A	I/O	76	VDD	VDD	VDD
35	PB4D	PB5D	I/O	77	VSS	VSS	VSS
36	PB5A	PB6A	I/O	78	PT10C	PT12A	I/O-RDY/RCLK
37	VSS	VSS	VSS	79	PT9D	PT11A	I/O-D7
38	PB6A	PB7A	I/O	80	PT9C	PT10D	I/O
39	VSS	VSS	VSS	81	PT9A	PT10A	I/O-D6
40	PB7A	PB8A	I/O	82	PT8D	PT9D	I/O
41	PB7D	PB8D	I/O	83	PT8A	PT9A	I/O-D5
42	PB8A	PB9A	I/O-HDC	84	PT7D	PT8D	I/O

2

Pin Information (continued)**Table 17. ATT2C04 and ATT2C06 100-Pin TQFP Pinout** (continued)

Pin	2C04 Pad	2C06 Pad	Function	Pin	2C04 Pad	2C06 Pad	Function
85	PT7A	PT8A	I/O-D4	93	PT3D	PT4D	I/O
86	PT6D	PT7D	I/O	94	PT3A	PT4A	I/O-DOUT
87	PT6A	PT7A	I/O-D3	95	PT2D	PT3D	I/O
88	Vss	Vss	Vss	96	PT2A	PT3A	I/O-TDI
89	PT5A	PT6A	I/O-D2	97	PT1D	PT2A	I/O-TMS
90	Vss	Vss	Vss	98	PT1C	PT1D	I/O
91	PT4D	PT5D	I/O-D1	99	PT1A	PT1A	I/O-TCK
92	PT4A	PT5A	I/O-D0/DIN	100	RD_DATA/TDO	RD_DATA/TDO	RD_DATA/TDO

Pin Information (continued)

Table 18. ATT2C04 and ATT2C06 144-Pin TQFP Pinout

Pin	2C04 Pad	2C06 Pad	Function	Pin	2C04 Pad	2C06 Pad	Function
1	VDD	VDD	VDD	43	PB2B	PB3B	I/O
2	VSS	VSS	VSS	44	PB2D	PB3D	I/O
3	PL1C	PL1A	I/O-A0	45	VDD	VDD	VDD
4	PL1B	PL2D	I/O	46	PB3A	PB4A	I/O
5	PL1A	PL2A	I/O-A1	47	PB3D	PB4D	I/O
6	PL2D	PL3D	I/O-A2	48	PB4A	PB5A	I/O
7	PL2A	PL3A	I/O-A3	49	PB4C	PB5C	I/O
8	PL3D	PL4D	I/O	50	PB4D	PB5D	I/O
9	PL3C	PL4C	I/O	51	PB5A	PB6A	I/O
10	PL3A	PL4A	I/O-A4	52	PB5C	PB6C	I/O
11	PL4D	PL5D	I/O-A5	53	PB5D	PB6D	I/O
12	PB4C	PB5C	I/O	54	VSS	VSS	VSS
13	PL4A	PL5A	I/O-A6	55	PB6A	PB7A	I/O
14	VSS	VSS	VSS	56	PB6C	PB7C	I/O
15	PL5D	PL6D	I/O	57	PB6D	PB7D	I/O
16	PL5C	PL6C	I/O	58	PB7A	PB8A	I/O
17	PL5A	PL6A	I/O-A7	59	PB7D	PB8D	I/O
18	VDD	VDD	VDD	60	PB8A	PB9A	I/O-HDC
19	PL6D	PL7D	I/O	61	PB8C	PB9C	I/O
20	PL6C	PL7C	I/O	62	PB8D	PB9D	I/O
21	PL6A	PL7A	I/O-A8	63	VDD	VDD	VDD
22	VSS	VSS	VSS	64	PB9A	PB10A	I/O-LDC
23	PL7D	PL8D	I/O-A9	65	PB9C	PB10C	I/O
24	PL7A	PL8A	I/O-A10	66	PB9D	PB10D	I/O
25	PL8D	PL9D	I/O	67	PB10A	PB11A	I/O-INIT
26	PL8C	PL9C	I/O	68	PB10C	PB11D	I/O
27	PL8A	PL9A	I/O-A11	69	PB10D	PB12A	I/O
28	PL9D	PL10D	I/O-A12	70	VSS	VSS	VSS
29	PB9C	PB10C	I/O	71	DONE	DONE	DONE
30	PL9A	PL10A	I/O-A13	72	VDD	VDD	VDD
31	PL10D	PL11A	I/O-A14	73	VSS	VSS	VSS
32	PL10C	PL12D	I/O	74	RESET	RESET	RESET
33	PL10B	PL12B	I/O	75	PRGM	PRGM	PRGM
34	PL10A	PL12A	I/O-A15	76	PR10A	PR12A	I/O-M0
35	VSS	VSS	VSS	77	PR10B	PR12D	I/O
36	CCLK	CCLK	CCLK	78	PR10D	PR11A	I/O
37	VDD	VDD	VDD	79	PR9A	PR10A	I/O-M1
38	VSS	VSS	VSS	80	PR9C	PR10C	I/O
39	PB1A	PB1A	I/O-A16	81	PR9D	PR10D	I/O
40	PB1C	PB1D	I/O	82	PR8A	PR9A	I/O-M2
41	PB1D	PB2A	I/O-A17	83	PR8B	PR9B	I/O
42	PB2A	PB3A	I/O	84	PR8D	PR9D	I/O

2

Pin Information (continued)

Table 18. ATT2C04 and ATT2C06 144-Pin TQFP Pinout (continued)

Pin	2C04 Pad	2C06 Pad	Function	Pin	2C04 Pad	2C06 Pad	Function
85	PR7A	PR8A	I/O-M3	115	PT9C	PT10D	I/O
86	PR7D	PR8D	I/O	116	PT9B	PT10C	I/O
87	Vss	Vss	Vss	117	PT9A	PT10A	I/O-D6
88	PR6A	PR7A	I/O	118	Vdd	Vdd	Vdd
89	PR6C	PR7C	I/O	119	PT8D	PT9D	I/O
90	PR6D	PR7D	I/O	120	PT8A	PT9A	I/O-D5
91	Vdd	Vdd	Vdd	121	PT7D	PT8D	I/O
92	PR5A	PR6A	I/O	122	PT7B	PT8B	I/O
93	PR5C	PR6C	I/O	123	PT7A	PT8A	I/O-D4
94	PR5D	PR6D	I/O	124	PT6D	PT7D	I/O
95	Vss	Vss	Vss	125	PT6C	PT7C	I/O
96	PR4A	PR5A	I/O	126	PT6A	PT7A	I/O-D3
97	PR4C	PR5C	I/O	127	Vss	Vss	Vss
98	PR4D	PR5D	I/O	128	PT5D	PT6D	I/O
99	PR3A	PR4A	I/O-CS1	129	PT5C	PT6C	I/O
100	PR3D	PR4D	I/O	130	PT5A	PT6A	I/O-D2
101	PR2A	PR3A	I/O-CS0	131	PT4D	PT5D	I/O-D1
102	PR2D	PR3D	I/O	132	PT4C	PT5C	I/O
103	PR1A	PR2A	I/O-RD	133	PT4A	PT5A	I/O-D0/DIN
104	PR1B	PR2B	I/O	134	PT3D	PT4D	I/O
105	PR1C	PR2D	I/O	135	PT3A	PT4A	I/O-DOUT
106	PR1D	PR1A	I/O-WR	136	Vdd	Vdd	Vdd
107	Vss	Vss	Vss	137	PT2D	PT3D	I/O
108	RD_CFGN	RD_CFGN	RD_CFGN	138	PT2C	PT3C	I/O
109	Vdd	Vdd	Vdd	139	PT2A	PT3A	I/O-TDI
110	Vss	Vss	Vss	140	PT1D	PT2A	I/O-TMS
111	PT10D	PT10D	I/O	141	PT1C	PT1D	I/O
112	PT10C	PT12A	I/O-RDY/RCLK	142	PT1A	PT1A	I/O-TCK
113	PT10B	PT11D	I/O	143	Vss	Vss	Vss
114	PT9D	PT11A	I/O-D7	144	RD_DATA/ TDO	RD_DATA/ TDO	RD_DATA/TDO

2

Pin Information (continued)

Table 19. ATT2C04, ATT2C06, ATT2C08, and ATT2C10 160-Pin QFP Pinout

Pin	2C04 Pad	2C06 Pad	2C08 Pad	2C10 Pad	Function
1	VDD	VDD	VDD	VDD	VDD
2	VSS	VSS	VSS	VSS	VSS
3	PL1D	PL1D	PL1D	PL1D	I/O
4	PL1C	PL1A	PL2D	PL2D	I/O-A0
5	PL1B	PL2D	PL3D	PL3D	I/O
6	PL1A	PL2A	PL3A	PL3A	I/O-A1
7	PL2D	PL3D	PL4D	PL4A	I/O-A2
8	PL2C	PL3C	PL4C	PL5C	I/O
9	PL2A	PL3A	PL4A	PL5A	I/O-A3
10	PL3D	PL4D	PL5D	PL6D	I/O
11	PL3C	PL4C	PL5C	PL6C	I/O
12	PL3A	PL4A	PL5A	PL6A	I/O-A4
13	PL4D	PL5D	PL6D	PL7D	I/O-A5
14	PL4C	PL5C	PL6C	PL7C	I/O
15	PL4A	PL5A	PL6A	PL7A	I/O-A6
16	VSS	VSS	VSS	VSS	VSS
17	PL5D	PL6D	PL7D	PL8D	I/O
18	PL5C	PL6C	PL7C	PL8C	I/O
19	PL5A	PL6A	PL7A	PL8A	I/O-A7
20	VDD	VDD	VDD	VDD	VDD
21	PL6D	PL7D	PL8D	PL9D	I/O
22	PL6C	PL7C	PL8C	PL9C	I/O
23	PL6A	PL7A	PL8A	PL9A	I/O-A8
24	VSS	VSS	VSS	VSS	VSS
25	PL7D	PL8D	PL9D	PL10D	I/O-A9
26	PL7B	PL8B	PL9B	PL10B	I/O
27	PL7A	PL8A	PL9A	PL10A	I/O-A10
28	PL8D	PL9D	PL10D	PL11D	I/O
29	PL8C	PL9C	PL10C	PL11C	I/O
30	PL8A	PL9A	PL10A	PL11A	I/O-A11
31	PL9D	PL10D	PL11D	PL12D	I/O-A12
32	PL9C	PL10C	PL11C	PL12C	I/O
33	PL9B	PL10B	PL11B	PL12B	I/O
34	PL9A	PL10A	PL11A	PL13D	I/O-A13
35	PL10D	PL11A	PL12A	PL14C	I/O-A14
36	PL10C	PL12D	PL13D	PL15D	I/O
37	PL10B	PL12B	PL14D	PL16D	I/O
38	PL10A	PL12A	PL14A	PL16A	I/O-A15
39	CCLK	CCLK	CCLK	CCLK	CCLK
40	VSS	VSS	VSS	VSS	VSS
41	VDD	VDD	VDD	VDD	VDD
42	VSS	VSS	VSS	VSS	VSS
43	PB1A	PB1A	PB1A	PB1A	I/O-A16

Pin Information (continued)

Table 19. ATT2C04, ATT2C06, ATT2C08, and ATT2C10 160-Pin QFP Pinout (continued)

Pin	2C04 Pad	2C06 Pad	2C08 Pad	2C10 Pad	Function
44	PB1B	PB1C	PB2A	PB2A	I/O
45	PB1C	PB1D	PB2D	PB2D	I/O
46	PB1D	PB2A	PB3A	PB3B	I/O-A17
47	PB2A	PB3A	PB3D	PB4D	I/O
48	PB2B	PB3B	PB4A	PB5A	I/O
49	PB2C	PB3C	PB4C	PB5C	I/O
50	PB2D	PB3D	PB4D	PB5D	I/O
51	VDD	VDD	VDD	VDD	VDD
52	PB3A	PB4A	PB5A	PB6A	I/O
53	PB3D	PB4D	PB5D	PB6D	I/O
54	PB4A	PB5A	PB6A	PB7A	I/O
55	PB4C	PB5C	PB6C	PB7C	I/O
56	PB4D	PB5D	PB6D	PB7D	I/O
57	PB5A	PB6A	PB7A	PB8A	I/O
58	PB5C	PB6C	PB7C	PB8C	I/O
59	PB5D	PB6D	PB7D	PB8D	I/O
60	VSS	VSS	VSS	VSS	VSS
61	PB6A	PB7A	PB8A	PB9A	I/O
62	PB6C	PB7C	PB8C	PB9C	I/O
63	PB6D	PB7D	PB8D	PB9D	I/O
64	PB7A	PB8A	PB9A	PB10A	I/O
65	PB7D	PB8D	PB9D	PB10D	I/O
66	PB8A	PB9A	PB10A	PB11A	I/O-HDC
67	PB8C	PB9C	PB10C	PB11C	I/O
68	PB8D	PB9D	PB10D	PB11D	I/O
69	VDD	VDD	VDD	VDD	VDD
70	PB9A	PB10A	PB11A	PB12A	I/O-LDC
71	PB9B	PB10B	PB11D	PB13A	I/O
72	PB9C	PB10C	PB12A	PB13B	I/O
73	PB9D	PB10D	PB12B	PB13C	I/O
74	PB10A	PB11A	PB12C	PB13D	I/O-INIT
75	PB10B	PB11C	PB12D	PB14A	I/O
76	PB10C	PB11D	PB13D	PB15D	I/O
77	PB10D	PB12A	PB14D	PB16D	I/O
78	VSS	VSS	VSS	VSS	VSS
79	DONE	DONE	DONE	DONE	DONE
80	VDD	VDD	VDD	VDD	VDD
81	VSS	VSS	VSS	VSS	VSS
82	RESET	RESET	RESET	RESET	RESET
83	PRGM	PRGM	PRGM	PRGM	PRGM
84	PR10A	PR12A	PR14A	PR16A	I/O-MO
85	PR10B	PR12D	PR13A	PR15A	I/O

Pin Information (continued)

Table 19. ATT2C04, ATT2C06, ATT2C08, and ATT2C10 160-Pin QFP Pinout (continued)

Pin	2C04 Pad	2C06 Pad	2C08 Pad	2C10 Pad	Function
86	PR10C	PR11A	PR13D	PR15D	I/O
87	PR10D	PR11B	PR12A	PR14A	I/O
88	PR9A	PR10A	PR11A	PR13B	I/O-M1
89	PR9B	PR10B	PR11B	PR13C	I/O
90	PR9C	PR10C	PR11C	PR12A	I/O
91	PR9D	PR10D	PR11D	PR12B	I/O
92	PR8A	PR9A	PR10A	PR11A	I/O-M2
93	PR8B	PR9B	PR10B	PR11B	I/O
94	PR8D	PR9D	PR10D	PR11D	I/O
95	PR7A	PR8A	PR9A	PR10A	I/O-M3
96	PR7D	PR8D	PR9D	PR10D	I/O
97	Vss	Vss	Vss	Vss	Vss
98	PR6A	PR7A	PR8A	PR9A	I/O
99	PR6C	PR7C	PR8C	PR9C	I/O
100	PR6D	PR7D	PR8D	PR9D	I/O
101	Vdd	Vdd	Vdd	Vdd	Vdd
102	PR5A	PR6A	PR7A	PR8A	I/O
103	PR5C	PR6C	PR7C	PR8C	I/O
104	PR5D	PR6D	PR7D	PR8D	I/O
105	Vss	Vss	Vss	Vss	Vss
106	PR4A	PR5A	PR6A	PR7A	I/O
107	PR4C	PR5C	PR6C	PR7C	I/O
108	PR4D	PR5D	PR6D	PR7D	I/O
109	PR3A	PR4A	PR5A	PR6A	I/O-CS1
110	PR3B	PR4B	PR5B	PR6B	I/O
111	PR3D	PR4D	PR5D	PR6D	I/O
112	PR2A	PR3A	PR4A	PR5A	I/O-CS0
113	PR2C	PR3C	PR4B	PR4B	I/O
114	PR2D	PR3D	PR4D	PR4D	I/O
115	PR1A	PR2A	PR3A	PR3A	I/O-RD
116	PR1B	PR2C	PR3C	PR3C	I/O
117	PR1C	PR2D	PR3D	PR3D	I/O
118	PR1D	PR1A	PR2A	PR2A	I/O-WR
119	Vss	Vss	Vss	Vss	Vss
120	RD_CFGN	RD_CFGN	RD_CFGN	RD_CFGN	RD_CFGN
121	Vdd	Vdd	Vdd	Vdd	Vdd
122	Vss	Vss	Vss	Vss	Vss
123	PT10D	PT12D	PT14D	PT16D	I/O
124	PT10C	PT12A	PT13D	PT15D	I/O-RDY/RCLK
125	PT10B	PT11D	PT13A	PT15A	I/O
126	PT10A	PT11C	PT12D	PT14D	I/O
127	PT9D	PT11A	PT12C	PT13D	I/O-D7

2

Pin Information (continued)

Table 19. ATT2C04, ATT2C06, ATT2C08, and ATT2C10 160-Pin QFP Pinout (continued)

Pin	2C04 Pad	2C06 Pad	2C08 Pad	2C10 Pad	Function
128	PT9C	PT10D	PT12A	PT13B	I/O
129	PT9B	PT10C	PT11D	PT13A	I/O
130	PT9A	PT10A	PT11B	PT12B	I/O-D6
131	VDD	VDD	VDD	VDD	VDD
132	PT8D	PT9D	PT10D	PT11D	I/O
133	PT8A	PT9A	PT10A	PT11A	I/O-D5
134	PT7D	PT8D	PT9D	PT10D	I/O
135	PT7B	PT8B	PT9B	PT10B	I/O
136	PT7A	PT8A	PT9A	PT10A	I/O-D4
137	PT6D	PT7D	PT8D	PT9D	I/O
138	PT6C	PT7C	PT8C	PT9C	I/O
139	PT6A	PT7A	PT8A	PT9A	I/O-D3
140	VSS	VSS	VSS	VSS	VSS
141	PT5D	PT6D	PT7D	PT8D	I/O
142	PT5C	PT6C	PT7C	PT8C	I/O
143	PT5A	PT6A	PT7A	PT8A	I/O-D2
144	PT4D	PT5D	PT6D	PT7D	I/O-D1
145	PT4C	PT5C	PT6C	PT7C	I/O
146	PT4A	PT5A	PT6A	PT7A	I/O-D0/DIN
147	PT3D	PT4D	PT5D	PT6D	I/O
148	PT3C	PT4C	PT5C	PT6C	I/O
149	PT3A	PT4A	PT5A	PT6A	I/O-DOUT
150	VDD	VDD	VDD	VDD	VDD
151	PT2D	PT3D	PT4D	PT5D	I/O
152	PT2C	PT3C	PT4C	PT5A	I/O
153	PT2B	PT3B	PT4B	PT4D	I/O
154	PT2A	PT3A	PT4A	PT4A	I/O-TDI
155	PT1D	PT2A	PT3A	PT3A	I/O-TMS
156	PT1C	PT1D	PT2A	PT2A	I/O
157	PT1B	PT1C	PT1D	PT1D	I/O
158	PT1A	PT1A	PT1A	PT1A	I/O-TCK
159	VSS	VSS	VSS	VSS	VSS
160	RD_DATA/TDO	RD_DATA/TDO	RD_DATA/TDO	RD_DATA/TDO	RD_DATA/TDO

Pin Information (continued)

Table 20. ATT2C04, ATT2C06, ATT2C08, ATT2C10, ATT2C12, ATT2C15, ATT2C26, and ATT2C40 208-Pin SQFP/SQFP-PQ2 Pinout

Pin	2C04 Pad	2C06 Pad	2C08 Pad	2C10 Pad	2C12 Pad	2C15 Pad	2C26 Pad	2C40 Pad	Function
1	VSS	VSS	VSS	VSS	VSS	VSS	VSS	VSS	VSS
2	VSS	VSS	VSS	VSS	VSS	VSS	VSS	VSS	VSS
3	PL1D	PL1D	PL1D	PL1D	PL1D	PL1D	PL1D	PL1D	I/O
4	PL1C	PL1A	PL2D	PL2D	PL2D	PL2D	PL2D	PL3D	I/O-A0
5	PL1B	PL2D	PL3D	PL3D	PL3D	PL4D	PL4D	PL5D	I/O
6	See Note	PL2C	PL3C	PL3C	PL3A	PL4A	PL4A	PL6D	I/O
7	PL1A	PL2A	PL3A	PL3A	PL4A	PL5A	PL5A	PL8D	I/O-A1
8	PL2D	PL3D	PL4D	PL4A	PL5A	PL6A	PL6A	PL9A	I/O-A2
9	PL2C	PL3C	PL4C	PL5C	PL6D	PL7D	PL7D	PL10D	I/O
10	PL2B	PL3B	PL4B	PL5B	PL6B	PL7B	PL7B	PL10B	I/O
11	PL2A	PL3A	PL4A	PL5A	PL6A	PL7A	PL7A	PL10A	I/O-A3
12	VDD	VDD	VDD	VDD	VDD	VDD	VDD	VDD	VDD
13	PL3D	PL4D	PL5D	PL6D	PL7D	PL8D	PL8D	PL11D	I/O
14	PL3C	PL4C	PL5C	PL6C	PL7C	PL8C	PL8A	PL11A	I/O
15	PL3B	PL4B	PL5B	PL6B	PL7B	PL8B	PL9D	PL12D	I/O
16	PL3A	PL4A	PL5A	PL6A	PL7A	PL8A	PL9A	PL12A	I/O-A4
17	PL4D	PL5D	PL6D	PL7D	PL8D	PL9D	PL10D	PL13D	I/O-A5
18	PL4C	PL5C	PL6C	PL7C	PL8C	PL9C	PL10A	PL13A	I/O
19	PL4B	PL5B	PL6B	PL7B	PL8B	PL9B	PL11D	PL14D	I/O
20	PL4A	PL5A	PL6A	PL7A	PL8A	PL9A	PL11A	PL14A	I/O-A6
21	VSS	VSS	VSS	VSS	VSS	VSS	VSS	VSS	VSS
22	PL5D	PL6D	PL7D	PL8D	PL9D	PL10D	PL12D	PL15D	I/O
23	PL5C	PL6C	PL7C	PL8C	PL9C	PL10C	PL12C	PL15C	I/O
24	PL5B	PL6B	PL7B	PL8B	PL9B	PL10B	PL12B	PL15B	I/O
25	PL5A	PL6A	PL7A	PL8A	PL9A	PL10A	PL12A	PL15A	I/O-A7
26	VDD	VDD	VDD	VDD	VDD	VDD	VDD	VDD	VDD
27	PL6D	PL7D	PL8D	PL9D	PL10D	PL11D	PL13D	PL16D	I/O
28	PL6C	PL7C	PL8C	PL9C	PL10C	PL11C	PL13C	PL16C	I/O
29	PL6B	PL7B	PL8B	PL9B	PL10B	PL11B	PL13B	PL16B	I/O
30	PL6A	PL7A	PL8A	PL9A	PL10A	PL11A	PL13A	PL16A	I/O-A8
31	VSS	VSS	VSS	VSS	VSS	VSS	VSS	VSS	VSS
32	PL7D	PL8D	PL9D	PL10D	PL11D	PL12D	PL14D	PL17D	I/O-A9
33	PL7C	PL8C	PL9C	PL10C	PL11C	PL12C	PL14A	PL17A	I/O
34	PL7B	PL8B	PL9B	PL10B	PL11B	PL12B	PL15D	PL18D	I/O
35	PL7A	PL8A	PL9A	PL10A	PL11A	PL12A	PL15A	PL18A	I/O-A10
36	PL8D	PL9D	PL10D	PL11D	PL12D	PL13D	PL16D	PL19D	I/O
37	PL8C	PL9C	PL10C	PL11C	PL12C	PL13C	PL16A	PL19A	I/O
38	PL8B	PL9B	PL10B	PL11B	PL12B	PL13B	PL17D	PL20D	I/O

Note: The ATT2C04 does not have bond pads connected to 208-pin SQFP package pin numbers 6, 45, 47, 56, 60, 102, 153, 154, 166, 201, and 203.

Pin Information (continued)

Table 20. ATT2C04, ATT2C06, ATT2C08, ATT2C10, ATT2C12, ATT2C15, ATT2C26, and ATT2C40 208-Pin SQFP/SQFP-PQ2 Pinout (continued)

Pin	2C04 Pad	2C06 Pad	2C08 Pad	2C10 Pad	2C12 Pad	2C15 Pad	2C26 Pad	2C40 Pad	Function
39	PL8A	PL9A	PL10A	PL11A	PL12A	PL13A	PL17A	PL20A	I/O-A11
40	VDD	VDD	VDD	VDD	VDD	VDD	VDD	VDD	VDD
41	PL9D	PL10D	PL11D	PL12D	PL13D	PL14D	PL18D	PL21D	I/O-A12
42	PL9C	PL10C	PL11C	PL12C	PL13B	PL14B	PL18B	PL21B	I/O
43	PL9B	PL10B	PL11B	PL12B	PL14D	PL15D	PL19D	PL22D	I/O
44	PL9A	PL10A	PL11A	PL13D	PL14B	PL15B	PL19B	PL22B	I/O-A13
45	See Note	PL11D	PL12D	PL13B	PL15D	PL16D	PL20D	PL23D	I/O
46	PL10D	PL11A	PL12A	PL14C	PL16D	PL17D	PL21D	PL25A	I/O-A14
47	See Note	PL12D	PL13D	PL15D	PL17D	PL18D	PL22D	PL27D	I/O
48	PL10C	PL12C	PL13A	PL15A	PL17A	PL19D	PL23D	PL28D	I/O
49	PL10B	PL12B	PL14D	PL16D	PL18C	PL19A	PL23A	PL28A	I/O
50	PL10A	PL12A	PL14A	PL16A	PL18A	PL20A	PL24A	PL30A	I/O-A15
51	VSS	VSS	VSS	VSS	VSS	VSS	VSS	VSS	VSS
52	CCLK	CCLK	CCLK	CCLK	CCLK	CCLK	CCLK	CCLK	CCLK
53	VSS	VSS	VSS	VSS	VSS	VSS	VSS	VSS	VSS
54	VSS	VSS	VSS	VSS	VSS	VSS	VSS	VSS	VSS
55	PB1A	PB1A	PB1A	PB1A	PB1A	PB1A	PB1A	PB1A	I/O-A16
56	See Note	PB1B	PB1D	PB1D	PB1D	PB2A	PB2A	PB3A	I/O
57	PB1B	PB1C	PB2A	PB2A	PB2A	PB2D	PB2D	PB3D	I/O
58	PB1C	PB1D	PB2D	PB2D	PB2D	PB3D	PB3D	PB4D	I/O
59	PB1D	PB2A	PB3A	PB3B	PB3D	PB4D	PB4D	PB5D	I/O-A17
60	See Note	PB2D	PB3D	PB4D	PB4D	PB5D	PB5D	PB6D	I/O
61	PB2A	PB3A	PB4A	PB5A	PB5B	PB6B	PB6B	PB7D	I/O
62	PB2B	PB3B	PB4B	PB5B	PB5D	PB6D	PB6D	PB8D	I/O
63	PB2C	PB3C	PB4C	PB5C	PB6B	PB7B	PB7B	PB9D	I/O
64	PB2D	PB3D	PB4D	PB5D	PB6D	PB7D	PB7D	PB10D	I/O
65	VDD	VDD	VDD	VDD	VDD	VDD	VDD	VDD	VDD
66	PB3A	PB4A	PB5A	PB6A	PB7A	PB8A	PB8A	PB11A	I/O
67	PB3B	PB4B	PB5B	PB6B	PB7B	PB8B	PB8D	PB11D	I/O
68	PB3C	PB4C	PB5C	PB6C	PB7C	PB8C	PB9A	PB12A	I/O
69	PB3D	PB4D	PB5D	PB6D	PB7D	PB8D	PB9D	PB12D	I/O
70	PB4A	PB5A	PB6A	PB7A	PB8A	PB9A	PB10A	PB13A	I/O
71	PB4B	PB5B	PB6B	PB7B	PB8B	PB9B	PB10D	PB13D	I/O
72	PB4C	PB5C	PB6C	PB7C	PB8C	PB9C	PB11A	PB14A	I/O
73	PB4D	PB5D	PB6D	PB7D	PB8D	PB9D	PB11D	PB14D	I/O
74	VSS	VSS	VSS	VSS	VSS	VSS	VSS	VSS	VSS

Note: The ATT2C04 does not have bond pads connected to 208-pin SQFP package pin numbers 6, 45, 47, 56, 60, 102, 153, 154, 166, 201, and 203.

2

Pin Information (continued)

Table 20. ATT2C04, ATT2C06, ATT2C08, ATT2C10, ATT2C12, ATT2C15, ATT2C26, and ATT2C40 208-Pin SQFP/SQFP-PQ2 Pinout (continued)

Pin	2C04 Pad	2C06 Pad	2C08 Pad	2C10 Pad	2C12 Pad	2C15 Pad	2C26 Pad	2C40 Pad	Function
75	PB5A	PB6A	PB7A	PB8A	PB9A	PB10A	PB12A	PB15A	I/O
76	PB5B	PB6B	PB7B	PB8B	PB9B	PB10B	PB12B	PB15B	I/O
77	PB5C	PB6C	PB7C	PB8C	PB9C	PB10C	PB12C	PB15C	I/O
78	PB5D	PB6D	PB7D	PB8D	PB9D	PB10D	PB12D	PB15D	I/O
79	VSS	VSS	VSS	VSS	VSS	VSS	VSS	VSS	VSS
80	PB6A	PB7A	PB8A	PB9A	PB10A	PB11A	PB13A	PB16A	I/O
81	PB6B	PB7B	PB8B	PB9B	PB10B	PB11B	PB13B	PB16B	I/O
82	PB6C	PB7C	PB8C	PB9C	PB10C	PB11C	PB13C	PB16C	I/O
83	PB6D	PB7D	PB8D	PB9D	PB10D	PB11D	PB13D	PB16D	I/O
84	VSS	VSS	VSS	VSS	VSS	VSS	VSS	VSS	VSS
85	PB7A	PB8A	PB9A	PB10A	PB11A	PB12A	PB14A	PB17A	I/O
86	PB7B	PB8B	PB9B	PB10B	PB11B	PB12B	PB14D	PB17D	I/O
87	PB7C	PB8C	PB9C	PB10C	PB11C	PB12C	PB15A	PB18A	I/O
88	PB7D	PB8D	PB9D	PB10D	PB11D	PB12D	PB15D	PB18D	I/O
89	PB8A	PB9A	PB10A	PB11A	PB12A	PB13A	PB16A	PB19A	I/O-HDC
90	PB8B	PB9B	PB10B	PB11B	PB12B	PB13B	PB16D	PB19D	I/O
91	PB8C	PB9C	PB10C	PB11C	PB12C	PB13C	PB17A	PB20A	I/O
92	PB8D	PB9D	PB10D	PB11D	PB12D	PB13D	PB17D	PB20D	I/O
93	VDD	VDD	VDD	VDD	VDD	VDD	VDD	VDD	VDD
94	PB9A	PB10A	PB11A	PB12A	PB13A	PB14A	PB18A	PB21A	I/O-LDC
95	PB9B	PB10B	PB11D	PB13A	PB13D	PB14D	PB18D	PB22D	I/O
96	PB9C	PB10C	PB12A	PB13B	PB14A	PB15A	PB19A	PB23A	I/O
97	PB9D	PB10D	PB12B	PB13C	PB14D	PB15D	PB19D	PB24D	I/O
98	PB10A	PB11A	PB12C	PB13D	PB15A	PB16A	PB20A	PB25A	I/O-INIT
99	PB10B	PB11C	PB12D	PB14A	PB16A	PB17A	PB21A	PB26A	I/O
100	PB10C	PB11D	PB13A	PB15A	PB17A	PB18A	PB22A	PB1A	I/O
101	PB10D	PB12A	PB13D	PB15D	PB18A	PB19D	PB23D	PB28D	I/O
102	See Note	PB12D	PB14D	PB16D	PB18D	PB20D	PB24D	PB30D	I/O
103	VSS	VSS	VSS	VSS	VSS	VSS	VSS	VSS	VSS
104	DONE	DONE	DONE	DONE	DONE	DONE	DONE	DONE	DONE
105	VSS	VSS	VSS	VSS	VSS	VSS	VSS	VSS	VSS
106	RESET	RESET	RESET	RESET	RESET	RESET	RESET	RESET	RESET
107	PRGM	PRGM	PRGM	PRGM	PRGM	PRGM	PRGM	PRGM	PRGM
108	PR10A	PR12A	PR14A	PR16A	PR18A	PR20A	PR24A	PR30A	I/O-M0
109	PR10B	PR12D	PR13A	PR15A	PR18D	PR19A	PR23A	PR28A	I/O
110	PR10C	PR11A	PR13D	PR15D	PR17B	PR18A	PR22A	PR27A	I/O

Note: The ATT2C04 does not have bond pads connected to 208-pin SQFP package pin numbers 6, 45, 47, 56, 60, 102, 153, 154, 166, 201, and 203.

Pin Information (continued)

Table 20. ATT2C04, ATT2C06, ATT2C08, ATT2C10, ATT2C12, ATT2C15, ATT2C26, and ATT2C40 208-Pin SQFP/SQFP-PQ2 Pinout (continued)

Pin	2C04 Pad	2C06 Pad	2C08 Pad	2C10 Pad	2C12 Pad	2C15 Pad	2C26 Pad	2C40 Pad	Function
111	PR10D	PR11B	PR12A	PR14A	PR16A	PR17A	PR21A	PR26A	I/O
112	PR9A	PR10A	PR11A	PR13B	PR15D	PR16D	PR20D	PR23D	I/O-M1
113	PR9B	PR10B	PR11B	PR13C	PR14A	PR15A	PR19A	PR22A	I/O
114	PR9C	PR10C	PR11C	PR12A	PR14D	PR15D	PR19D	PR22D	I/O
115	PR9D	PR10D	PR11D	PR12B	PR13A	PR14A	PR18A	PR21A	I/O
116	VDD	VDD	VDD	VDD	VDD	VDD	VDD	VDD	VDD
117	PR8A	PR9A	PR10A	PR11A	PR12A	PR13A	PR17A	PR20A	I/O-M2
118	PR8B	PR9B	PR10B	PR11B	PR12B	PR13B	PR17D	PR20D	I/O
119	PR8C	PR9C	PR10C	PR11C	PR12C	PR13C	PR16A	PR19A	I/O
120	PR8D	PR9D	PR10D	PR11D	PR12D	PR13D	PR16D	PR19D	I/O
121	PR7A	PR8A	PR9A	PR10A	PR11A	PR12A	PR15A	PR18A	I/O-M3
122	PR7B	PR8B	PR9B	PR10B	PR11B	PR12B	PR15D	PR18D	I/O
123	PR7C	PR8C	PR9C	PR10C	PR11C	PR12C	PR14A	PR17A	I/O
124	PR7D	PR8D	PR9D	PR10D	PR11D	PR12D	PR14D	PR17D	I/O
125	VSS	VSS	VSS	VSS	VSS	VSS	VSS	VSS	VSS
126	PR6A	PR7A	PR8A	PR9A	PR10A	PR11A	PR13A	PR16A	I/O
127	PR6B	PR7B	PR8B	PR9B	PR10B	PR11B	PR13B	PR16B	I/O
128	PR6C	PR7C	PR8C	PR9C	PR10C	PR11C	PR13C	PR16C	I/O
129	PR6D	PR7D	PR8D	PR9D	PR10D	PR11D	PR13D	PR16D	I/O
130	VDD	VDD	VDD	VDD	VDD	VDD	VDD	VDD	VDD
131	PR5A	PR6A	PR7A	PR8A	PR9A	PR10A	PR12A	PR15A	I/O
132	PR5B	PR6B	PR7B	PR8B	PR9B	PR10B	PR12B	PR15B	I/O
133	PR5C	PR6C	PR7C	PR8C	PR9C	PR10C	PR12C	PR15C	I/O
134	PR5D	PR6D	PR7D	PR8D	PR9D	PR10D	PR12D	PR15D	I/O
135	VSS	VSS	VSS	VSS	VSS	VSS	VSS	VSS	VSS
136	PR4A	PR5A	PR6A	PR7A	PR8A	PR9A	PR11A	PR14A	I/O
137	PR4B	PR5B	PR6B	PR7B	PR8B	PR9B	PR11D	PR14D	I/O
138	PR4C	PR5C	PR6C	PR7C	PR8C	PR9C	PR10A	PR13A	I/O
139	PR4D	PR5D	PR6D	PR7D	PR8D	PR9D	PR10D	PR13D	I/O
140	PR3A	PR4A	PR5A	PR6A	PR7A	PR8A	PR9A	PR12A	I/O-CS1
141	PR3B	PR4B	PR5B	PR6B	PR7B	PR8B	PR9D	PR12D	I/O
142	PR3C	PR4C	PR5C	PR6C	PR7C	PR8C	PR8A	PR11A	I/O
143	PR3D	PR4D	PR5D	PR6D	PR7D	PR8D	PR8D	PR11D	I/O
144	VDD	VDD	VDD	VDD	VDD	VDD	VDD	VDD	VDD
145	PR2A	PR3A	PR4A	PR5A	PR6A	PR7A	PR7A	PR10A	I/O-CS0
146	PR2B	PR3B	PR4B	PR4B	PR6B	PR7B	PR7B	PR10B	I/O

Note: The ATT2C04 does not have bond pads connected to 208-pin SQFP package pin numbers 6, 45, 47, 56, 60, 102, 153, 154, 166, 201, and 203.

Pin Information (continued)

Table 20. ATT2C04, ATT2C06, ATT2C08, ATT2C10, ATT2C12, ATT2C15, ATT2C26, and ATT2C40 208-Pin SQFP/SQFP-PQ2 Pinout (continued)

Pin	2C04 Pad	2C06 Pad	2C08 Pad	2C10 Pad	2C12 Pad	2C15 Pad	2C26 Pad	2C40 Pad	Function
147	PR2C	PR3C	PR4C	PR4C	PR5B	PR6B	PR6B	PR9B	I/O
148	PR2D	PR3D	PR4D	PR4D	PR5D	PR6D	PR6D	PR9D	I/O
149	PR1A	PR2A	PR3A	PR3A	PR4A	PR5A	PR5A	PR8A	I/O-RD
150	PR1B	PR2C	PR3C	PR3C	PR4D	PR5D	PR5D	PR6A	I/O
151	PR1C	PR2D	PR3D	PR3D	PR3A	PR4A	PR4A	PR5A	I/O
152	PR1D	PR1A	PR2A	PR2A	PR2A	PR3A	PR3A	PR4A	I/O-WR
153	See Note	PR1C	PR2D	PR2D	PR2C	PR2A	PR2A	PR3A	I/O
154	See Note	PR1D	PR1A	PR1A	PR1A	PR1A	PR1A	PR2A	I/O
155	VSS	VSS	VSS	VSS	VSS	VSS	VSS	VSS	VSS
156	RD_CFGN	RD_CFGN	RD_CFGN	RD_CFGN	RD_CFGN	RD_CFGN	RD_CFGN	RD_CFGN	RD_CFGN
157	VSS	VSS	VSS	VSS	VSS	VSS	VSS	VSS	VSS
158	VSS	VSS	VSS	VSS	VSS	VSS	VSS	VSS	VSS
159	PT10D	PT12D	PT14D	PT16D	PT18D	PT20D	PT24D	PT30D	I/O
160	PT10C	PT12A	PT13D	PT15D	PT17D	PT19A	PT23A	PT28A	I/O-RDY/RCLK
161	PT10B	PT11D	PT13A	PT15A	PT16D	PT17D	PT21D	PT26D	I/O
162	PT10A	PT11C	PT12D	PT14D	PT16A	PT17A	PT21A	PT26A	I/O
163	PT9D	PT11A	PT12C	PT13D	PT15D	PT16D	PT20D	PT25D	I/O-D7
164	PT9C	PT10D	PT12A	PT13B	PT14D	PT15D	PT19D	PT24D	I/O
165	PT9B	PT10C	PT11D	PT13A	PT14A	PT15A	PT19A	PT23D	I/O
166	See Note	PT10B	PT11C	PT12D	PT13D	PT14D	PT18D	PT22D	I/O
167	PT9A	PT10A	PT11B	PT12B	PT13B	PT14B	PT18B	PT21D	I/O-D6
168	VDD	VDD	VDD	VDD	VDD	VDD	VDD	VDD	VDD
169	PT8D	PT9D	PT10D	PT11D	PT12D	PT13D	PT17D	PT20D	I/O
170	PT8C	PT9C	PT10C	PT11C	PT12C	PT13C	PT17A	PT20A	I/O
171	PT8B	PT9B	PT10B	PT11B	PT12B	PT13B	PT16D	PT19D	I/O
172	PT8A	PT9A	PT10A	PT11A	PT12A	PT13A	PT16A	PT19A	I/O-D5
173	PT7D	PT8D	PT9D	PT10D	PT11D	PT12D	PT15D	PT18D	I/O
174	PT7C	PT8C	PT9C	PT10C	PT11C	PT12C	PT15A	PT18A	I/O
175	PT7B	PT8B	PT9B	PT10B	PT11B	PT12B	PT14D	PT17D	I/O
176	PT7A	PT8A	PT9A	PT10A	PT11A	PT12A	PT14A	PT17A	I/O-D4
177	VSS	VSS	VSS	VSS	VSS	VSS	VSS	VSS	VSS
178	PT6D	PT7D	PT8D	PT9D	PT10D	PT11D	PT13D	PT16D	I/O
179	PT6C	PT7C	PT8C	PT9C	PT10C	PT11C	PT13C	PT16C	I/O
180	PT6B	PT7B	PT8B	PT9B	PT10B	PT11B	PT13B	PT16B	I/O
181	PT6A	PT7A	PT8A	PT9A	PT10A	PT11A	PT13A	PT16A	I/O-D3
182	VSS	VSS	VSS	VSS	VSS	VSS	VSS	VSS	VSS

Note: The ATT2C04 does not have bond pads connected to 208-pin SQFP package pin numbers 6, 45, 47, 56, 60, 102, 153, 154, 166, 201, and 203.

Pin Information (continued)

Table 20. ATT2C04, ATT2C06, ATT2C08, ATT2C10, ATT2C12, ATT2C15, ATT2C26, and ATT2C40 208-Pin SQFP/SQFP-PQ2 Pinout (continued)

Pin	2C04 Pad	2C06 Pad	2C08 Pad	2C10 Pad	2C12 Pad	2C15 Pad	2C26 Pad	2C40 Pad	Function
183	PT5D	PT6D	PT7D	PT8D	PT9D	PT10D	PT12D	PT15D	I/O
184	PT5C	PT6C	PT7C	PT8C	PT9C	PT10C	PT12C	PT15C	I/O
185	PT5B	PT6B	PT7B	PT8B	PT9B	PT10B	PT12B	PT15B	I/O
186	PT5A	PT6A	PT7A	PT8A	PT9A	PT10A	PT12A	PT15A	I/O-D2
187	VSS	VSS	VSS	VSS	VSS	VSS	VSS	VSS	VSS
188	PT4D	PT5D	PT6D	PT7D	PT8D	PT9D	PT11D	PT14D	I/O-D1
189	PT4C	PT5C	PT6C	PT7C	PT8C	PT9C	PT11A	PT14A	I/O
190	PT4B	PT5B	PT6B	PT7B	PT8B	PT9B	PT10D	PT13D	I/O
191	PT4A	PT5A	PT6A	PT7A	PT8A	PT9A	PT10A	PT13A	I/O-D0/DIN
192	PT3D	PT4D	PT5D	PT6D	PT7D	PT8D	PT9D	PT12D	I/O
193	PT3C	PT4C	PT5C	PT6C	PT7C	PT8C	PT9A	PT12A	I/O
194	PT3B	PT4B	PT5B	PT6B	PT7B	PT8B	PT8D	PT11D	I/O
195	PT3A	PT4A	PT5A	PT6A	PT7A	PT8A	PT8A	PT11A	I/O-DOUT
196	VDD	VDD	VDD	VDD	VDD	VDD	VDD	VDD	VDD
197	PT2D	PT3D	PT4D	PT5D	PT6D	PT7D	PT7D	PT10D	I/O
198	PT2C	PT3C	PT4C	PT5A	PT6A	PT7A	PT7A	PT9A	I/O
199	PT2B	PT3B	PT4B	PT4D	PT5C	PT6C	PT6C	PT8A	I/O
200	PT2A	PT3A	PT4A	PT4A	PT5A	PT6A	PT6A	PT7A	I/O-TDI
201	See Note	PT2D	PT3D	PT3D	PT4A	PT5A	PT5A	PT6A	I/O
202	PT1D	PT2A	PT3A	PT3A	PT3A	PT4A	PT4A	PT5A	I/O-TMS
203	See Note	PT1D	PT2D	PT2D	PT2C	PT3A	PT3A	PT4A	I/O
204	PT1C	PT1C	PT2A	PT2A	PT2A	PT2A	PT2A	PT3A	I/O
205	PT1B	PT1B	PT1D	PT1D	PT1D	PT1D	PT1D	PT2D	I/O
206	PT1A	PT1A	PT1A	PT1A	PT1A	PT1A	PT1A	PT1A	I/O-TCK
207	VSS	VSS	VSS	VSS	VSS	VSS	VSS	VSS	VSS
208	RD_DATA/ TDO	RD_DATA/ TDO	RD_DATA/ TDO	RD_DATA/ TDO	RD_DATA/ TDO	RD_DATA/ TDO	RD_DATA/ TDO	RD_DATA/ TDO	RD_DATA/TDO

Note: The ATT2C04 does not have bond pads connected to 208-pin SQFP package pin numbers 6, 45, 47, 56, 60, 102, 153, 154, 166, 201, and 203.

Pin Information (continued)

Table 21. ATT2C06, ATT2C08, ATT2C10, ATT2C12, ATT2C15, ATT2C26, ATT2C40 and 240-Pin SQFP/SQFP-PQ2 Pinout

Pin	2C06 Pad	2C08 Pad	2C10 Pad	2C12 Pad	2C15 Pad	2C26 Pad	2C40 Pad	Function
1	VSS	VSS	VSS	VSS	VSS	VSS	VSS	VSS
2	VDD	VDD	VDD	VDD	VDD	VDD	VDD	VDD
3	PL1D	PL1D	PL1D	PL1D	PL1D	PL1D	PL1D	I/O
4	PL1C	PL1B	PL1B	PL1C	PL1C	PL1C	PL1A	I/O
5	PL1B	PL1A	PL1A	PL1B	PL1B	PL1B	PL2D	I/O
6	PL1A	PL2D	PL2D	PL2D	PL2D	PL2D	PL3D	I/O-A0
7	VSS	VSS	VSS	VSS	VSS	VSS	VSS	VSS
8	PL2D	PL3D	PL3D	PL3D	PL4D	PL4D	PL5D	I/O
9	PL2C	PL3C	PL3C	PL3A	PL4A	PL4A	PL6D	I/O
10	PL2B	PL3B	PL3B	PL4D	PL5D	PL5D	PL7D	I/O
11	PL2A	PL3A	PL3A	PL4A	PL5A	PL5A	PL8D	I/O-A1
12	PL3D	PL4D	PL4A	PL5A	PL6A	PL6A	PL9A	I/O-A2
13	PL3C	PL4C	PL5C	PL6D	PL7D	PL7D	PL10D	I/O
14	PL3B	PL4B	PL5B	PL6B	PL7B	PL7B	PL10B	I/O
15	PL3A	PL4A	PL5A	PL6A	PL7A	PL7A	PL10A	I/O-A3
16	VDD	VDD	VDD	VDD	VDD	VDD	VDD	VDD
17	PL4D	PL5D	PL6D	PL7D	PL8D	PL8D	PL11D	I/O
18	PL4C	PL5C	PL6C	PL7C	PL8C	PL8A	PL11A	I/O
19	PL4B	PL5B	PL6B	PL7B	PL8B	PL9D	PL12D	I/O
20	PL4A	PL5A	PL6A	PL7A	PL8A	PL9A	PL12A	I/O-A4
21	PL5D	PL6D	PL7D	PL8D	PL9D	PL10D	PL13D	I/O-A5
22	PL5C	PL6C	PL7C	PL8C	PL9C	PL10A	PL13A	I/O
23	PL5B	PL6B	PL7B	PL8B	PL9B	PL11D	PL14D	I/O
24	PL5A	PL6A	PL7A	PL8A	PL9A	PL11A	PL14A	I/O-A6
25	VSS	VSS	VSS	VSS	VSS	VSS	VSS	VSS
26	PL6D	PL7D	PL8D	PL9D	PL10D	PL12D	PL15D	I/O
27	PL6C	PL7C	PL8C	PL9C	PL10C	PL12C	PL15C	I/O
28	PL6B	PL7B	PL8B	PL9B	PL10B	PL12B	PL15B	I/O
29	PL6A	PL7A	PL8A	PL9A	PL10A	PL12A	PL15A	I/O-A7
30	VDD	VDD	VDD	VDD	VDD	VDD	VDD	VDD
31	PL7D	PL8D	PL9D	PL10D	PL11D	PL13D	PL16D	I/O
32	PL7C	PL8C	PL9C	PL10C	PL11C	PL13C	PL16C	I/O
33	PL7B	PL8B	PL9B	PL10B	PL11B	PL13B	PL16B	I/O
34	PL7A	PL8A	PL9A	PL10A	PL11A	PL13A	PL16A	I/O-A8
35	VSS	VSS	VSS	VSS	VSS	VSS	VSS	VSS
36	PL8D	PL9D	PL10D	PL11D	PL12D	PL14D	PL17D	I/O-A9
37	PL8C	PL9C	PL10C	PL11C	PL12C	PL14A	PL17A	I/O
38	PL8B	PL9B	PL10B	PL11B	PL12B	PL15D	PL18D	I/O
39	PL8A	PL9A	PL10A	PL11A	PL12A	PL15A	PL18A	I/O-A10
40	PL9D	PL10D	PL11D	PL12D	PL13D	PL16D	PL19D	I/O
41	PL9C	PL10C	PL11C	PL12C	PL13C	PL16A	PL19A	I/O
42	PL9B	PL10B	PL11B	PL12B	PL13B	PL17D	PL20D	I/O
43	PL9A	PL10A	PL11A	PL12A	PL13A	PL17A	PL20A	I/O-A11
44	VDD	VDD	VDD	VDD	VDD	VDD	VDD	VDD

Note: The ATT2C08 and ATT2C10 do not have bond pads connected to 240-pin SQFP package pin numbers 113 and 188.

Pin Information (continued)

Table 21. ATT2C06, ATT2C08, ATT2C10, ATT2C12, ATT2C15, ATT2C26, ATT2C40 and 240-Pin SQFP/SQFP-PQ2 Pinout (continued)

Pin	2C06 Pad	2C08 Pad	2C10 Pad	2C12 Pad	2C15 Pad	2C26 Pad	2C40 Pad	Function
45	PL10D	PL11D	PL12D	PL13D	PL14D	PL18D	PL21D	I/O-A12
46	PL10C	PL11C	PL12C	PL13B	PL14B	PL18B	PL21B	I/O
47	PL10B	PL11B	PL12B	PL14D	PL15D	PL19D	PL22D	I/O
48	PL10A	PL11A	PL13D	PL14B	PL15B	PL19B	PL22B	I/O-A13
49	PL11D	PL12D	PL13B	PL14A	PL15A	PL19A	PL22A	I/O
50	PL11C	PL12C	PL13A	PL15D	PL16D	PL20D	PL23D	I/O
51	PL11B	PL12B	PL14D	PL15B	PL16B	PL20B	PL24D	I/O
52	PL11A	PL12A	PL14C	PL16D	PL17D	PL21D	PL25A	I/O-A14
53	VSS	VSS	VSS	VSS	VSS	VSS	VSS	VSS
54	PL12D	PL13D	PL15D	PL17D	PL18D	PL22D	PL27D	I/O
55	PL12C	PL13A	PL15A	PL17A	PL19D	PL23D	PL28D	I/O
56	PL12B	PL14D	PL16D	PL18C	PL19A	PL23A	PL28A	I/O
57	PL12A	PL14A	PL16A	PL18A	PL20A	PL24A	PL30A	I/O-A15
58	VSS	VSS	VSS	VSS	VSS	VSS	VSS	VSS
59	CCLK	CCLK	CCLK	CCLK	CCLK	CCLK	CCLK	CCLK
60	VDD	VDD	VDD	VDD	VDD	VDD	VDD	VDD
61	VSS	VSS	VSS	VSS	VSS	VSS	VSS	VSS
62	VSS	VSS	VSS	VSS	VSS	VSS	VSS	VSS
63	PB1A	PB1A	PB1A	PB1A	PB1A	PB1A	PB1A	I/O-A16
64	PB1B	PB1D	PB1D	PB1D	PB2A	PB2A	PB3A	I/O
65	PB1C	PB2A	PB2A	PB2A	PB2D	PB2D	PB3D	I/O
66	PB1D	PB2D	PB2D	PB2D	PB3D	PB3D	PB4D	I/O
67	VSS	VSS	VSS	VSS	VSS	VSS	VSS	VSS
68	PB2A	PB3A	PB3B	PB3D	PB4D	PB4D	PB5D	I/O-A17
69	PB2B	PB3B	PB4B	PB4D	PB5D	PB5D	PB6D	I/O
70	PB2C	PB3C	PB4C	PB5A	PB6A	PB6A	PB7A	I/O
71	PB2D	PB3D	PB4D	PB5B	PB6B	PB6B	PB7D	I/O
72	PB3A	PB4A	PB5A	PB5D	PB6D	PB6D	PB8D	I/O
73	PB3B	PB4B	PB5B	PB6A	PB7A	PB7A	PB9A	I/O
74	PB3C	PB4C	PB5C	PB6B	PB7B	PB7B	PB9D	I/O
75	PB3D	PB4D	PB5D	PB6D	PB7D	PB7D	PB10D	I/O
76	VDD	VDD	VDD	VDD	VDD	VDD	VDD	VDD
77	PB4A	PB5A	PB6A	PB7A	PB8A	PB8A	PB11A	I/O
78	PB4B	PB5B	PB6B	PB7B	PB8B	PB8D	PB11D	I/O
79	PB4C	PB5C	PB6C	PB7C	PB8C	PB9A	PB12A	I/O
80	PB4D	PB5D	PB6D	PB7D	PB8D	PB9D	PB12D	I/O
81	PB5A	PB6A	PB7A	PB8A	PB9A	PB10A	PB13A	I/O
82	PB5B	PB6B	PB7B	PB8B	PB9B	PB10D	PB13D	I/O
83	PB5C	PB6C	PB7C	PB8C	PB9C	PB11A	PB14A	I/O
84	PB5D	PB6D	PB7D	PB8D	PB9D	PB11D	PB14D	I/O
85	VSS	VSS	VSS	VSS	VSS	VSS	VSS	VSS
86	PB6A	PB7A	PB8A	PB9A	PB10A	PB12A	PB15A	I/O
87	PB6B	PB7B	PB8B	PB9B	PB10B	PB12B	PB15B	I/O
88	PB6C	PB7C	PB8C	PB9C	PB10C	PB12C	PB15C	I/O

Note: The ATT2C08 and ATT2C10 do not have bond pads connected to 240-pin SQFP package pin numbers 113 and 188.

Pin Information (continued)

Table 21. ATT2C06, ATT2C08, ATT2C10, ATT2C12, ATT2C15, ATT2C26, ATT2C40 and 240-Pin SQFP/SQFP-PQ2 Pinout (continued)

Pin	2C06 Pad	2C08 Pad	2C10 Pad	2C12 Pad	2C15 Pad	2C26 Pad	2C40 Pad	Function
89	PB6D	PB7D	PB8D	PB9D	PB10D	PB12D	PB15D	I/O
90	VSS	VSS	VSS	VSS	VSS	VSS	VSS	VSS
91	PB7A	PB8A	PB9A	PB10A	PB11A	PB13A	PB16A	I/O
92	PB7B	PB8B	PB9B	PB10B	PB11B	PB13B	PB16B	I/O
93	PB7C	PB8C	PB9C	PB10C	PB11C	PB13C	PB16C	I/O
94	PB7D	PB8D	PB9D	PB10D	PB11D	PB13D	PB16D	I/O
95	VSS	VSS	VSS	VSS	VSS	VSS	VSS	VSS
96	PB8A	PB9A	PB10A	PB11A	PB12A	PB14A	PB17A	I/O
97	PB8B	PB9B	PB10B	PB11B	PB12B	PB14D	PB17D	I/O
98	PB8C	PB9C	PB10C	PB11C	PB12C	PB15A	PB18A	I/O
99	PB8D	PB9D	PB10D	PB11D	PB12D	PB15D	PB18D	I/O
100	PB9A	PB10A	PB11A	PB12A	PB13A	PB16A	PB19A	I/O-HDC
101	PB9B	PB10B	PB11B	PB12B	PB13B	PB16D	PB19D	I/O
102	PB9C	PB10C	PB11C	PB12C	PB13C	PB17A	PB20A	I/O
103	PB9D	PB10D	PB11D	PB12D	PB13D	PB17D	PB20D	I/O
104	VDD	VDD	VDD	VDD	VDD	VDD	VDD	VDD
105	PB10A	PB11A	PB12A	PB13A	PB14A	PB18A	PB21A	I/O-LDC
106	PB10B	PB11D	PB13A	PB13D	PB14D	PB18D	PB22D	I/O
107	PB10C	PB12A	PB13B	PB14A	PB15A	PB19A	PB23A	I/O
108	PB10D	PB12B	PB13C	PB14D	PB15D	PB19D	PB24D	I/O
109	PB11A	PB12C	PB13D	PB15A	PB16A	PB20A	PB25A	I/O-INIT
110	PB11B	PB12D	PB14A	PB15D	PB16D	PB20D	PB25D	I/O
111	PB11C	PB13A	PB15A	PB16A	PB17A	PB21A	PB26A	I/O
112	PB11D	PB13B	PB15B	PB16D	PB17D	PB21D	PB26D	I/O
113	VSS	See Note	See Note	VSS	VSS	VSS	VSS	VSS
114	PB12A	PB13D	PB15D	PB17A	PB18A	PB22A	PB27A	I/O
115	PB12B	PB14A	PB16A	PB17D	PB19A	PB23A	PB28A	I/O
116	PB12C	PB14B	PB16B	PB18A	PB19D	PB23D	PB28D	I/O
117	PB12D	PB14D	PB16D	PB18D	PB20D	PB24D	PB30D	I/O
118	VSS	VSS	VSS	VSS	VSS	VSS	VSS	VSS
119	DONE	DONE	DONE	DONE	DONE	DONE	DONE	DONE
120	VDD	VDD	VDD	VDD	VDD	VDD	VDD	VDD
121	VSS	VSS	VSS	VSS	VSS	VSS	VSS	VSS
122	RESET	RESET	RESET	RESET	RESET	RESET	RESET	RESET
123	PRGM	PRGM	PRGM	PRGM	PRGM	PRGM	PRGM	PRGM
124	PR12A	PR14A	PR16A	PR18A	PR20A	PR24A	PR30A	I/O-M0
125	PR12B	PR14D	PR16D	PR18C	PR20D	PR24D	PR29D	I/O
126	PR12C	PR13A	PR15A	PR18D	PR19A	PR23A	PR28A	I/O
127	PR12D	PR13D	PR15D	PR17B	PR18A	PR22A	PR27A	I/O
128	VSS	VSS	VSS	VSS	VSS	VSS	VSS	VSS
129	PR11A	PR12A	PR14A	PR16A	PR17A	PR21A	PR26A	I/O
130	PR11B	PR12B	PR14C	PR16D	PR17D	PR21D	PR25A	I/O
131	PR11C	PR12C	PR14D	PR15A	PR16A	PR20A	PR24A	I/O
132	PR11D	PR12D	PR13A	PR15C	PR16C	PR20C	PR24D	I/O

Note: The ATT2C08 and ATT2C10 do not have bond pads connected to 240-pin SQFP package pin numbers 113 and 188.

2

Pin Information (continued)

Table 21. ATT2C06, ATT2C08, ATT2C10, ATT2C12, ATT2C15, ATT2C26, ATT2C40 and 240-Pin SQFP/SQFP-PQ2 Pinout (continued)

Pin	2C06 Pad	2C08 Pad	2C10 Pad	2C12 Pad	2C15 Pad	2C26 Pad	2C40 Pad	Function
133	PR10A	PR11A	PR13B	PR15D	PR16D	PR20D	PR23D	I/O-M1
134	PR10B	PR11B	PR13C	PR14A	PR15A	PR19A	PR22A	I/O
135	PR10C	PR11C	PR12A	PR14D	PR15D	PR19D	PR22D	I/O
136	PR10D	PR11D	PR12B	PR13A	PR14A	PR18A	PR21A	I/O
137	VDD	VDD	VDD	VDD	VDD	VDD	VDD	VDD
138	PR9A	PR10A	PR11A	PR12A	PR13A	PR17A	PR20A	I/O-M2
139	PR9B	PR10B	PR11B	PR12B	PR13B	PR17D	PR20D	I/O
140	PR9C	PR10C	PR11C	PR12C	PR13C	PR16A	PR19A	I/O
141	PR9D	PR10D	PR11D	PR12D	PR13D	PR16D	PR19D	I/O
142	PR8A	PR9A	PR10A	PR11A	PR12A	PR15A	PR18A	I/O-M3
143	PR8B	PR9B	PR10B	PR11B	PR12B	PR15D	PR18D	I/O
144	PR8C	PR9C	PR10C	PR11C	PR12C	PR14A	PR17A	I/O
145	PR8D	PR9D	PR10D	PR11D	PR12D	PR14D	PR17D	I/O
146	VSS	VSS	VSS	VSS	VSS	VSS	VSS	VSS
147	PR7A	PR8A	PR9A	PR10A	PR11A	PR13A	PR16A	I/O
148	PR7B	PR8B	PR9B	PR10B	PR11B	PR13B	PR16B	I/O
149	PR7C	PR8C	PR9C	PR10C	PR11C	PR13C	PR16C	I/O
150	PR7D	PR8D	PR9D	PR10D	PR11D	PR13D	PR16D	I/O
151	VDD	VDD	VDD	VDD	VDD	VDD	VDD	VDD
152	PR6A	PR7A	PR8A	PR9A	PR10A	PR12A	PR15A	I/O
153	PR6B	PR7B	PR8B	PR9B	PR10B	PR12B	PR15B	I/O
154	PR6C	PR7C	PR8C	PR9C	PR10C	PR12C	PR15C	I/O
155	PR6D	PR7D	PR8D	PR9D	PR10D	PR12D	PR15D	I/O
156	VSS	VSS	VSS	VSS	VSS	VSS	VSS	VSS
157	PR5A	PR6A	PR7A	PR8A	PR9A	PR11A	PR14A	I/O
158	PR5B	PR6B	PR7B	PR8B	PR9B	PR11D	PR14D	I/O
159	PR5C	PR6C	PR7C	PR8C	PR9C	PR10A	PR13A	I/O
160	PR5D	PR6D	PR7D	PR8D	PR9D	PR10D	PR13D	I/O
161	PR4A	PR5A	PR6A	PR7A	PR8A	PR9A	PR12A	I/O-CS1
162	PR4B	PR5B	PR6B	PR7B	PR8B	PR9D	PR12D	I/O
163	PR4C	PR5C	PR6C	PR7C	PR8C	PR8A	PR11A	I/O
164	PR4D	PR5D	PR6D	PR7D	PR8D	PR8D	PR11D	I/O
165	VDD	VDD	VDD	VDD	VDD	VDD	VDD	VDD
166	PR3A	PR4A	PR5A	PR6A	PR7A	PR7A	PR10A	I/O-CS0
167	PR3B	PR4B	PR4B	PR6B	PR7B	PR7B	PR10B	I/O
168	PR3C	PR4C	PR4C	PR5B	PR6B	PR6B	PR9B	I/O
169	PR3D	PR4D	PR4D	PR5D	PR6D	PR6D	PR9D	I/O
170	PR2A	PR3A	PR3A	PR4A	PR5A	PR5A	PR8A	I/O-RD
171	PR2B	PR3B	PR3B	PR4B	PR5B	PR5B	PR7A	I/O
172	PR2C	PR3C	PR3C	PR4D	PR5D	PR5D	PR6A	I/O
173	PR2D	PR3D	PR3D	PR3A	PR4A	PR4A	PR5A	I/O
174	VSS	VSS	VSS	VSS	VSS	VSS	VSS	VSS
175	PR1A	PR2A	PR2A	PR2A	PR3A	PR3A	PR4A	I/O-WR
176	PR1B	PR2D	PR2D	PR2C	PR2A	PR2A	PR3A	I/O

Note: The ATT2C08 and ATT2C10 do not have bond pads connected to 240-pin SQFP package pin numbers 113 and 188.

Pin Information (continued)

Table 21. ATT2C06, ATT2C08, ATT2C10, ATT2C12, ATT2C15, ATT2C26, ATT2C40 and 240-Pin SQFP/SQFP-PQ2 Pinout (continued)

Pin	2C06 Pad	2C08 Pad	2C10 Pad	2C12 Pad	2C15 Pad	2C26 Pad	2C40 Pad	Function
177	PR1C	PR1A	PR1A	PR1A	PR1A	PR1A	PR2A	I/O
178	PR1D	PR1D	PR1D	PR1D	PR1D	PR1D	PR1D	I/O
179	VSS	VSS	VSS	VSS	VSS	VSS	VSS	VSS
180	RD_CFGN	RD_CFGN	RD_CFGN	RD_CFGN	RD_CFGN	RD_CFGN	RD_CFGN	RD_CFGN
181	VSS	VSS	VSS	VSS	VSS	VSS	VSS	VSS
182	VDD	VDD	VDD	VDD	VDD	VDD	VDD	VDD
183	VSS	VSS	VSS	VSS	VSS	VSS	VSS	VSS
184	PT12D	PT14D	PT16D	PT18D	PT20D	PT24D	PT30D	I/O
185	PT12C	PT14C	PT16C	PT18B	PT20A	PT24A	PT29A	I/O
186	PT12B	PT14A	PT16A	PT18A	PT19D	PT23D	PT28D	I/O
187	PT12A	PT13D	PT15D	PT17D	PT19A	PT23A	PT28A	I/O-RDY/RCLK
188	VSS	See Note	See Note	VSS	VSS	VSS	VSS	VSS
189	PT11D	PT13B	PT15B	PT16D	PT17D	PT21D	PT26D	I/O
190	PT11C	PT13A	PT15A	PT16C	PT17C	PT21C	PT26C	I/O
191	PT11B	PT12D	PT14D	PT16A	PT17A	PT21A	PT26A	I/O
192	PT11A	PT12C	PT13D	PT15D	PT16D	PT20D	PT25D	I/O-D7
193	PT10D	PT12A	PT13B	PT14D	PT15D	PT19D	PT24D	I/O
194	PT10C	PT11D	PT13A	PT14A	PT15A	PT19A	PT23D	I/O
195	PT10B	PT11C	PT12D	PT13D	PT14D	PT18D	PT22D	I/O
196	PT10A	PT11B	PT12B	PT13B	PT14B	PT18B	PT21D	I/O-D6
197	VDD	VDD	VDD	VDD	VDD	VDD	VDD	VDD
198	PT9D	PT10D	PT11D	PT12D	PT13D	PT17D	PT20D	I/O
199	PT9C	PT10C	PT11C	PT12C	PT13C	PT17A	PT20A	I/O
200	PT9B	PT10B	PT11B	PT12B	PT13B	PT16D	PT19D	I/O
201	PT9A	PT10A	PT11A	PT12A	PT13A	PT16A	PT19A	I/O-D5
202	PT8D	PT9D	PT10D	PT11D	PT12D	PT15D	PT18D	I/O
203	PT8C	PT9C	PT10C	PT11C	PT12C	PT15A	PT18A	I/O
204	PT8B	PT9B	PT10B	PT11B	PT12B	PT14D	PT17D	I/O
205	PT8A	PT9A	PT10A	PT11A	PT12A	PT14A	PT17A	I/O-D4
206	VSS	VSS	VSS	VSS	VSS	VSS	VSS	VSS
207	PT7D	PT8D	PT9D	PT10D	PT11D	PT13D	PT16D	I/O
208	PT7C	PT8C	PT9C	PT10C	PT11C	PT13C	PT16C	I/O
209	PT7B	PT8B	PT9B	PT10B	PT11B	PT13B	PT16B	I/O
210	PT7A	PT8A	PT9A	PT10A	PT11A	PT13A	PT16A	I/O-D3
211	VSS	VSS	VSS	VSS	VSS	VSS	VSS	VSS
212	PT6D	PT7D	PT8D	PT9D	PT10D	PT12D	PT15D	I/O
213	PT6C	PT7C	PT8C	PT9C	PT10C	PT12C	PT15C	I/O
214	PT6B	PT7B	PT8B	PT9B	PT10B	PT12B	PT15B	I/O
215	PT6A	PT7A	PT8A	PT9A	PT10A	PT12A	PT15A	I/O-D2
216	VSS	VSS	VSS	VSS	VSS	VSS	VSS	VSS
217	PT5D	PT6D	PT7D	PT8D	PT9D	PT11D	PT14D	I/O-D1
218	PT5C	PT6C	PT7C	PT8C	PT9C	PT11A	PT14A	I/O
219	PT5B	PT6B	PT7B	PT8B	PT9B	PT10D	PT13D	I/O
220	PT5A	PT6A	PT7A	PT8A	PT9A	PT10A	PT13A	I/O-D0/DIN

Note: The ATT2C08 and ATT2C10 do not have bond pads connected to 240-pin SQFP package pin numbers 113 and 188.

2

Pin Information (continued)

Table 21. ATT2C06, ATT2C08, ATT2C10, ATT2C12, ATT2C15, ATT2C26, ATT2C40 and 240-Pin SQFP/SQFP-PQ2 Pinout (continued)

Pin	2C06 Pad	2C08 Pad	2C10 Pad	2C12 Pad	2C15 Pad	2C26 Pad	2C40 Pad	Function
221	PT4D	PT5D	PT6D	PT7D	PT8D	PT9D	PT12D	I/O
222	PT4C	PT5C	PT6C	PT7C	PT8C	PT9A	PT12A	I/O
223	PT4B	PT5B	PT6B	PT7B	PT8B	PT8D	PT11D	I/O
224	PT4A	PT5A	PT6A	PT7A	PT8A	PT8A	PT11A	I/O-DOUT
225	VDD	VDD	VDD	VDD	VDD	VDD	VDD	VDD
226	PT3D	PT4D	PT5D	PT6D	PT7D	PT7D	PT10D	I/O
227	PT3C	PT4C	PT5A	PT6A	PT7A	PT7A	PT9A	I/O
228	PT3B	PT4B	PT4D	PT5C	PT6C	PT6C	PT8A	I/O
229	PT3A	PT4A	PT4A	PT5A	PT6A	PT6A	PT7A	I/O-TDI
230	PT2D	PT3D	PT3D	PT4D	PT5D	PT5D	PT6D	I/O
231	PT2C	PT3C	PT3C	PT4A	PT5A	PT5A	PT6A	I/O
232	PT2B	PT3B	PT3B	PT3D	PT4D	PT4D	PT5D	I/O
233	PT2A	PT3A	PT3A	PT3A	PT4A	PT4A	PT5A	I/O-TMS
234	VSS	VSS	VSS	VSS	VSS	VSS	VSS	VSS
235	PT1D	PT2D	PT2D	PT2C	PT3A	PT3A	PT4A	I/O
236	PT1C	PT2A	PT2A	PT2A	PT2A	PT2A	PT3A	I/O
237	PT1B	PT1D	PT1D	PT1D	PT1D	PT1D	PT2D	I/O
238	PT1A	PT1A	PT1A	PT1A	PT1A	PT1A	PT1A	I/O-TCK
239	VSS	VSS	VSS	VSS	VSS	VSS	VSS	VSS
240	RD_DATA/ TDO	RD_DATA/ TDO	RD_DATA/ TDO	RD_DATA/ TDO	RD_DATA/ TDO	RD_DATA/ TDO	RD_DATA/ TDO	RD_DATA/TDO

Note: The ATT2C08 and ATT2C10 do not have bond pads connected to 240-pin SQFP package pin numbers 113 and 188.

2

Pin Information (continued)

Table 22. ATT2C08, ATT2C10, and ATT2C12 256-Pin PBGA Pinout

Pin	2C08 Pad	2C10 Pad	2C12 Pad	Function
A1	Vss	Vss	Vss	Vss
B1	Vdd	Vdd	Vdd	Vdd
C2	PL1D	PL1D	PL1D	I/O
D2	PL1B	PL1B	PL1C	I/O
D3	PL1A	PL1A	PL1B	I/O
E4	PL2D	PL2D	PL2D	I/O-A0
C1	PL2C	PL2C	PL2C	I/O
D1	PL2B	PL2B	PL2B	I/O
E3	PL2A	PL2A	PL2A	I/O
D4	Vss	Vss	Vss	Vss
E2	PL3D	PL3D	PL3D	I/O
E1	PL3C	PL3C	PL3A	I/O
F3	PL3B	PL3B	PL4D	I/O
G4	PL3A	PL3A	PL4A	I/O-A1
D8	Vss	Vss	Vss	Vss
F2	—	PL4D	PL5D	I/O
F1	PL4D	PL4A	PL5A	I/O-A2
G3	PL4C	PL5C	PL6D	I/O
G2	PL4B	PL5B	PL6B	I/O
G1	PL4A	PL5A	PL6A	I/O-A3
D6	Vdd	Vdd	Vdd	Vdd
H3	PL5D	PL6D	PL7D	I/O
H2	PL5C	PL6C	PL7C	I/O
H1	PL5B	PL6B	PL7B	I/O
J4	PL5A	PL6A	PL7A	I/O-A4
J3	PL6D	PL7D	PL8D	I/O-A5
J2	PL6C	PL7C	PL8C	I/O
J1	PL6B	PL7B	PL8B	I/O
K2	PL6A	PL7A	PL8A	I/O-A6
D13	Vss	Vss	Vss	Vss
K3	PL7D	PL8D	PL9D	I/O
K1	PL7C	PL8C	PL9C	I/O
L1	PL7B	PL8B	PL9B	I/O
L2	PL7A	PL8A	PL9A	I/O-A7
D11	Vdd	Vdd	Vdd	Vdd
L3	PL8D	PL9D	PL10D	I/O
L4	PL8C	PL9C	PL10C	I/O
M1	PL8B	PL9B	PL10B	I/O
M2	PL8A	PL9A	PL10A	I/O-A8
D17	Vss	Vss	Vss	Vss
M3	PL9D	PL10D	PL11D	I/O-A9
M4	PL9C	PL10C	PL11C	I/O
N1	PL9B	PL10B	PL11B	I/O

Pin	2C08 Pad	2C10 Pad	2C12 Pad	Function
N2	PL9A	PL10A	PL11A	I/O-A10
N3	PL10D	PL11D	PL12D	I/O
P1	PL10C	PL11C	PL12C	I/O
P2	PL10B	PL11B	PL12B	I/O
R1	PL10A	PL11A	PL12A	I/O-A11
D15	Vdd	Vdd	Vdd	Vdd
P3	PL11D	PL12D	PL13D	I/O-A12
R2	PL11C	PL12C	PL13B	I/O
T1	PL11B	PL12B	PL14D	I/O
P4	PL11A	PL13D	PL14B	I/O-A13
R3	PL12D	PL13B	PL14A	I/O
H4	Vss	Vss	Vss	Vss
T2	PL12C	PL13A	PL15D	I/O
W3	—	—	—	No Connect
U1	PL12B	PL14D	PL15B	I/O
T3	PL12A	PL14C	PL16D	I/O-A14
H17	Vss	Vss	Vss	Vss
U2	PL13D	PL15D	PL17D	I/O
V1	PL13C	PL15C	PL17C	I/O
T4	PL13B	PL15B	PL17B	I/O
U3	PL13A	PL15A	PL17A	I/O
V2	PL14D	PL16D	PL18D	I/O
W1	PL14C	PL16C	PL18C	I/O
V3	PL14B	PL16B	PL18B	I/O
W2	PL14A	PL16A	PL18A	I/O-A15
N4	Vss	Vss	Vss	Vss
Y1	CCLK	CCLK	CCLK	CCLK
F4	Vdd	Vdd	Vdd	Vdd
N17	Vss	Vss	Vss	Vss
F17	Vdd	Vdd	Vdd	Vdd
Y2	PB1A	PB1A	PB1A	I/O-A16
W4	PB1C	PB1C	PB1C	I/O
V4	PB1D	PB1D	PB1D	I/O
U5	PB2A	PB2A	PB2A	I/O
Y3	PB2B	PB2B	PB2B	I/O
Y4	PB2C	PB2C	PB2C	I/O
V5	PB2D	PB2D	PB2D	I/O
U4	Vss	Vss	Vss	Vss
W5	PB3A	PB3B	PB3D	I/O-A17
U8	Vss	Vss	Vss	Vss
Y5	PB3B	PB4B	PB4D	I/O
V6	PB3C	PB4C	PB5A	I/O
U7	PB3D	PB4D	PB5B	I/O

Notes:

The W3 pin on the 256-pin PBGA package is unconnected for all devices listed in this table.

The ATT2C08 does not have bond pads connected to the 256-pin PBGA package pins F2 and Y17.

A 4 x 4 array of thermal balls is found at the center of the package. The balls can be attached to the ground plane of the board for enhanced thermal capability (see Table 26) or left unconnected.

Pin Information (continued)

Table 22. ATT2C08, ATT2C10, and ATT2C12 256-Pin PBGA Pinout (continued)

Pin	2C08 Pad	2C10 Pad	2C12 Pad	Function
W6	PB4A	PB5A	PB5D	I/O
Y6	PB4B	PB5B	PB6A	I/O
V7	PB4C	PB5C	PB6B	I/O
W7	PB4D	PB5D	PB6D	I/O
K4	VDD	VDD	VDD	VDD
Y7	PB5A	PB6A	PB7A	I/O
V8	PB5B	PB6B	PB7B	I/O
W8	PB5C	PB6C	PB7C	I/O
Y8	PB5D	PB6D	PB7D	I/O
U9	PB6A	PB7A	PB8A	I/O
V9	PB6B	PB7B	PB8B	I/O
W9	PB6C	PB7C	PB8C	I/O
Y9	PB6D	PB7D	PB8D	I/O
U13	VSS	VSS	VSS	VSS
W10	PB7A	PB8A	PB9A	I/O
V10	PB7B	PB8B	PB9B	I/O
Y10	PB7C	PB8C	PB9C	I/O
Y11	PB7D	PB8D	PB9D	I/O
U17	VSS	VSS	VSS	VSS
W11	PB8A	PB9A	PB10A	I/O
V11	PB8B	PB9B	PB10B	I/O
U11	PB8C	PB9C	PB10C	I/O
Y12	PB8D	PB9D	PB10D	I/O
W12	PB9A	PB10A	PB11A	I/O
V12	PB9B	PB10B	PB11B	I/O
U12	PB9C	PB10C	PB11C	I/O
Y13	PB9D	PB10D	PB11D	I/O
W13	PB10A	PB11A	PB12A	I/O-HDC
V13	PB10B	PB11B	PB12B	I/O
Y14	PB10C	PB11C	PB12C	I/O
W14	PB10D	PB11D	PB12D	I/O
L17	VDD	VDD	VDD	VDD
Y15	PB11A	PB12A	PB13A	I/O-LDC
V14	PB11B	PB12C	PB13B	I/O
W15	PB11C	PB12D	PB13C	I/O
Y16	PB11D	PB13A	PB13D	I/O
U14	PB12A	PB13B	PB14A	I/O
V15	PB12B	PB13C	PB14D	I/O
W16	PB12C	PB13D	PB15A	I/O-INIT
Y17	—	PB14A	PB15D	I/O
V16	PB12D	PB14B	PB16A	I/O
W17	PB13A	PB15A	PB16D	I/O
Y18	PB13B	PB15B	PB17A	I/O

Pin	2C08 Pad	2C10 Pad	2C12 Pad	Function
U16	PB13C	PB15C	PB17C	I/O
V17	PB13D	PB15D	PB17D	I/O
W18	PB14A	PB16A	PB18A	I/O
Y19	PB14B	PB16B	PB18B	I/O
V18	PB14C	PB16C	PB18C	I/O
W19	PB14D	PB16D	PB18D	I/O
Y20	DONE	DONE	DONE	DONE
R4	VDD	VDD	VDD	VDD
W20	RESET	RESET	RESET	RESET
V19	PRGM	PRGM	PRGM	PRGM
U19	PR14A	PR16A	PR18A	I/O-M0
U18	PR14C	PR16C	PR18C	I/O
T17	PR14D	PR16D	PR18D	I/O
V20	PR13A	PR15A	PR17A	I/O
U20	PR13B	PR15B	PR17B	I/O
T18	PR13C	PR15C	PR17C	I/O
T19	PR13D	PR15D	PR17D	I/O
T20	PR12A	PR14A	PR16A	I/O
R18	PR12B	PR14C	PR16D	I/O
P17	PR12C	PR14D	PR15A	I/O
R19	PR12D	PR13A	PR15C	I/O
R20	PR11A	PR13B	PR15D	I/O-M1
P18	PR11B	PR13C	PR14A	I/O
P19	PR11C	PR12A	PR14D	I/O
P20	PR11D	PR12B	PR13A	I/O
R17	VDD	VDD	VDD	VDD
N18	PR10A	PR11A	PR12A	I/O-M2
N19	PR10B	PR11B	PR12B	I/O
N20	PR10C	PR11C	PR12C	I/O
M17	PR10D	PR11D	PR12D	I/O
M18	PR9A	PR10A	PR11A	I/O-M3
M19	PR9B	PR10B	PR11B	I/O
M20	PR9C	PR10C	PR11C	I/O
L19	PR9D	PR10D	PR11D	I/O
L18	PR8A	PR9A	PR10A	I/O
L20	PR8B	PR9B	PR10B	I/O
K20	PR8C	PR9C	PR10C	I/O
K19	PR8D	PR9D	PR10D	I/O
U6	VDD	VDD	VDD	VDD
K18	PR7A	PR8A	PR9A	I/O
K17	PR7B	PR8B	PR9B	I/O
J20	PR7C	PR8C	PR9C	I/O
J19	PR7D	PR8D	PR9D	I/O

Notes:

The W3 pin on the 256-pin PBGA package is unconnected for all devices listed in this table.

The ATT2C08 does not have bond pads connected to the 256-pin PBGA package pins F2 and Y17.

A 4 x 4 array of thermal balls is found at the center of the package. The balls can be attached to the ground plane of the board for enhanced thermal capability (see Table 26) or left unconnected.

Lucent Technologies Inc.

Pin Information (continued)

Table 22. ATT2C08, ATT2C10, and ATT2C12 256-Pin PBGA Pinout (continued)

Pin	2C08 Pad	2C10 Pad	2C12 Pad	Function
J18	PR6A	PR7A	PR8A	I/O
J17	PR6B	PR7B	PR8B	I/O
H20	PR6C	PR7C	PR8C	I/O
H19	PR6D	PR7D	PR8D	I/O
H18	PR5A	PR6A	PR7A	I/O-CS1
G20	PR5B	PR6B	PR7B	I/O
G19	PR5C	PR6C	PR7C	I/O
F20	PR5D	PR6D	PR7D	I/O
U10	VDD	VDD	VDD	VDD
G18	PR4A	PR5A	PR6A	I/O-CS0
F19	PR4B	PR4B	PR6B	I/O
E20	PR4C	PR4C	PR5B	I/O
G17	PR4D	PR4D	PR5D	I/O
F18	PR3A	PR3A	PR4A	I/O-RD
E19	PR3B	PR3B	PR4B	I/O
D20	PR3C	PR3C	PR4D	I/O
E18	PR3D	PR3D	PR3A	I/O
D19	PR2A	PR2A	PR2A	I/O-WR
C20	PR2B	PR2B	PR2B	I/O
E17	PR2C	PR2C	PR2C	I/O
D18	PR2D	PR2D	PR2D	I/O
C19	PR1A	PR1A	PR1A	I/O
B20	PR1B	PR1B	PR1B	I/O
C18	PR1C	PR1C	PR1C	I/O
B19	PR1D	PR1D	PR1D	I/O
A20	RD_CFGN	RD_CFGN	RD_CFGN	RD_CFGN
U15	VDD	VDD	VDD	VDD
A19	PT14D	PT16D	PT18D	I/O
B18	PT14C	PT16C	PT18C	I/O
B17	PT14B	PT16B	PT18B	I/O
C17	PT14A	PT16A	PT18A	I/O
D16	PT13D	PT15D	PT17D	I/O-RDY/ RCLK
A18	PT13C	PT15C	PT17A	I/O
A17	PT13B	PT15B	PT16D	I/O
C16	PT13A	PT15A	PT16C	I/O
B16	PT12D	PT14D	PT16A	I/O
A16	PT12C	PT13D	PT15D	I/O-D7
C15	PT12B	PT13C	PT15A	I/O
D14	PT12A	PT13B	PT14D	I/O
B15	PT11D	PT13A	PT14A	I/O
A15	PT11C	PT12D	PT13D	I/O
C14	PT11B	PT12B	PT13B	I/O-D6

Pin	2C08 Pad	2C10 Pad	2C12 Pad	Function
B14	PT11A	PT12A	PT13A	I/O
A14	PT10D	PT11D	PT12D	I/O
C13	PT10C	PT11C	PT12C	I/O
B13	PT10B	PT11B	PT12B	I/O
A13	PT10A	PT11A	PT12A	I/O-D5
D12	PT9D	PT10D	PT11D	I/O
C12	PT9C	PT10C	PT11C	I/O
B12	PT9B	PT10B	PT11B	I/O
A12	PT9A	PT10A	PT11A	I/O-D4
B11	PT8D	PT9D	PT10D	I/O
C11	PT8C	PT9C	PT10C	I/O
A11	PT8B	PT9B	PT10B	I/O
A10	PT8A	PT9A	PT10A	I/O-D3
B10	PT7D	PT8D	PT9D	I/O
C10	PT7C	PT8C	PT9C	I/O
D10	PT7B	PT8B	PT9B	I/O
A9	PT7A	PT8A	PT9A	I/O-D2
B9	PT6D	PT7D	PT8D	I/O-D1
C9	PT6C	PT7C	PT8C	I/O
D9	PT6B	PT7B	PT8B	I/O
A8	PT6A	PT7A	PT8A	I/O-DO/DIN
B8	PT5D	PT6D	PT7D	I/O
C8	PT5C	PT6C	PT7C	I/O
A7	PT5B	PT6B	PT7B	I/O
B7	PT5A	PT6A	PT7A	I/O-DOUT
A6	PT4D	PT5D	PT6D	I/O
C7	PT4C	PT5A	PT6A	I/O
B6	PT4B	PT4D	PT5C	I/O
A5	PT4A	PT4A	PT5A	I/O-TDI
D7	PT3D	PT3D	PT4D	I/O
C6	PT3C	PT3C	PT4A	I/O
B5	PT3B	PT3B	PT3D	I/O
A4	PT3A	PT3A	PT3A	I/O-TMS
C5	PT2D	PT2D	PT2D	I/O
B4	PT2C	PT2C	PT2C	I/O
A3	PT2B	PT2B	PT2B	I/O
D5	PT2A	PT2A	PT2A	I/O
C4	PT1D	PT1D	PT1D	I/O
B3	PT1C	PT1C	PT1C	I/O
B2	PT1B	PT1B	PT1B	I/O
A2	PT1A	PT1A	PT1A	I/O-TCK
C3	RD_DATA /TDO	RD_DATA /TDO	RD_DATA /TDO	RD_DATA/ TDO

Notes:

The W3 pin on the 256-pin PBGA package is unconnected for all devices listed in this table.

The ATT2C08 does not have bond pads connected to the 256-pin PBGA package pins F2 and Y17.

A 4 x 4 array of thermal balls is found at the center of the package. The balls can be attached to the ground plane of the board for enhanced thermal capability (see Table 26) or left unconnected.

Pin Information (continued)

Table 23. ATT2C08, ATT2C10, ATT2C12, ATT2C15, ATT2C26, and ATT2C40
304-Pin SQFP/SQFP-PQ2 Pinout

Pin	2C08 Pad	2C10 Pad	2C12 Pad	2C15 Pad	2C26 Pad	2C40 Pad	Function
1	Vss	Vss	Vss	Vss	Vss	Vss	Vss
2	VDD	VDD	VDD	VDD	VDD	VDD	VDD
3	Vss	Vss	Vss	Vss	Vss	Vss	Vss
4	PL1D	PL1D	PL1D	PL1D	PL1D	PL1D	I/O
5	PL1C	PL1C	PL1C	PL1C	PL1C	PL1A	I/O
6	PL1B	PL1B	PL1B	PL1B	PL1B	PL2D	I/O
7	PL1A	PL1A	PL1A	PL1A	PL1A	PL2A	I/O
8	PL2D	PL2D	PL2D	PL2D	PL2D	PL3D	I/O-A0
9	PL2C	PL2C	PL2C	PL2A	PL2A	PL3A	I/O
10	PL2B	PL2B	PL2B	PL3D	PL3D	PL4D	I/O
11	PL2A	PL2A	PL2A	PL3A	PL3A	PL4A	I/O
12	Vss	Vss	Vss	Vss	Vss	Vss	Vss
13	PL3D	PL3D	PL3D	PL4D	PL4D	PL5D	I/O
14	PL3C	PL3C	PL3A	PL4A	PL4A	PL6D	I/O
15	PL3B	PL3B	PL4D	PL5D	PL5D	PL7D	I/O
16	PL3A	PL3A	PL4A	PL5A	PL5A	PL8D	I/O-A1
17	See Note	PL4D	PL5D	PL6D	PL6D	PL9D	I/O
18	See Note	PL4C	PL5C	PL6C	PL6C	PL9C	I/O
19	See Note	PL4B	PL5B	PL6B	PL6B	PL9B	I/O
20	PL4D	PL4A	PL5A	PL6A	PL6A	PL9A	I/O-A2
21	See Note	PL5D	PL6D	PL7D	PL7D	PL10D	I/O
22	PL4C	PL5C	PL6C	PL7C	PL7C	PL10C	I/O
23	PL4B	PL5B	PL6B	PL7B	PL7B	PL10B	I/O
24	PL4A	PL5A	PL6A	PL7A	PL7A	PL10A	I/O-A3
25	VDD	VDD	VDD	VDD	VDD	VDD	VDD
26	PL5D	PL6D	PL7D	PL8D	PL8D	PL11D	I/O
27	PL5C	PL6C	PL7C	PL8C	PL8A	PL11A	I/O
28	PL5B	PL6B	PL7B	PL8B	PL9D	PL12D	I/O
29	PL5A	PL6A	PL7A	PL8A	PL9A	PL12A	I/O-A4
30	PL6D	PL7D	PL8D	PL9D	PL10D	PL13D	I/O-A5
31	PL6C	PL7C	PL8C	PL9C	PL10A	PL13A	I/O
32	PL6B	PL7B	PL8B	PL9B	PL11D	PL14D	I/O
33	PL6A	PL7A	PL8A	PL9A	PL11A	PL14A	I/O-A6
34	Vss	Vss	Vss	Vss	Vss	Vss	Vss
35	PL7D	PL8D	PL9D	PL10D	PL12D	PL15D	I/O
36	PL7C	PL8C	PL9C	PL10C	PL12C	PL15C	I/O
37	PL7B	PL8B	PL9B	PL10B	PL12B	PL15B	I/O
38	PL7A	PL8A	PL9A	PL10A	PL12A	PL15A	I/O-A7
39	VDD	VDD	VDD	VDD	VDD	VDD	VDD
40	PL8D	PL9D	PL10D	PL11D	PL13D	PL16D	I/O
41	PL8C	PL9C	PL10C	PL11C	PL13C	PL16C	I/O

Note: The ATT2C08 does not have bond pads connected to 304-pin SQFP package pin numbers 17, 18, 19, 21, 57, 59, 64, 89, 91—93, 131, 138, 140, 171, 174, 175, 206—209, 242, 243, 249, 282, 283, 286, and 287.

Pin Information (continued)

Table 23. ATT2C08, ATT2C10, ATT2C12, ATT2C15, ATT2C26, and ATT2C40
304-Pin SQFP/SQFP-PQ2 Pinout (continued)

Pin	2C08 Pad	2C10 Pad	2C12 Pad	2C15 Pad	2C26 Pad	2C40 Pad	Function
42	PL8B	PL9B	PL10B	PL11B	PL13B	PL16B	I/O
43	PL8A	PL9A	PL10A	PL11A	PL13A	PL16A	I/O-A8
44	Vss	Vss	Vss	Vss	Vss	Vss	Vss
45	PL9D	PL10D	PL11D	PL12D	PL14D	PL17D	I/O-A9
46	PL9C	PL10C	PL11C	PL12C	PL14A	PL17A	I/O
47	PL9B	PL10B	PL11B	PL12B	PL15D	PL18D	I/O
48	PL9A	PL10A	PL11A	PL12A	PL15A	PL18A	I/O-A10
49	PL10D	PL11D	PL12D	PL13D	PL16D	PL19D	I/O
50	PL10C	PL11C	PL12C	PL13C	PL16A	PL19A	I/O
51	PL10B	PL11B	PL12B	PL13B	PL17D	PL20D	I/O
52	PL10A	PL11A	PL12A	PL13A	PL17A	PL20A	I/O-A11
53	Vdd	Vdd	Vdd	Vdd	Vdd	Vdd	Vdd
54	PL11D	PL12D	PL13D	PL14D	PL18D	PL21D	I/O-A12
55	PL11C	PL12C	PL13B	PL14B	PL18B	PL21B	I/O
56	PL11B	PL12B	PL13A	PL14A	PL18A	PL21A	I/O
57	See Note	PL12A	PL14D	PL15D	PL19D	PL22D	I/O
58	PL11A	PL13D	PL14B	PL15B	PL19B	PL22B	I/O-A13
59	See Note	PL13C	PL14A	PL15A	PL19A	PL22A	I/O
60	PL12D	PL13B	PL15D	PL16D	PL20D	PL23D	I/O
61	PL12C	PL13A	PL15B	PL16B	PL20B	PL24D	I/O
62	PL12B	PL14D	PL15A	PL16A	PL20A	PL25D	I/O
63	PL12A	PL14C	PL16D	PL17D	PL21D	PL25A	I/O-A14
64	See Note	PL14A	PL16A	PL17A	PL21A	PL26A	I/O
65	Vss	Vss	Vss	Vss	Vss	Vss	Vss
66	PL13D	PL15D	PL17D	PL18D	PL22D	PL27D	I/O
67	PL13C	PL15C	PL17C	PL18C	PL22C	PL27C	I/O
68	PL13B	PL15B	PL17B	PL18A	PL22A	PL27A	I/O
69	PL13A	PL15A	PL17A	PL19D	PL23D	PL28D	I/O
70	PL14D	PL16D	PL18D	PL19C	PL23C	PL28C	I/O
71	PL14C	PL16C	PL18C	PL19A	PL23A	PL28A	I/O
72	PL14B	PL16B	PL18B	PL20D	PL24D	PL29A	I/O
73	PL14A	PL16A	PL18A	PL20A	PL24A	PL30A	I/O-A15
74	Vss	Vss	Vss	Vss	Vss	Vss	Vss
75	CCLK	CCLK	CCLK	CCLK	CCLK	CCLK	CCLK
76	Vdd	Vdd	Vdd	Vdd	Vdd	Vdd	Vdd
77	Vss	Vss	Vss	Vss	Vss	Vss	Vss
78	Vdd	Vdd	Vdd	Vdd	Vdd	Vdd	Vdd
79	Vss	Vss	Vss	Vss	Vss	Vss	Vss
80	PB1A	PB1A	PB1A	PB1A	PB1A	PB1A	I/O-A16
81	PB1B	PB1B	PB1B	PB1C	PB1C	PB2A	I/O
82	PB1C	PB1C	PB1C	PB1D	PB1D	PB2D	I/O

Note: The ATT2C08 does not have bond pads connected to 304-pin SQFP package pin numbers 17, 18, 19, 21, 57, 59, 64, 89, 91–93, 131, 138, 140, 171, 174, 175, 206–209, 242, 243, 249, 282, 283, 286, and 287.

2

Pin Information (continued)

**Table 23. ATT2C08, ATT2C10, ATT2C12, ATT2C15, ATT2C26, and ATT2C40
304-Pin SQFP/SQFP-PQ2 Pinout (continued)**

Pin	2C08 Pad	2C10 Pad	2C12 Pad	2C15 Pad	2C26 Pad	2C40 Pad	Function
83	PB1D	PB1D	PB1D	PB2A	PB2A	PB3A	I/O
84	PB2A	PB2A	PB2A	PB2D	PB2D	PB3D	I/O
85	PB2B	PB2B	PB2B	PB3A	PB3A	PB4A	I/O
86	PB2C	PB2C	PB2C	PB3C	PB3C	PB4C	I/O
87	PB2D	PB2D	PB2D	PB3D	PB3D	PB4D	I/O
88	Vss	Vss	Vss	Vss	Vss	Vss	Vss
89	See Note	PB3A	PB3A	PB4A	PB4A	PB5A	I/O
90	PB3A	PB3B	PB3D	PB4D	PB4D	PB5D	I/O-A17
91	See Note	PB3C	PB4A	PB5A	PB5A	PB6A	I/O
92	See Note	PB3D	PB4D	PB5D	PB5D	PB6D	I/O
93	See Note	PB4A	PB5A	PB6A	PB6A	PB7A	I/O
94	PB3B	PB4B	PB5B	PB6B	PB6B	PB7D	I/O
95	PB3C	PB4C	PB5C	PB6C	PB6C	PB8A	I/O
96	PB3D	PB4D	PB5D	PB6D	PB6D	PB8D	I/O
97	PB4A	PB5A	PB6A	PB7A	PB7A	PB9A	I/O
98	PB4B	PB5B	PB6B	PB7B	PB7B	PB9D	I/O
99	PB4C	PB5C	PB6C	PB7C	PB7C	PB10A	I/O
100	PB4D	PB5D	PB6D	PB7D	PB7D	PB10D	I/O
101	VDD	VDD	VDD	VDD	VDD	VDD	VDD
102	PB5A	PB6A	PB7A	PB8A	PB8A	PB11A	I/O
103	PB5B	PB6B	PB7B	PB8B	PB8D	PB11D	I/O
104	PB5C	PB6C	PB7C	PB8C	PB9A	PB12A	I/O
105	PB5D	PB6D	PB7D	PB8D	PB9D	PB12D	I/O
106	PB6A	PB7A	PB8A	PB9A	PB10A	PB13A	I/O
107	PB6B	PB7B	PB8B	PB9B	PB10D	PB13D	I/O
108	PB6C	PB7C	PB8C	PB9C	PB11A	PB14A	I/O
109	PB6D	PB7D	PB8D	PB9D	PB11D	PB14D	I/O
110	Vss	Vss	Vss	Vss	Vss	Vss	Vss
111	PB7A	PB8A	PB9A	PB10A	PB12A	PB15A	I/O
112	PB7B	PB8B	PB9B	PB10B	PB12B	PB15B	I/O
113	PB7C	PB8C	PB9C	PB10C	PB12C	PB15C	I/O
114	PB7D	PB8D	PB9D	PB10D	PB12D	PB15D	I/O
115	Vss	Vss	Vss	Vss	Vss	Vss	Vss
116	PB8A	PB9A	PB10A	PB11A	PB13A	PB16A	I/O
117	PB8B	PB9B	PB10B	PB11B	PB13B	PB16B	I/O
118	PB8C	PB9C	PB10C	PB11C	PB13C	PB16C	I/O
119	PB8D	PB9D	PB10D	PB11D	PB13D	PB16D	I/O
120	Vss	Vss	Vss	Vss	Vss	Vss	Vss
121	PB9A	PB10A	PB11A	PB12A	PB14A	PB17A	I/O
122	PB9B	PB10B	PB11B	PB12B	PB14D	PB17D	I/O
123	PB9C	PB10C	PB11C	PB12C	PB15A	PB18A	I/O

Note: The ATT2C08 does not have bond pads connected to 304-pin SQFP package pin numbers 17, 18, 19, 21, 57, 59, 64, 89, 91—93, 131, 138, 140, 171, 174, 175, 206—209, 242, 243, 249, 282, 283, 286, and 287.

Pin Information (continued)

Table 23. ATT2C08, ATT2C10, ATT2C12, ATT2C15, ATT2C26, and ATT2C40
304-Pin SQFP/SQFP-PQ2 Pinout (continued)

Pin	2C08 Pad	2C10 Pad	2C12 Pad	2C15 Pad	2C26 Pad	2C40 Pad	Function
124	PB9D	PB10D	PB11D	PB12D	PB15D	PB18D	I/O
125	PB10A	PB11A	PB12A	PB13A	PB16A	PB19A	I/O-HDC
126	PB10B	PB11B	PB12B	PB13B	PB16D	PB19D	I/O
127	PB10C	PB11C	PB12C	PB13C	PB17A	PB20A	I/O
128	PB10D	PB11D	PB12D	PB13D	PB17D	PB20D	I/O
129	VDD	VDD	VDD	VDD	VDD	VDD	VDD
130	PB11A	PB12A	PB13A	PB14A	PB18A	PB21A	I/O-LDC
131	See Note	PB12B	PB13B	PB14B	PB18B	PB21D	I/O
132	PB11B	PB12C	PB13C	PB14C	PB18C	PB22A	I/O
133	PB11C	PB12D	PB13D	PB14D	PB18D	PB22D	I/O
134	PB11D	PB13A	PB14A	PB15A	PB19A	PB23A	I/O
135	PB12A	PB13B	PB14B	PB15B	PB19B	PB24A	I/O
136	PB12B	PB13C	PB14D	PB15D	PB19D	PB24D	I/O
137	PB12C	PB13D	PB15A	PB16A	PB20A	PB25A	I/O-INIT
138	See Note	PB14A	PB15D	PB16D	PB20D	PB25D	I/O
139	PB12D	PB14B	PB16A	PB17A	PB21A	PB26A	I/O
140	See Note	PB14D	PB16D	PB17D	PB21D	PB26D	I/O
141	VSS	VSS	VSS	VSS	VSS	VSS	VSS
142	PB13A	PB15A	PB17A	PB18A	PB22A	PB27A	I/O
143	PB13B	PB15B	PB17B	PB18B	PB22B	PB27B	I/O
144	PB13C	PB15C	PB17C	PB18D	PB22D	PB27D	I/O
145	PB13D	PB15D	PB17D	PB19A	PB23A	PB28A	I/O
146	PB14A	PB16A	PB18A	PB19D	PB23D	PB28D	I/O
147	PB14B	PB16B	PB18B	PB20A	PB24A	PB29A	I/O
148	PB14C	PB16C	PB18C	PB20B	PB24B	PB29D	I/O
149	PB14D	PB16D	PB18D	PB20D	PB24D	PB30D	I/O
150	VSS	VSS	VSS	VSS	VSS	VSS	VSS
151	DONE	DONE	DONE	DONE	DONE	DONE	DONE
152	VDD	VDD	VDD	VDD	VDD	VDD	VDD
153	VSS	VSS	VSS	VSS	VSS	VSS	VSS
154	RESET	RESET	RESET	RESET	RESET	RESET	RESET
155	PRGM	PRGM	PRGM	PRGM	PRGM	PRGM	PRGM
156	PR14A	PR16A	PR18A	PR20A	PR24A	PR30A	I/O-M0
157	PR14B	PR16B	PR18B	PR20C	PR24C	PR29A	I/O
158	PR14C	PR16C	PR18C	PR20D	PR24D	PR29D	I/O
159	PR14D	PR16D	PR18D	PR19A	PR23A	PR28A	I/O
160	PR13A	PR15A	PR17A	PR19D	PR23D	PR28D	I/O
161	PR13B	PR15B	PR17B	PR18A	PR22A	PR27A	I/O
162	PR13C	PR15C	PR17C	PR18B	PR22B	PR27B	I/O
163	PR13D	PR15D	PR17D	PR18D	PR22D	PR27D	I/O
164	VSS	VSS	VSS	VSS	VSS	VSS	VSS

Note: The ATT2C08 does not have bond pads connected to 304-pin SQFP package pin numbers 17, 18, 19, 21, 57, 59, 64, 89, 91—93, 131, 138, 140, 171, 174, 175, 206—209, 242, 243, 249, 282, 283, 286, and 287.

2

Pin Information (continued)

Table 23. ATT2C08, ATT2C10, ATT2C12, ATT2C15, ATT2C26, and ATT2C40
304-Pin SQFP/SQFP-PQ2 Pinout (continued)

Pin	2C08 Pad	2C10 Pad	2C12 Pad	2C15 Pad	2C26 Pad	2C40 Pad	Function
165	PR12A	PR14A	PR16A	PR17A	PR21A	PR26A	I/O
166	PR12B	PR14C	PR16D	PR17D	PR21D	PR25A	I/O
167	PR12C	PR14D	PR15A	PR16A	PR20A	PR24A	I/O
168	PR12D	PR13A	PR15C	PR16C	PR20C	PR24D	I/O
169	PR11A	PR13B	PR15D	PR16D	PR20D	PR23D	I/O-M1
170	PR11B	PR13C	PR14A	PR15A	PR19A	PR22A	I/O
171	See Note	PR13D	PR14C	PR15C	PR19C	PR22C	I/O
172	PR11C	PR12A	PR14D	PR15D	PR19D	PR22D	I/O
173	PR11D	PR12B	PR13A	PR14A	PR18A	PR21A	I/O
174	See Note	PR12C	PR13C	PR14C	PR18C	PR21C	I/O
175	See Note	PR12D	PR13D	PR14D	PR18D	PR21D	I/O
176	VDD	VDD	VDD	VDD	VDD	VDD	VDD
177	PR10A	PR11A	PR12A	PR13A	PR17A	PR20A	I/O-M2
178	PR10B	PR11B	PR12B	PR13B	PR17D	PR20D	I/O
179	PR10C	PR11C	PR12C	PR13C	PR16A	PR19A	I/O
180	PR10D	PR11D	PR12D	PR13D	PR16D	PR19D	I/O
181	PR9A	PR10A	PR11A	PR12A	PR15A	PR18A	I/O-M3
182	PR9B	PR10B	PR11B	PR12B	PR15D	PR18D	I/O
183	PR9C	PR10C	PR11C	PR12C	PR14A	PR17A	I/O
184	PR9D	PR10D	PR11D	PR12D	PR14D	PR17D	I/O
185	VSS	VSS	VSS	VSS	VSS	VSS	VSS
186	PR8A	PR9A	PR10A	PR11A	PR13A	PR16A	I/O
187	PR8B	PR9B	PR10B	PR11B	PR13B	PR16B	I/O
188	PR8C	PR9C	PR10C	PR11C	PR13C	PR16C	I/O
189	PR8D	PR9D	PR10D	PR11D	PR13D	PR16D	I/O
190	VDD	VDD	VDD	VDD	VDD	VDD	VDD
191	PR7A	PR8A	PR9A	PR10A	PR12A	PR15A	I/O
192	PR7B	PR8B	PR9B	PR10B	PR12B	PR15B	I/O
193	PR7C	PR8C	PR9C	PR10C	PR12C	PR15C	I/O
194	PR7D	PR8D	PR9D	PR10D	PR12D	PR15D	I/O
195	VSS	VSS	VSS	VSS	VSS	VSS	VSS
196	PR6A	PR7A	PR8A	PR9A	PR11A	PR14A	I/O
197	PR6B	PR7B	PR8B	PR9B	PR11D	PR14D	I/O
198	PR6C	PR7C	PR8C	PR9C	PR10A	PR13A	I/O
199	PR6D	PR7D	PR8D	PR9D	PR10D	PR13D	I/O
200	PR5A	PR6A	PR7A	PR8A	PR9A	PR12A	I/O-CS1
201	PR5B	PR6B	PR7B	PR8B	PR9D	PR12D	I/O
202	PR5C	PR6C	PR7C	PR8C	PR8A	PR11A	I/O
203	PR5D	PR6D	PR7D	PR8D	PR8D	PR11D	I/O
204	VDD	VDD	VDD	VDD	VDD	VDD	VDD
205	PR4A	PR5A	PR6A	PR7A	PR7A	PR10A	I/O-CS0

Note: The ATT2C08 does not have bond pads connected to 304-pin SQFP package pin numbers 17, 18, 19, 21, 57, 59, 64, 89, 91—93, 131, 138, 140, 171, 174, 175, 206—209, 242, 243, 249, 282, 283, 286, and 287.

Pin Information (continued)

Table 23. ATT2C08, ATT2C10, ATT2C12, ATT2C15, ATT2C26, and ATT2C40
304-Pin SQFP/SQFP-PQ2 Pinout (continued)

Pin	2C08 Pad	2C10 Pad	2C12 Pad	2C15 Pad	2C26 Pad	2C40 Pad	Function
206	See Note	PR5B	PR6B	PR7B	PR7B	PR10B	I/O
207	See Note	PR5C	PR6C	PR7C	PR7C	PR10C	I/O
208	See Note	PR5D	PR6D	PR7D	PR7D	PR10D	I/O
209	See Note	PR4A	PR5A	PR6A	PR6A	PR9A	I/O
210	PR4B	PR4B	PR5B	PR6B	PR6B	PR9B	I/O
211	PR4C	PR4C	PR5C	PR6C	PR6C	PR9C	I/O
212	PR4D	PR4D	PR5D	PR6D	PR6D	PR9D	I/O
213	PR3A	PR3A	PR4A	PR5A	PR5A	PR8A	I/O-RD
214	PR3B	PR3B	PR4B	PR5B	PR5B	PR7A	I/O
215	PR3C	PR3C	PR4D	PR5D	PR5D	PR6A	I/O
216	PR3D	PR3D	PR3A	PR4A	PR4A	PR5A	I/O
217	Vss	Vss	Vss	Vss	Vss	Vss	Vss
218	PR2A	PR2A	PR2A	PR3A	PR3A	PR4A	I/O-WR
219	PR2B	PR2B	PR2B	PR3B	PR3B	PR4B	I/O
220	PR2C	PR2C	PR2C	PR2A	PR2A	PR3A	I/O
221	PR2D	PR2D	PR2D	PR2D	PR2D	PR3D	I/O
222	PR1A	PR1A	PR1A	PR1A	PR1A	PR2A	I/O
223	PR1B	PR1B	PR1B	PR1B	PR1B	PR2D	I/O
224	PR1C	PR1C	PR1C	PR1C	PR1C	PR1A	I/O
225	PR1D	PR1D	PR1D	PR1D	PR1D	PR1D	I/O
226	Vss	Vss	Vss	Vss	Vss	Vss	Vss
227	RD_CFGN	RD_CFGN	RD_CFGN	RD_CFGN	RD_CFGN	RD_CFGN	RD_CFGN
228	VDD	VDD	VDD	VDD	VDD	VDD	VDD
229	Vss	Vss	Vss	Vss	Vss	Vss	Vss
230	VDD	VDD	VDD	VDD	VDD	VDD	VDD
231	Vss	Vss	Vss	Vss	Vss	Vss	Vss
232	PT14D	PT16D	PT18D	PT20D	PT24D	PT30D	I/O
233	PT14C	PT16C	PT18C	PT20C	PT24C	PT30A	I/O
234	PT14B	PT16B	PT18B	PT20A	PT24A	PT29A	I/O
235	PT14A	PT16A	PT18A	PT19D	PT23D	PT28D	I/O
236	PT13D	PT15D	PT17D	PT19A	PT23A	PT28A	I/O-RDY/RCLK
237	PT13C	PT15C	PT17C	PT18D	PT22D	PT27D	I/O
238	PT13B	PT15B	PT17B	PT18C	PT22C	PT27C	I/O
239	PT13A	PT15A	PT17A	PT18A	PT22A	PT27A	I/O
240	Vss	Vss	Vss	Vss	Vss	Vss	Vss
241	PT12D	PT14D	PT16D	PT17D	PT21D	PT26D	I/O
242	See Note	PT14B	PT16C	PT17C	PT21C	PT26C	I/O
243	See Note	PT14A	PT16A	PT17A	PT21A	PT26A	I/O
244	PT12C	PT13D	PT15D	PT16D	PT20D	PT25D	I/O-D7
245	PT12B	PT13C	PT15A	PT16A	PT20A	PT25A	I/O
246	PT12A	PT13B	PT14D	PT15D	PT19D	PT24D	I/O

Note: The ATT2C08 does not have bond pads connected to 304-pin SQFP package pin numbers 17, 18, 19, 21, 57, 59, 64, 89, 91–93, 131, 138, 140, 171, 174, 175, 206–209, 242, 243, 249, 282, 283, 286, and 287.

Pin Information (continued)

Table 23. ATT2C08, ATT2C10, ATT2C12, ATT2C15, ATT2C26, and ATT2C40
304-Pin SQFP/SQFP-PQ2 Pinout (continued)

Pin	2C08 Pad	2C10 Pad	2C12 Pad	2C15 Pad	2C26 Pad	2C40 Pad	Function
247	PT11D	PT13A	PT14A	PT15A	PT19A	PT23D	I/O
248	PT11C	PT12D	PT13D	PT14D	PT18D	PT22D	I/O
249	See Note	PT12C	PT13C	PT14C	PT18C	PT22A	I/O
250	PT11B	PT12B	PT13B	PT14B	PT18B	PT21D	I/O-D6
251	PT11A	PT12A	PT13A	PT14A	PT18A	PT21A	I/O
252	VDD	VDD	VDD	VDD	VDD	VDD	VDD
253	PT10D	PT11D	PT12D	PT13D	PT17D	PT20D	I/O
254	PT10C	PT11C	PT12C	PT13C	PT17A	PT20A	I/O
255	PT10B	PT11B	PT12B	PT13B	PT16D	PT19D	I/O
256	PT10A	PT11A	PT12A	PT13A	PT16A	PT19A	I/O-D5
257	PT9D	PT10D	PT11D	PT12D	PT15D	PT18D	I/O
258	PT9C	PT10C	PT11C	PT12C	PT15A	PT18A	I/O
259	PT9B	PT10B	PT11B	PT12B	PT14D	PT17D	I/O
260	PT9A	PT10A	PT11A	PT12A	PT14A	PT17A	I/O-D4
261	VSS	VSS	VSS	VSS	VSS	VSS	VSS
262	PT8D	PT9D	PT10D	PT11D	PT13D	PT16D	I/O
263	PT8C	PT9C	PT10C	PT11C	PT13C	PT16C	I/O
264	PT8B	PT9B	PT10B	PT11B	PT13B	PT16B	I/O
265	PT8A	PT9A	PT10A	PT11A	PT13A	PT16A	I/O-D3
266	VSS	VSS	VSS	VSS	VSS	VSS	VSS
267	PT7D	PT8D	PT9D	PT10D	PT12D	PT15D	I/O
268	PT7C	PT8C	PT9C	PT10C	PT12C	PT15C	I/O
269	PT7B	PT8B	PT9B	PT10B	PT12B	PT15B	I/O
270	PT7A	PT8A	PT9A	PT10A	PT12A	PT15A	I/O-D2
271	VSS	VSS	VSS	VSS	VSS	VSS	VSS
272	PT6D	PT7D	PT8D	PT9D	PT11D	PT14D	I/O-D1
273	PT6C	PT7C	PT8C	PT9C	PT11A	PT14A	I/O
274	PT6B	PT7B	PT8B	PT9B	PT10D	PT13D	I/O
275	PT6A	PT7A	PT8A	PT9A	PT10A	PT13A	I/O-D0/DIN
276	PT5D	PT6D	PT7D	PT8D	PT9D	PT12D	I/O
277	PT5C	PT6C	PT7C	PT8C	PT9A	PT12A	I/O
278	PT5B	PT6B	PT7B	PT8B	PT8D	PT11D	I/O
279	PT5A	PT6A	PT7A	PT8A	PT8A	PT11A	I/O-DOUT
280	VDD	VDD	VDD	VDD	VDD	VDD	VDD
281	PT4D	PT5D	PT6D	PT7D	PT7D	PT10D	I/O
282	See Note	PT5C	PT6C	PT7C	PT7C	PT10A	I/O
283	See Note	PT5B	PT6B	PT7B	PT7B	PT9D	I/O
284	PT4C	PT5A	PT6A	PT7A	PT7A	PT9A	I/O
285	PT4B	PT4D	PT5D	PT6D	PT6D	PT8D	I/O
286	See Note	PT4C	PT5C	PT6C	PT6C	PT8A	I/O
287	See Note	PT4B	PT5B	PT6B	PT6B	PT7D	I/O

Note: The ATT2C08 does not have bond pads connected to 304-pin SQFP package pin numbers 17, 18, 19, 21, 57, 59, 64, 89, 91–93, 131, 138, 140, 171, 174, 175, 206–209, 242, 243, 249, 282, 283, 286, and 287.

Pin Information (continued)

Table 23. ATT2C08, ATT2C10, ATT2C12, ATT2C15, ATT2C26, and ATT2C40
304-Pin SQFP/SQFP-PQ2 Pinout (continued)

Pin	2C08 Pad	2C10 Pad	2C12 Pad	2C15 Pad	2C26 Pad	2C40 Pad	Function
288	PT4A	PT4A	PT5A	PT6A	PT6A	PT7A	I/O-TDI
289	PT3D	PT3D	PT4D	PT5D	PT5D	PT6D	I/O
290	PT3C	PT3C	PT4A	PT5A	PT5A	PT6A	I/O
291	PT3B	PT3B	PT3D	PT4D	PT4D	PT5D	I/O
292	PT3A	PT3A	PT3A	PT4A	PT4A	PT5A	I/O-TMS
293	Vss	Vss	Vss	Vss	Vss	Vss	Vss
294	PT2D	PT2D	PT2D	PT3D	PT3D	PT4D	I/O
295	PT2C	PT2C	PT2C	PT3A	PT3A	PT4A	I/O
296	PT2B	PT2B	PT2B	PT2D	PT2D	PT3D	I/O
297	PT2A	PT2A	PT2A	PT2A	PT2A	PT3A	I/O
298	PT1D	PT1D	PT1D	PT1D	PT1D	PT2D	I/O
299	PT1C	PT1C	PT1C	PT1C	PT1C	PT1C	I/O
300	PT1B	PT1B	PT1B	PT1B	PT1B	PT1D	I/O
301	PT1A	PT1A	PT1A	PT1A	PT1A	PT1A	I/O-TCK
302	Vss	Vss	Vss	Vss	Vss	Vss	Vss
303	RD_DATA/ TDO	RD_DATA/ TDO	RD_DATA/TDO	RD_DATA/TDO	RD_DATA/TDO	RD_DATA/TDO	RD_DATA/TDO
304	VDD	VDD	VDD	VDD	VDD	VDD	VDD

Note: The ATT2C08 does not have bond pads connected to 304-pin SQFP package pin numbers 17, 18, 19, 21, 57, 59, 64, 89, 91—93, 131, 138, 140, 171, 174, 175, 206—209, 242, 243, 249, 282, 283, 286, and 287.

Pin Information (continued)

Table 24. ATT2C12 and ATT2C15 364-Pin CPGA Pinout

Pin	2C12 Pad	2C15 Pad	Function	Pin	2C12 Pad	2C15 Pad	Function
G25	Vss	Vss	Vss	A19	PL9D	PL10D	I/O
J27	Vdd	Vdd	Vdd	D18	PL9C	PL10C	I/O
G23	Vss	Vss	Vss	B18	PL9B	PL10B	I/O
E29	PL1D	PL1D	I/O	C17	PL9A	PL10A	I/O-A7
B32	PL1C	PL1C	I/O	G7	Vdd	Vdd	Vdd
D28	PL1B	PL1B	I/O	E17	PL10D	PL11D	I/O
A33	PL1A	PL1A	I/O	A17	PL10C	PL11C	I/O
C29	PL2D	PL2D	I/O-A0	D16	PL10B	PL11B	I/O
E27	See Note	PL2C	I/O	B16	PL10A	PL11A	I/O-A8
B30	See Note	PL2B	I/O	G15	Vss	Vss	Vss
F26	PL2C	PL2A	I/O	A15	PL11D	PL12D	I/O-A9
A31	PL2B	PL3D	I/O	F16	PL11C	PL12C	I/O
D26	See Note	PL3C	I/O	B14	PL11B	PL12B	I/O
C27	See Note	PL3B	I/O	C15	PL11A	PL12A	I/O-A10
E25	PL2A	PL3A	I/O	A13	PL12D	PL13D	I/O
G21	Vss	Vss	Vss	E15	PL12C	PL13C	I/O
B28	PL3D	PL4D	I/O	A11	PL12B	PL13B	I/O
F24	PL3C	PL4C	I/O	D14	PL12A	PL13A	I/O-A11
A29	PL3B	PL4B	I/O	C13	PL13D	PL14D	I/O-A12
D24	PL3A	PL4A	I/O	B12	PL13C	PL14C	I/O
C25	PL4D	PL5D	I/O	F14	PL13B	PL14B	I/O
E23	PL4C	PL5C	I/O	A9	PL13A	PL14A	I/O
B26	PL4B	PL5B	I/O	E13	PL14D	PL15D	I/O
F22	PL4A	PL5A	I/O-A1	B10	PL14C	PL15C	I/O
G19	Vss	Vss	Vss	D12	PL14B	PL15B	I/O-A13
D22	PL5D	PL6D	I/O	C11	PL14A	PL15A	I/O
A27	PL5C	PL6C	I/O	G13	Vss	Vss	Vss
E21	PL5B	PL6B	I/O	F12	PL15D	PL16D	I/O
C23	PL5A	PL6A	I/O-A2	A7	PL15C	PL16C	I/O
F20	PL6D	PL7D	I/O	E11	PL15B	PL16B	I/O
B24	PL6C	PL7C	I/O	B8	PL15A	PL16A	I/O
C21	PL6B	PL7B	I/O	D10	PL16D	PL17D	I/O-A14
A25	PL6A	PL7A	I/O-A3	C9	PL16C	PL17C	I/O
G27	Vdd	Vdd	Vdd	F10	PL16B	PL17B	I/O
B22	PL7D	PL8D	I/O	A5	PL16A	PL17A	I/O
D20	PL7C	PL8C	I/O	G11	Vss	Vss	Vss
A23	PL7B	PL8B	I/O	E9	PL17D	PL18D	I/O
E19	PL7A	PL8A	I/O-A4	B6	PL17C	PL18C	I/O
A21	PL8D	PL9D	I/O-A5	D8	See Note	PL18B	I/O
C19	PL8C	PL9C	I/O	C7	PL17B	PL18A	I/O
B20	PL8B	PL9B	I/O	F8	PL17A	PL19D	I/O
F18	PL8A	PL9A	I/O-A6	A3	PL18D	PL19C	I/O
G17	Vss	Vss	Vss	E7	See Note	PL19B	I/O

Notes: The ATT2C12 does not have bond pads connected to 364-pin CPGA package pin numbers E27, B30, D26, C27, D8, E7, D6, C3, B2, G5, D2, H4, AF4, AL1, AG5, AL3, AK6, AM4, AH8, AJ9, AN31, AK26, AH26, AL29, AH30, AG29, AK32, AG31, F32, H30, C33, and G29. The J9 pin is used for package orientation only. The ceramic PGA contains single large Vdd and Vss planes to which all Vdd and Vss bond pads are connected.

Pin Information (continued)

Table 24. ATT2C12 and ATT2C15 364-Pin CPGA Pinout (continued)

Pin	2C12 Pad	2C15 Pad	Function	Pin	2C12 Pad	2C15 Pad	Function
B4	PL18C	PL19A	I/O	L1	PB7C	PB8C	I/O
C5	PL18B	PL20D	I/O	R5	PB7D	PB8D	I/O
D6	See Note	PL20C	I/O	N1	PB8A	PB9A	I/O
C3	See Note	PL20B	I/O	R3	PB8B	PB9B	I/O
F6	PL18A	PL20A	I/O-A15	P2	PB8C	PB9C	I/O
G9	Vss	Vss	Vss	T6	PB8D	PB9D	I/O
D4	CCLK	CCLK	CCLK	R1	PB9A	PB10A	I/O
J7	Vdd	Vdd	Vdd	T4	PB9B	PB10B	I/O
L7	Vdd	Vdd	Vdd	T2	PB9C	PB10C	I/O
R7	Vss	Vss	Vss	U3	PB9D	PB10D	I/O
E5	PB1A	PB1A	I/O-A16	U7	Vss	Vss	Vss
B2	See Note	PB1B	I/O	U5	PB10A	PB11A	I/O
F4	PB1B	PB1C	I/O	U1	PB10B	PB11B	I/O
A1	PB1C	PB1D	I/O	V4	PB10C	PB11C	I/O
E3	PB1D	PB2A	I/O	V2	PB10D	PB11D	I/O
G5	See Note	PB2B	I/O	W1	PB11A	PB12A	I/O
D2	See Note	PB2C	I/O	V6	PB11B	PB12B	I/O
H6	PB2A	PB2D	I/O	Y2	PB11C	PB12C	I/O
C1	PB2B	PB3A	I/O	W3	PB11D	PB12D	I/O
H4	See Note	PB3B	I/O	AA1	PB12A	PB13A	I/O-HDC
G3	PB2C	PB3C	I/O	W5	PB12B	PB13B	I/O
J5	PB2D	PB3D	I/O	AC1	PB12C	PB13C	I/O
F2	PB3A	PB4A	I/O	Y4	PB12D	PB13D	I/O
K6	PB3B	PB4B	I/O	AA7	Vdd	Vdd	Vdd
E1	PB3C	PB4C	I/O	AA3	PB13A	PB14A	I/O-LDC
K4	PB3D	PB4D	I/O-A17	AB2	PB13B	PB14B	I/O
J3	PB4A	PB5A	I/O	Y6	PB13C	PB14C	I/O
L5	PB4B	PB5B	I/O	AE1	PB13D	PB14D	I/O
H2	PB4C	PB5C	I/O	AA5	PB14A	PB15A	I/O
M6	PB4D	PB5D	I/O	AD2	PB14B	PB15B	I/O
M4	PB5A	PB6A	I/O	AB4	PB14C	PB15C	I/O
G1	PB5B	PB6B	I/O	AC3	PB14D	PB15D	I/O
N5	PB5C	PB6C	I/O	AB6	PB15A	PB16A	I/O-INIT
L3	PB5D	PB6D	I/O	AG1	PB15B	PB16B	I/O
P6	PB6A	PB7A	I/O	AC5	PB15C	PB16C	I/O
K2	PB6B	PB7B	I/O	AF2	PB15D	PB16D	I/O
N3	PB6C	PB7C	I/O	AD4	PB16A	PB17A	I/O
J1	PB6D	PB7D	I/O	AE3	PB16B	PB17B	I/O
N7	Vdd	Vdd	Vdd	AD6	PB16C	PB17C	I/O
M2	PB7A	PB8A	I/O	AJ1	PB16D	PB17D	I/O
P4	PB7B	PB8B	I/O	AE5	PB17A	PB18A	I/O

Notes: The ATT2C12 does not have bond pads connected to 364-pin CPGA package pin numbers E27, B30, D26, C27, D8, E7, D6, C3, B2, G5, D2, H4, AF4, AL1, AG5, AL3, AK6, AM4, AH8, AJ9, AN31, AK26, AH26, AL29, AH30, AG29, AK32, AG31, F32, H30, C33, and G29. The J9 pin is used for package orientation only. The ceramic PGA contains single large Vdd and Vss planes to which all Vdd and Vss bond pads are connected.

Pin Information (continued)

Table 24. ATT2C12 and ATT2C15 364-Pin CPGA Pinout (continued)

Pin	2C12 Pad	2C15 Pad	Function	Pin	2C12 Pad	2C15 Pad	Function
AH2	PB17B	PB18B	I/O	AM12	PR13C	PR14C	I/O
AF4	See Note	PB18C	I/O	AL13	PR13D	PR14D	I/O
AG3	PB17C	PB18D	I/O	AE7	VDD	VDD	VDD
AF6	PB17D	PB19A	I/O	AK14	PR12A	PR13A	I/O-M2
AL1	See Note	PB19B	I/O	AN11	PR12B	PR13B	I/O
AG5	See Note	PB19C	I/O	AJ15	PR12C	PR13C	I/O
AK2	PB18A	PB19D	I/O	AN13	PR12D	PR13D	I/O
AJ3	PB18B	PB20A	I/O	AL15	PR11A	PR12A	I/O-M3
AH4	PB18C	PB20B	I/O	AM14	PR11B	PR12B	I/O
AL3	See Note	PB20C	I/O	AH16	PR11C	PR12C	I/O
AH6	PB18D	PB20D	I/O	AN15	PR11D	PR12D	I/O
W7	VSS	VSS	VSS	AG15	VSS	VSS	VSS
AK4	DONE	DONE	DONE	AK16	PR10A	PR11A	I/O
AC7	VDD	VDD	VDD	AM16	PR10B	PR11B	I/O
AG11	VSS	VSS	VSS	AJ17	PR10C	PR11C	I/O
AM2	RESET	RESET	RESET	AN17	PR10D	PR11D	I/O
AJ5	PRGM	PRGM	PRGM	AG7	VDD	VDD	VDD
AN1	PR18A	PR20A	I/O-M0	AL17	PR9A	PR10A	I/O
AK6	See Note	PR20B	I/O	AK18	PR9B	PR10B	I/O
AL5	PR18B	PR20C	I/O	AM18	PR9C	PR10C	I/O
AJ7	PR18C	PR20D	I/O	AN19	PR9D	PR10D	I/O
AG9	PR18D	PR19A	I/O	AG17	VSS	VSS	VSS
AM4	See Note	PR19B	I/O	AH18	PR8A	PR9A	I/O
AH8	See Note	PR19C	I/O	AM20	PR8B	PR9B	I/O
AN3	PR17A	PR19D	I/O	AL19	PR8C	PR9C	I/O
AK8	PR17B	PR18A	I/O	AN21	PR8D	PR9D	I/O
AL7	PR17C	PR18B	I/O	AJ19	PR7A	PR8A	I/O-CS1
AJ9	See Note	PR18C	I/O	AN23	PR7B	PR8B	I/O
AM6	PR17D	PR18D	I/O	AK20	PR7C	PR8C	I/O
AG13	VSS	VSS	VSS	AM22	PR7D	PR8D	I/O
AH10	PR16A	PR17A	I/O	AG27	VDD	VDD	VDD
AN5	PR16B	PR17B	I/O	AN25	PR6A	PR7A	I/O-CS0
AK10	PR16C	PR17C	I/O	AL21	PR6B	PR7B	I/O
AL9	PR16D	PR17D	I/O	AM24	PR6C	PR7C	I/O
AJ11	PR15A	PR16A	I/O	AH20	PR6D	PR7D	I/O
AM8	PR15B	PR16B	I/O	AL23	PR5A	PR6A	I/O
AH12	PR15C	PR16C	I/O	AJ21	PR5B	PR6B	I/O
AN7	PR15D	PR16D	I/O-M1	AN27	PR5C	PR6C	I/O
AL11	PR14A	PR15A	I/O	AK22	PR5D	PR6D	I/O
AK12	PR14B	PR15B	I/O	AG19	VSS	VSS	VSS
AM10	PR14C	PR15C	I/O	AM26	PR4A	PR5A	I/O-RD
AJ13	PR14D	PR15D	I/O	AH22	PR4B	PR5B	I/O
AN9	PR13A	PR14A	I/O	AL25	PR4C	PR5C	I/O
AH14	PR13B	PR14B	I/O	AJ23	PR4D	PR5D	I/O

Notes: The ATT2C12 does not have bond pads connected to 364-pin CPGA package pin numbers E27, B30, D26, C27, D8, E7, D6, C3, B2, G5, D2, H4, AF4, AL1, AG5, AL3, AK6, AM4, AH8, AJ9, AN31, AK26, AH26, AL29, AH30, AG29, AK32, AG31, F32, H30, C33, and G29. The J9 pin is used for package orientation only. The ceramic PGA contains single large VDD and VSS planes to which all VDD and VSS bond pads are connected.

Pin Information (continued)

Table 24. ATT2C12 and ATT2C15 364-Pin CPGA Pinout (continued)

Pin	2C12 Pad	2C15 Pad	Function	Pin	2C12 Pad	2C15 Pad	Function
AN29	PR3A	PR4A	I/O	AA29	PT14B	PT15B	I/O
AK24	PR3B	PR4B	I/O	AC31	PT14A	PT15A	I/O
AM28	PR3C	PR4C	I/O	Y28	PT13D	PT14D	I/O
AH24	PR3D	PR4D	I/O	AD32	PT13C	PT14C	I/O
AG21	Vss	Vss	Vss	AA31	PT13B	PT14B	I/O-D6
AL27	PR2A	PR3A	I/O-WR	AE33	PT13A	PT14A	I/O
AJ25	PR2B	PR3B	I/O	AA27	Vdd	Vdd	Vdd
AN31	See Note	PR3C	I/O	AB32	PT12D	PT13D	I/O
AK26	See Note	PR3D	I/O	Y30	PT12C	PT13C	I/O
AM30	PR2C	PR2A	I/O	AC33	PT12B	PT13B	I/O
AH26	See Note	PR2B	I/O	W29	PT12A	PT13A	I/O-D5
AL29	See Note	PR2C	I/O	AA33	PT11D	PT12D	I/O
AG25	PR2D	PR2D	I/O	W31	PT11C	PT12C	I/O
AJ27	PR1A	PR1A	I/O	Y32	PT11B	PT12B	I/O
AL31	PR1B	PR1B	I/O	V28	PT11A	PT12A	I/O-D4
AK28	PR1C	PR1C	I/O	W33	PT10D	PT11D	I/O
AK30	PR1D	PR1D	I/O	V30	PT10C	PT11C	I/O
AG23	Vss	Vss	Vss	V32	PT10B	PT11B	I/O
AH28	RD_CFGN	RD_CFGN	RD_CFGN	U31	PT10A	PT11A	I/O-D3
AE27	Vdd	Vdd	Vdd	U27	Vss	Vss	Vss
AC27	Vdd	Vdd	Vdd	U29	PT9D	PT10D	I/O
W27	Vss	Vss	Vss	U33	PT9C	PT10C	I/O
AJ29	PT18D	PT20D	I/O	T30	PT9B	PT10B	I/O
AM32	PT18C	PT20C	I/O	T32	PT9A	PT10A	I/O-D2
AH30	See Note	PT20B	I/O	R33	PT8D	PT9D	I/O-D1
AN33	PT18B	PT20A	I/O	T28	PT8C	PT9C	I/O
AJ31	PT18A	PT19D	I/O	P32	PT8B	PT9B	I/O
AG29	See Note	PT19C	I/O	R31	PT8A	PT9A	I/O-D0/DIN
AK32	See Note	PT19B	I/O	N33	PT7D	PT8D	I/O
AF28	PT17D	PT19A	I/O-RDY/RCLK	R29	PT7C	PT8C	I/O
AL33	PT17C	PT18D	I/O	L33	PT7B	PT8B	I/O
AF30	PT17B	PT18C	I/O	P30	PT7A	PT8A	I/O-DOUT
AG31	See Note	PT18B	I/O	N27	Vdd	Vdd	Vdd
AE29	PT17A	PT18A	I/O	N31	PT6D	PT7D	I/O
AH32	PT16D	PT17D	I/O	M32	PT6C	PT7C	I/O
AD28	PT16C	PT17C	I/O	P28	PT6B	PT7B	I/O
AJ33	PT16B	PT17B	I/O	J33	PT6A	PT7A	I/O
AD30	PT16A	PT17A	I/O	N29	PT5D	PT6D	I/O
AE31	PT15D	PT16D	I/O-D7	K32	PT5C	PT6C	I/O
AC29	PT15C	PT16C	I/O	M30	PT5B	PT6B	I/O
AF32	PT15B	PT16B	I/O	L31	PT5A	PT6A	I/O-TDI
AB28	PT15A	PT16A	I/O	M28	PT4D	PT5D	I/O
AB30	PT14D	PT15D	I/O	G33	PT4C	PT5C	I/O

Notes: The ATT2C12 does not have bond pads connected to 364-pin CPGA package pin numbers E27, B30, D26, C27, D8, E7, D6, C3, B2, G5, D2, H4, AF4, AL1, AG5, AL3, AK6, AM4, AH8, AJ9, AN31, AK26, AH26, AL29, AH30, AG29, AK32, AG31, F32, H30, C33, and G29. The J9 pin is used for package orientation only. The ceramic PGA contains single large Vdd and Vss planes to which all Vdd and Vss bond pads are connected.

Pin Information (continued)

Table 24. ATT2C12 and ATT2C15 364-Pin CPGA Pinout (continued)

Pin	2C12 Pad	2C15 Pad	Function	Pin	2C12 Pad	2C15 Pad	Function
AG33	PT14C	PT15C	I/O	L29	PT4B	PT5B	I/O
H32	PT4A	PT5A	I/O	C33	See Note	PT2C	I/O
K30	PT3D	PT4D	I/O	G29	See Note	PT2B	I/O
J31	PT3C	PT4C	I/O	D32	PT2A	PT2A	I/O
K28	PT3B	PT4B	I/O	E31	PT1D	PT1D	I/O
E33	PT3A	PT4A	I/O-TMS	F30	PT1C	PT1C	I/O
J29	PT2D	PT3D	I/O	C31	PT1B	PT1B	I/O
F32	See Note	PT3C	I/O	F28	PT1A	PT1A	I/O-TCK
H30	See Note	PT3B	I/O	R27	Vss	Vss	Vss
G31	PT2C	PT3A	I/O	D30	RD_DATA/TDO	RD_DATA/TDO	RD_DATA/TDO
H28	PT2B	PT2D	I/O	L27	VDD	VDD	VDD

Notes: The ATT2C12 does not have bond pads connected to 364-pin CPGA package pin numbers E27, B30, D26, C27, D8, E7, D6, C3, B2, G5, D2, H4, AF4, AL1, AG5, AL3, AK6, AM4, AH8, AJ9, AN31, AK26, AH26, AL29, AH30, AG29, AK32, AG31, F32, H30, C33, and G29. The J9 pin is used for package orientation only. The ceramic PGA contains single large VDD and VSS planes to which all VDD and VSS bond pads are connected.

Pin Information (continued)

Table 25. ATT2C26 and ATT2C40 428-Pin CPGA Pinout

Pin	2C26 Pad	2C40 Pad	Function	Pin	2C26 Pad	2C40 Pad	Function
D34	Vss	Vss	Vss	B22	PL10B	PL13B	I/O
AL33	Vdd	Vdd	Vdd	F20	PL10A	PL13A	I/O
E33	Vss	Vss	Vss	C21	PL11D	PL14D	I/O
C33	PL1D	PL1D	I/O	D20	PL11C	PL14C	I/O
D32	PL1C	PL1A	I/O	A21	PL11B	PL14B	I/O
B32	PL1B	PL2D	I/O	G19	PL11A	PL14A	I/O-A6
E29	PL1A	PL2A	I/O	F32	Vss	Vss	Vss
F28	PL2D	PL3D	I/O-A0	B20	PL12D	PL15D	I/O
C31	PL2C	PL3C	I/O	F18	PL12C	PL15C	I/O
G27	PL2B	PL3B	I/O	C19	PL12B	PL15B	I/O
A31	PL2A	PL3A	I/O	E19	PL12A	PL15A	I/O-A7
H26	PL3D	PL4D	I/O	H18	Vdd	Vdd	Vdd
D30	PL3C	PL4C	I/O	E17	PL13D	PL16D	I/O
D28	PL3B	PL4B	I/O	A19	PL13C	PL16C	I/O
B30	PL3A	PL4A	I/O	D18	PL13B	PL16B	I/O
F26	PL4D	PL5D	I/O	B18	PL13A	PL16A	I/O-A8
C29	PL4C	PL5C	I/O	G31	Vss	Vss	Vss
G25	PL4B	PL5B	I/O	D14	PL14D	PL17D	I/O-A9
A29	PL4A	PL6D	I/O	A17	PL14C	PL17C	I/O
E27	PL5D	PL7D	I/O	G17	PL14B	PL17B	I/O
B28	PL5C	PL7C	I/O	C17	PL14A	PL17A	I/O
H24	PL5B	PL7B	I/O	F16	PL15D	PL18D	I/O
C27	PL5A	PL8D	I/O-A1	B16	PL15C	PL18C	I/O
E25	PL6D	PL9D	I/O	E15	PL15B	PL18B	I/O
A27	PL6C	PL9C	I/O	D16	PL15A	PL18A	I/O-A10
G23	PL6B	PL9B	I/O	E13	PL16D	PL19D	I/O
D26	PL6A	PL9A	I/O-A2	A15	PL16C	PL19C	I/O
F24	PL7D	PL10D	I/O	F14	PL16B	PL19B	I/O
B26	PL7C	PL10C	I/O	C15	PL16A	PL19A	I/O
D24	PL7B	PL10B	I/O	H16	PL17D	PL20D	I/O
C25	PL7A	PL10A	I/O-A3	B14	PL17C	PL20C	I/O
H22	Vdd	Vdd	Vdd	G15	PL17B	PL20B	I/O
A25	PL8D	PL11D	I/O	A13	PL17A	PL20A	I/O-A11
E23	PL8C	PL11C	I/O	H14	Vdd	Vdd	Vdd
B24	PL8B	PL11B	I/O	C13	PL18D	PL21D	I/O-A12
F22	PL8A	PL11A	I/O	D10	PL18C	PL21C	I/O
C23	PL9D	PL12D	I/O	B12	PL18B	PL21B	I/O
G21	PL9C	PL12C	I/O	E11	PL18A	PL21A	I/O
A23	PL9B	PL12B	I/O	D12	PL19D	PL22D	I/O
H20	PL9A	PL12A	I/O-A4	F12	PL19C	PL22C	I/O
D22	PL10D	PL13D	I/O-A5	A11	PL19B	PL22B	I/O-A13
E21	PL10C	PL13C	I/O	G13	PL19A	PL22A	I/O

Note: The ceramic PGA contains single large Vdd and Vss planes to which all Vdd and Vss bond pads are connected.

Pin Information (continued)

Table 25. ATT2C26 and ATT2C40 428-Pin CPGA Pinout (continued)

Pin	2C26 Pad	2C40 Pad	Function	Pin	2C26 Pad	2C40 Pad	Function
C11	PL20D	PL23D	I/O	L3	PB5C	PB6C	I/O
E9	PL20C	PL23C	I/O	M6	PB5D	PB6D	I/O
B10	PL20B	PL24D	I/O	L1	PB6A	PB7A	I/O
H12	PL20A	PL25D	I/O	N7	PB6B	PB7D	I/O
A9	PL21D	PL25A	I/O-A14	M4	PB6C	PB8A	I/O
F10	PL21C	PL26C	I/O	N5	PB6D	PB8D	I/O
C9	PL21B	PL26B	I/O	M2	PB7A	PB9A	I/O
G11	PL21A	PL26A	I/O	P6	PB7B	PB9D	I/O
B8	PL22D	PL27D	I/O	N3	PB7C	PB10A	I/O
E7	PL22C	PL27C	I/O	P4	PB7D	PB10D	I/O
D8	PL22B	PL27B	I/O	P8	VDD	VDD	VDD
F8	PL22A	PL27A	I/O	R7	PB8A	PB11A	I/O
A7	PL23D	PL28D	I/O	N1	PB8B	PB11B	I/O
G9	PL23C	PL28C	I/O	T8	PB8C	PB11C	I/O
C7	PL23B	PL28B	I/O	P2	PB8D	PB11D	I/O
H10	PL23A	PL28A	I/O	R5	PB9A	PB12A	I/O
D6	PL24D	PL29A	I/O	R3	PB9B	PB12B	I/O
B6	PL24C	PL30C	I/O	T6	PB9C	PB12C	I/O
F4	PL24B	PL30B	I/O	R1	PB9D	PB12D	I/O
C5	PL24A	PL30A	I/O-A15	T4	PB10A	PB13A	I/O
H30	VSS	VSS	VSS	U7	PB10B	PB13B	I/O
G5	CCLK	CCLK	CCLK	T2	PB10C	PB13C	I/O
AM34	VDD	VDD	VDD	U5	PB10D	PB13D	I/O
AN35	VDD	VDD	VDD	U3	PB11A	PB14A	I/O
D4	VSS	VSS	VSS	V4	PB11B	PB14B	I/O
H6	PB1A	PB1A	I/O-A16	U1	PB11C	PB14C	I/O
E3	PB1B	PB1B	I/O	V6	PB11D	PB14D	I/O
J7	PB1C	PB2A	I/O	E5	VSS	VSS	VSS
F2	PB1D	PB2D	I/O	V2	PB12A	PB15A	I/O
G3	PB2A	PB3A	I/O	W5	PB12B	PB15B	I/O
J5	PB2B	PB3B	I/O	W3	PB12C	PB15C	I/O
G1	PB2C	PB3C	I/O	W7	PB12D	PB15D	I/O
K8	PB2D	PB3D	I/O	F6	VSS	VSS	VSS
H4	PB3A	PB4A	I/O	W1	PB13A	PB16A	I/O
K6	PB3B	PB4B	I/O	Y4	PB13B	PB16B	I/O
H2	PB3C	PB4C	I/O	Y2	PB13C	PB16C	I/O
K4	PB3D	PB4D	I/O	Y6	PB13D	PB16D	I/O
J3	PB4A	PB5A	I/O	G7	VSS	VSS	VSS
L7	PB4B	PB5B	I/O	AA1	PB14A	PB17A	I/O
J1	PB4C	PB5C	I/O	Y8	PB14B	PB17B	I/O
M8	PB4D	PB5D	I/O-A17	AA3	PB14C	PB17C	I/O
K2	PB5A	PB6A	I/O	AA5	PB14D	PB17D	I/O
L5	PB5B	PB6B	I/O	AB2	PB15A	PB18A	I/O

Note: The ceramic PGA contains single large VDD and VSS planes to which all VDD and VSS bond pads are connected.

Pin Information (continued)

Table 25. ATT2C26 and ATT2C40 428-Pin CPGA Pinout (continued)

Pin	2C26 Pad	2C40 Pad	Function	Pin	2C26 Pad	2C40 Pad	Function
AA7	PB15B	PB18B	I/O	AR5	RESET	RESET	RESET
AB4	PB15C	PB18C	I/O	AP6	PRGM	PRGM	PRGM
AB6	PB15D	PB18D	I/O	AT6	PR24A	PR30A	I/O-M0
AC5	PB16A	PB19A	I/O-HDC	AN7	PR24B	PR30B	I/O
AC1	PB16B	PB19B	I/O	AR7	PR24C	PR29A	I/O
AD4	PB16C	PB19C	I/O	AM8	PR24D	PR29D	I/O
AC3	PB16D	PB19D	I/O	AK32	VDD	VDD	VDD
AD6	PB17A	PB20A	I/O	AK10	PR23A	PR28A	I/O
AD2	PB17B	PB20B	I/O	AU7	PR23B	PR28B	I/O
AC7	PB17C	PB20C	I/O	AL9	PR23C	PR28C	I/O
AE1	PB17D	PB20D	I/O	AP8	PR23D	PR28D	I/O
V8	VDD	VDD	VDD	AN9	PR22A	PR27A	I/O
AE3	PB18A	PB21A	I/O-LDC	AT8	PR22B	PR27B	I/O
AE5	PB18B	PB21D	I/O	AL11	PR22C	PR27C	I/O
AF2	PB18C	PB22A	I/O	AR9	PR22D	PR27D	I/O
AG5	PB18D	PB22D	I/O	AP4	VSS	VSS	VSS
AF4	PB19A	PB23A	I/O	AK12	PR21A	PR26A	I/O
AF6	PB19B	PB24A	I/O	AU9	PR21B	PR26B	I/O
AG1	PB19C	PB24C	I/O	AM10	PR21C	PR26C	I/O
AD8	PB19D	PB24D	I/O	AT10	PR21D	PR25A	I/O
AG3	PB20A	PB25A	I/O-INIT	AP10	PR20A	PR24A	I/O
AE7	PB20B	PB25B	I/O	AR11	PR20B	PR24B	I/O
AH2	PB20C	PB25C	I/O	AL13	PR20C	PR24D	I/O
AH4	PB20D	PB25D	I/O	AU11	PR20D	PR23D	I/O-M1
AJ1	PB21A	PB26A	I/O	AK14	PR19A	PR22A	I/O
AH6	PB21B	PB26B	I/O	AP12	PR19B	PR22B	I/O
AJ3	PB21C	PB26C	I/O	AM12	PR19C	PR22C	I/O
AF8	PB21D	PB26D	I/O	AT12	PR19D	PR22D	I/O
AK2	PB22A	PB27A	I/O	AN11	PR18A	PR21A	I/O
AG7	PB22B	PB27B	I/O	AR13	PR18B	PR21B	I/O
AK4	PB22C	PB27C	I/O	AN13	PR18C	PR21C	I/O
AJ5	PB22D	PB27D	I/O	AU13	PR18D	PR21D	I/O
AL1	PB23A	PB28A	I/O	AK16	VDD	VDD	VDD
AJ7	PB23B	PB28B	I/O	AT14	PR17A	PR20A	I/O-M2
AL3	PB23C	PB28C	I/O	AL15	PR17B	PR20B	I/O
AH8	PB23D	PB28D	I/O	AR15	PR17C	PR20C	I/O
AK6	PB24A	PB29A	I/O	AM14	PR17D	PR20D	I/O
AM2	PB24B	PB29D	I/O	AU15	PR16A	PR19A	I/O
AL5	PB24C	PB30C	I/O	AP14	PR16B	PR19B	I/O
AN3	PB24D	PB30D	I/O	AP16	PR16C	PR19C	I/O
H8	VSS	VSS	VSS	AN15	PR16D	PR19D	I/O
AM4	DONE	DONE	DONE	AT16	PR15A	PR18A	I/O-M3
AB8	VDD	VDD	VDD	AM16	PR15B	PR18B	I/O

Note: The ceramic PGA contains single large VDD and VSS planes to which all VDD and VSS bond pads are connected.

Pin Information (continued)

Table 25. ATT2C26 and ATT2C40 428-Pin CPGA Pinout (continued)

Pin	2C26 Pad	2C40 Pad	Function	Pin	2C26 Pad	2C40 Pad	Function
AR17	PR15C	PR18C	I/O	AR27	PR5A	PR8A	I/O-RD
AL17	PR15D	PR18D	I/O	AL25	PR5B	PR7A	I/O
AU17	PR14A	PR17A	I/O	AT28	PR5C	PR7C	I/O
AN17	PR14B	PR17B	I/O	AP28	PR5D	PR6A	I/O
AT18	PR14C	PR17C	I/O	AU29	PR4A	PR5A	I/O
AK18	PR14D	PR17D	I/O	AM28	PR4B	PR5B	I/O
AN5	Vss	Vss	Vss	AR29	PR4C	PR5C	I/O
AR19	PR13A	PR16A	I/O	AK26	PR4D	PR5D	I/O
AM18	PR13B	PR16B	I/O	AL7	Vss	Vss	Vss
AN19	PR13C	PR16C	I/O	AT30	PR3A	PR4A	I/O-WR
AP18	PR13D	PR16D	I/O	AL27	PR3B	PR4B	I/O
AK20	Vdd	Vdd	Vdd	AP30	PR3C	PR4C	I/O
AL19	PR12A	PR15A	I/O	AN29	PR3D	PR4D	I/O
AU19	PR12B	PR15B	I/O	AU31	PR2A	PR3A	I/O
AP20	PR12C	PR15C	I/O	AL29	PR2B	PR3B	I/O
AT20	PR12D	PR15D	I/O	AR31	PR2C	PR3C	I/O
AM6	Vss	Vss	Vss	AK28	PR2D	PR3D	I/O
AM20	PR11A	PR14A	I/O	AM30	PR1A	PR2A	I/O
AU21	PR11B	PR14B	I/O	AT32	PR1B	PR2D	I/O
AN21	PR11C	PR14C	I/O	AN31	PR1C	PR1A	I/O
AR21	PR11D	PR14D	I/O	AR33	PR1D	PR1D	I/O
AL21	PR10A	PR13A	I/O	AK8	Vss	Vss	Vss
AT22	PR10B	PR13B	I/O	AP32	RD_CFGN	RD_CFGN	RD_CFGN
AM22	PR10C	PR13C	I/O	AJ31	Vdd	Vdd	Vdd
AP22	PR10D	PR13D	I/O	AH30	Vdd	Vdd	Vdd
AN23	PR9A	PR12A	I/O-CS1	AP34	Vss	Vss	Vss
AU23	PR9B	PR12B	I/O	AJ33	PT24D	PT30D	I/O
AP24	PR9C	PR12C	I/O	AM36	PT24C	PT30A	I/O
AR23	PR9D	PR12D	I/O	AH32	PT24B	PT29B	I/O
AK22	PR8A	PR11A	I/O	AL35	PT24A	PT29A	I/O
AT24	PR8B	PR11B	I/O	AL37	PT23D	PT28D	I/O
AL23	PR8C	PR11C	I/O	AH34	PT23C	PT28C	I/O
AU25	PR8D	PR11D	I/O	AK34	PT23B	PT28B	I/O
AK24	Vdd	Vdd	Vdd	AG31	PT23A	PT28A	I/O-RDY/RCLK
AR25	PR7A	PR10A	I/O-CS0	AK36	PT22D	PT27D	I/O
AM24	PR7B	PR10B	I/O	AF30	PT22C	PT27C	I/O
AT26	PR7C	PR10C	I/O	AJ35	PT22B	PT27B	I/O
AN25	PR7D	PR10D	I/O	AG33	PT22A	PT27A	I/O
AP26	PR6A	PR9A	I/O	AJ37	PT21D	PT26D	I/O
AN27	PR6B	PR9B	I/O	AF32	PT21C	PT26C	I/O
AU27	PR6C	PR9C	I/O	AH36	PT21B	PT26B	I/O
AM26	PR6D	PR9D	I/O	AE31	PT21A	PT26A	I/O

Note: The ceramic PGA contains single large Vdd and Vss planes to which all Vdd and Vss bond pads are connected.

Pin Information (continued)

Table 25. ATT2C26 and ATT2C40 428-Pin CPGA Pinout (continued)

Pin	2C26 Pad	2C40 Pad	Function	Pin	2C26 Pad	2C40 Pad	Function
AG35	PT20D	PT25D	I/O-D7	T32	PT10C	PT13C	I/O
AE33	PT20C	PT25C	I/O	T34	PT10B	PT13B	I/O
AG37	PT20B	PT25B	I/O	N33	PT10A	PT13A	I/O-D0/DIN
AD32	PT20A	PT25A	I/O	P32	PT9D	PT12D	I/O
AF34	PT19D	PT24D	I/O	R35	PT9C	PT12C	I/O
AD34	PT19C	PT24C	I/O	R31	PT9B	PT12B	I/O
AF36	PT19B	PT24B	I/O	P36	PT9A	PT12A	I/O
AC33	PT19A	PT23D	I/O	M32	PT8D	PT11D	I/O
AE35	PT18D	PT22D	I/O	N37	PT8C	PT11C	I/O
AC31	PT18C	PT22A	I/O	N31	PT8B	PT11B	I/O
AE37	PT18B	PT21D	I/O-D6	M36	PT8A	PT11A	I/O-DOUT
AB32	PT18A	PT21A	I/O	Y30	VDD	VDD	VDD
AD30	VDD	VDD	VDD	N35	PT7D	PT10D	I/O
AB30	PT17D	PT20D	I/O	P30	PT7C	PT10A	I/O
AD36	PT17C	PT20C	I/O	L37	PT7B	PT9D	I/O
Y34	PT17B	PT20B	I/O	L33	PT7A	PT9A	I/O
AC35	PT17A	PT20A	I/O	M34	PT6D	PT8D	I/O
AA33	PT16D	PT19D	I/O	K34	PT6C	PT8A	I/O
AC37	PT16C	PT19C	I/O	L35	PT6B	PT7D	I/O
AA31	PT16B	PT19B	I/O	M30	PT6A	PT7A	I/O-TDI
AB34	PT16A	PT19A	I/O-D5	J37	PT5D	PT6D	I/O
AB36	PT15D	PT18D	I/O	L31	PT5C	PT6C	I/O
V34	PT15C	PT18C	I/O	K36	PT5B	PT6B	I/O
AA35	PT15B	PT18B	I/O	K32	PT5A	PT6A	I/O
Y32	PT15A	PT18A	I/O	H36	PT4D	PT5D	I/O
AA37	PT14D	PT17D	I/O	J33	PT4C	PT5C	I/O
W33	PT14C	PT17C	I/O	J35	PT4B	PT5B	I/O
Y36	PT14B	PT17B	I/O	J31	PT4A	PT5A	I/O-TMS
U33	PT14A	PT17A	I/O-D4	AL31	VSS	VSS	VSS
W35	PT13D	PT16D	I/O	G37	PT3D	PT4D	I/O
W31	PT13C	PT16C	I/O	K30	PT3C	PT4C	I/O
W37	PT13B	PT16B	I/O	H34	PT3B	PT4B	I/O
V32	PT13A	PT16A	I/O-D3	H32	PT3A	PT4A	I/O
AN33	VSS	VSS	VSS	G35	PT2D	PT3D	I/O
V36	PT12D	PT15D	I/O	G33	PT2C	PT3C	I/O
P34	PT12C	PT15C	I/O	F36	PT2B	PT3B	I/O
U37	PT12B	PT15B	I/O	E31	PT2A	PT3A	I/O
V30	PT12A	PT15A	I/O-D2	F30	PT1D	PT2D	I/O
AM32	VSS	VSS	VSS	F34	PT1C	PT2A	I/O
T36	PT11D	PT14D	I/O-D1	G29	PT1B	PT1D	I/O
R33	PT11C	PT14C	I/O	E35	PT1A	PT1A	I/O-TCK
U35	PT11B	PT14B	I/O	AK30	VSS	VSS	VSS
U31	PT11A	PT14A	I/O	H28	RD DATA/TDO	RD DATA/TDO	RD_DATA/TDO
R37	PT10D	PT13D	I/O	T30	VDD	VDD	VDD

Note: The ceramic PGA contains single large VDD and VSS planes to which all VDD and VSS bond pads are connected.

2

Package Thermal Characteristics

When silicon die junction temperature is below the recommended junction temperature of 125 °C, the temperature-activated failure mechanisms are minimized. There are four major factors that affect the thermal resistance value: silicon device size/paddle size, board mounting configuration (board density, multilayer nature of board), package type and size, and system airflow over the package. The values in the table below reflect the capability of the various package types to dissipate heat at given airflow rates. The numbers represent the delta °C/W between the ambient temperature and the device junction temperature.

To test package thermal characteristics, a single package containing a 0.269 in. sq. test IC of each configuration is mounted at the center of a printed-circuit board (PCB) measuring 8 in. x 13 in. x 0.062 in. The assembled PCB is mounted vertically in the center of the rectangular test section of a wind tunnel. The walls of the wind tunnel simulate adjacent boards in the electronic rack and can be adjusted to study the effects of PCB spacing. Forced air at room temperature is supplied by a pair of push-pull blowers which can be regulated to supply the desired air velocities. The air velocity is measured with a hot-wire anemometer at the center of the channel, 3 in. upstream from the package.

A typical test consists of regulating the wind tunnel blowers to obtain the desired air velocity and applying power to the test IC. The power to the IC is adjusted until the maximum junction temperature (as measured by its diodes) reaches 115 °C to 120 °C. The thermal resistance Θ_{JA} (°C/W) is computed by using the power supplied to the IC, junction temperature, ambient temperature, and air velocity:

$$\Theta_{JA} = \frac{T_J - T_A}{Q_C}$$

where:

T_J = peak temperature on the active surface of the IC

T_A = ambient air temperature

Q_C = IC power

The tests are repeated at several velocities from 0 fpm (feet per minute) to 1000 fpm.

The definition of the junction-to-case thermal resistance Θ_{JC} is:

$$\Theta_{JC} = \frac{T_J - T_C}{Q_C}$$

where:

T_C = temperature measured to the thermocouple at the top dead center of the package

The actual Θ_{JC} measurement performed at Lucent, Θ_{J-TDC} , uses a different package mounting arrangement than the one defined for Θ_{JC} in MIL-STD-883D and SEMI standards. Please contact Lucent for a diagram.

The maximum power dissipation for a package is calculated from the maximum allowed junction temperature (T_{Jmax} , 125 °C), the maximum ambient temperature (T_{Amax}), and the junction-to-ambient thermal characteristic for the given package (Θ_{JA}). The maximum power for the package is calculated as follows:

$$\text{Max. Power (Watts)} = (125\text{ °C} - T_{Amax}) \times (1/\Theta_{JA})$$

In Table 26 and Table 26, a maximum power dissipation for each package is shown with $T_{Amax} = 70\text{ °C}$ for the commercial temperature range and the Θ_{JA} used is for 0 feet per minute of air flowing over the package. If your application does not correspond to these parameters, the maximum power dissipation should be recalculated using the formula above.

Once the power dissipated by the FPGA has been determined (see the Estimating Power Dissipation section), the maximum junction temperature of the FPGA can be found. This is needed to determine if speed derating of the device from the 85 °C junction temperature used in all of the delay tables is needed. Using the maximum ambient temperature, T_{Amax} , and the power dissipated by the device, P , the maximum junction temperature is given by:

$$T_{Jmax} = T_{Amax} + (P \cdot \Theta_{JA})\text{ °C}$$

Table 26 and Table 26 list the thermal characteristics for all packages used with the ORCA 2C Series of FPGAs.

Package Thermal Characteristics (continued)

Table 26. ORCA Plastic Package Thermal Characteristics

Package	Θ_{JA} ($^{\circ}\text{C}/\text{W}$)			Θ_{JC} ($^{\circ}\text{C}/\text{W}$)	Max Power (W) (70 $^{\circ}\text{C}$ —0 fpm)
	0 fpm	200 fpm	400 fpm		
84-Pin PLCC	40	35	32	9	1.38
100-Pin TQFP	61	49	46	6	0.9
144-Pin TQFP	52	39	36	4	1.05
160-Pin QFP	40	36	32	8	1.38
208-Pin SQFP	37	33	29	8	1.49
208-Pin SQFP-PQ2	16	14	12	1.3	3.43
240-Pin SQFP	35	31	28	7	1.57
240-Pin SQFP-PQ2	15	12	10	1.3	3.66
256-Pin PBGA ¹	21	17 (est.)	14 (est.)	TBD	2.62
256-Pin PBGA ²	28	24 (est.)	22 (est.)	TBD	1.97
304-Pin SQFP	33	30	27	6	1.67
304-Pin SQFP-PQ2	12	10	8	1.3	4.58

Notes:

1. With thermal balls connected to board ground plane.

2. Without thermal balls connected to board ground plane.

Table 27. ORCA Ceramic Package Thermal Characteristics

Package	Θ_{JA} ($^{\circ}\text{C}/\text{W}$)			Θ_{JC} ($^{\circ}\text{C}/\text{W}$)	Max Power (W) (70 $^{\circ}\text{C}$ —0 fpm)
	0 fpm	200 fpm	400 fpm		
364-Pin CPGA	18	16	14	2.3	3.05
428-Pin CPGA	18	16	14	2.3	3.05

Package Coplanarity

The coplanarity of Lucent Technologies' postmolded packages is 4 mils. The coplanarity of selected packages is scheduled to be reduced to 3.1 mils. All Lucent ORCA Series FPGA ceramic packages are through-hole mount.

Package Parasitics

The electrical performance of an IC package, such as signal quality and noise sensitivity, is directly affected by the package parasitics. Table 28 lists eight parasitics associated with the ORCA packages. These parasitics represent the contributions of all components of a package, which include the bond wires, all internal package routing, and the external leads.

Four inductances in nH are listed: L_w and L_L , the self-inductance of the lead; and L_{mw} and L_{mL} , the mutual inductance to the nearest neighbor lead. These parameters are important in determining ground bounce

noise and inductive crosstalk noise. Three capacitances in pF are listed: C_M , the mutual capacitance of the lead to the nearest neighbor lead; and C_1 and C_2 , the total capacitance of the lead to all other leads (all other leads are assumed to be grounded). These parameters are important in determining capacitive crosstalk and the capacitive loading effect of the lead.

The parasitic values in Table 28 are for the circuit model of bond wire and package lead parasitics. If the mutual capacitance value is not used in the designer's model, then the value listed as mutual capacitance should be added to each of the C_1 and C_2 capacitors. The PGAs contain power and ground planes that will make the inductance value for power and ground leads the minimum value listed. The PGAs also have a significant range of parasitic values. This is due to the large variation in internal trace lengths and is also due to two signal metal layers that are separated from the ground plane by different distances. The upper signal layer is more inductive but less capacitive than the closer, lower signal layer.

Package Parasitics (continued)

Table 28. ORCA 2C Package Parasitics

Package Type	Lw	Mw	Rw	C1	C2	CM	LL	ML
84-Pin PLCC	3	1	160	1	1	0.5	7—11	3—6
100-Pin TQFP	3	1	160	0.7	0.7	0.94	3—4	1.5—2
144-Pin TQFP	3.5	1.5	175	1	1	0.6	4—6	2—2.5
160-Pin QFP	4	2	200	1	1	1	13—17	8—11
208-Pin SQFP	4	2	200	1	1	1	7—10	4—6
208-Pin SQFP-PQ2	4	2	200	1	1	1	6—9	4—6
240-Pin SQFP	4	2	200	1	1	1	8—12	5—8
240-Pin SQFP-PQ2	4	2	200	1	1	1	7—11	4—7
256-Pin PBGA	5	2	220	1	1	1	5—13	2—6
304-Pin SQFP	5	2	220	1	1	1	12—18	7—12
304-Pin SQFP-PQ2	5	2	220	1	1	1	11—17	7—12
364-Pin CPGA	2	1	1000	1—2	1—2	0.5—1	2—11*	1—4
428-Pin CPGA	2	1	1000	1—2	1—2	0.6—1.2	2—11*	1—4

* Leads designated as ground (power) can be connected to the ground plane, reducing the trace inductance to the minimum value listed.

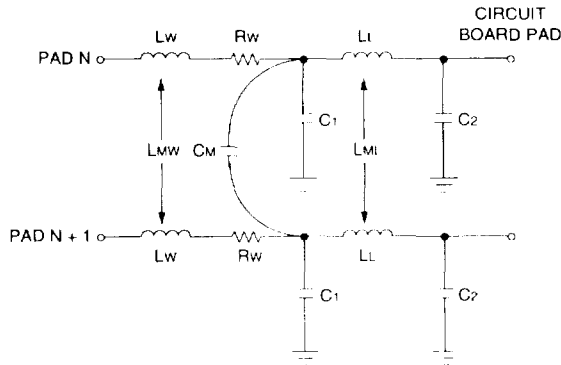

5.3862(C)

Figure 48. Package Parasitics

Absolute Maximum Ratings

Stresses in excess of the Absolute Maximum Ratings can cause permanent damage to the device. These are absolute stress ratings only. Functional operation of the device is not implied at these or any other conditions in excess of those given in the operations sections of this data sheet. Exposure to Absolute Maximum Ratings for extended periods can adversely affect device reliability.

The Lucent ORCA Series FPGAs include circuitry designed to protect the chips from damaging substrate injection currents and prevent accumulations of static charge. Nevertheless, conventional precautions should be observed during storage, handling, and use to avoid exposure to excessive electrical stress.

2

Parameter	Symbol	Min	Max	Unit
Storage Temperature	T _{stg}	-65	150	°C
Supply Voltage with Respect to Ground	V _{DD}	-0.5	7.0	V
Input Signal with Respect to Ground	—	-0.5	V _{DD} + 0.3	V
Signal Applied to High-impedance Output	—	-0.5	V _{DD} + 0.3	V
Maximum Soldering Temperature	—	—	260	°C

Recommended Operating Conditions

Mode	Temperature Range (Ambient)	Supply Voltage
Commercial	0 °C to 70 °C	5 V ± 5%
Industrial	-40 °C to +85 °C	5 V ± 10%

Note: The maximum recommended junction temperature, T_J, during operation is 125 °C.

Electrical Characteristics

Table 29. Electrical Characteristics

 Commercial: $V_{DD} = 5.0\text{ V} \pm 5\%$, $0\text{ }^{\circ}\text{C} \leq T_A \leq 70\text{ }^{\circ}\text{C}$; Industrial: $V_{DD} = 5.0\text{ V} \pm 10\%$, $-40\text{ }^{\circ}\text{C} \leq T_A \leq +85\text{ }^{\circ}\text{C}$.

Parameter	Symbol	Test Conditions	Min	Max	Unit
Input Voltage:		Input configured as CMOS			
High	V_{IH}		70% V_{DD}	$V_{DD} + 0.3$	V
Low	V_{IL}		GND - 0.5	20% V_{DD}	V
Input Voltage:		Input configured as TTL			
High	V_{IH}		2.0	$V_{DD} + 0.3$	V
Low	V_{IL}		-0.5	0.8	V
Output Voltage:					
High	V_{OH}	$V_{DD} = \text{Min}$, $I_{OH} = 6\text{ mA}$ or 3 mA	2.4	—	V
Low	V_{OL}	$V_{DD} = \text{Min}$, $I_{OL} = 12\text{ mA}$ or 6 mA	—	0.4	V
Input Leakage Current	IL	$V_{DD} = \text{Max}$, $V_{IN} = V_{SS}$ or V_{DD}	-10	10	μA
Standby Current:	I_{DDSB}	$T_A = 25\text{ }^{\circ}\text{C}$, $V_{DD} = 5.0\text{ V}$, internal oscillator running, no output loads, inputs at V_{DD} or GND	—		
ATT2C04			—	6.5	mA
ATT2C06			—	7.0	mA
ATT2C08			—	7.7	mA
ATT2C10			—	8.4	mA
ATT2C12			—	9.2	mA
ATT2C15			—	10.0	mA
ATT2C26			—	12.2	mA
ATT2C40			—	16.3	mA
Standby Current:	I_{DDSB}	$T_A = 25\text{ }^{\circ}\text{C}$, $V_{DD} = 5.0\text{ V}$, internal oscillator stopped, no output loads, inputs at V_{DD} or GND	—		
ATT2C04			—	1.5	mA
ATT2C06			—	2.0	mA
ATT2C08			—	2.7	mA
ATT2C10			—	3.4	mA
ATT2C12			—	4.2	mA
ATT2C15			—	5.0	mA
ATT2C26			—	7.2	mA
ATT2C40			—	11.3	mA
Data Retention Voltage	VDR	$T_A = 25\text{ }^{\circ}\text{C}$	2.3	—	V
Input Capacitance	C_{IN}	$T_A = 25\text{ }^{\circ}\text{C}$, $V_{DD} = 5.0\text{ V}$ Test frequency = 1 MHz	—	10	pF
Output Capacitance	C_{OUT}	$T_A = 25\text{ }^{\circ}\text{C}$, $V_{DD} = 5.0\text{ V}$ Test frequency = 1 MHz	—	10	pF
DONE Pull-up Resistor	R _{DONE}	—	100K	—	Ω
M3, M2, M1, and M0 Pull-up Resistors	R _M	—	100K	—	Ω
I/O Pad Static Pull-up Current	I _{PU}	$V_{DD} = 5.25\text{ V}$, $V_{IN} = V_{SS}$, $T_A = 0\text{ }^{\circ}\text{C}$	14.4	50.9	μA
I/O Pad Static Pull-down Current	I _{PD}	$V_{DD} = 5.25\text{ V}$, $V_{IN} = V_{DD}$, $T_A = 0\text{ }^{\circ}\text{C}$	26	103	μA
I/O Pad Pull-up Resistor	R _{PU}	$V_{DD} = 5.25\text{ V}$, $V_{IN} = V_{SS}$, $T_A = 0\text{ }^{\circ}\text{C}$	100K	—	Ω
I/O Pad Pull-down Resistor	R _{PD}	$V_{DD} = 5.25\text{ V}$, $V_{IN} = V_{DD}$, $T_A = 0\text{ }^{\circ}\text{C}$	50K	—	Ω

Timing Characteristics

Table 30. PFU Timing Characteristics

Commercial: VDD = 5.0 V ± 5%, 0 °C ≤ TA ≤ 70 °C; Industrial: VDD = 5.0 V ± 10%, -40 °C ≤ TA ≤ +85 °C.

Parameter	Symbol	Speed						Unit
		-2		-3				
		Min	Max	Min	Max	Min	Max	
Input Requirements								
Clock Low Time	TCL	3.2	—	2.5	—			ns
Clock High Time	TCH	3.2	—	2.5	—			ns
Global S/R Pulse Width (gsrn)	TRW	2.8	—	2.5	—			ns
Local S/R Pulse Width	TPW	3.0	—	2.5	—			ns
Combinatorial Setup Times (TJ = +85 °C, VDD = Min):								
Four Input Variables to Clock (a[4:0], b[4:0] to ck)	F4* SET	2.4	—	1.7	—			ns
Five Input Variables to Clock (a[4:0], b[4:0] to ck)	F5* SET	2.5	—	1.9	—			ns
PFUMUX to Clock (a[4:0], b[4:0] to ck)	MUX_SET	3.9	—	2.9	—			ns
PFUMUX to Clock (c0 to ck)	COMUX_SET	1.5	—	1.2	—			ns
PFUNAND to Clock (a[4:0], b[4:0] to ck)	ND SET	3.9	—	2.9	—			ns
PFUNAND to Clock (c0 to ck)	C0ND_SET	1.7	—	1.2	—			ns
PFUXOR to Clock (a[4:0], b[4:0] to ck)	XOR SET	4.8	—	3.6	—			ns
PFUXOR to Clock (c0 to ck)	C0XOR_SET	1.6	—	1.2	—			ns
Data In to Clock (wd[3:0] to ck)	D* SET	0.5	—	0.1	—			ns
Clock Enable to Clock (ce to ck)	CKEN_SET	1.6	—	1.2	—			ns
Local Set/Reset (synchronous) (lsr to ck)	LSR_SET	1.7	—	1.4	—			ns
Data Select to Clock (sel to ck)	SELECT_SET	1.9	—	1.5	—			ns
Pad Direct In	PDIN_SET	0.0	—	0.0	—			ns
Combinatorial Hold Times (TJ = All, VDD = All):								
Data In (wd[3:0] from ck)	D* HLD	0.6	—	0.4	—			ns
Clock Enable (ce from ck)	CKEN_HLD	0.6	—	0.4	—			ns
Local Set/Reset (synchronous) (lsr from ck)	LSR_HLD	0.0	—	0.0	—			ns
Data Select (sel from ck)	SELECT_HLD	0.0	—	0.0	—			ns
Pad Direct In Hold (dia[3:0], dib[3:0] to ck)	PDIN_HLD	1.5	—	1.4	—			ns
All Others	—	0	—	0	—			ns
Output Characteristics								
Combinatorial Delays (TJ = +85 °C, VDD = Min):								
Four Input Variables (a[4:0], b[4:0] to o[4:0])	F4* DEL	—	5.1	—	3.6			ns
Five Input Variables (a[4:0], b[4:0] to o[4:0])	F5* DEL	—	5.2	—	3.7			ns
PFUMUX (a[4:0], b[4:0] to o[4:0])	MUX_DEL	—	5.8	—	4.6			ns
PFUMUX (c0 to o[4:0])	COMUX_DEL	—	4.1	—	3.0			ns
PFUNAND (a[4:0], b[4:0] to o[4:0])	ND DEL	—	5.8	—	4.8			ns
PFUNAND (c0 to o[4:0])	C0ND_DEL	—	3.8	—	3.0			ns
PFUXOR (a[4:0], b[4:0] to o[4:0])	XOR_DEL	—	6.7	—	5.3			ns
PFUXOR (c0 to o[4:0])	C0XOR_DEL	—	4.2	—	3.0			ns
Sequential Delays (TJ = +85 °C, VDD = Min):								
Local S/R (async) to PFU Out (lsr to o[4:0])	LSR_DEL	—	5.6	—	4.2			ns
Global S/R to PFU Out (gsrn to o[4:0])	GSR_DEL	—	4.0	—	3.1			ns
Clock to PFU Out (ck to o[4:0]) — Register	REG_DEL	—	3.9	—	2.8			ns
Clock to PFU Out (ck to o[4:0]) — Latch	LTCH_DEL	—	4.0	—	2.8			ns
Transparent Latch (wd[3:0] to o[4:0])	LTCH_DDEL	—	5.0	—	3.5			ns

2

Timing Characteristics (continued)

Table 30. PFU Timing Characteristics (continued)

Commercial: VDD = 5.0 V ± 5%, 0 °C ≤ TA ≤ 70 °C; Industrial: VDD = 5.0 V ± 10%, -40 °C ≤ TA ≤ +85 °C.

Parameter	Symbol	Speed						Unit
		-2		-3				
		Min	Max	Min	Max	Min	Max	
Ripple Mode Characteristics								
Ripple Setup Times (TJ = +85 °C, VDD = Min):								
Operands to Clock (a[3:0], b[3:0] to ck)	RIP_SET	6.7	—	5.0	—		ns	
Carry-In to Clock (cin to ck)	CIN_SET	4.0	—	3.2	—		ns	
Add/Subtract to Clock (a4 to ck)	AS_SET	8.2	—	5.6	—		ns	
Ripple Hold Times (TJ = All, VDD = All): All	TH	0	—	0	—		ns	
Ripple Delays (TJ = +85 °C, VDD = Min):								
Operands to Carry-Out (a[3:0], b[3:0] to cout)	RIP_CODEL	—	5.4	—	3.8		ns	
Operands to Carry-Out (o4) (a[3:0], b[3:0] to o4)	RIP_O4DEL	—	6.9	—	4.8		ns	
Operands to PFU Out (a[3:0], b[3:0] to o[4:0])	RIP_DEL	—	9.3	—	6.8		ns	
Carry-In to Carry-Out (cin to cout)	CIN_CODEL	—	1.9	—	1.6		ns	
Carry-In to Carry-Out (o4) (cin to o4)	CIN_O4DEL	—	3.5	—	2.6		ns	
Carry-In to PFU Out (cin to o[4:0])	CIN_DEL	—	6.7	—	5.0		ns	
Add/Subtract to Carry-Out (a4 to cout)	AS_CODEL	—	6.1	—	4.5		ns	
Add/Subtract to Carry-Out (o4) (a4 to o4)	AS_O4DEL	—	7.6	—	5.6		ns	
Add/Subtract to PFU Out (a4 to o[4:0])	AS_DEL	—	10.8	—	7.6		ns	
Read/Write Memory Characteristics								
Read Operation (TJ = +85 °C, VDD = Min):								
Read Cycle Time	TRC	5.1	—	3.6	—		ns	
Data Valid after Address (a[3:0], b[3:0] to o[4:0])	MEM*_ADEL	—	5.1	—	3.6		ns	
Read Operation, Clocking Data into Latch/Flip-Flop (TJ = +85 °C, VDD = Min):								
Address to Clock Setup Time (a[3:0], b[3:0] to ck)	MEM*_ASET	2.4	—	1.8	—		ns	
Clock to PFU Out (ck to o[4:0]) — Register	REG_DEL	—	3.9	—	2.8		ns	
Write Operation (TJ = +85 °C, VDD = Min):								
Write Cycle Time	TWC	5.5	—	4.5	—		ns	
Write Enable Pulse Width (a4/b4)	TPW	3.0	—	2.5	—		ns	
Setup Time (TJ = +85 °C, VDD = Min):								
Address to wren (a[3:0]/b[3:0] to a4/b4)	MEM*_AWRSET	0.1	—	0.1	—		ns	
Data to wren (wd[3:0] to a4/b4)	MEM*_DWRSET	0.0	—	0.0	—		ns	
Hold Time (TJ = All, VDD = All):								
Address from wren (a[3:0]/b[3:0] from a4/b4)	MEM*_WRAHLD	2.4	—	1.7	—		ns	
Data from wren (wd[3:0] from a4/b4)	MEM*_WRDHLd	2.4	—	2.0	—		ns	

2

Timing Characteristics (continued)

Table 30. PFU Timing Characteristics (continued)

Commercial: VDD = 5.0 V ± 5%, 0 °C ≤ TA ≤ 70 °C; Industrial: VDD = 5.0 V ± 10%, -40 °C ≤ TA ≤ +85 °C.

Parameter	Symbol	Speed						Unit
		-2		-3				
		Min	Max	Min	Max	Min	Max	
Read During Write Operation (TJ = +85 °C, VDD = Min)								
Write Enable to PFU Output Delay (a4/b4 to o[4:0])	MEM*_WRDEL	—	8.1	—	5.7			ns
Data to PFU Output Delay (wd[3:0] to o[4:0])	MEM*_DDEL	—	6.1	—	4.4			ns
Read During Write, Clocking Data into Latch/Flip-Flop								
Setup Time (TJ = +85 °C, VDD = Min):								
Write Enable to Clock (a4/b4 to ck)	MEM*_WRSET	5.4	—	4.4	—			ns
Data (wd[3:0] to ck)	MEM*_DSET	3.5	—	2.6	—			ns
Hold Time (TJ = All, VDD = All): All	TH	0	—	0	—			ns
Clock to PFU Out (ck to o[4:0]) — Register	REG_DEL	—	3.9	—	2.8			ns

2

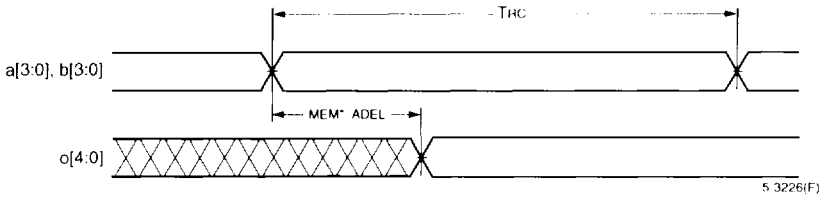

Figure 49. Read Operation—Flip-Flop Bypass

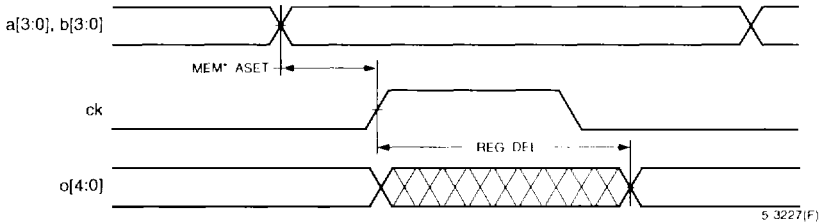

Figure 50. Read Operation—LUT Memory Loading Flip-Flops

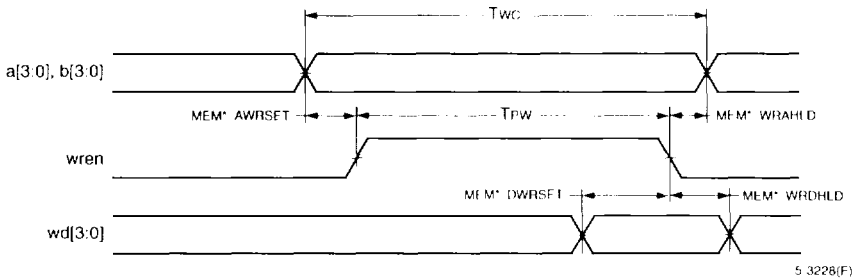

Figure 51. Write Operation

Timing Characteristics (continued)

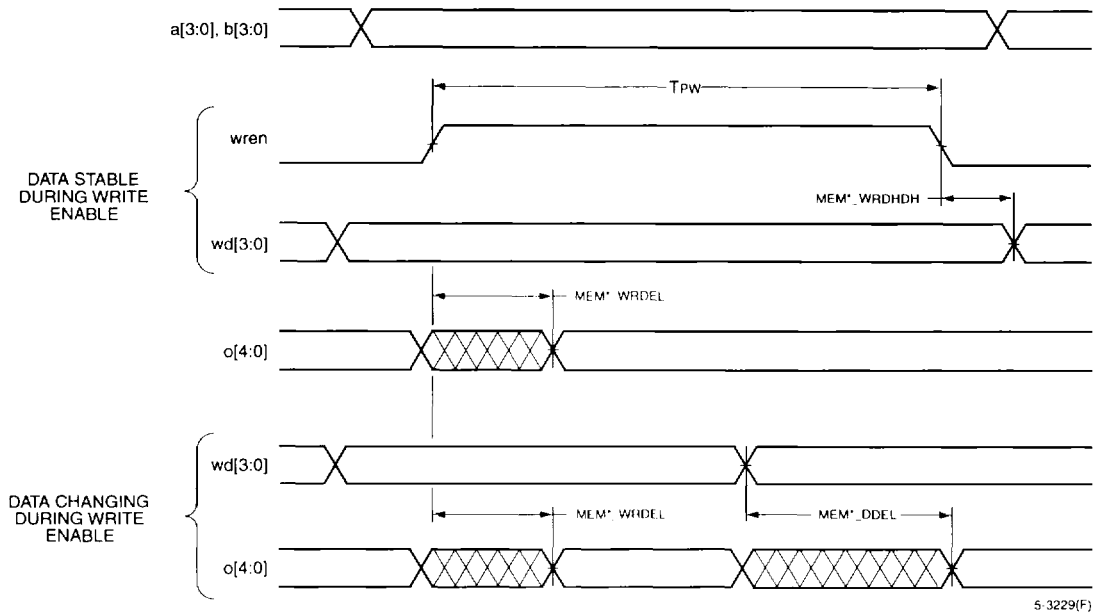

Figure 52. Read During Write

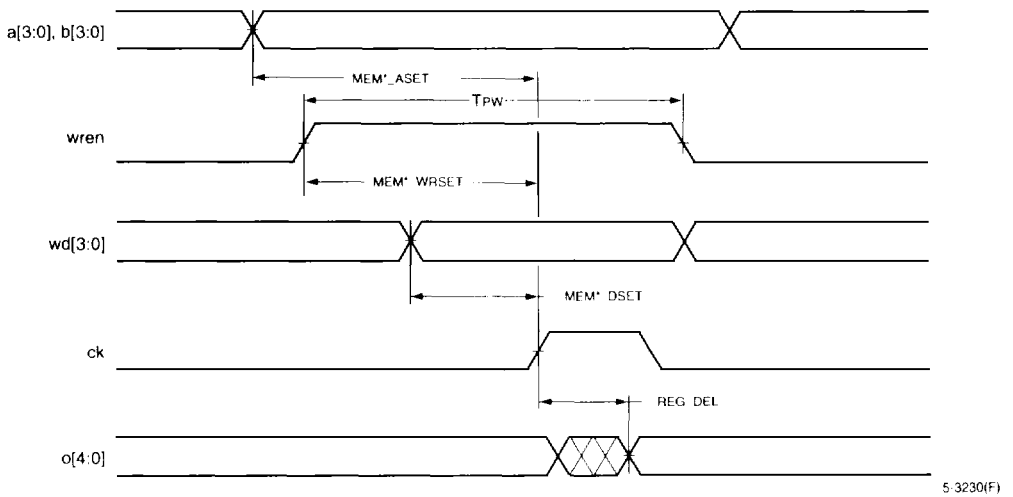

Figure 53. Read During Write—Clocking Data into Flip-Flop

Timing Characteristics (continued)

Table 31. PLC BIDI and Direct Routing Timing Characteristics

 Commercial: $V_{DD} = 5.0\text{ V} \pm 5\%$, $0\text{ }^{\circ}\text{C} \leq T_A \leq 70\text{ }^{\circ}\text{C}$; Industrial: $V_{DD} = 5.0\text{ V} \pm 10\%$, $-40\text{ }^{\circ}\text{C} \leq T_A \leq +85\text{ }^{\circ}\text{C}$.

Parameter	Symbol	Speed						Unit
		-2		-3				
		Min	Max	Min	Max	Min	Max	
PLC 3-Statable BIDs ($T_J = +85\text{ }^{\circ}\text{C}$, $V_{DD} = \text{Min}$)								
BIDI Propagation Delay	TRI_DEL	—	1.2	—	1.0			ns
BIDI 3-State Enable/Disable Delay	TRIEN_DEL	—	1.7	—	1.3			ns
Direct Routing ($T_J = +85\text{ }^{\circ}\text{C}$, $V_{DD} = \text{Min}$)								
PFU to PFU Delay (xSW)	DIR_DEL	—	1.4	—	1.1			ns
PFU Feedback (xSW)	FDBK_DEL	—	1.0	—	0.8			ns

Table 32. Clock Delay

 Commercial: $V_{DD} = 5.0\text{ V} \pm 5\%$, $0\text{ }^{\circ}\text{C} \leq T_A \leq 70\text{ }^{\circ}\text{C}$; Industrial: $V_{DD} = 5.0\text{ V} \pm 10\%$, $-40\text{ }^{\circ}\text{C} \leq T_A \leq +85\text{ }^{\circ}\text{C}$.

Device ($T_J = +85\text{ }^{\circ}\text{C}$, $V_{DD} = \text{Min}$)	Symbol	Speed						Unit
		-2		-3				
		Min	Max	Min	Max	Min	Max	
ATT2C04	CLK_DEL	—	5.5	—	4.4			
ATT2C06	CLK_DEL	—	5.6	—	4.5			ns
ATT2C08	CLK_DEL	—	5.8	—	4.6			ns
ATT2C10	CLK_DEL	—	5.9	—	4.7			ns
ATT2C12	CLK_DEL	—	6.1	—	4.9			ns
ATT2C15	CLK_DEL	—	6.2	—	5.0			ns
ATT2C26	CLK_DEL	—	6.4	—	5.2			ns
ATT2C40	CLK_DEL	—	6.9	—	5.8			ns

Note: This clock delay is for a fully routed clock tree that uses the primary clock network. It includes both the input buffer delay and the clock routing to the PFU CLK input. The delay will be reduced if any of the clock branches are not used.

Timing Characteristics (continued)

Table 33. Programmable I/O Cell Timing Characteristics

Commercial: VDD = 5.0 V ± 5%, 0 °C ≤ TA ≤ 70 °C; Industrial: VDD = 5.0 V ± 10%, -40 °C ≤ TA ≤ +85 °C; CL = 50 pF.

Parameter	Symbol	Speed						Unit
		-2		-3				
		Min	Max	Min	Max	Min	Max	
Inputs (TJ = +85 °C, VDD = Min)								
Input Rise Time	TR	—	500	—	500			ns
Input Fall Time	TF	—	500	—	500			ns
Pad to In Delay	FASTIN_G_DEL	—	3.1	—	2.3			ns
Pad to TRIDI Delay	FASTIN_L_DEL	—	2.7	—	1.9			ns
Pad to In Delay (delay mode)	DLYIN_G_DEL	—	7.8	—	6.2			ns
Pad to TRIDI Delay (delay mode)	DLYIN_L_DEL	—	2.5	—	1.9			ns
Pad to Nearest PFU Latch Output	CHIP_LATCH	—	6.8	—	5.1			ns
Setup Time: Pad to Nearest PFU ck Pad to Nearest PFU ck (delay mode)*	CHIP_SET DLY_CHIP_SET	2.8 8.7	— —	2.1 6.8	— —			ns ns
Outputs (TJ = +85 °C, VDD = Min)								
PFU ck to Pad Delay (dout[3:0] to pad): Fast Slewlim Sinklim	DOUT_DEL(F) DOUT_DEL(SL) DOUT_DEL(SI)	— — —	7.6 9.3 12.4	— — —	5.7 6.9 8.9			ns ns ns
Output to Pad Delay (out[3:0] to pad): Fast Slewlim Sinklim	OUT_DEL(F) OUT_DEL(SL) OUT_DEL(SI)	— — —	5.0 6.7 9.8	— — —	4.0 5.2 7.2			ns ns ns
3-state Enable Delay (ts[3:0] to pad): Fast Slewlim Sinklim	TS_DEL(F) TS_DEL(SL) TS_DEL(SI)	— — —	5.8 7.5 10.6	— — —	4.7 5.9 7.9			ns ns ns

* If the input buffer is placed in delay mode, the chip hold time to the nearest PFU latch is guaranteed to be 0 if the clock is routed using the primary clock network; (TJ = All, VDD = All). For the ATT2C40, this is only valid for input buffers on the same half of the device as the clock pin.

Note: The delays for all input buffers assume an input rise/fall time of ≤1 V/ns.

2

Timing Characteristics (continued)

Table 34. General Configuration Mode Timing Characteristics

Commercial: VDD = 5.0 V ± 5%, 0 °C ≤ TA ≤ 70 °C; Industrial: VDD = 5.0 V ± 10%, -40 °C ≤ TA ≤ +85 °C; CL = 50 pF.

Parameter	Symbol	Min	Max	Unit
All Configuration Modes				
M[3:0] Setup Time to INIT High	TSMODE	50.0	—	ns
M[3:0] Hold Time from INIT High	THMODE	600.0	—	ns
RESET Pulse Width Low	TRW	50.0	—	ns
PRGM Pulse Width Low	TPGW	50.0	—	ns
Master and Asynchronous Peripheral Modes				
Power-on Reset Delay	TPO	16.24	43.80	ms
CCLK Period (M3 = 0)	TCCLK	62.00	167.00	ns
(M3 = 1)		496.00	1336.00	ns
Configuration Latency (noncompressed)	TCL			
ATT2C04 (M3 = 0)		4.05	10.90*	ms
(M3 = 1)		32.38	87.21*	ms
ATT2C06 (M3 = 0)		5.63	15.18*	ms
(M3 = 1)		45.08	121.42*	ms
ATT2C08 (M3 = 0)		7.16	19.28*	ms
(M3 = 1)		57.27	154.25*	ms
ATT2C10 (M3 = 0)		9.23	24.85*	ms
(M3 = 1)		73.80	198.80*	ms
ATT2C12 (M3 = 0)		11.14	30.01*	ms
(M3 = 1)		89.14	240.10*	ms
ATT2C15 (M3 = 0)		13.69	36.87*	ms
(M3 = 1)		109.52	294.99*	ms
ATT2C26 (M3 = 0)		19.03	51.25*	ms
(M3 = 1)		152.28	409.99*	ms
ATT2C40 (M3 = 0)		29.39	79.16*	ms
(M3 = 1)		235.12	633.31*	ms
Slave Serial and Synchronous Peripheral Modes				
Power-on Reset Delay	TPO	4.06	10.95	ms
CCLK Period	TCCLK	100.00	—	ns
Configuration Latency (noncompressed):	TCL			
ATT2C04		6.53	—	ms
ATT2C06		9.09	—	ms
ATT2C08		11.55	—	ms
ATT2C10		14.88	—	ms
ATT2C12		17.97	—	ms
ATT2C15		22.08	—	ms
ATT2C26		30.69	—	ms
ATT2C40		47.40	—	ms

* Not applicable to asynchronous peripheral mode.

Timing Characteristics (continued)

Table 34. General Configuration Mode Timing Characteristics (continued)

Commercial: VDD = 5.0 V ± 5%, 0 °C ≤ TA ≤ 70 °C; Industrial: VDD = 5.0 V ± 10%, -40 °C ≤ TA ≤ +85 °C; CL = 50 pF.

Parameter	Symbol	Min	Max	Unit
Slave Parallel Mode				
Power-on Reset Delay	TPO	4.06	10.95	ms
CCLK Period	TCCLK	100.00	—	ns
Configuration Latency (noncompressed):	TCL			
ATT2C04		0.82	—	ms
ATT2C06		1.14	—	ms
ATT2C08		1.44	—	ms
ATT2C10		1.86	—	ms
ATT2C12		2.25	—	ms
ATT2C15		2.76	—	ms
ATT2C26		3.84	—	ms
ATT2C40		5.93	—	ms
INIT Timing				
INIT High to CCLK Delay	TINIT CCLK			
Slave Parallel		1.00	—	μs
Slave Serial		1.00	—	μs
Synchronous Peripheral		1.00	—	μs
Master Serial				
M3 = 1		1.00	2.90	μs
M3 = 0		0.50	0.70	μs
Master Parallel				
M3 = 1		4.90	13.60	μs
M3 = 0		1.00	2.90	μs
Initialization Latency (PRGM high to INIT high)	TIL			
ATT2C04		59.51	162.33	μs
ATT2C06		70.43	191.72	μs
ATT2C08		81.34	221.11	μs
ATT2C10		92.25	250.51	μs
ATT2C12		103.16	279.90	μs
ATT2C15		114.07	309.29	μs
ATT2C26		135.90	368.07	μs
ATT2C40		170.87	462.26	μs
INIT High to WR, Asynchronous Peripheral	TINIT WR	1.50	—	μs

Note: TPO is triggered when VDD reaches between 3.0 V to 4.0 V.

Timing Characteristics (continued)

2

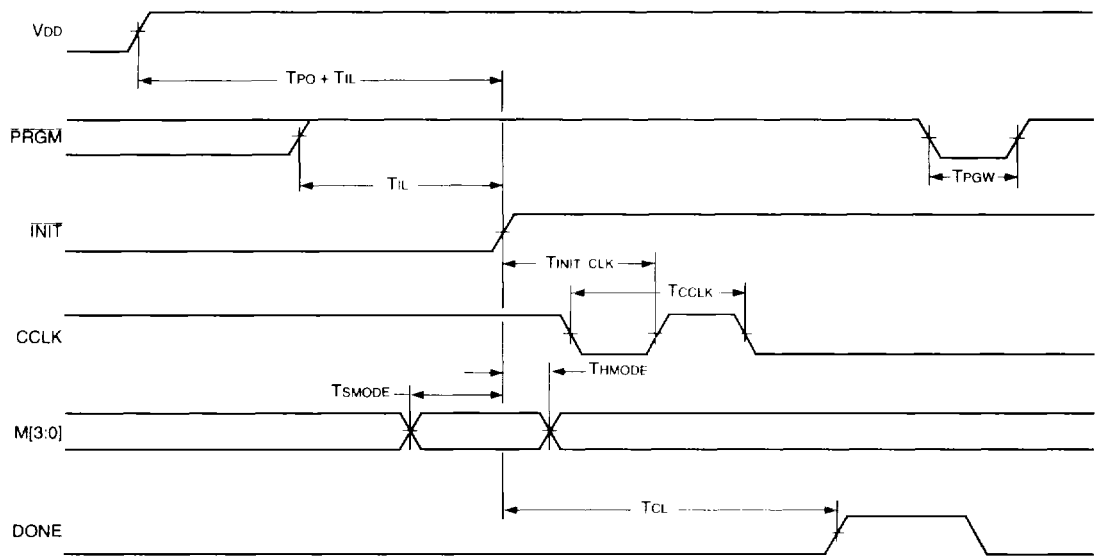

5-4531(F)

Figure 54. General Configuration Mode Timing Diagram

Timing Characteristics (continued)

Table 35. Master Serial Configuration Mode Timing Characteristics

Commercial: $V_{DD} = 5.0\text{ V} \pm 5\%$, $0\text{ }^{\circ}\text{C} \leq T_A \leq 70\text{ }^{\circ}\text{C}$; Industrial: $V_{DD} = 5.0\text{ V} \pm 10\%$, $-40\text{ }^{\circ}\text{C} \leq T_A \leq +85\text{ }^{\circ}\text{C}$; $C_L = 50\text{ pF}$.

Parameter	Symbol	Min	Nom	Max	Unit
DIN Setup Time	T_S	60.0	—	—	ns
DIN Hold Time	T_H	0	—	—	ns
CCLK Frequency (M3 = 0)	F_C	6.0	10.0	16.0	MHz
CCLK Frequency (M3 = 1)	F_C	0.75	1.25	2.0	MHz
CCLK to DOUT Delay	T_D	—	—	30	ns

Note: Serial configuration data is transmitted out on DOUT on the falling edge of CCLK after it is input DIN.

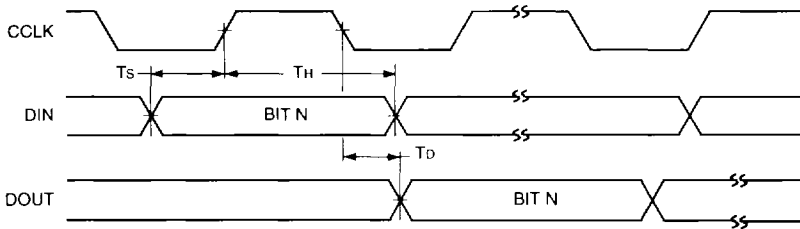

5-4532(F)

Figure 55. Master Serial Configuration Mode Timing Diagram

Timing Characteristics (continued)

Table 36. Master Parallel Configuration Mode Timing Characteristics

Commercial: VDD = 5.0 V ± 5%, 0 °C ≤ TA ≤ 70 °C; Industrial: VDD = 5.0 V ± 10%, -40 °C ≤ TA ≤ +85 °C; CL = 50 pF.

Parameter	Symbol	Min	Max	Unit
RCLK to Address Valid	TAV	0	200	ns
D[7:0] Setup Time to RCLK High	Ts	60	—	ns
D[7:0] Hold Time to RCLK High	TH	0	—	ns
RCLK Low Time (M3 = 0)	TCL	434	1169	ns
RCLK High Time (M3 = 0)	TCH	62	167	ns
RCLK Low Time (M3 = 1)	TCL	3472	9352	ns
RCLK High Time (M3 = 1)	TCH	496	1336	ns
CCLK to DOUT	TD	—	30	ns

Notes: The RCLK period consists of seven CCLKs for RCLK low and one CCLK for RCLK high.
Serial data is transmitted out on DOUT 1.5 CCLK cycles after the byte is input D[7:0].

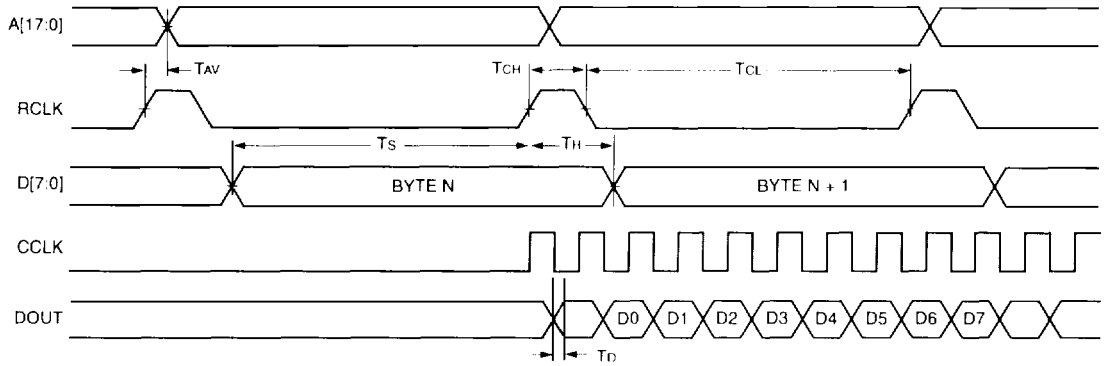

144(F)

Figure 56. Master Parallel Configuration Mode Timing Diagram

Timing Characteristics (continued)

Table 37. Asynchronous Peripheral Configuration Mode Timing Characteristics

Commercial: VDD = 5.0 V ± 5%, 0 °C ≤ TA ≤ 70 °C; Industrial: VDD = 5.0 V ± 10%, -40 °C ≤ TA ≤ +85 °C; CL = 50 pF.

Parameter	Symbol	Min	Max	Unit
WR, CS0, and CS1 Pulse Width	TWR	100	—	ns
D[7:0] Setup Time	Ts	20	—	ns
D[7:0] Hold Time	TH	0	—	ns
RDY/BUSY Delay	TRDY	—	60	ns
RDY/BUSY Low	TB	2	9	CCLK Periods
Earliest WR After End of BUSY	TWR2	0	—	ns
CCLK to DOUT	Td	—	30	ns

Note: Serial data is transmitted out on DOUT on the falling edge of CCLK after the byte is input D[7:0].

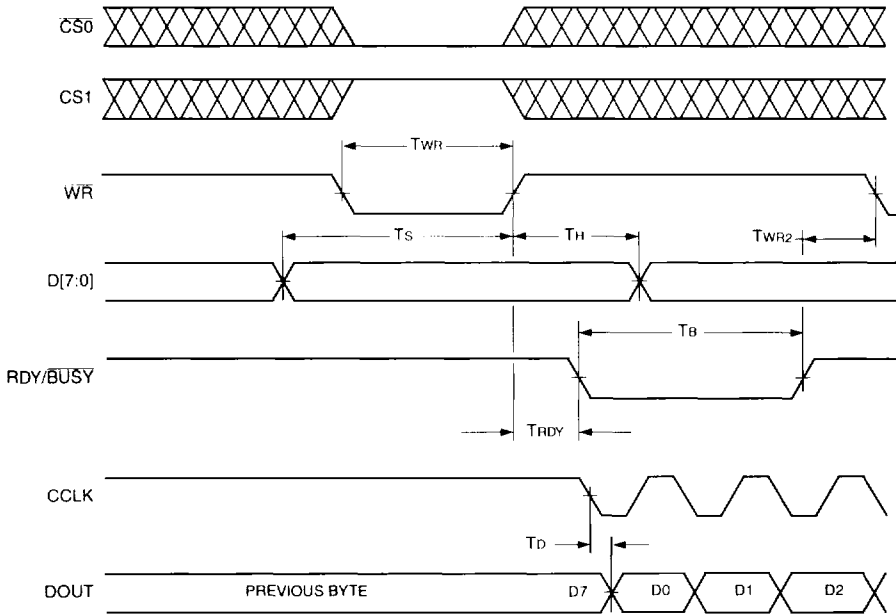

5-4533(F)

Figure 57. Asynchronous Peripheral Configuration Mode Timing Diagram

Timing Characteristics (continued)

Table 38. Synchronous Peripheral Configuration Mode Timing Characteristics

Commercial: $V_{DD} = 5.0\text{ V} \pm 5\%$, $0\text{ }^{\circ}\text{C} \leq T_A \leq 70\text{ }^{\circ}\text{C}$; Industrial: $V_{DD} = 5.0\text{ V} \pm 10\%$, $-40\text{ }^{\circ}\text{C} \leq T_A \leq +85\text{ }^{\circ}\text{C}$; $C_L = 50\text{ pF}$.

Parameter	Symbol	Min	Max	Unit
D[7:0] Setup Time	T_S	20	—	ns
D[7:0] Hold Time	T_H	0	—	ns
CCLK High Time	T_{CH}	50	—	ns
CCLK Low Time	T_{CL}	50	—	ns
CCLK Frequency	F_C	—	10	MHz
CCLK to DOUT	T_D	—	30	ns

Note: Serial data is transmitted out on DOUT 1.5 clock cycles after the byte is input D[7:0].

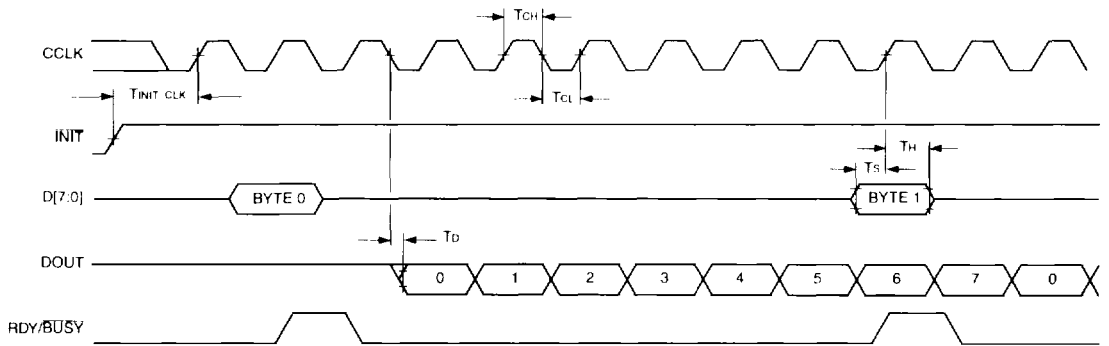

5-4534(F)

Figure 58. Synchronous Peripheral Configuration Mode Timing Diagram

Timing Characteristics (continued)

Table 39. Slave Serial Configuration Mode Timing Characteristics

Commercial: $V_{DD} = 5.0 \pm 5\%$, $0^\circ\text{C} \leq T_A \leq 70^\circ\text{C}$; Industrial: $V_{DD} = 5.0\text{ V} \pm 10\%$, $-40^\circ\text{C} \leq T_A \leq +85^\circ\text{C}$; $C_L = 50\text{ pF}$.

Parameter	Symbol	Min	Max	Unit
DIN Setup Time	T_S	20	—	ns
DIN Hold Time	T_H	0	—	ns
CCLK High Time	T_{CH}	50	—	ns
CCLK Low Time	T_{CL}	50	—	ns
CCLK Frequency	F_C	—	10	MHz
CCLK to DOUT	T_D	—	30	ns

Note: Serial configuration data is transmitted out on DOUT on the falling edge of CCLK after it is input on DIN.

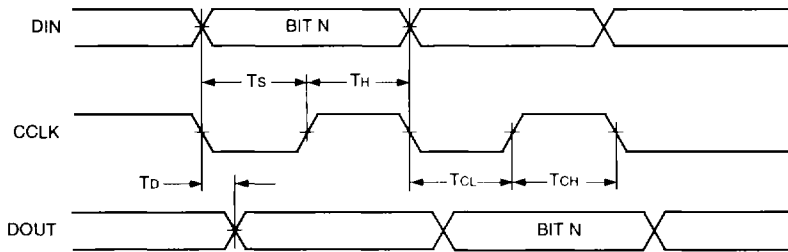

5-4535(F)

Figure 59. Slave Serial Configuration Mode Timing Diagram

Timing Characteristics (continued)

Table 40. Slave Parallel Configuration Mode Timing Characteristics

Commercial: $V_{DD} = 5.0\text{ V} \pm 5\%$, $0\text{ }^{\circ}\text{C} \leq T_A \leq 70\text{ }^{\circ}\text{C}$; Industrial: $V_{DD} = 5.0\text{ V} \pm 10\%$, $-40\text{ }^{\circ}\text{C} \leq T_A \leq +85\text{ }^{\circ}\text{C}$.

Parameter	Symbol	Min	Max	Unit
CS0, CS1, WR Setup Time	TS1	60	—	ns
CS0, CS1, WR Hold Time	TH1	20	—	ns
D[7:0] Setup Time	TS2	20	—	ns
D[7:0] Hold Time	TH2	0	—	ns
CCLK High Time	TCH	50	—	ns
CCLK Low Time	TCL	50	—	ns
CCLK Frequency	Fc	—	10	MHz

Note: Daisy chaining of FPGAs is not supported in this mode.

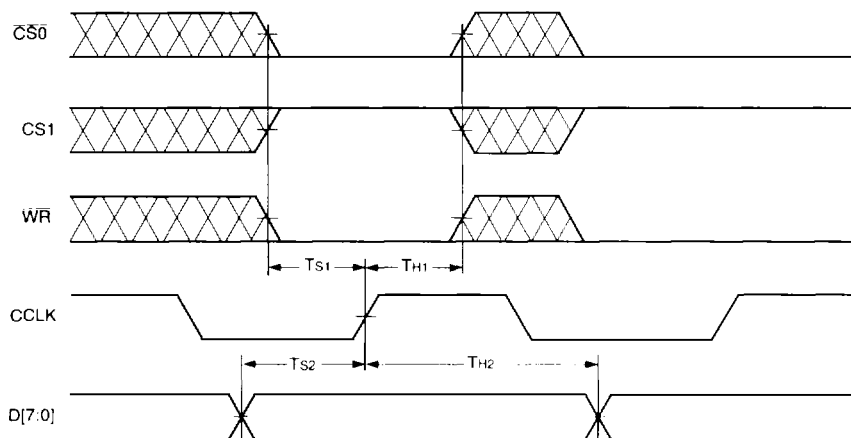

5 2848(F)

Figure 60. Slave Parallel Configuration Mode Timing Diagram

Timing Characteristics (continued)

Table 41. Readback Timing Characteristics

Commercial: $V_{DD} = 5.0\text{ V} \pm 5\%$, $0\text{ }^{\circ}\text{C} \leq T_A \leq 70\text{ }^{\circ}\text{C}$; Industrial: $V_{DD} = 5.0\text{ V} \pm 10\%$, $-40\text{ }^{\circ}\text{C} \leq T_A \leq +85\text{ }^{\circ}\text{C}$; $CL = 50\text{ pF}$.

Parameter	Symbol	Min	Max	Unit
RD_CFGN to CCLK Setup Time	T_s	50	—	ns
RD_CFGN High Width to Abort Readback	T_{RBA}	2	—	CCLK
CCLK Low Time	T_{CL}	50	—	ns
CCLK High Time	T_{CH}	50	—	ns
CCLK Frequency	F_C	—	10*	MHz
CCLK to RD_DATA Delay	T_D	—	50	ns

* The maximum readback CCLK frequency for the ATT2C40 is 8 MHz.

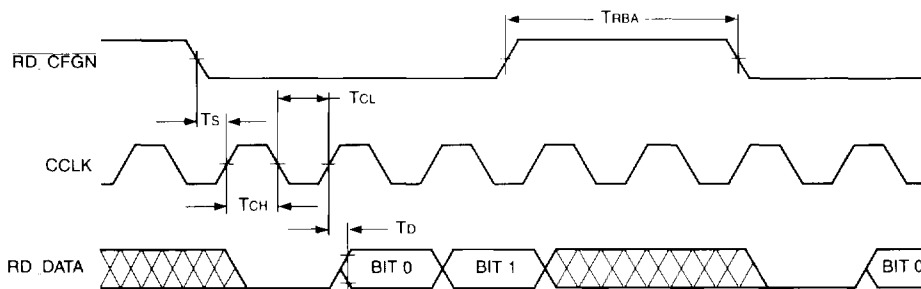

5 4536(F)

Figure 61. Readback Timing Diagram

Timing Characteristics (continued)

Table 42. Boundary-Scan Timing Characteristics

Commercial: $V_{DD} = 5.0\text{ V} \pm 5\%$, $0\text{ }^{\circ}\text{C} \leq T_A \leq 70\text{ }^{\circ}\text{C}$; Industrial: $V_{DD} = 5.0\text{ V} \pm 10\%$, $-40\text{ }^{\circ}\text{C} \leq T_A \leq +85\text{ }^{\circ}\text{C}$; $C_L = 50\text{ pF}$.

Parameter	Symbol	Min	Max	Unit
TDI/TMS to TCK Setup Time	T_s	25	—	ns
TDI/TMS Hold Time from TCK	T_H	0	—	ns
TCK Low Time	T_{CL}	50	—	ns
TCK High Time	T_{CH}	50	—	ns
TCK to TDO Delay	T_D	—	20	ns
TCK Frequency	T_{TCK}	—	10	MHz

2

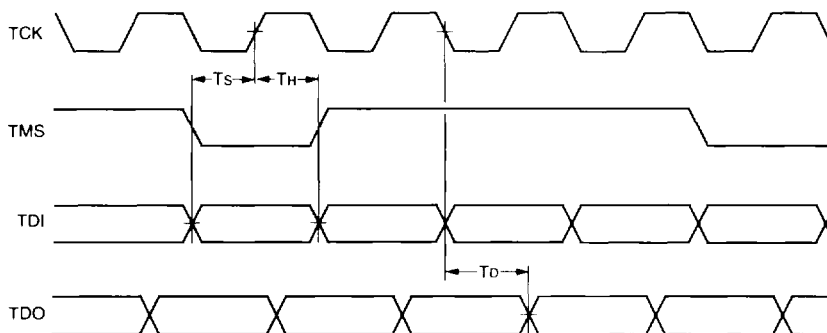

BSTD(C)

Figure 62. Boundary-Scan Timing Diagram

Measurement Conditions

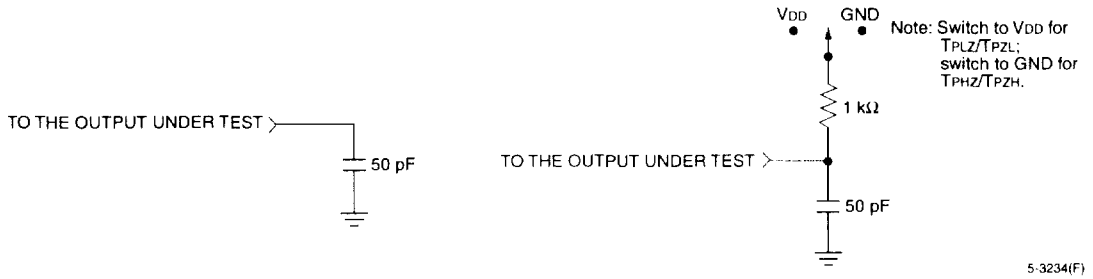

2

A. Load Used to Measure Propagation Delay

B. Load Used to Measure Rising/Falling Edges

Figure 63. ac Test Loads

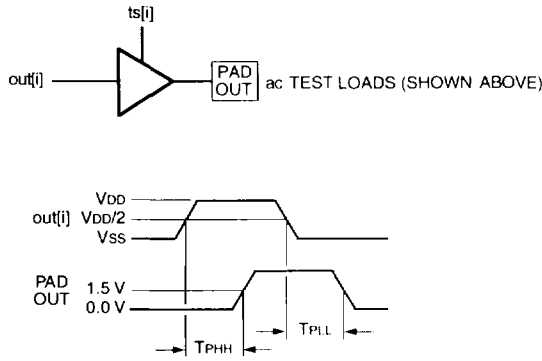

Figure 64. Output Buffer Delays

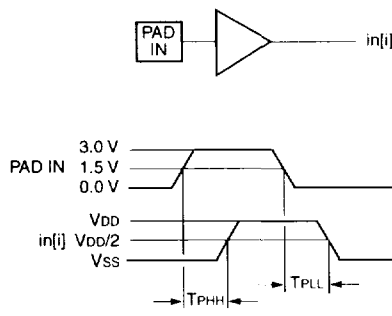
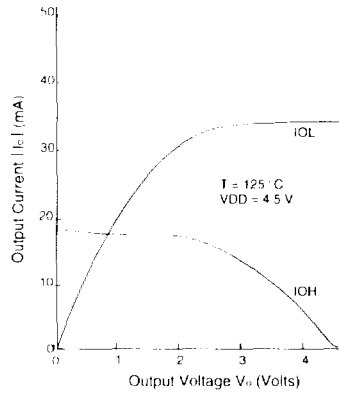
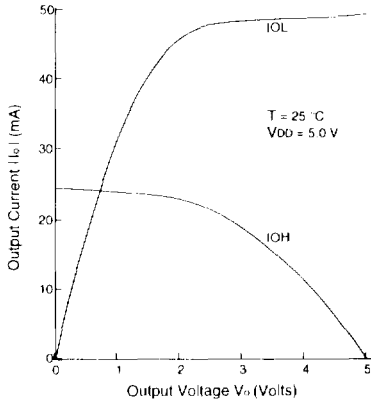

Figure 65. Input Buffer Delays

Output Buffer Characteristics

2



Sinklim

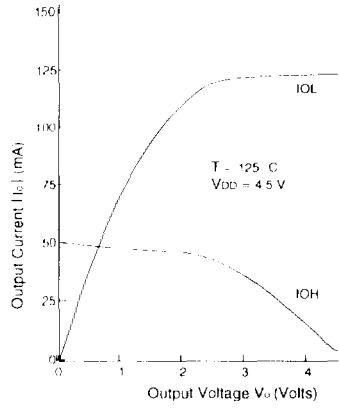
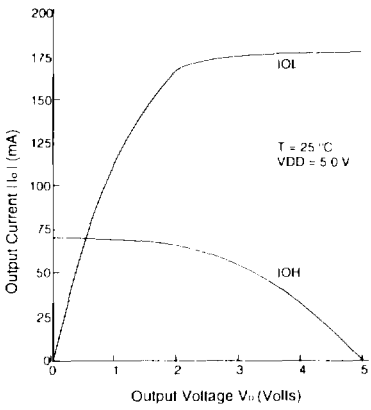

Slewlim

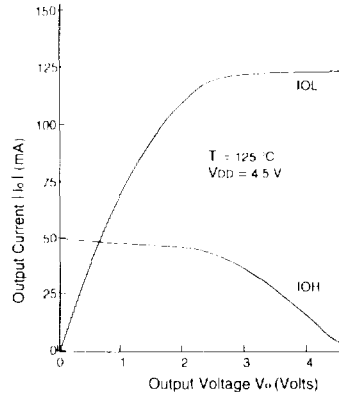
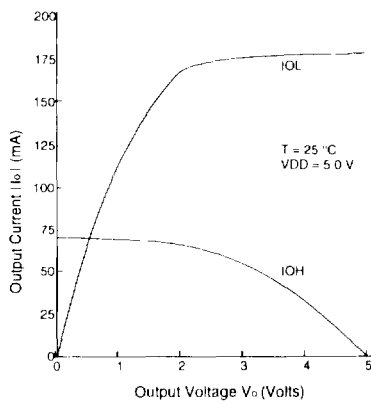

Fast

Ordering Information

Example:

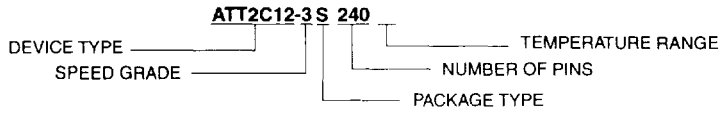

ATT2C12, -3 Speed Grade, 240-pin Shrink Quad Flat Pack, Commercial Temperature.

Table 43. FPGA Temperature Options

Symbol	Description	Temperature
(Blank)	Commercial	0 °C to 70 °C
I	Industrial	-40 °C to +85 °C

Table 44. FPGA Package Options

Symbol	Description
B	Plastic Ball Grid Array (PBGA)
J	Quad Flat Package (QFP)
M	Plastic Leaded Chip Carrier (PLCC)
PS	Power Quad Shrink Flat Package (SQFP-PQ2)
R	Ceramic Pin Grid Array (CPGA)
S	Shrink Quad Flat Package (SQFP)
T	Thin Quad Flat Package (TQFP)

Table 45. ORCA 2C Series Package Matrix

Packages	84-Pin PLCC	100-Pin TQFP	144-Pin TQFP	160-Pin QFP	208-Pin EIAJ SQFP/ SQFP-PQ2	240-Pin EIAJ SQFP/ SQFP-PQ2	256-Pin PBGA	304-Pin EIAJ SQFP/ SQFP-PQ2	364-Pin CPGA	428-Pin CPGA
	M84	T100	T144	J160	S208/ PS208	S240/ PS240	B256	S304/ PS304	R364	R428
ATT2C04	CI	CI	CI	CI	CI	—	—	—	—	—
ATT2C06	CI	CI	CI	CI	CI	CI	—	—	—	—
ATT2C08	CI	—	—	CI	CI	CI	CI	CI	—	—
ATT2C10	CI	—	—	CI	CI	CI	CI	CI	—	—
ATT2C12	—	—	—	—	CI	CI	CI	CI	CI	—
ATT2C15	—	—	—	—	CI	CI	—	CI	CI	—
ATT2C26	—	—	—	—	CI	CI	—	CI	—	CI
ATT2C40	—	—	—	—	CI	CI	—	CI	—	CI

Key: C = commercial, I = industrial.

Note: The package options with the SQFP/SQFP-PQ2 designation in the table above use the SQFP package for all densities up to and including the ATT2C15, while the ATT2C26 uses the SQFP-PQ2 package (chip-up orientation), and the ATT2C40 uses the SQFP-PQ2 package (chip-down orientation).