

- **Compatible with IEEE Std 802.5-1985 Token Ring Access Method and Physical Layer Specifications**
 - Differential Manchester Code Conversion on 4M-Bit per Second Serial Data Stream
 - Address Recognition (Functional, Group and Specific)
 - Manchester Code Violation Detection
 - Starting and Ending Delimiter Generation and Detection
 - CRC Generation and Checking
 - High-Speed Frame Repeat Path Minimizes Ring Latency (2-Bit Times)
 - Token Transmit and Priority Control
 - Monitor Functions
- **Separate Pairs of DMA Channels for Receive and Transmit**
- **Supports Both Universal and Local Ring Addressing**
- **Automatic Frame Buffer Management**
- **External Hardware Interface for User-Defined External Checker Logic**
- **On-Chip 16K-Byte ROM for Adapter Software**
 - 8K x 18-Bit ROM with Byte Parity Protection
 - Single Word Prefetch
- **Plug Compatible with the TMS38020**

**JD PACKAGE
(TOP VIEW)**

VSS3	1	48	FRAQ
RCLK	2	47	DRVR
VCC3	3	46	WRAP
REDY	4	45	RCVR
PXTALIN	5	44	NSRT
LBROP	6	43	WFLT
LBGRP	7	42	XFAIL
LBRDY	8	41	PHTEST
PHCS	9	40	XMATCH
VSS1	10	39	PIRQ
LAD15	11	38	VCC2
LAD14	12	37	VSS2
LAD13	13	36	LR/W
LAD12	14	35	LBCLK1
LAD11	15	34	LBCLK2
LAD10	16	33	LI/D
LAD9	17	32	LEN
LAD8	18	31	LAL
LPL	19	30	PHRESET
VCC1	20	29	LAD0
LPH	21	28	LAD1
LAD7	22	27	LAD2
LAD6	23	26	LAD3
LAD5	24	25	LAD4

- **Test Pin for Hi-Z, Module-in-Place Testing**
- **48-Pin, 600-Mil, Ceramic Dual-in-Line Packaging**
- **Low-Power Scaled-NMOS Technology**

token ring LAN application diagram

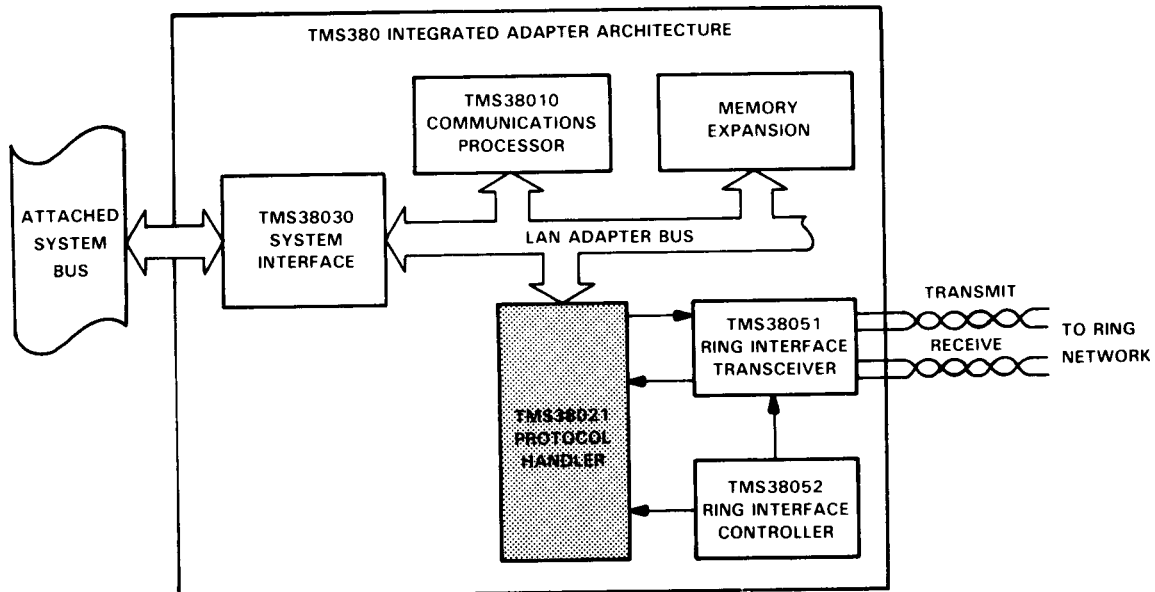

**TMS38021
PROTOCOL HANDLER**

pin descriptions

NAME	I/O	DESCRIPTION
LAN ADAPTER BUS INTERFACE PINS		
LBCLK1, LBCLK2	I	Bus Clocks
$\overline{\text{LAL}}$	I/O	Address Latch Enable
$\overline{\text{LEN}}$	I/O	Data Enable
LBRDY	I/O	Bus Ready
$\overline{\text{PIRQ}}$	O	PH Interrupt Request
$\overline{\text{LBRQP}}$	O	Bus Request
$\overline{\text{LBGRP}}$	I	Bus Grant
LAD0-LAD15	I/O	Address/Data bus. LAD0 is the most-significant bit, LAD15 is the least-significant bit.
LPH, LPL	I/O	Parity High/Parity Low
LI/ $\overline{\text{D}}$	I/O	Instruction/Data Bus Status Code
LR/ $\overline{\text{W}}$	I/O	Read/Not Write
$\overline{\text{PHRESET}}$	I	Reset
$\overline{\text{PHCS}}$	I	Chip Select
RING INTERFACE PINS		
DRVR	O	Transmitter Data
FRAQ	O	Frequency Acquisition Select
$\overline{\text{NSRT}}$	O	Insert Control
RCLK	I	Recovered Data Clock
RCVR	I	Received Data
$\overline{\text{REDY}}$	I	Ring Interface Ready
$\overline{\text{WFLT}}$	I	Wire Fault Detect
$\overline{\text{WRAP}}$	O	Wrap Select
PXTALIN	I	Ring Frequency Reference Clock
MISCELLANEOUS PINS		
$\overline{\text{PHTEST}}$	I	Module-in-Place Test Mode Select. This pin should be left unconnected.
VCC		5-V supply pins.
VSS		Ground pins.
$\overline{\text{XMATCH}}$	I/O	External frame match select.
$\overline{\text{XFAIL}}$	I/O	External frame fail select.

functional block diagram

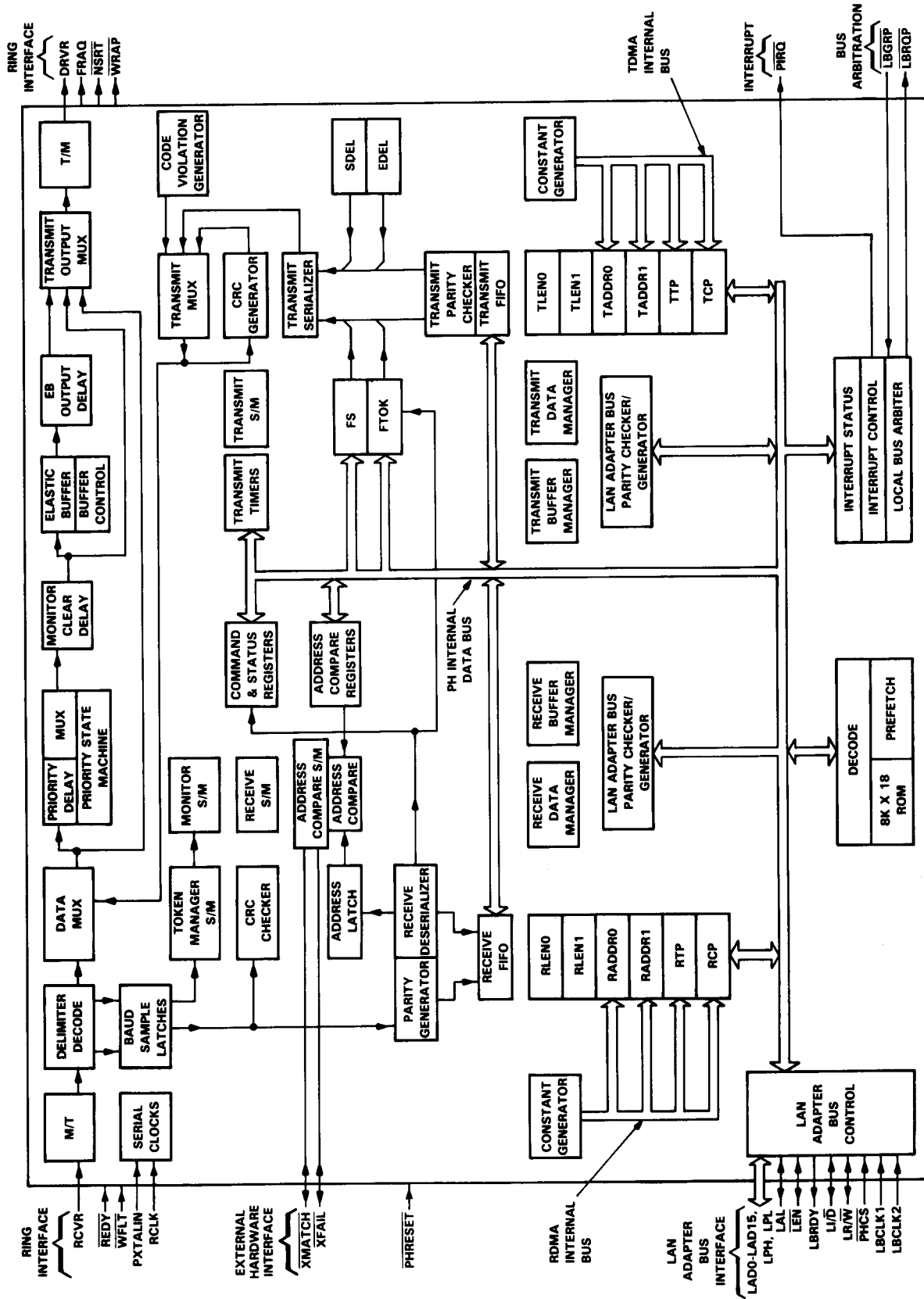

TMS38021 PROTOCOL HANDLER

description

The TMS38021 Protocol Handler integrates onto a single chip the hardware-based protocol functions for a 4 megabit per second token ring Local Area Network (LAN). An on-chip ROM contains 16K bytes of software used by the TMS38010 Communications Processor for implementation of a complete token ring Adapter function. The TMS38021 provides Differential Manchester encoding and decoding, frame address recognition, and includes state machine functions which capture free tokens, transmit and receive frames, manage the Adapter RAM buffers and provide token transmit and priority controls. Four DMA channels, two for transmit and two for receive, insure high-speed transfer of frames between the Adapter's buffer RAM and the ring. Integrity of transmitted and received data is provided by CRC generation and checking, detection of Differential Manchester code violations, and parity on internal data paths and at the LAN Adapter bus interface.

The TMS38021 is pin-compatible with the TMS38020. The TMS38021 defines two pins which were not used on the TMS38020, the \overline{XMATCH} (pin 40) and \overline{XFAIL} (pin 42) pins. These pins allow user-defined external hardware to be implemented which can provide a frame copy/frame not copy decision on all receive frames in parallel with the normal address compare capabilities of the TMS38021. Using these pins, the designer can implement extensions to the normal address recognition capability of the TMS38021 for such applications as source routing bridges.

The TMS38021 also differs from the TMS38020 in that both universal and local ring station specific addresses are supported. Thus, bit 1 of byte 0 of the specific address register high (SAH) may be set to either a one or a zero.

The TMS38021, when coupled with the TMS38010 Communications Processor, the TMS38030 System Interface, and the TMS38051 and TMS38052 Ring Interface chips, forms a highly integrated token ring LAN Adapter.

architecture

The TMS38021 Protocol Handler contains a bus master interface to the LAN Adapter bus for transfer of frame data between itself and LAN Adapter bus memory, a bus slave interface to the LAN Adapter bus for control by an external CPU, an interface to the Ring Interface circuit, and a 16K-byte ROM. Internal to the TMS38021 are several finite-state machine-implemented functions which provide bit-and frame-level processing of token protocols as well as control the flow of DMA data to and from buffer RAM resident on the LAN Adapter bus. The following paragraphs describe the blocks shown in the functional block diagram.

address compare state machine

The address compare state machine controls the recognition of addresses in a received frame (including stripped frames). In addition to normal frame address recognition capabilities, the TMS38021 provides an External Copy Hardware Option (ECHO) interface which provides a medium for the TMS38021 to signal to external hardware the presence of receive data on the LAN Adapter bus, and for external hardware to signal the results of its data check, selecting to copy or not to copy the frame. The External Copy Hardware Option (ECHO) interface is implemented via two pins on the TMS38021: the \overline{XMATCH} pin and the \overline{XFAIL} pin. The electrical and switching characteristics of these pins are described in the electrical specifications. A description of the ECHO Interface may be found below. A description of frame addressing methodology may be found in the Communications Services section of the User's Guide.

external copy hardware option (ECHO)

The external copy hardware interface consists of the \overline{XMATCH} and \overline{XFAIL} pins and makes use of the recoverable buffering technique used by the TMS38021. The TMS38021 writes a frame to memory while it is checking the address of the frame, and then recovers the buffer if the frame is not to be copied. Thus, the frame data is available to external hardware on the LAN Adapter bus for capture and examination.

In order to let the external hardware know which bus cycles carry data, the TMS38021 indicates the first data transfer of a frame. Following cycles are "traced" in the manner described below. The "pass," "fail," and "first-data" signals share the same two TMS38021 pins.

The first data transfer of a frame (AC/FC bytes) is indicated to the external logic by both the \overline{XMATCH} and \overline{XFAIL} pins being driven low by the TMS38021 (see Table 1). The external hardware must latch the address of this transfer so that succeeding receive DMA cycles may be traced. Data is stored sequentially into memory, so incrementing this latched address gives the address of the next data write. By comparing this new address to the address/data bus, the transfer of the next word of the frame can be recognized. The latch is incremented again, and the process continues until completion of the external check.

Until both the internal address check and some indication from the external hardware is received, the TMS38021 does not know whether to accept or reject the frame. It cannot assume that the external hardware timing is the same as its own. So the TMS38021 must buffer data until explicitly signalled that the external check has been completed. This is indicated by either the \overline{XMATCH} or \overline{XFAIL} pin being driven low by external hardware to indicate that the frame should be copied or not be copied respectively. The TMS38021 will not chain past the first buffer it is given. Therefore, the external hardware must give some indication at least four bytes before the end of the first buffer.

TABLE 1. \overline{XMATCH} , \overline{XFAIL} PIN FUNCTIONS

\overline{XMATCH}	\overline{XFAIL}	FUNCTION
Hi	Hi	Default state of the interface
Lo	Lo	Asserted by TMS38021 to indicate start of frame and that the AC/FC word of the frame will be transferred on this bus cycle.
Lo	Hi	Asserted by the external hardware to indicate it has completed its frame check and that the frame should be copied.
Hi	Lo	Asserted by the external hardware to indicate it has completed its frame check and the check failed.

Figure 1 illustrates the TMS38021 connection to external hardware. The interface consists of two wire-AND signal lines \overline{XMATCH} and \overline{XFAIL} . External pullups are required as these signals are only driven low.

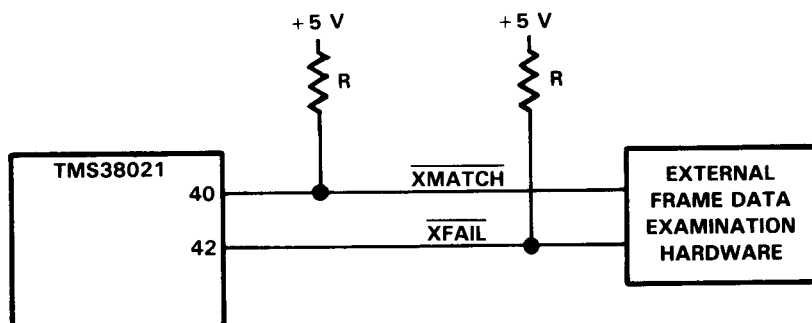

NOTE: Recommended value for R is 2.3 k Ω .

FIGURE 1. EXTERNAL COPY HARDWARE INTERFACE

TMS38021 PROTOCOL HANDLER

As the buffer recovery decision is delayed until both the internal address checker and the external hardware check are complete, the external hardware must finish its check in time to allow the buffer to be recovered. Therefore, the result of an external check should be posted by the time of the transfer of the frame word which is two words before the end of the frame.

The TMS38021 has internal pulldowns on \overline{XMATCH} and \overline{XFAIL} . However, the \overline{XFAIL} indication takes precedence over the \overline{XMATCH} indication. Thus, if no external hardware is present, the TMS38021 will copy frames based only upon its internal address compare. This allows the TMS38021 to plug into existing TMS38020 sockets.

Externally matched frames will not be copied when the ROPT bits of the RINGCMD1 register are set to "COPY ONLY EXPRESS BUFFERS". The ARI bits will be set however if a external match is indicated.

Under normal adapter operation there may be times when the TMS38021 has no buffer available for copying a frame, so data cannot be written to memory, and its transfer monitored by the external hardware. Therefore, data must be given directly to the external hardware so that the Address Recognized bits (ARI) of the frame can be correctly set.

The TMS38021 does this by writing frame data to address >0200 on the LAN Adapter bus whenever there is no buffer available. Data will be written to >0200 until the external hardware checker signals its results.

CRC checker

This block contains a 32-bit feedback shift register for calculation of the cyclic redundancy code of frames received. The TMS38021 calculates the CRC for each frame that the TMS38021 receives. If the calculated CRC does not agree with the CRC value of the received frame, the TMS38021 sets an error indicator bit within the frame to flag the occurrence of the error. If the TMS38021 was copying the frame at the time the CRC error was detected (due to an address match), the TMS38021 notifies the LAN Adapter CPU of the error. Mathematically, the CRC is calculated by considering the checked bytes as a polynomial and dividing it modulo 2 by the following polynomial:

$$G(X) = X^{32} + X^{26} + X^{23} + X^{22} + X^{16} + X^{12} + X^{11} + X^{10} + X^8 + X^7 + X^5 + X^4 + X^2 + X^1 + 1$$

CRC generator

The cyclic redundancy code (CRC) generator generates the CRC field to be inserted by the TMS38021 when transmitting. The procedure for generating CRC is identical to that described for the CRC checker.

data multiplexer

The data multiplexer selects the source of the data to be transmitted. The source may be received ring data (repeat mode), a constant of zeros (idles), or data to be transmitted by the TMS38021.

delimiter decode

This block detects the Start Delimiter (SDEL) and End Delimiter (EDEL) sequences defined for the protocol.

elastic buffer

The elastic buffer absorbs the accumulated phase jitter in the ring. During normal operation, only one station (the Active Monitor) inserts its elastic buffer on the ring. As the accumulated phase delay around the ring varies, it is "absorbed" by the elastic buffer. The elastic buffer can absorb ± 3 bits of accumulated jitter.

The total delay through the elastic buffer is 3 ± 3 bits. When the elastic buffer is not inserted on the ring, it permits the TMS38021 to detect when the incoming data frequency falls outside acceptable bounds by detecting overrun and underrun conditions.

The overrun and underrun conditions are defined to occur within a specific number of bit times. To minimize the possibility of overrun and underrun over longer periods of time, the PH re-initializes the elastic buffer every 512 bit times when in standby monitor mode and whenever the PH detects a token when in active monitor mode.

fire token register (FTOK)

The fire token register is used to hold the access control (AC) field that will be used in transmitting a token on the ring.

interrupt status logic

The interrupt status logic contains a register with information concerning TMS38021 interrupts. This logic provides interrupt vectoring, masking, and prioritization.

LAN Adapter bus parity checker

The LAN Adapter bus parity checker checks all data placed on the internal TMS38021 data bus from the LAN Adapter bus. This includes data written to the TMS38021 by an external bus master, data read by the TMS38021 receive or transmit buffer manager, and data read by the TMS38021 transmit DMA unit for transmission on the ring.

LAN Adapter bus parity generator

The parity generator generates the parity to be placed on the LAN Adapter bus when any TMS38021 register is read by an external bus master. However, received data which has parity generated by the serial parity generator has no parity generated by the bus parity generator.

manchester-to-transitional decoder (M/T)

This functional block converts the Differential Manchester code received from the ring into an internal format called "transitional" code. Transitional code is so named because baud[†] are encoded based upon their transition from the previous baud. The receive data sampled on pin RCVR is sampled by the recovered data clock input on pin RCLK.

monitor delay

The token ring protocol calls for a ring function called an Active Monitor. Each ring will have one Active Monitor which is chosen during a contention process. One function of an Active Monitor is to introduce enough delay in a ring to provide a minimum length ring sufficient to circulate a free token. When the TMS38021 is configured as an Active Monitor [the CXMT bit of the Ring Command 1 (RINGCMD1) register is set], it inserts additional monitor delay to meet the effective ring length requirement. The monitor delay consists of a 7.5-baud (half-bit times) delay preceding the elastic buffer and a 22.5-baud delay succeeding it. The total delay through the TMS38021 when the Active Monitor mode is selected is 4-baud normal delay plus 19-baud for the priority delay plus 30-baud for the monitor delay plus 6-baud average elastic buffer delay. This delay totals 59 ± 6 baud.

monitor state machine

The monitor state machine controls the setting of the Monitor Count bit of busy or priority tokens which are repeated on the ring and the detection of token activity on the ring. This state machine is active when the TMS38021 is configured as an Active Monitor [MON bit of Ring Command 1 Register (RINGCMD1) is set].

[†]Two baud equals one bit of Differential Manchester encoding.

priority delay and state machine

The TMS38021 provides control of seven levels of token priority. The priority state machine is responsible for controlling the token priority as defined by the protocol. The priority delay of 19 half-bit times is inserted when a station releases a token to allow the station to modify the token according to the priority protocol.

receive buffer manager

The receive buffer manager controls the receive buffer chaining operations on the LAN Adapter bus.

receive data manager

The receive data manager requests and acknowledges LAN Adapter bus cycles for DMA to write the received frame into memory on the LAN Adapter bus.

receive deserializer

The receive deserializer block is a 16-bit serial-in parallel-out shift register. The input is the sampled data from the ring. A serial parity generator unit calculates the parity for each eight bits shifted in and stores this parity with the parallel data. The 18 bits of data and parity are then loaded in parallel into the receive FIFO buffer.

receive DMA registers

The receive DMA registers are indicated in the functional block diagram by the names RCP, RTP, RADDR0, RADDR1, RLEN0, and RLEN1. These registers are managed by the receive buffer manager. Only the register RCP (receive chain pointer) may be accessed by external LAN Adapter bus masters. The remaining registers are not accessible by external bus masters. A brief description of these registers follows.

receive chain pointer (RCP)

This register contains the address of the buffer currently being filled with data from the ring.

receive temporary pointer (RTP)

The receive temporary pointer register contains the starting address of the buffer into which the receive DMA channel will store data when the buffer being used is full.

channel address registers (RADDR0, RADDR1)

The TMS38021 maintains two DMA channels for receive operations. The channel address register for both receive DMA channels contains the LAN Adapter bus address of the word being accessed by that channel.

channel length registers (RLEN0, RLEN1)

The channel length register for each of the two receive DMA channels contains the number of empty bytes left in the buffer currently being filled by that channel.

receive FIFO

The receive first-in, first-out (FIFO) buffer stores up to two words (16 bits) of deserialized data before it is transferred via DMA onto the LAN Adapter bus. Data is transferred onto the LAN Adapter bus under control of the receive data manager block.

serial receive state machine

This state machine controls operation of the receiver portion of the serial data path.

serial transmit state machine

This state machine controls the operation of the serial transmit data path.

transitional-to-manchester decoder (T/M)

This functional block converts the internal transitional code representation of transmit data to Differential Manchester code.

transmit buffer manager

The transmit buffer manager performs the automatic buffer changing of transmit buffers contained in LAN Adapter bus memory.

transmit data manager

The transmit data manager requests and acknowledges LAN Adapter bus cycles for DMA to read data to be transmitted on the ring.

transmit DMA registers

The transmit DMA registers (TCP, TTP, TADDR0, TADDR1, TLEN0, and TLEN1) are managed by the transmit buffer manager. Of these, only the transmit chain pointer (TCP) may be loaded by external LAN Adapter bus masters. The remaining registers are not accessible by external bus masters. The transmit DMA registers are described briefly below.

transmit chain pointer (TCP)

The transmit chain pointer contains the address of the buffer currently being read for transmit data.

transmit temporary pointer (TTP)

The transmit temporary pointer register contains the starting address of the buffer from which transmit data will be read by the DMA channel when the present buffer had been read.

channel address registers (TADDR0, TADDR1)

The TMS38021 maintains two DMA channels for transmit operations. The channel address register for both transmit DMA channels contains the LAN Adapter bus address of the word being read by that channel.

channel length registers (TLEN0, TLEN1)

The channel length register for each of the two transmit DMA channels contains the number of bytes yet to be transmitted from the current buffer.

transmit FIFO

The transmit FIFO buffers two 16-bit words, allowing the TMS38021 to maintain a constant flow of transmitted data into the transmit serializer. The parity from the LAN Adapter bus is maintained within the FIFO.

transmit multiplexer

The transmit multiplexer selects either the CRC generator or transmit serializer output onto the transmit data path.

transmit parity checker

The transmit parity checker checks the parity of data transferred from the top of the transmit FIFO to the transmit serializer. It performs the final check of data before it is placed in the serializer.

transmit serializer

The transmit serializer is a 16-bit parallel-in, serial-out shift register. The shift register is loaded from the data at the top of the transmit FIFO, from the concatenation of the Start Delimiter (SDEL) and the fire token register (FTOK) or from a concatenation of the End Delimiter (EDEL) and the frame status (FS) register.

TMS38021 PROTOCOL HANDLER

transmit timer

The TMS38021 contains a physical trailer timer (PTT). This timer provides a watchdog timer function for halting the frame strip process after transmitting a frame.

command and status registers

The command and status registers of the TMS38021 are registers which may be read/written through memory-mapped I/O by an external bus master on the LAN Adapter bus. These registers are mapped to LAN Adapter bus addresses as shown in Figure 2.

ADDRESS	BITS		DESCRIPTION
	0 7	8 15	
>0100	RINGCMD0		RING COMMAND 0
>0102	RINGCMD1		RING COMMAND 1
>0104	RINGSTS		RING STATUS
>0106	INTSTAT		INTERRUPT STATUS
>0108	00 [†]	PTTLATCH	PHYSICAL TRAILER TIMER LATCH
>010A	RCP		RECEIVE CHAIN POINTER
>010C	TCP		TRANSMIT CHAIN POINTER
>010E	FTOK	00 [‡]	FIRE TOKEN

[†]Most-significant bits are reserved.

[‡]Least-significant bits are reserved.

FIGURE 2. TMS38021 COMMAND AND STATUS REGISTERS

ring command 0 (RINGCMD0)

The RINGCMD0 register enables specific receive and transmit modes of the TMS38021 including idle insertion between frames and stripping of transmitted data from the ring. The bits of RINGCMD0 are defined in Table 2.

TABLE 2. RING COMMAND 0 (RINGCMD0) REGISTER BIT FUNCTIONS

BIT	NAME	DESCRIPTION
0	XMTIMM	Transmit Immediate Mode
1	BDM	Baud Data Mode
2	NOSTRIP	No Strip Mode
3	XMTCRC	Transmit CRC
4	RNFT	Release No Free Token
5	XMTIDLE	Transmit Idles Mode
6	ETO	Enable Transmitter Output
7	PTEST	Parity Test
8	GAP0	Interframe Gap Bit 0
9	GAP1	Interframe Gap Bit 1
10	GAP2	Interframe Gap Bit 2
11		Reserved. This bit must be zero.
12		Reserved. This bit must be zero.
13		Reserved. This bit must be zero.
14		Reserved. This bit must be zero.
15	NOCHAIN	No Receive Chaining

ring command 1 (RINGCMD1)

The RINGCMD1 register is the master control register of the TMS38021. This register controls such functions as reset, clock sourcing, ring insertion, and address recognition. The bits of RINGCMD1 are defined in Table 3. The functions of receive options, ROPT0 and ROPT1, are presented in Table 4.

TABLE 3. RING COMMAND 1 (RINGCMD1) REGISTER BIT FUNCTIONS

BIT	NAME	DESCRIPTION
0	NRESET	Not Reset
1	NFRAQ	Not Frequency Acquisition
2	INSERT	Insert Into Ring
3	NWRAP	Not Internal Wrap
4	CXMT	Crystal Transmit Mode Select
5	MON	Active Monitor Mode Select
6		Reserved. This bit must be set to zero.
7		Reserved. This bit must be set to one.
8		Reserved. This bit must be set to zero.
9	IGN0	Ignore Control 0
10	IGN1	Ignore Control 1
11	IGN2	Ignore Control 2
12	IGN3	Ignore Control 3
13	ROPT0	Receive Option 0
14	ROPT1	Receive Option 1
15		Reserved.

TABLE 4. RECEIVE OPTION BIT DECODE

ROPT0	ROPT1	DESCRIPTION
0	0	Normal frame recognition
0	1	Copy only express buffer MAC frames.
1	1	Line Monitor Mode. (Externally matched frames are copied, but ARI/FCI are not set.)
1	0	Copy all frames

ring status register (RINGSTS)

The RINGSTS register provides general ring status information, including ring interface status, error logging, and token validation. The bits of RINGSTS are defined in Table 5.

TABLE 5. RING STATUS (RINGSTS) REGISTER BIT FUNCTIONS

BIT	NAME	DESCRIPTION
0	NGO	Not Go (Signal Loss)
1	GTDET	Good Token Detect
2	ATDET	Any Token Detect
3	WFAULT	Wire Fault
4	EBOUF	Elastic Buffer Over/Under Flow
5-9		Reserved
10	MAC0	MAC Attention Code Bit 0
11	MAC1	MAC Attention Code Bit 1
12	MAC2	MAC Attention Code Bit 2
13	MAC3	MAC Attention Code Bit 3
14	RIDER0	FS Rider Control Bit 0
15	RIDER1	FS Rider Control Bit 2

interrupt status (INSTAT)

The INSTAT register contains information concerning TMS38021 interrupts. This register provides interrupt vectoring, masking, and prioritization. The bits of INSTAT are defined in Table 6. Table 7 lists the decode for bits 11 through 14 (INTCODE0 through INTCODE3).

TABLE 6. INTERRUPT STATUS (INTSTAT) REGISTER BIT FUNCTIONS

BIT	NAME	DESCRIPTION
0	MIE	Master Interrupt Enable
1		Reserved
2	EORBE	End of Receive Buffer Interrupt Enable
3	EOTBE	End of Transmit Buffer Interrupt Enable
4	SLIE	Signal Loss Interrupt Enable
5-7		Reserved
8	ID0	Interrupt Source ID Bit 0
9	ID1	Interrupt Source ID Bit 1
10	ID2	Interrupt Source ID Bit 2
11	INTCODE0	Interrupt Code Bit 0
12	INTCODE1	Interrupt Code Bit 1
13	INTCODE2	Interrupt Code Bit 2
14	INTCODE3	Interrupt Code Bit 3
15	"0"	Always zero

TABLE 7. INTERRUPT CODE 0 (INTCODE0) THROUGH INTERRUPT CODE 3 (INTCODE3) DECODE

INTCODE0	INTCODE1	INTCODE2	INTCODE3	DEFINITION
0	0	0	0	Reserved
0	0	0	1	LAN Adapter Bus Parity Error
0	0	1	0	Token Error
0	0	1	1	Signal Loss
0	1	0	0	BURST5 Error in Frame
0	1	0	1	Log Error
0	1	1	0	No Buffer Available
0	1	1	1	Attention
1	0	0	0	Reserved
1	0	0	1	Receive Frame Error
1	0	1	0	Transmit Frame Error
1	0	1	1	Receive End of Buffer
1	1	0	0	Transmit End of Buffer
1	1	0	1	Receive End of Frame
1	1	1	0	Transmit End of Frame
1	1	1	1	No Interrupt Pending

physical trailer timer latch (PTTLATCH)

The PTTLATCH register is an 8-bit control register containing a ring-speed-specific time constant. This value is the starting value of a timer which is started following the transmission of a frame so that a lost frame condition may be detected.

receive chain pointer (RCP)

The RCP register contains the starting address of the buffer into which the receive DMA channel, if active, stores receive data.

transmit chain pointer (TCP)

The TCP register contains the starting address of the buffer into which the transmit DMA channel, if active, reads data for transmission.

fire free token register (FTOK)

The FTOK register is used to hold the Access Control Field (AC) to be included in a token that will be generated by the TMS38021 and transmitted on the ring. Writing to the FTOK register causes a token to be released.

address compare registers

The TMS38021 contains 15 registers for use in comparing frame addresses. These registers are shown with their corresponding LAN Adapter bus addresses in Figure 3.

ADDRESS	NAME	DESCRIPTION
>0110	SAH	SPECIFIC ADDRESS BITS 0-15
>0112	SAM	SPECIFIC ADDRESS BITS 16-31
>0114	SAL	SPECIFIC ADDRESS BITS 32-47
>0116		RESERVED. ALWAYS READ AS ZERO
>0118	STRIPHI	STRIP ADDRESS BITS 16-31
>011A	STRIPLO	STRIP ADDRESS BITS 32-47
>011C	GNAM1	GROUP ADDRESS BITS 16-31
>011E	GNAL	GROUP ADDRESS BITS 32-47
>0120	GNAH	GROUP ADDRESS BITS 0-15
>0122	>0000	RESERVED
>0124	>0000	RESERVED
>0126	>0000	RESERVED
>0128	>0000	RESERVED
>012A	>0000	RESERVED
>012C	FNAHI	FUNCTIONAL ADDRESS BITS 0-15
>012E	FNALO	FUNCTIONAL ADDRESS BITS 16-31

FIGURE 3. ADDRESS COMPARE REGISTERS

buffer management

The TMS38021's buffer managers move frame data in and out of buffer RAM, located on the LAN Adapter bus, through one or more singly-linked buffers. These buffers are aligned on 8-byte boundaries and have the organization for transmit and receive as shown in Figure 4.

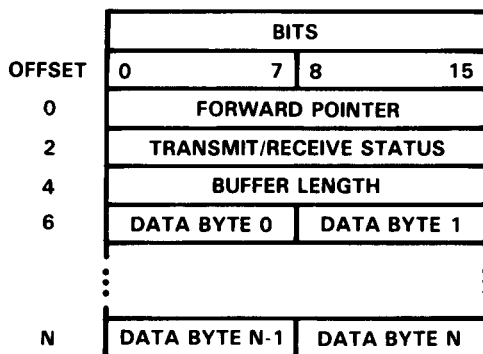

FIGURE 4. BUFFER ORGANIZATION

The forward pointer contains the address of the next buffer in a chain. The transmit/receive status field is used to report frame status. The length field contains the number of bytes in the data field of the buffer. This field is initialized by the LAN Adapter bus CPU.

transmit buffers

When the buffer organization shown in Figure 4 is used for transmit frames, the status field has the bit functions shown in Table 8 in the last buffer in a chain used to transmit the frame.

TABLE 8. TRANSMIT STATUS FIELD BIT FUNCTIONS

BIT	NAME	FUNCTION
0	INUSE	In Use Indicator
1	LFED	Local Frame Error Detect
2	RTEDI	Returned Error Detected Indicator
3	TCC0	Transmit Completion Code Bit 0
4	TCC1	Transmit Completion Code Bit 1
5	TCC2	Transmit Completion Code Bit 2
6	TCC3	Transmit Completion Code Bit 3
7	EOF	End Of Frame Indicator
8	FS0	Stripped Frame Status Bit 0 (ARI)
9	FS1	Stripped Frame Status Bit 1 (FCI)
10	FS2	Stripped Frame Status Bit 2
11	FS3	Stripped Frame Status Bit 3
12	FS4	Stripped Frame Status Bit 4 (ARI)
13	FS5	Stripped Frame Status Bit 5 (FCI)
14		Reserved. This bit is zero.
15		Reserved. This bit is zero.

The decode function of the transmit completion code bits (TCC) is presented in Table 9.

TABLE 9. TRANSMIT COMPLETION CODE (TCC) BIT DECODE

PARALLEL LAN ADAPTER BUS PATH

TCC0	TCC1	DESCRIPTION
0	0	Normal
0	1	Parity Error
1	0	DMA Underrun
1	1	Next Buffer Unavailable

SERIAL RING DATA PATH

TCC2	TCC3	DESCRIPTION
0	0	Normal Completion
0	1	PTT Timeout
1	0	Invalid Free Token
1	1	Invalid Abort on Strip

For frames to be transmitted on the ring, the data portion of a transmit buffer has the format shown in Figure 5.

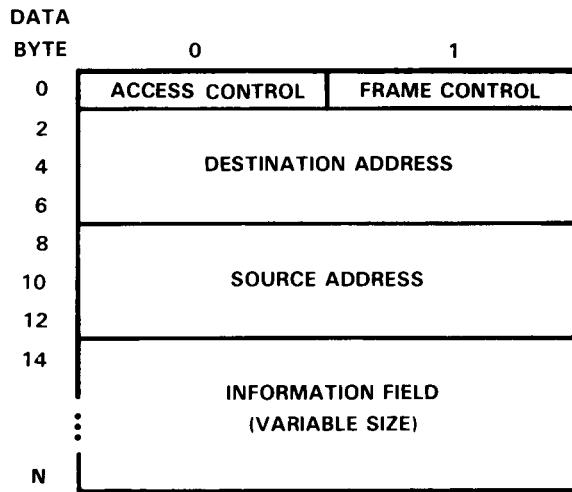

FIGURE 5. TRANSMIT DATA FORMAT

receive buffers

When the buffer organization shown in Figure 4 is used for receive frames, the status field has the bit functions shown in Table 10 in the last buffer in a chain used to receive the frame.

TABLE 10. RECEIVE STATUS FIELD BIT FUNCTIONS

BIT	NAME	FUNCTION
0	INUSE	In Use
1	LFED	Local Frame Error Detect
2	REDI	Receive Error Detect Indicator
3	RCC0	Receive Completion Code Bit 0
4	RCC1	Receive Completion Code Bit 1
5	RCC2	Receive Completion Code Bit 2
6	RCC3	Receive Completion Code Bit 3
7	EOF	End of Frame Indicator
8	FS0	Receive Frame Status Bit 0
9	FS1	Receive Frame Status Bit 1
10	FS2	Receive Frame Status Bit 2
11	FS3	Receive Frame Status Bit 3
12	FS4	Receive Frame Status Bit 4
13	FS5	Receive Frame Status Bit 5
14		Reserved
15		Reserved

The decoded function of the receive completion code bits (RCC) is presented in Table 11.

TABLE 11. RECEIVE COMPLETION CODE (RCC) BIT DECODE

PARALLEL LAN ADAPTER BUS PATH			SERIAL RING DATA PATH		
RCC0	RCC1	DESCRIPTION	RCC2	RCC3	DESCRIPTION
0	0	Normal Completion	0	0	Normal Completion
0	1	Parity Error	0	1	Error: FCI not set
1	0	DMA Overrun	1	0	Implicit Abort
1	1	Next Buffer Unavailable	1	1	Explicit Abort

For frames received from the ring, the data portion of a receive buffer has the format shown in Figure 6.

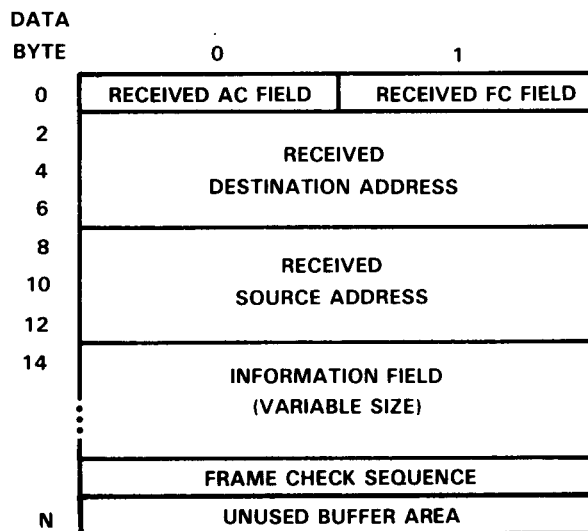

FIGURE 6. RECEIVE DATA FORMAT

TMS38021 PROTOCOL HANDLER

TMS38021 ROM

The TMS38021 contains a 16K-byte ROM organized as 8K x 18 bits. Each byte contains an odd parity bit. The ROM is not used by internal TMS38021 logic but is accessed by the LAN Adapter bus CPU for program storage. This ROM contains object code for the TMS38010 Communications Processor. This ROM contains software which provides media access protocols compatible with IEEE Std 802.5-1985, protocol services for network management servers, and diagnostics which verify proper functionality of the TMS380 Token Ring Adapter.

Access to this ROM from the TMS38010 Communications Processor is in one or two LAN Adapter bus read cycles. A prefetch unit reads the word sequentially following the last word read so that sequential accesses occur with no wait states forced on the TMS38010. When access is nonsequential, the TMS38021 deasserts LBRDY in the first cycle to force the CPU to accept a wait state. On the second cycle, the TMS38021 asserts LBRDY and places the ROM data on the bus.

When the TMS38021 is a bus slave, it will also respond if external circuitry deasserts LBRDY; it will continuously drive its output data (on reads) or delay modifying its internal register (on writes) until LBRDY is asserted high.

address decoding

The TMS38021 performs decoding of LAN Adapter bus addresses as shown in Table 13. Note that not all addresses are strictly decoded. For example, the TMS38021 does not decode address line A1 for ROM accesses at >C000. Thus, a memory read at address location >8000 is identical to an address read at location >C000. For this reason, expansion RAM on the LAN Adapter bus should negate PHCS whenever expansion RAM overlays memory addresses >8000 through >BFFF.

TABLE 13. TMS38021 ADDRESS DECODING

PHCS	A0	A1	A2	A3	A4	A5	A6	A7	A8	A9	A10	A11	A12	A13	A14	SELECTED TMS38021 LOCATION
H	X	X	X	X	X	X	X	X	X	X	X	X	X	X	X	TMS38021 not selected
L	L	L	L	L	L	L	L	L	X	X	X	X	X	X	X	TMS38021 not selected
L	L	L	L	L	L	L	L	L	H	X	X	L	L	Int'l Decode		Command/Status Registers
L	L	L	L	L	L	L	L	L	H	X	X	L	H	Int'l Decode		Address Compare Registers
L	L	L	L	L	L	L	L	L	H	X	X	H	L	Int'l Decode		Compare Address Registers
L	L	L	L	L	L	L	L	L	H	X	X	H	H	Int'l Decode		Internal Test Registers
L	L	X	X	X	X	X	H	X	X	X	X	X	X	X	X	TMS38021 not selected
L	L	X	X	X	X	H	X	X	X	X	X	X	X	X	X	TMS38021 not selected
L	L	X	X	X	H	X	X	X	X	X	X	X	X	X	X	TMS38021 not selected
L	L	X	X	H	X	X	X	X	X	X	X	X	X	X	X	TMS38021 not selected
L	L	X	H	X	X	X	X	X	X	X	X	X	X	X	X	TMS38021 not selected
L	L	H	X	X	X	X	X	X	X	X	X	X	X	X	X	TMS38021 not selected
L	H	X	← Internal Decode →													TMS38021 ROM

test mode

The TMS38021 features a module-in-place test mode for board-level testing with the TMS38021 in-circuit. This facilitates testing by bed-of-nails testers. This test mode is enabled by tying the PHTEST pin (pin 41) to ground. This has the effect of driving all outputs of the TMS38021 to a high-impedance state. When not used for testing purposes, this pin should be left unconnected. An internal pullup drives this pin high when not externally connected.

absolute maximum ratings over operating free-air temperature range (unless otherwise noted)†

Supply voltage, V_{CC} (see Note 1)	7 V
Input voltage range	-0.3 V to 20 V
Output voltage range	-2 V to 7 V
Operating free-air temperature range (see Note 2)	0°C to 70°C
Storage temperature range	-65°C to 150°C

†Stresses beyond those listed under "Absolute Maximum Ratings" may cause permanent damage to the device. This is a stress rating only and functional operation of the device at these or any other conditions beyond those indicated in the "Recommended Operating Conditions" section of this specification is not implied. Exposure to absolute-maximum-rated conditions for extended periods may affect device reliability.

NOTES: 1. Voltage values are with respect to V_{SS} .
2. Devices are tested in an environment in excess of 70°C to guarantee operation at 70°C. Case temperatures should be maintained at or below 80°C.

recommended operating conditions

		MIN	NOM	MAX	UNIT
V_{CC}	Supply voltage	4.5	5	5.5	V
V_{SS}	Supply voltage (Note 3)	0			V
V_{IH}	High-level input voltage	LBCLK1, LBCLK2		3.8	V
		RCVR, RCLK		2.6	V
		PHTEST		V_{CC}	V
		All other inputs		2	V
V_{IL}	Low-level input voltage	LBCLK1, LBCLK2, RCVR, RCLK		0.6	V
		PHTEST		V_{SS}	V
		All other inputs		0.8	V
I_{OH}	High-level output current	All outputs		0.15	mA
I_{OL}	Low-level output current	DRVR		-1.2	mA
		LBRDY		-2.4	mA
		All other outputs		-1.7	mA
C_L	Load capacitance	DRVR		30	pF
		All other outputs		100	pF
T_A	Operating free-air temperature (Note 2)	0		70	°C

NOTES: 2. Devices are tested in an environment in excess of 70°C to guarantee operation at 70°C. Case temperatures should be maintained at or below 80°C.
3. Care should be taken by PC board designers to provide a minimum inductance path between the V_{SS} pins and system ground in order to minimize V_{SS} noise.

TMS38021 PROTOCOL HANDLER

electrical characteristics over full range of recommended operating conditions (unless otherwise noted)

PARAMETER		TEST CONDITIONS	MIN	TYP	MAX	UNIT
V_{OH}	High-level output voltage	All outputs $V_{CC} = 4.5\text{ V}$, $I_{OH} = 0.15\text{ mA}$	2.4			V
V_{OL}	Low-level output voltage	All outputs $V_{CC} = 4.5\text{ V}$, $I_{OL} = \text{Max}$			0.45	V
I_{OH}	High-level output current	All outputs $V_{CC} = 4.5\text{ V}$, $V_{OH} = 2.4\text{ V}$			0.15	mA
I_{OL}	Low-level output current	DRVR			-1.2	mA
		LBRDY	$V_{CC} = 4.5\text{ V}$, $V_{OL} = 0.45\text{ V}$		-2.4	mA
		All other outputs			-1.7	mA
I_{OZL}	Off-state (high-impedance state) output current with low-level voltage applied, outputs and I/O's only	$V_O = 0.45\text{ V}$			-50	μA
I_{OZH}	Off-state (high-impedance state) output current with high-level voltage applied, outputs and I/O's only	$V_O = 2.4\text{ V}$			50	μA
I_{IL}	Low-level input current	PHTEST (Note 4)			-700	μA
		All other inputs	$V_I = V_{SS}$, V_{CC} at 4.75 V - 5.25 V		-20	μA
I_{IH}	High-level input current	All other inputs except PHTEST (Note 5)			20	μA
I_{CC}	Supply current	$V_{CC} = 5\text{ V}$, $T_A = 25^\circ\text{C}$		110		μA
		$V_{CC} = 5.5\text{ V}$, $T_A = 0^\circ\text{C}$			175	μA
		$V_{CC} = 5.5\text{ V}$, $T_C = 80^\circ\text{C}$			125	μA
C_i	Input capacitance	LBCLK1, LBCLK2	$f = 1\text{ MHz}$,		20	pF
		RCVR, RCLK	all other		10	pF
		All other inputs	inputs at 0 V		15	pF

NOTES: 4. PHTEST has an internal pullup resistor implemented. It may be left unconnected; in this case it is interpreted as high.
5. I_{IH} for PHTEST is not specified because it will never be driven.

LAN ADAPTER BUS CLOCK PARAMETERS

timing requirements over recommended supply voltage range and operating free-air temperature range (see Figure 7)

		MIN	MAX	UNIT
$t_{c(LA)}$	LAN Adapter bus cycle time (Note 6)	333	333.7	ns
t_{d1}	Delay time, LBCLK2 low to LBCLK2 no longer low in next cycle	$4Q - 2$	$4Q + 2$	
t_{d2}	Delay time, LBCLK2 rise to LBCLK2 high in next cycle		$4Q + 9$	
t_{d3}	Delay time, LBCLK2 no longer low to LBCLK1 no longer low	$Q - 3$	$Q + 3$	
t_{d4}	Delay time, LBCLK2 rise to LBCLK1 high		$Q + 9$	
t_{d5}	Delay time, LBCLK2 no longer low to LBCLK2 no longer high	$2Q - 2$	$2Q + 7$	
t_{d6}	Delay time, LBCLK2 rise to LBCLK2 low		$2Q + 12$	
t_{d7}	Delay time, LBCLK2 no longer low to LBCLK1 no longer high	$3Q - 15$	$3Q - 1$	
t_{d8}	Delay time, LBCLK2 rise to LBCLK1 low		$3Q$	
t_{d9}	Delay time, LBCLK1 low to LBCLK2 high		Q	
t_{d10}	Delay time, LBCLK2 high to LBCLK1 high		$Q - 4$	
t_{d11}	Delay time, LBCLK1 high to LBCLK2 low		$Q - 4$	
t_{d12}	Delay time, LBCLK2 low to LBCLK1 low		$Q - 16$	

NOTES: 6. The LAN Adapter bus cycle time is $333.3 \text{ ns} \pm 0.1\%$. This value shall be used for calculations requiring the time between successive rising edges of LBCLK2.

7. $Q = 0.25 t_{c(LA)}$.

**TMS38021
PROTOCOL HANDLER**

LAN ADAPTER BUS READ AND WRITE PARAMETERS

timing requirements/switching characteristics over recommended supply voltage range and operating free-air temperature range (see Figure 7)†

	MIN	MAX	UNIT
t _{d13} Delay time, LBCLK2 rise to LI/ \overline{D} valid		47	ns
t _{d14} Delay time, LBCLK2 rise to LAL high		47	
t _{d15} Delay time, LBCLK2 rise to address valid		47	
t _{d16} Delay time, LBCLK2 rise to LR/ \overline{W} valid		47	
t _{WH1} Pulse duration, LAL high	Q - 50		
t _{d17} Delay time, address valid to LAL no longer high	Q - 50		
t _{d18} Delay time, LAL fall to 1.3 V to address no longer valid	7		
t _{d19} Delay time, LBCLK1 high to address no longer valid	7		
t _{d20} Delay time, LBCLK2 rise to LAD, LPH, LPL high impedance in read cycle		Q + 74	
t _{d21} Delay time, LAD, LPH, LPL high impedance to $\overline{L\!E\!N}$ no longer high in read cycle	0		
t _{d22} Delay time, LBCLK2 rise to $\overline{L\!E\!N}$ low in read cycle		Q + 84	
t _{d23} Delay time, LBCLK2 rise to $\overline{L\!E\!N}$ low in write cycle		Q + 47	
t _{d24} Delay time, LBCLK1 low to $\overline{L\!E\!N}$ no longer low in read cycle	0		
t _{d25} Delay time, LBCLK2 rise to $\overline{L\!E\!N}$ high in read cycle		3Q + 47	
t _{d26} Delay time, LBCLK2 rise to LAL low		2Q - 12	
t _{d27} Delay time, LBCLK1 low to LAD, LPH, LPL no longer high impedance in next cycle	80		
t _{d28} Delay time, LBCLK2 rise to write data valid		3Q - 70	
t _{d29} Delay time, LBCLK1 low to LI/ \overline{D} , LR/ \overline{W} no longer valid	20		
t _{d30} Delay time, LBCLK1 low to write data no longer valid	20		
t _{d31} Delay time, LBCLK1 low to $\overline{L\!E\!N}$ no longer low in write cycle	20		
t _{d32} Delay time, LBCLK1 low to $\overline{L\!E\!N}$ high in write cycle		80	
t _{d33} Delay time, LBCLK2 rise to $\overline{L\!E\!N}$ no longer high in write cycle	Q - 4		
t _{su1} Setup time, read data valid to LBCLK1 no longer high	20		
t _{h1} Hold time, read data valid after LBCLK1 low if t _{h2} not met	15		
t _{h2} Hold time, read data valid after $\overline{L\!E\!N}$ no longer low if t _{h1} not met	0		
t _{d34} Delay time, LBCLK2 rise to LBRDY high		2Q - 41	
t _{d35} Delay time, LBCLK2 rise to LBRDY low		2Q - 21	
t _{h3} Hold time, LBRDY valid after LBCLK2 low	80		

†This table is entitled switching characteristics/timing requirements because several of the parameters specified can be classified as characteristics or requirements depending on the mode of operation: bus slave or bus master (DMA). The values given are valid for both modes.

NOTE 7: Q = 0.25t_c(LA).

PARAMETER MEASUREMENT INFORMATION

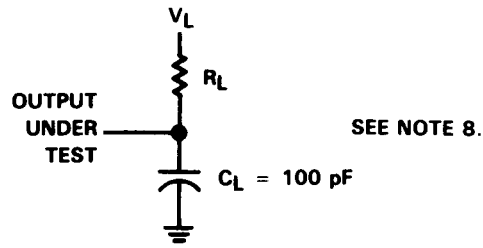

NOTE 8: R_L and V_L are chosen as follows:

$$R_L = \frac{V_{OH} - V_{OL}}{|I_{OL} - I_{OH}|} \quad V_L = V_{OH} - (I_{OH})(R_L)$$

FIGURE 7. LOAD CIRCUIT

LAN Adapter bus read timing

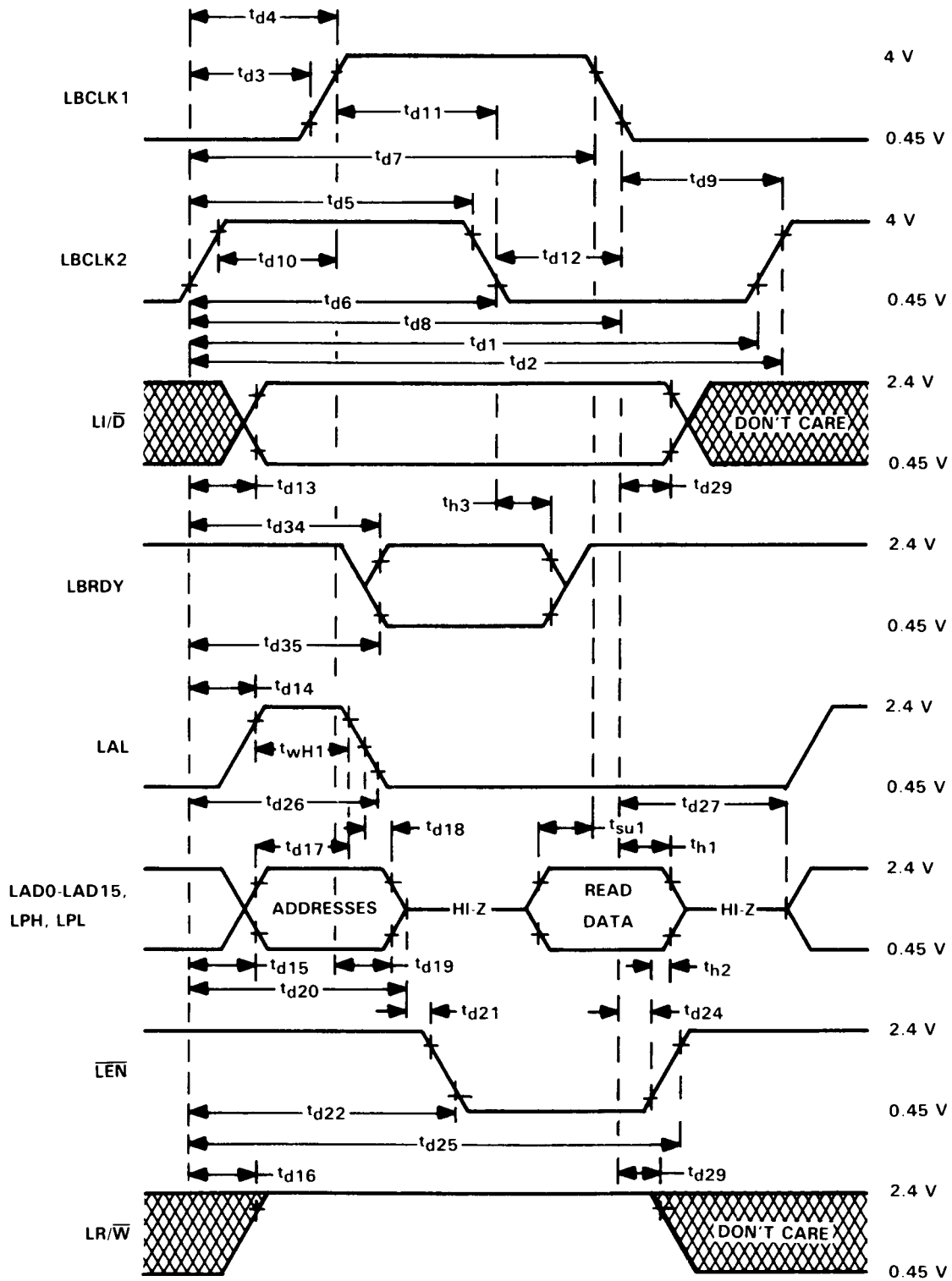

NOTE 9: The timing reference points for LBCLK1 and LBCLK2 are 3 V and 0.8 V. The timing reference points for the other waveforms are 2 V and 0.8 V. The intermediate reference point for LAL is 1.3 V.

LAN Adapter bus write timing

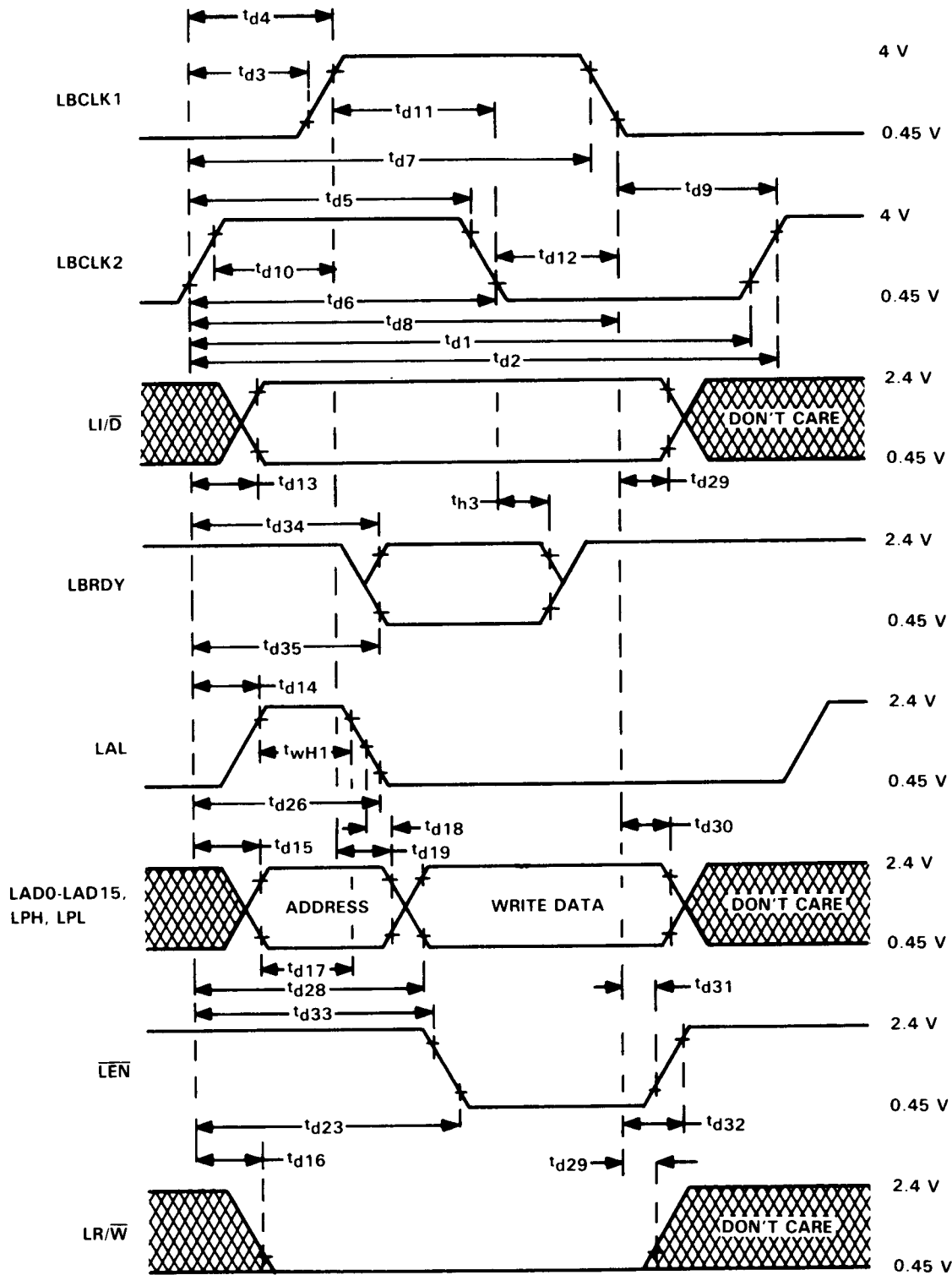

NOTE 9: The timing reference points for LBCLK1 and LBCLK2 are 3 V and 0.8 V. The timing reference points for the other waveforms are 2 V and 0.8 V. The intermediate reference point for LAL is 1.3 V.

LAN ADAPTER BUS ARBITRATION PARAMETERS

switching requirements over recommended supply voltage range and operating free-air temperature range (see Figure 7)

PARAMETER		MIN	MAX	UNIT
t _{d36}	Delay of $\overline{\text{LBRO}}\overline{\text{P}}$ from LBCLK1 low		48	ns
t _{d37}	Delay of $\overline{\text{LBRO}}\overline{\text{P}}$ after LBCLK1 high	0		
t _{d38}	Delay time, LBCLK2 rise to LAL no longer high impedance by TMS38021	2Q - 9		
t _{d39}	Delay time, LBCLK2 rise to LAL driven low by TMS38021		3Q - 15	
t _{d40}	Delay time, LBCLK1 low to $\overline{\text{LEN}}$ no longer high impedance by TMS38021	80		
t _{d41}	Delay time, LBCLK2 rise to $\overline{\text{LEN}}$ driven high by TMS38021		74	
t _{d42}	Delay time, LBCLK1 low to $\overline{\text{LR}}/\overline{\text{W}}$, $\overline{\text{LI}}/\overline{\text{D}}$, LAD0-LAD15, LPH, and LPL no longer high impedance by TMS38021	80		

NOTE 7: Q = 0.25t_{c(LA)}.

timing requirements over recommended supply voltage range and operating free-air temperature range

		MIN	MAX	UNIT
t _{d43}	Delay time, LBCLK2 rise to $\overline{\text{LBGR}}\overline{\text{P}}$ valid		2Q - 73	ns
t _{d44}	Delay time, LBCLK2 rise to $\overline{\text{LBGR}}\overline{\text{P}}$ no longer valid	-6		
t _{d45}	Delay time, LBCLK2 rise to LAL no longer driven low from old bus master	3Q - 15		
t _{d46}	Delay time, LBCLK2 rise to LAL high impedance from old bus master		4Q - 2	
t _{d47}	Delay time, LBCLK2 rise to $\overline{\text{LEN}}$ high impedance from old bus master		74	
t _{d48}	Delay time, LBCLK1 low to $\overline{\text{LR}}/\overline{\text{W}}$, $\overline{\text{LI}}/\overline{\text{D}}$, LAD0-LAD15, LPH, and LPL high impedance from old bus master		80	

NOTE 7: Q = 0.25t_{c(LA)}.

LAN Adapter bus arbitration

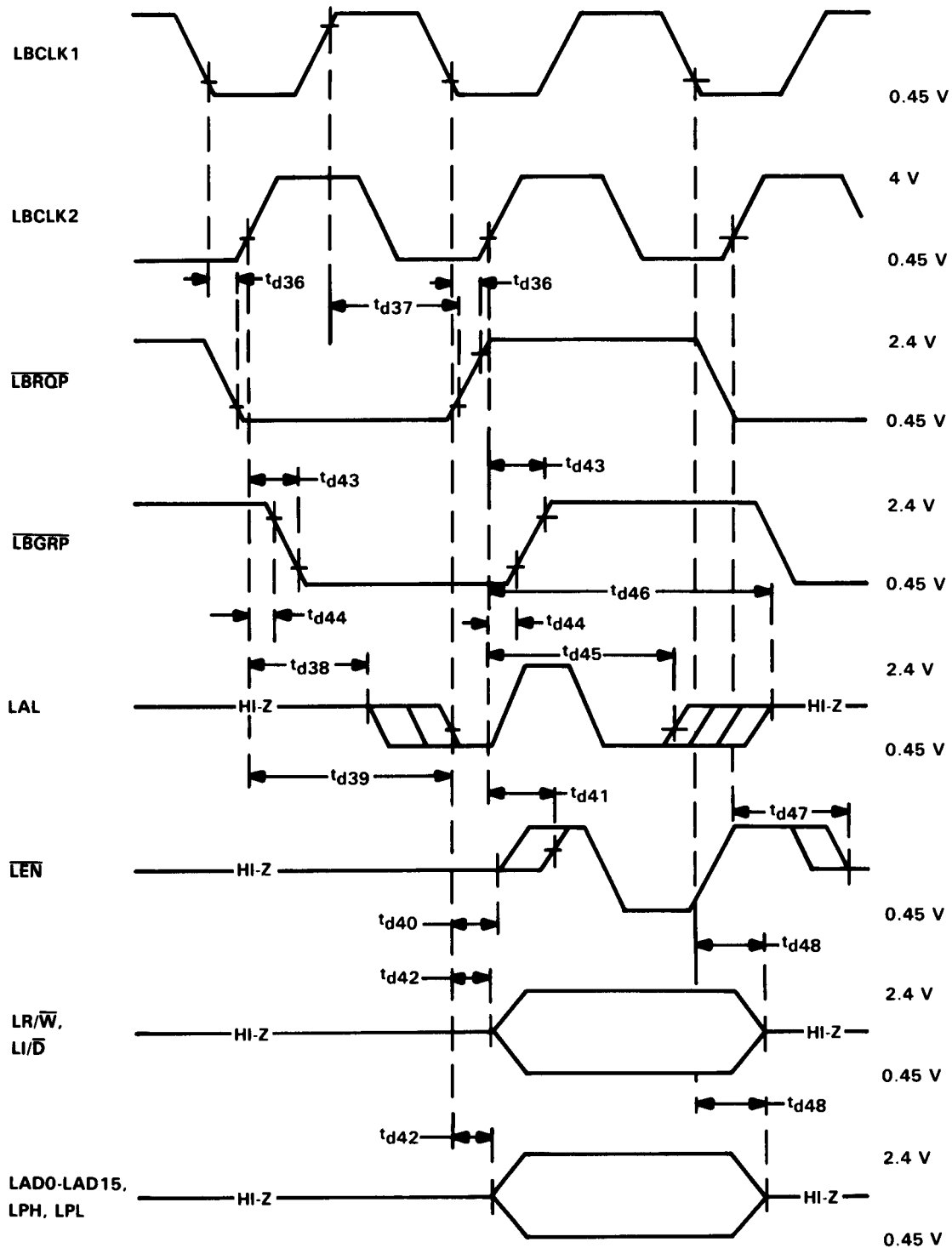

NOTE 10: The timing reference points for LBCLK1 and LBCLK2 are 3 V and 0.8 V. The timing reference points for the other waveforms are 2 V and 0.8 V.

MISCELLANEOUS LAN ADAPTER BUS PARAMETERS

timing requirements over recommended supply voltage range and operating free-air temperature range

	MIN	MAX	UNIT
t_{d49} Delay time, LBCLK1 high to \overline{PHCS} low		10	ns
t_{d50} Delay time, LBCLK2 rise to \overline{PHCS} no longer valid	0		
t_{d51} Delay time, LBCLK2 rise to LBRDY driven low in ROM prefetch miss		145	
t_{d52} Delay time, LBCLK1 low to LBRDY high impedance after ROM prefetch miss		45	
t_{d53} Delay time, LBCLK2 rise to \overline{PIRQ} valid		60	
t_{d54} Delay time, LBCLK2 rise to \overline{PIRQ} no longer valid	0		
t_{d55} Delay time, LBCLK2 rise to \overline{PHCS} high		Q - 3	

NOTE 7: Q = 0.25 $t_c(LA)$.

\overline{PHCS} and LBRDY timing

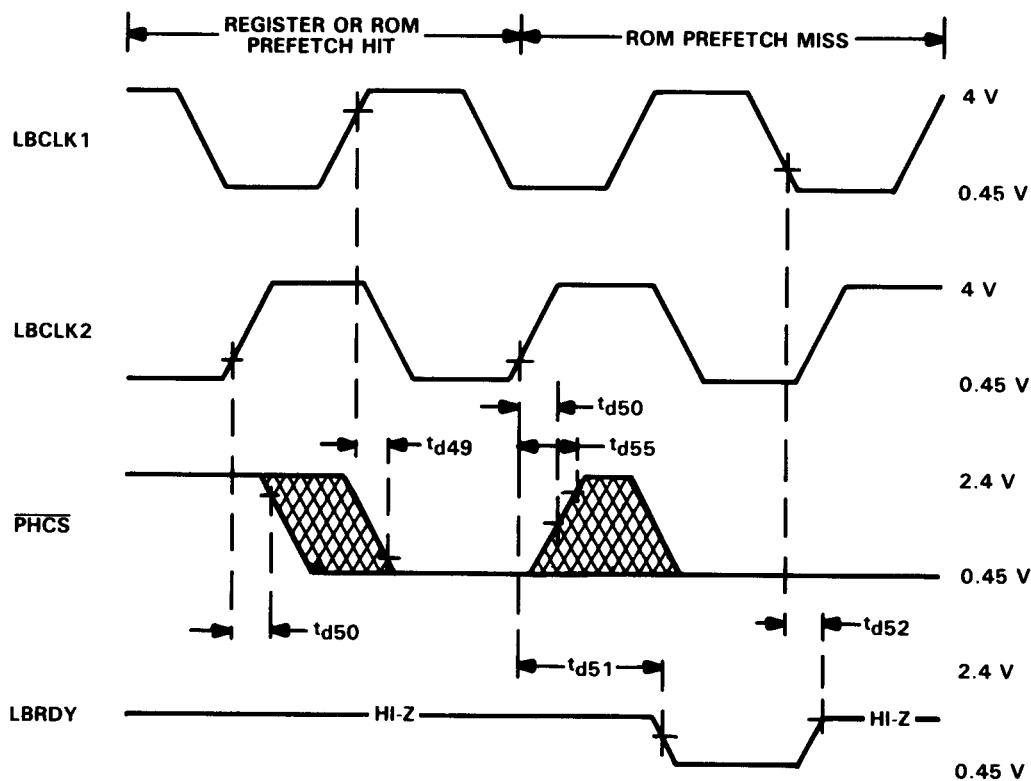

NOTE 10: The timing reference points for LBCLK1 and LBCLK2 are 3 V and 0.8 V. The timing reference points for the other waveforms are 2 V and 0.8 V.

interrupt timing

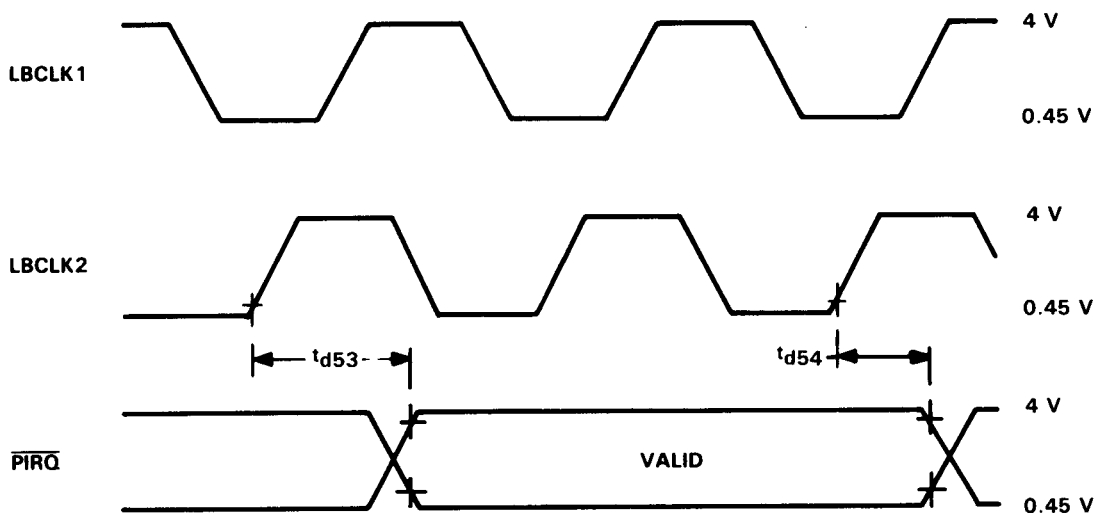

MISCELLANEOUS TIMING PARAMETERS

timing requirements over recommended supply voltage range and operating free-air temperature range

	MIN	MAX	UNIT
$t_w(LRS)$ $\overline{PHRESET}$ pulse duration, asserted with minimum V_{CC} or greater applied	14		μS
$t_r(LRS)$ $\overline{PHRESET}$ rise time		100	ns
$t_r(VCC)$ V_{CC} rise time from 1.2 V to V_{CC} minimum	1		ms
t_{d56} Delay from reading minimum V_{CC} during power-up to valid LBCLK1, LBCLK2 with $\overline{PHRESET}$ active		90	ms

$\overline{PHRESET}$ timing

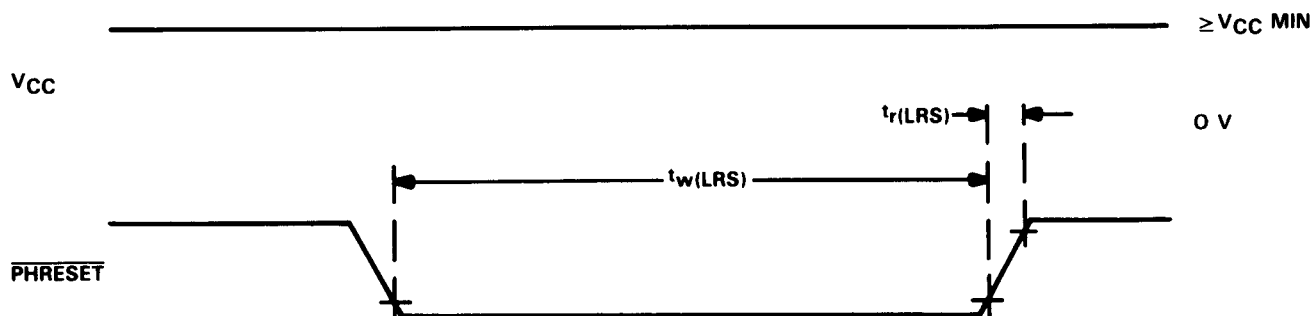

TMS38021 PROTOCOL HANDLER

power-up, LBCLK, and $\overline{\text{PHRESET}}$ timing

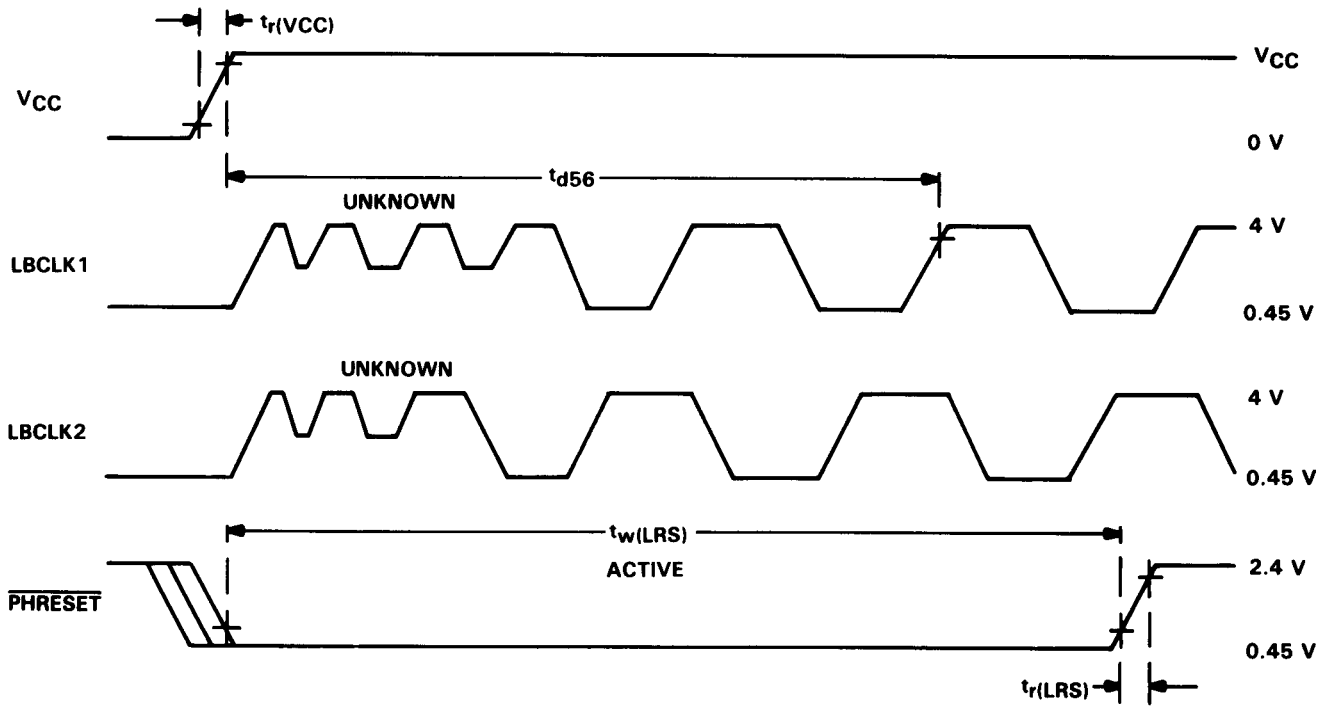

NOTE 11: The timing reference points for VCC are 4.5 V and 1.2 V. The timing reference points for LBCLK1 and LBCLK2 are 3 V and 0.8 V. The timing reference points for $\overline{\text{PHRESET}}$ are 2 V and 0.8 V

EXTERNAL COPY HARDWARE INTERFACE (\overline{XMATCH} , \overline{XFAIL})

timing requirements over recommended supply voltage range and operating free-air temperature range

		MIN	NOM	MAX	UNIT
t_{h4}	Hold time, \overline{XMATCH} , \overline{XFAIL} inactive-high after driven as outputs by TMS38021			6Q	ns
t_{wL1}	Pulse duration low, \overline{XMATCH} , \overline{XFAIL}	50			ns

switching characteristics over recommended supply voltage range and free-air temperature range

PARAMETER	MIN	TYP	MAX	UNIT
t_{d57}			47	ns
t_{d58}	20			ns

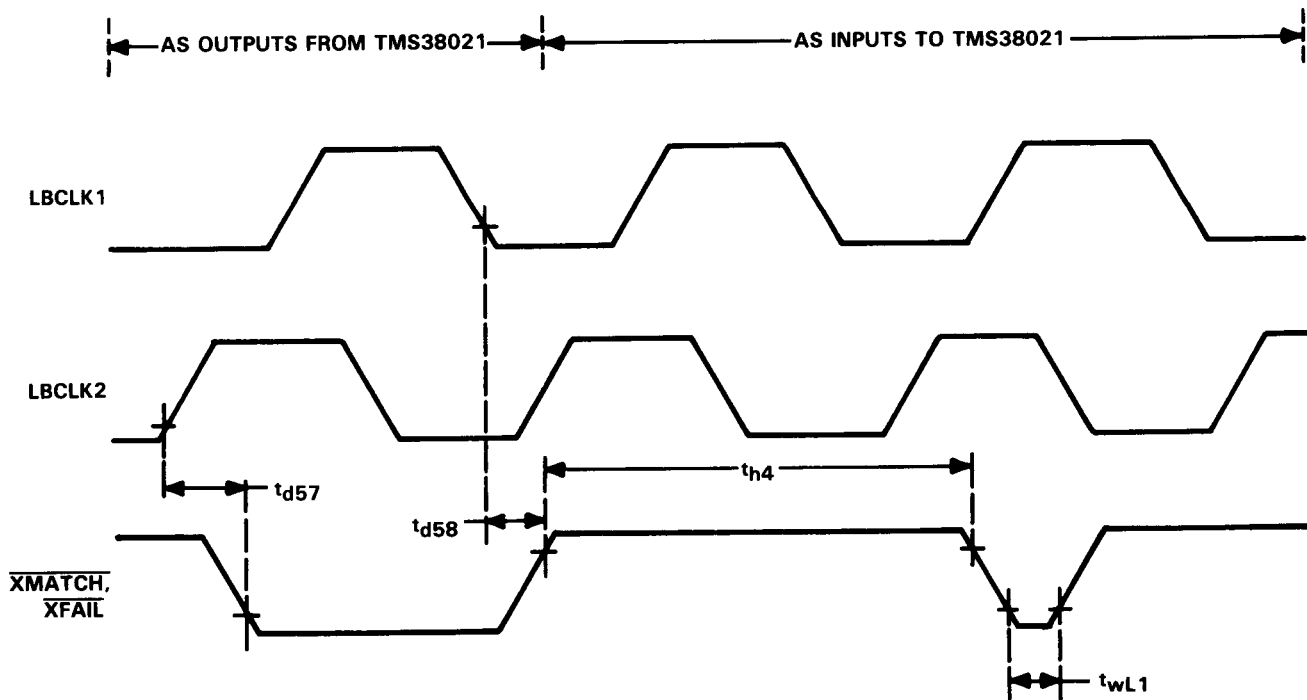

RING INTERFACE TIMING PARAMETERS

timing requirements over recommended supply voltage range and operating free-air temperature range

		MIN	MAX	UNIT
$t_{c(RC)}$	RCLK cycle time (Note 14)	124.875	125.125	ns
$t_{c(PX)}$	PXTALIN cycle time	124.875	125.125	
$t_w(RCL)$	Pulse duration, RCLK and PXTALIN low (Notes 15, 16, 17)	46		
$t_w(RCH)$	Pulse duration, RCLK and PXTALIN high (Notes 15, 16, 17)	35		
$t_{su(RCVR)}$	Setup time, RCVR valid before RCLK no longer low	20		
$t_h(RCVR)$	Hold time, RCVR valid after RCLK high	20		
$t_t(RC)$	Transition time, RCLK and PXTALIN		16	

- NOTES: 14. The nominal value for $t_{c(RC)}$ is 125 ns \pm 0.1%.
 15. The nominal value for $t_w(RCL)$ and $t_w(RCH)$ is 62.5 ns.
 16. RCVR and RCLK are driven to a high level of 2.8 V and a low level of 0.45 V during parametric tests. Timing parameters are measured from a high level of 2.6 V and a low level of 0.6 V except where shown otherwise.
 17. PXTALIN is driven to a high level of 2.4 V and a low level of 0.45 V during parametric tests. Timing parameters are measured from a high level of 2 V and a low level of 0.8 V.

switching characteristics over recommended supply voltage range and operating free-air temperature range

PARAMETER		MIN	MAX	UNIT
$t_h(DRVR)$	Hold time, DRVR after RCLK or PXTALIN to 1.5 V level (Note 18)	12		ns
$t_d(DRVR)$	Delay time, RCLK or PXTALIN at 1.5 V level to DRVR at 1.5 V (Note 18)		40	
$t_d(TRAN)$	Delay time, data transition on DRVR ($t_d(DRVR) - t_h(DRVR)$)		5	

NOTE: 18. Timing parameters of DRVR are measured from a 1.5 V level on RCLK or PXTALIN to a 1.5 V level on DRVR.

ring interface timing

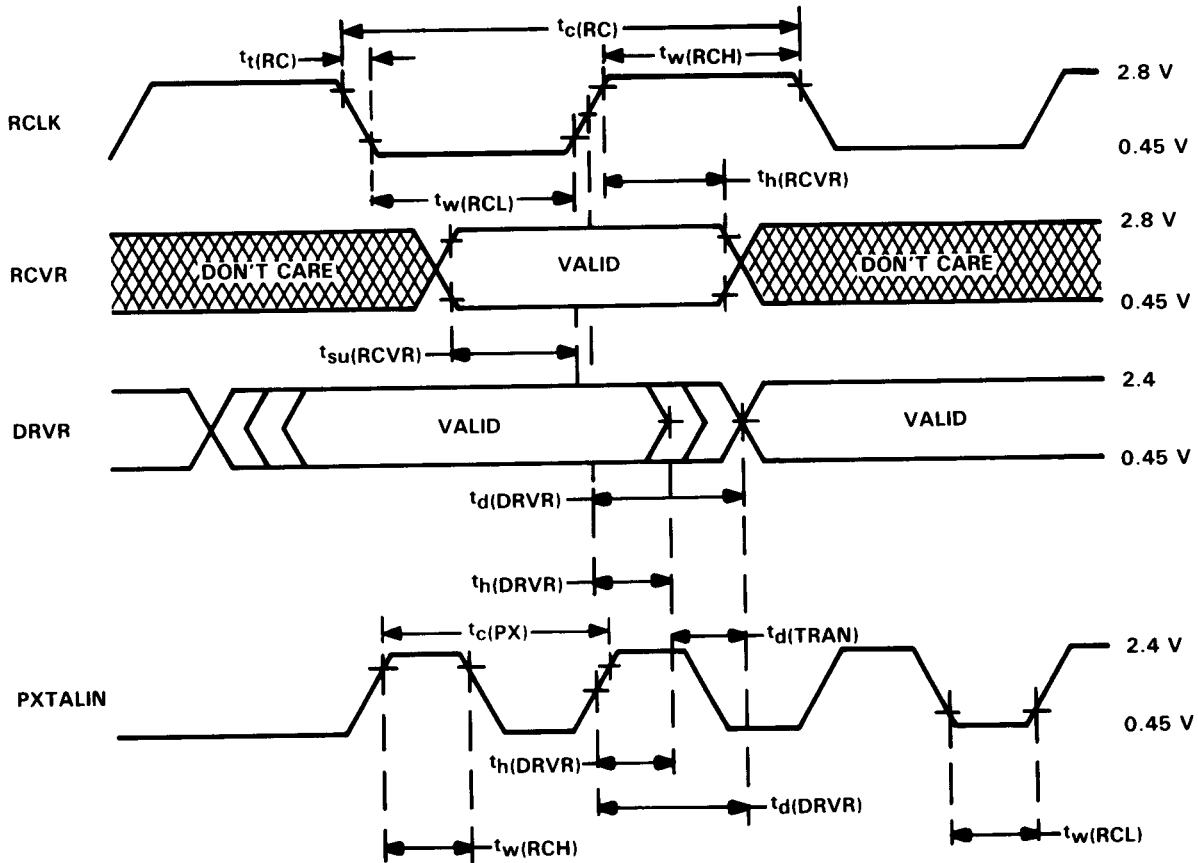

NOTE 19: The timing reference points for RCVR and RCLK are 2.6 V and 0.6 V. The timing reference points for PXTALIN are 2 V and 0.8 V. The intermediate reference point for RCLK and DRVR is 1.5 V.