



The Infinite Bandwidth Company™

MICRF004

QwikRadio™ Low-Power VHF Receiver

Final Information

General Description

The MICRF004 QwikRadio™ VHF receiver is a single-chip OOK (on-off keyed) receiver IC for remote wireless applications. This device is a true single-chip, “antenna-in, data-out” device. All RF and IF tuning is accomplished automatically within the IC which eliminates manual tuning production costs and results in a highly reliable, extremely low-cost solution for high-volume wireless applications.

The MICRF004 is extremely easy to apply, minimizing design and production costs, and improving time to market. The MICRF004 provides two fundamental modes of operation, fixed and sweep.

In fixed mode, the device functions as a conventional superheterodyne receiver with an internal local oscillator operating at a single frequency based on an external reference crystal or clock. Fixed mode is for use with accurately-controlled transmitters utilizing crystal or SAW (surface acoustic wave) resonators.

In sweep mode, the MICRF004 sweeps the internal local oscillator at rates greater than the baseband data rate. This effectively broadens the RF bandwidth of the receiver to a value equivalent to conventional superregenerative receivers. This allows the MICRF004 to operate with less expensive LC transmitters without additional components or tuning, even though the receiver topology is still superheterodyne. In this mode the reference crystal can be replaced with a less expensive ±0.5% ceramic resonator.

The MICRF004 features a shutdown control, which may be used for duty-cycled operation, and a wake-up output, which provides a logical indication of an incoming RF signal. These features make the MICRF004 ideal for low- and ultra-low-power applications, such as RKE (remote keyless entry) and RFID (RF identification).

Since all post-detection (demodulator) data filtering is provided on the MICRF004, no external filters are required. One of the four internal filter bandwidths must be externally selected based on data rate and code modulation format. Bandwidths range in binary steps, from 0.55kHz to 4.4kHz (sweep mode) or 1.1kHz to 8.8kHz (fixed mode).

Features

- Complete VHF receiver on a monolithic chip
- 140MHz to 200MHz frequency range
- >200 meters typical range with monopole antenna
- 2.5kb/s sweep- and 10kb/s fixed-mode data rates
- Automatic tuning, no manual adjustment
- No filters or inductors required
- Low 240µA operating supply current at 150MHz (10:1 duty cycle)
- Shutdown mode for >100:1 duty-cycle operation
- Wakeup for enabling decoders and microprocessors
- Very low RF antenna reradiation
- CMOS logic interface for standard ICs
- Extremely low external part count

Applications

- Automotive remote keyless entry
- Long range RF identification
- Remote fan and light control
- Garage door and gate openers

Ordering Information

Part Number	Junction Temp. Range	Package
MICRF004BM	-40°C to +85°C	16-Lead SOP
MICRF004BN	-40°C to +85°C	16-Pin DIP

8-pin versions available. See “Custom 8-Pin Options,” following page.

Typical Application

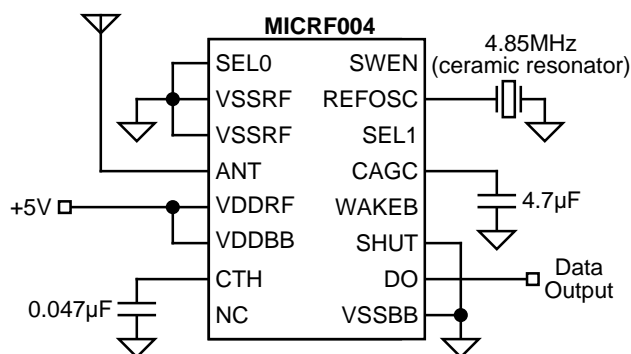

150MHz 1200b/s On-Off Keyed Receiver

QwikRadio is a trademark of Micrel, Inc. The QwikRadio ICs were developed under a partnership agreement with AIT of Orlando, Florida.

Micrel, Inc. • 1849 Fortune Drive • San Jose, CA 95131 • USA • tel + 1 (408) 944-0800 • fax + 1 (408) 944-0970 • http://www.micrel.com

Pin Configuration

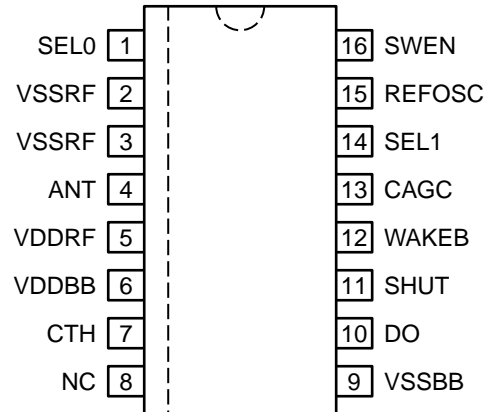

16-Pin DIP (N) or SOP (M) Packages

Pin Description

Pin Number 16-Pin Pkg.	Pin Number 8-Pin Pkg.	Pin Name	Pin Function
1		SEL0	Bandwidth Selection Bit 0 (Input): Configure with SEL1 to set the desired demodulator filter bandwidth. See Table 1. Internally pulled-up to VDDRF.
2, 3	1	VSSRF	RF [Analog] Return (Input): Ground return to the RF section power supply. See "Application Information" for bypass capacitor details.
4	2	ANT	Antenna (Input): High-impedance, internally ac coupled receiver input. Connect this pin to the receive antenna. This FET gate input has approximately 2pF of shunt (parasitic) capacitance. See "Applications Information" for optional band-pass filter information.
5	3	VDDRF	RF [Analog] Supply (Input): Positive supply input for the RF section of the IC. VDDBB and VDDRF should be connected together directly at the IC pins. Connect a low ESL, low ESR decoupling capacitor from this pin to VSSRF, as short as possible.
6		VDDBB	Base-Band [Digital] Supply (Input): Positive supply input for the baseband section of the IC. VDDBB and VDDRF should be connected together at the IC pins.
7	4	CTH	[Data Slicing] Threshold Capacitor (External Component): Capacitor extracts the dc average value from the demodulated waveform which becomes the reference for the internal data slicing comparator. See "Applications Information" for selection.
8		NC	not internally connected
9		VSSBB	Base-Band [Digital] Return (Input): Ground return to the baseband section power supply. See "Application Information" for bypass capacitor and layout details.
10	5	DO	Digital Output (Output): CMOS-level compatible data output signal.
11	6	SHUT	Shutdown (Input): Shutdown-mode logic-level control input. Pull low to enable the receiver. This input has an internal pulled-up to VDDRF.
12		WAKEB	Wakeup (Output): Active-low output that indicates detection of an incoming RF signal. Signal is determined by monitoring for data preamble. CMOS-level compatible.
13	7	CAGC	AGC Capacitor (External Component): Integrating capacitor for on-chip AGC (automatic gain control). The decay/attack time-constant (τ) ratio is nominally 10:1. See "Applications Information" for capacitor selection.
14		SEL1	Bandwidth Selection Bit 1 (Input): Configure with SEL0, programs to set the desired demodulator filter bandwidth. See Table 1. Internally pulled-up to VDDRF.
15	8	REFOSC	Reference Oscillator (External Component or Input): Timing reference for on-chip tuning and alignment. Connect either a ceramic resonator or crystal (mode dependent, see "Application Information"). between this pin and VSSBB, or drive the input with an ac-coupled 0.5Vpp input clock.
16		SWEN	Sweep-Mode Enable (Input): Sweep- or fixed-mode operation control input. When VSWEN is high, the MICRF004 is in sweep mode; when SWEN is low, the receiver operates as a conventional single-conversion superheterodyne receiver. This pin is internally pulled-up to VDDRF.

Absolute Maximum Ratings (Note 1)

Supply Voltage (V_{DDRF}, V_{DDBB})	+7V
Reference Oscillator Input Voltage (V_{REFOSC})	V_{DDBB}
Input/Output Voltage ($V_{I/O}$)	$V_{SS}-0.3$ to $V_{DD}+0.3$
Junction Temperature (T_J)	+150°C
Storage Temperature Range (T_S)	-65°C to +150°C
Lead Temperature (soldering, 10 sec.)	+260°C
ESD Rating, Note 3	

Operating Ratings (Note 2)

Supply Voltage (V_{DDRF}, V_{DDBB})	+4.75V to +5.5V
Ambient Temperature (T_A)	-40°C to +85°C
Package Thermal Resistance (θ_{JA})	
16-pin DIP (θ_{JA})	90°C/W
16-pin SOIC (θ_{JA})	120°C/W

Electrical Characteristics

$V_{DDRF} = V_{DDBB} = V_{DD}$ where $+4.75V \leq V_{DD} \leq 5.5V$, $V_{SS} = 0V$; $C_{AGC} = 4.7\mu F$, $C_{TH} = 0.047\mu F$; $f_{REFOSC} = 4.65MHz$; $T_A = 25^\circ C$, **bold** values indicate $-40^\circ C \leq T_A \leq +85^\circ C$; current flow into device pins is positive; unless noted.

Symbol	Parameter	Condition	Min	Typ	Max	Units
I_{OP}	Operating Current	continuous operation		2.4		mA
		10:1 duty cycle		240		μA
I_{STBY}	Standby Current	$V_{SHUT} = V_{DD}$		0.35		μA

RF Section, IF Section

	Receiver Sensitivity	Notes 4, 6		-80		dBm
f_{IF}	IF Center Frequency	Note 7		0.86		MHz
f_{BW}	IF 3dB Bandwidth	Notes 6, 7		0.43		MHz
f_{ANT}	RF Input Range		145		200	MHz
$Z_{IN(ant)}$	Antenna Input Impedance	$f_{IN} = 150MHz$		422		Ω
	Receive Modulation Duty-Cycle		20		80	%
	Maximum Receiver Input	$R_{SC} = 50\Omega$		-20		dBm
	Spurious Reverse Isolation	ANT pin, $R_{SC} = 50\Omega$, Note 5		30		μV_{rms}
	AGC Attack to Decay Ratio	$t_{ATTACK} \div t_{DECAY}$		0.1		
	AGC Leakage Current	$T_A = +85^\circ C$			+200	nA

Reference Oscillator

Z_{REFOSC}	Reference Oscillator Stabilization Time	external reference (250mV peak)		6		ms
		ceramic resonator		5		ms
		crystal		10		ms
Z_{REFOSC}	Reference Oscillator Input Impedance			290		k Ω
	Reference Oscillator Input Sensitivity	Note 10	0.1		2	Vp-p
I_{REFOSC}	Reference Oscillator Current			4.5		μA

Demodulator

Z_{CTH}	CTH Source Impedance	Note 8		124		k Ω
ΔZ_{CTH}	CTH Source Impedance Variation			± 15		%
$I_{Z_{CTH(leak)}}$	CTH Leakage Current	$T_A = +85^\circ C$		± 200		nA
	Demodulator Filter Bandwidth	$V_{SEL0} = V_{SEL1} = V_{SWEN} = V_{DD}$, Notes 7, 9		3960		Hz
	Demodulator Filter Bandwidth	$V_{SEL0} = V_{SEL1} = V_{DD}$, $V_{SWEN} = V_{SS}$, Note 7, 9		7930		Hz

Symbol	Parameter	Condition	Min	Typ	Max	Units
Digital/Control Section						
$I_{IN(pu)}$	Input Pull up Current	SEL0, SEL1, SWEN, $V_{SHUT} = V_{SS}$		8		μA
$V_{IN(high)}$	Input High Voltage	SEL0, SEL1, SWEN			$0.8V_{DD}$	V
$V_{IN(low)}$	Input Low Voltage	SEL0, SEL1, SWEN	$0.2V_{DD}$			V
I_{OUT}	Output Current	DO, WAKEB pins, push-pull		10		μA
$V_{OUT(high)}$	Output High Voltage	DO, WAKEB pins, $I_{OUT} = -1\mu A$	$0.9V_{DD}$			V
$V_{OUT(low)}$	Output Low Voltage	DO, WAKEB pins, $I_{OUT} = +1\mu A$			$0.1V_{DD}$	V
t_R, t_F	Output Rise and Fall Times	DO, WAKEB pins, $C_{LOAD} = 15pF$			10	μs
t_{WAKEB}	Wakeup Output Time	$RF_{IN} = TBDdBm,$ $V_{SEL0} = V_{SEL1} = V_{SWEN} = V_{SHUT} = V_{SS}$		4		ms

Note 1. Exceeding the absolute maximum rating may damage the device.

Note 2. The device is not guaranteed to function outside its operating rating.

Note 3. Devices are ESD sensitive. Use appropriate ESD precautions. Meets class 1 ESD test requirements, (human body model HBM), in accordance with MIL-STD-883C, method 3015. Do not operate or store near strong electrostatic fields.

Note 4: Sensitivity is defined as the average signal level measured at the input necessary to achieve 10^{-2} BER (bit error rate). The input signal is defined as a return-to-zero (RZ) waveform with 50% average duty cycle (Manchester encoded data) at a data rate of 300b/s. The RF input is assumed to be matched into 50Ω .

Note 5: Spurious reverse isolation represents the spurious components which appear on the RF input pin (ANT) measured into 50Ω with an input RF matching network.

Note 6: Sensitivity, a commonly specified receiver parameter, provides an indication of the receiver's input referred noise, generally input thermal noise. However, it is possible for a more sensitive receiver to exhibit range performance no better than that of a less sensitive receiver if the background noise is appreciably higher than the thermal noise. Background noise refers to other interfering signals, such as FM radio stations, pagers, etc.

A better indicator of achievable receiver range performance is usually given by its selectivity, often stated as intermediate frequency (IF) or radio frequency (RF) bandwidth, depending on receiver topology. Selectivity is a measure of the rejection by the receiver of "ether" noise. More selective receivers will almost invariably provide better range. Only when the receiver selectivity is so high that most of the noise on the receiver input is actually thermal will the receiver demonstrate sensitivity-limited performance.

Note 7: Parameter scales linearly with reference oscillator frequency f_T . For any reference oscillator frequency other than 4.65MHz, compute new parameter value as the ratio:

$$\frac{f_{REFOSC}MHz}{4.65} \times (\text{parameter value at 4.65MHz})$$

Example: For reference oscillator frequency $f_T = 6.00MHz$:

$$(\text{parameter value at 6.00MHz}) = \frac{6.00}{4.65} \times (\text{parameter value at 4.65MHz})$$

Note 8: Parameter scales inversely with reference oscillator frequency f_T . For any reference oscillator frequency other than 4.65MHz, compute new parameter value as the ratio:

$$\frac{4.65}{f_{REFOSC}MHz} \times (\text{parameter value at 4.65MHz})$$

Example: For reference oscillator frequency $f_T = 6.00MHz$:

$$(\text{parameter value at 4.65MHz}) = \frac{4.65}{6.00} \times (\text{parameter value at 4.65MHz})$$

Note 9: Demodulator filter bandwidths are related in a binary manner, so any of the (lower) nominal filter values may be derived simply by dividing this parameter value by 2, 4, or 8 as desired.

Note 10: External signal generator used. When a crystal or ceramic resonator is used, the minimum voltage is 300mVp-p. The reference oscillator voltage amplitude is a function of the quality of the ceramic or crystal resonator.

Typical Characteristics

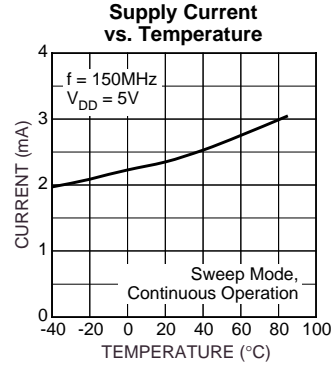
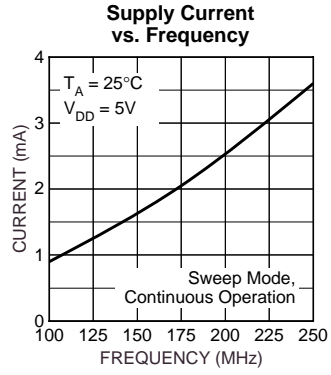

Functional Characteristics

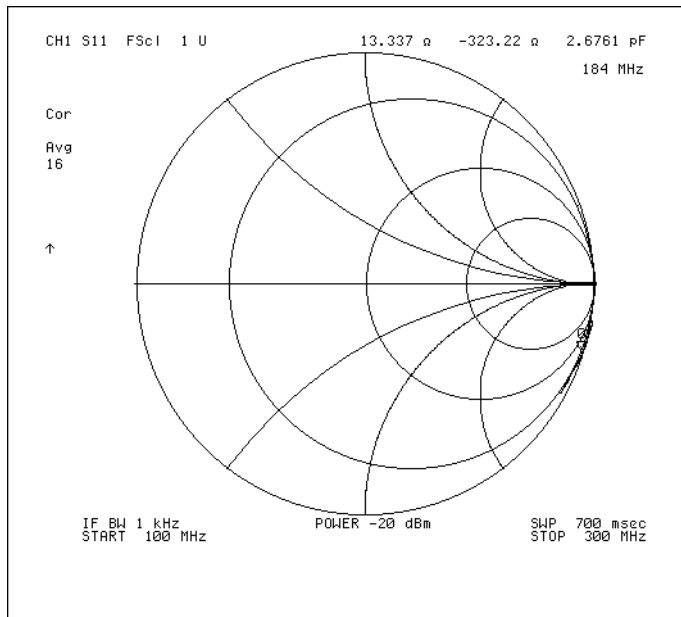

Antenna Impedance

Frequency	Complex Impedance	Capacitance
140MHz	12.53-j4.31.14	2.63pF
149MHz	15.6-j406.87	2.63pF
160MHz	15.18-j377.78	2.63pF
170MHz	14.39-j355.36	2.63pF
173MHz	13.51-j347.24	2.64pF
180MHz	14.79-j333.98	2.64pF
184MHz	13.47-j327.10	2.65pF
190MHz	11.15-j316.43	2.65pF

Functional Diagram

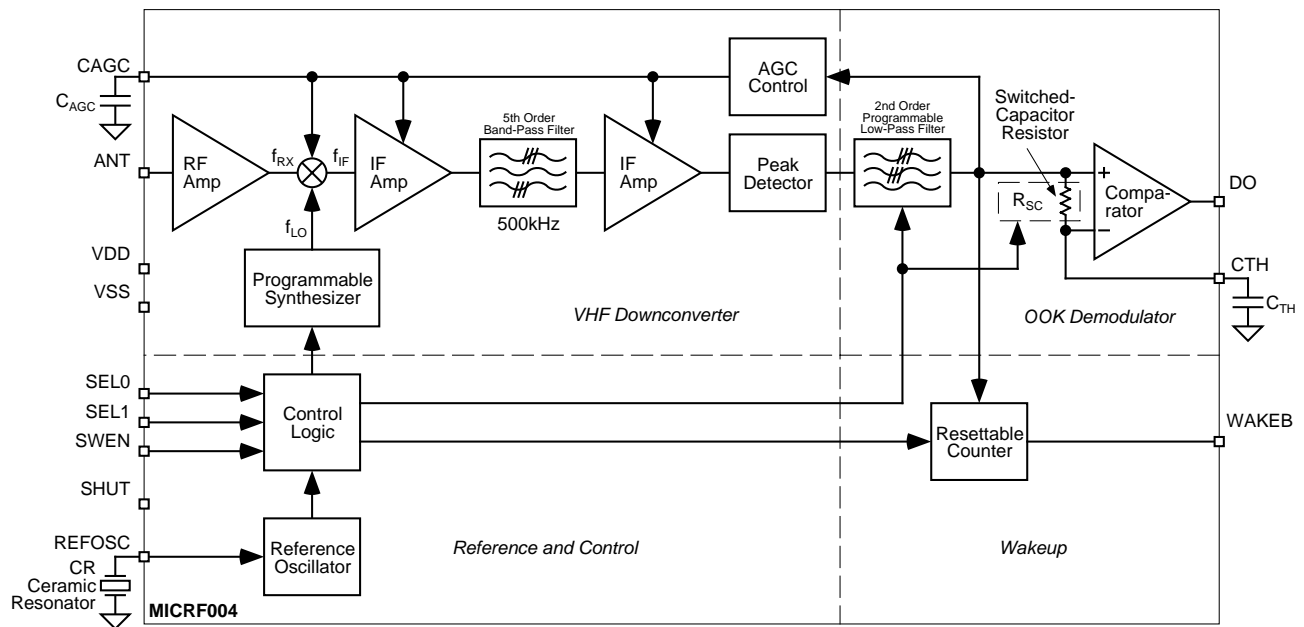

Functional Description

Refer to "MICRF004 Block Diagram". Identified in the block diagram are the four sections of the IC: UHF Downconverter, OOK Demodulator, Reference and Control, and Wakeup. Also shown in the figure are two capacitors (C_{TH} , C_{AGC}) and one timing component (CR), usually a ceramic resonator. With the exception of a supply decoupling capacitor, these are the only external components needed by the MICRF004 to assemble a complete UHF receiver. Four control inputs are shown in the block diagram: SEL0, SEL1, SWEN, and SHUT. Using these logic inputs, the user can control the operating mode and selectable features of the IC. These inputs are CMOS compatible, and are pulled-up on the IC.

Sweep-Mode Enable

Logic-input SWEN selects either fixed-mode or sweep-mode operation. When SWEN is low, the IC is in fixed mode, and functions as a conventional superheterodyne receiver. When SWEN is high, the IC is in sweep mode.

Fixed-Mode Operation

For applications where the transmit frequency must be accurately set (that is, applications where a SAW transmitter is used for its mechanical stability), the MICRF004 may be configured as a standard superheterodyne receiver (fixed mode). Fixed-mode operation receives a narrower bandwidth making it less susceptible to competing signals. Fixed mode is selected by connecting SWEN to ground which forces the on-chip LO frequency to a fixed value. In fixed mode a crystal (higher frequency tolerance) must be used instead of a ceramic resonator (lower frequency tolerance). Data rates beyond 10kb/s are possible in fixed mode.

Sweep-Mode Operation

In sweep mode, while the topology is still superheterodyne, the LO (local oscillator) is deterministically swept over a range of frequencies at rates greater than the data rate. When coupled with a peak-detecting demodulator, this technique effectively increases the RF bandwidth of the MICRF004, allowing the device to operate in applications where significant transmitter-receiver frequency misalignment may exist.

The swept-LO technique does not affect the IF bandwidth, therefore noise performance is not degraded relative to fixed mode. The IF bandwidth is 500kHz whether the device is operating in fixed or sweep mode.

Due to limitations imposed by the LO sweeping process, the upper limit on data rate in sweep mode is approximately 2.5kb/s.

Examples of sweep-mode operation include applications utilizing low-cost LC-based transmitters, where the transmit frequency may vary up to $\pm 0.5\%$ over initial tolerance, aging, and temperature. In sweep mode, the LO frequency is varied in a defined fashion which results in downconversion of all signals in a band approximately 1.5% around the nominal transmit frequency. The transmitter may drift up to $\pm 0.5\%$ without the need to retune the receiver and without impacting system performance. Similar performance is not currently available with crystal-based superheterodyne receivers which can operate only with SAW- or crystal-based transmitters.

In sweep mode only, a range reduction will occur in installations where there is an undesired competing signal of sufficient strength within of 2% to 3% around the transmit frequency. This is because the process indiscriminately in-

cludes all signals within the sweep range. This same range reduction also occurs with superregenerative receivers as their RF bandwidth is also generally 2% to 3% around the nominal transmit frequency. Any superregenerative receiver application can instead use a MICRF004 in sweep mode.

IF Bandpass Filter

Rolloff response of the IF Filter is 5th order, while the demodulator data filter exhibits a 2nd order response. The multiplication factor between the reference oscillator frequency f_T and the internal local oscillator (LO) is $32.5\times$ for fixed mode, and $32.25\times$ for sweep mode (that is, for $f_T = 6.00\text{MHz}$ in fixed mode, $f_{LO} = 6.00\text{MHz} \times 32.5 = 195.0\text{MHz}$).

Bandwidth

The inputs SEL0 and SEL1 control the demodulator filter bandwidth in four binary steps (550Hz to 4400Hz in sweep, 1100Hz to 8800Hz in fixed mode). Bandwidth must be selected according to the application. See "Applications Information" for the bandwidth programming table.

Slicing Level

Extraction of the dc value of the demodulated signal for purposes of logic-level data slicing is accomplished using the external threshold capacitor C_{TH} and the on-chip switched-capacitor "resistor" R_{SC} , shown in the block diagram. Since the effective resistance of R_{SC} is $124\text{k}\Omega$, the CTH connection can be considered a low-pass RC filter with source impedance of $124\text{k}\Omega$.

Slicing level time constant values vary somewhat with decoder type, data pattern, and data rate, but typical values range from 5ms to 50ms. Optimization of the value of C_{TH} is required to maximize range.

Automatic Gain Control

The signal path has AGC (automatic gain control) to increase input dynamic range. An external capacitor, C_{AGC} , must be connected to the CAGC pin of the device. The ratio of decay-to-attack time-constant is fixed at 10:1 (that is, the attack time constant is 1/10th of the decay time constant), and this ratio cannot be changed by the user. However, the attack time constant is set externally by choosing a value for C_{AGC} .

The AGC control voltage is carefully managed on-chip to allow duty-cycle operation of the MICRF004 in excess of 100:1. When the device is placed into shutdown mode (SHUT pin pulled high), the AGC capacitor floats, to retain the voltage. When operation is resumed, only the voltage droop on the capacitor due to leakage must be replenished, therefore a relatively low-leakage capacitor is recommended for duty-cycled operation. The actual tolerable leakage will be application dependent. Clearly, leakage performance is less critical when the device off-time is low (milliseconds) and more critical when the off-time is high (seconds).

To further enhance duty-cycled operation of the IC, the AGC push and pull currents are increased for a fixed time immedi-

ately after the device is taken out of shutdown mode (turned-on). This compensates for AGC capacitor voltage droop while the IC is in shutdown mode, reduces the time to restore the correct AGC voltage, and therefore extends maximum achievable duty ratios. Push-pull currents are increased by 45 times their nominal values. The fixed time period is based on the reference oscillator frequency f_T , 10.9ms for $f_T = 6.00\text{MHz}$, and varies inversely as f_T varies.

Reference Oscillator

All timing and tuning operations on the MICRF004 are derived from the internal Colpitts reference oscillator. Timing and tuning is controlled through the REFOSC pin in one of three ways:

1. Connect a ceramic resonator
2. Connect a crystal
3. Drive this pin with an external timing signal

The third approach is attractive for lowering system cost further if an accurate reference signal exists elsewhere in the system, for example, a reference clock from a crystal- or ceramic-resonator-controlled microprocessor. An externally applied signal should be ac-coupled and resistively-attenuated, or otherwise limited, to approximately 0.5Vpp. The specific reference frequency required is related to the system transmit frequency and to the operating mode of the receiver as set by the SWEN pin.

Wake-Up Function

The wake-up circuit is available for reducing power consumption of the overall wireless system. WAKEB is an output logic signal, which goes active low when the IC detects a constant RF carrier "header" in the demodulated output signal. This output may be used to enable external circuits, such as a data decoder or microprocessor, when there is a detection of an incoming RF signal. The wake-up function is unavailable when the IC is in shutdown mode.

The wake-up function consists of a resettable counter, based on an internal 23.4kHz clock (created from a 6.0MHz reference frequency). When this constant carrier is detected, without interruption for 128 clock cycles of 25kHz or 5.12ms, WAKEB will transition low and stay low until data begins. This approach is utilized over others because constant tones in excess of 5ms are rare, resulting in few false detections, and this technique does not require the introduction of a signal path offset which impacts achievable range.

Shutdown Function

The shutdown function is controlled by a logic state applied to the SHUT pin. When V_{SHUT} is high, the device goes into low-power standby mode, consuming less than $1\mu\text{A}$. This pin is pulled high internally. It must be externally pulled low to enable the receiver.

I/O Pin Interface Circuitry

Interface circuitry for the various I/O pins of the MICRF004 are diagrammed in Figures 1 through 6. The ESD protection diodes at all input and output pins are not shown.

ANT Pin

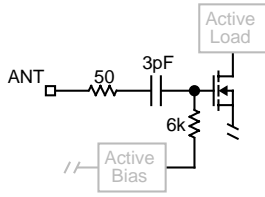

Figure 1. ANT Pin

The ANT pin is internally ac-coupled, through a 3pF capacitor, to an RF N-channel MOSFET, as shown in Figure 1. Impedance from this pin to VSS is high at low frequencies and decreases as frequency increases. In the VHF frequency range, the device input can be modeled as a 6.3kΩ in parallel with 2pF (pin capacitance) shunt to the VSSRF pin.

CTH Pin

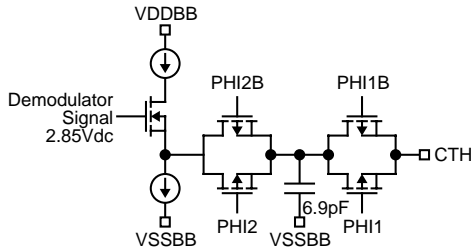

Figure 2. CTH Pin

Figure 2 illustrates the CTH-pin interface circuit. The CTH pin is driven from a P-channel MOSFET source-follower with approximately 10μA of bias. Transmission gates TG1 and TG2 isolate the 6.9pF capacitor. Internal control signals PHI1/PHI2 are related in a manner such that the impedance across the transmission gates looks like a “resistance” of approximately 100kΩ. The dc potential at the CTH pin is approximately 1.6V

CAGC Pin

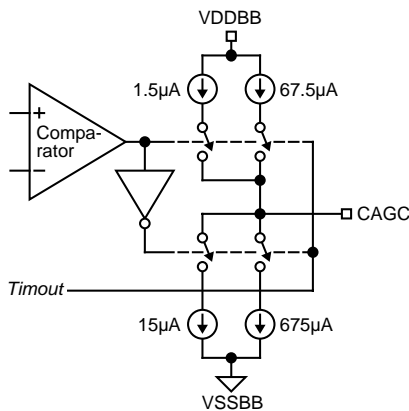

Figure 3. CAGC Pin

Figure 3 illustrates the CAGC pin interface circuit. The AGC control voltage is developed as an integrated current into a capacitor C_{AGC}. The attack current is nominally 15μA, while the decay current is a 1/10th scaling of this, nominally 1.5μA, making the attack/decay timeconstant ratio a fixed 10:1. Signal gain of the RF/IF strip inside the IC diminishes as the voltage at CAGC decreases. Modification of the attack/decay ratio is possible by adding resistance from the CAGC pin to either V_{DDBB} or V_{SSBB}, as desired.

Both the push and pull current sources are disabled during shutdown, which maintains the voltage across C_{AGC}, and improves recovery time in duty-cycled applications. To further improve duty-cycle recovery, both push and pull currents are increased by 45 times for approximately 10ms after release of the SHUT pin. This allows rapid recovery of any voltage droop on C_{AGC} while in shutdown.

DO and WAKEB Pins

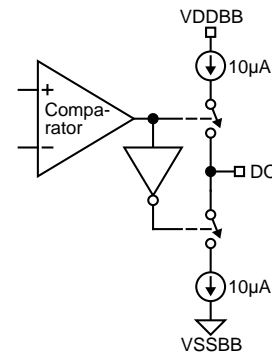

Figure 4. DO and WAKEB Pins

The output stage for DO (digital output) and WAKEB (wakeup output) is shown in Figure 4. The output is a 10μA push and 10μA pull switched-current stage. This output stage is capable of driving CMOS loads. An external buffer-driver is recommended for driving high-capacitance loads.

REFOSC Pin

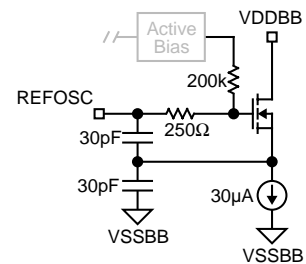
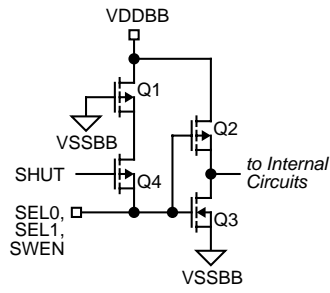
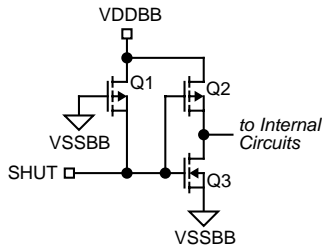

Figure 5. REFOSC Pin

The REFOSC input circuit is shown in Figure 5. Input impedance is high (200kΩ). This is a Colpitts oscillator with internal 30pF capacitors. This input is intended to work with standard ceramic resonators connected from this pin to the VSSBB pin, although a crystal may be used when greater frequency accuracy is required. The nominal dc bias voltage on this pin is 1.4V.

SEL0, SEL1, SWEN, and SHUT Pins**Figure 6a. SEL0, SEL1, SWEN****Figure 6b. SHUT**

Control input circuitry is shown in Figures 6a and 6b. The standard input is a logic inverter constructed with minimum geometry MOSFETs (Q2, Q3). P-channel MOSFET Q1 is a large channel length device which functions essentially as a “weak” pullup to VDDBB. Typical pullup current is $5\mu\text{A}$, leading to an impedance to the VDDBB supply of typically $1\text{M}\Omega$.

Application Information

Transmitter Compatibility

Generally, the MICRF004 can be operated in sweep mode, using a low-cost ceramic resonator. Sweep mode works with LC-, crystal-, or SAW-based transmitters, without any significant range difference. In fixed mode a SAW-based or crystal-controlled transmitter must be used.

Bypass and Output Capacitors

The bypass and output capacitors connected to VSSBB should have the shortest possible lead lengths. For best performance, connect VSSRF to VSSBB at the power supply only (that is, keep V_{SSBB} currents from flowing through the V_{SSRF} return path).

Crystal or Ceramic Resonator Selection

Do not use resonators with integral capacitors since capacitors are included in the IC.

If operating in fixed mode, a crystal must be used. In sweep mode, either a crystal or ceramic resonator may be used.

External Timing Signals

Externally applied signals should be ac-coupled and the amplitude must be limited to approximately 0.5Vpp.

Bandwidth Programming

Bandwidth must be selected according to the application.

SEL0	SEL1	Demodulator Bandwidth	
		Sweep Mode	FIXED Mode
1	1	4400Hz	8800Hz
0	1	2200Hz	4400Hz
1	0	1100Hz	2200Hz
0	0	550Hz	1100Hz

Table 1. Bandwidth Selection

Optional BandPass Filter

For applications located in high ambient noise environments, a fixed value band-pass network may be connected between the ANT pin and VSSRF to provide additional receive selectivity and input overload protection. A typical filter is included in Figure 7a.

Squelch

During quiet periods (no signal) the data output (DO pin) transitions randomly with noise, presenting problems for some decoders. A simple solution is to introduce a small offset, or squelch voltage, on the CTH pin so that noise does not trigger the internal comparator. Usually 20mV to 30mV is sufficient, and may be introduced by connecting a several-megohm resistor from the CTH pin to either V_{SS} or V_{DD} , depending on the desired offset polarity. Since the MICRF004 has receiver AGC, noise at the internal comparator input is always the same, set by the AGC. The squelch offset requirement does not change as the local noise strength changes from installation to installation. Introducing squelch will reduce range modestly. Only introduce an amount of offset sufficient to quiet the output.

Utilizing Wake-Up

To utilize the wake-up function, a burst of RF carrier in excess of 5.5ms must be received at the start of *each* data code word (preferred for best communication reliability) or a single 5.5ms RF carrier tone must be received at the start of the data pattern. When this constant carrier is detected, without interruption, WAKEB will transition low and stay low until data begins.

For designers who wish to use the wakeup function while squelching the output, a positive squelching offset voltage must be used. This simply requires that the squelch resistor be connected to a voltage more positive than the quiescent voltage on the CTH pin so that the data output is low in absence of a transmission.

AGC Configuration

By adding resistance from the CAGC pin to VDDBB or VSSBB in parallel with the AGC capacitor, the ratio of decay-to-attack time constant may be varied, although the value of such adjustments must be studied on a per-application basis. Generally the design value of 10:1 is adequate for the vast majority of applications.

To maximize system range, it is important to keep the AGC control voltage ripple low, preferably under 10mVpp once the control voltage has attained its quiescent value. For this reason capacitor values of at least 0.47 μ F are recommended.

Frequency and Capacitor Selection

Selection of the reference oscillator frequency f_T , slicing level capacitor (C_{TH}), and AGC capacitor (C_{AGC}) are briefly summarized in this section.

Selecting Reference Oscillator Frequency f_T (Fixed Mode)

As with any superheterodyne receiver, the difference between the internal LO (local oscillator) frequency f_{LO} and the incoming transmit frequency f_{TX} ideally must equal the IF center frequency. Equation 1 may be used to compute the appropriate f_{LO} for a given f_{TX} :

$$(1) \quad f_{LO} = f_{TX} \pm \left(0.787 \frac{f_{TX}}{150} \right)$$

Frequencies f_{TX} and f_{LO} are in MHz. Note that two values of f_{LO} exist for any given f_{TX} , distinguished as "high-side mixing" and "low-side mixing," and there is generally no preference of one over the other.

After choosing one of the two acceptable values of f_{LO} , use Equation 2 to compute the reference oscillator frequency f_T :

$$(2) \quad f_T = \frac{f_{LO}}{32.5}$$

Frequency f_T is in MHz. Connect a crystal of frequency f_T to REFOSC on the MICRF004. Four-decimal-place accuracy on the frequency is generally adequate. The following table identifies f_T for some common transmit frequencies when the MICRF004 is operated in fixed mode.

Transmit Frequency f_{TX}	Reference Oscillator Frequency f_T
149.675MHz	4.6318MHz
184.225MHz	5.7010MHz

Table 2. Common Transmitter Frequencies

Selecting REFOSC Frequency f_T (Sweep Mode)

Selection of the reference oscillator frequency f_T in sweep mode is much simpler than in fixed mode due to the LO sweeping process. Also, accuracy requirements of the frequency reference component are significantly relaxed.

In sweep mode, f_T is given by Equation 3:

$$(3) \quad f_T = \frac{f_{LO}}{32.25}$$

Connect a ceramic resonator of frequency f_T to the REFOSC pin on the MICRF004. Two-decimal-place accuracy is generally adequate. A crystal may be used. A crystal may be mandatory in some cases to reduce receive frequency ambiguity if the transmit frequency ambiguity is excessive.

Use Equation 3a to compute sweep-mode frequency band coverage (f_{BC}):

$$(3a) \quad f_{BC} = 0.5f_T + 2f_{IF} + f_{BW}$$

Example:

$$f_{TX} = 170\text{MHz}$$

$$f_T = 5.27\text{MHz}$$

$$f_{IF} = \frac{170}{150} 0.86\text{MHz}$$

$$f_{BW} = \frac{170}{150} 0.43\text{MHz}$$

then:

$$f_{BC} = 5.07\text{MHz}$$

centered symmetrically about 170MHz.

Selecting Capacitor C_{TH}

The first step in the process is selection of a data-slicing-level time constant. This selection is strongly dependent on system issues including system decode response time and data code structure (that is, existence of data preamble, etc.). This issue is covered in more detail in Application Note 22.

Source impedance of the CTH pin is given by equation (4), where f_T is in MHz:

$$(4) \quad R_{SC} = 124\text{k}\Omega \frac{4.65}{f_T}$$

Assuming that a slicing level time constant τ has been established, capacitor C_{TH} may be computed using equation

$$(5) \quad C_{TH} = \frac{\tau}{R_{SC}}$$

A standard $\pm 20\%$ X7R ceramic capacitor is generally sufficient.

Selecting C_{AGC} Capacitor in Continuous Mode

Selection of C_{AGC} is dictated by minimizing the ripple on the AGC control voltage by using a sufficiently large capacitor. Factory experience suggests that C_{AGC} should be in the vicinity of $0.47\mu\text{F}$ to $4.7\mu\text{F}$. Large capacitor values should be carefully considered as this determines the time required for the AGC control voltage to settle from a completely discharged condition. AGC settling time from a completely discharged (zero-volt) state is given approximately by Equation 6:

$$(6) \quad \Delta t = 1.333C_{AGC} - 0.44$$

where:

C_{AGC} is in μF , and Δt is in seconds.

Selecting C_{AGC} Capacitor in Duty-Cycle Mode

Use of $0.47\mu\text{F}$ or greater is strongly recommended for best range performance. Use low-leakage type capacitors (dipped tantalum, ceramic, or polyester) for duty-cycled operation to minimize AGC control voltage droop.

Generally, droop of the AGC control voltage during shutdown should be replenished as quickly as possible after the IC is "turned-on". As described in the functional description, for about 10ms after the IC is turned on, the AGC push-pull currents are increased to 45 times their normal values. Consideration should be given to selecting a value for C_{AGC} and a shutdown time period such that the droop can be replenished within this 10ms period.

Polarity of the droop is unknown, meaning the AGC voltage could droop up or down. Worst-case from a recovery standpoint is downward droop, since the AGC pullup current is 1/10th magnitude of the pulldown current. The downward droop is replenished according to the Equation 7:

$$(7) \quad \frac{I}{C_{AGC}} = \frac{\Delta V}{\Delta t}$$

where:

I = AGC pullup current for the initial 10ms ($67.5\mu\text{A}$)

C_{AGC} = AGC capacitor value

Δt = droop recovery time

ΔV = droop voltage

For example, if user desires $\Delta t = 10\text{ms}$ and chooses a $4.7\mu\text{F}$ C_{AGC} , then the allowable droop is about 144mV. Using the same equation with 200nA worst case pin leakage and assuming $1\mu\text{A}$ of capacitor leakage in the same direction, the maximum allowable Δt (shutdown time) is about 0.56s for droop recovery in 10ms.

150MHz Receiver/Decoder Application

Figure 7a illustrates a typical application for the MICRF004 VHF Receiver IC. This receiver operates continuously (not duty cycled) in sweep mode, and features 6-bit address decoding and two output code bits.

Operation in this example is at 150MHz, and may be customized by selection of the appropriate frequency reference (CR1), and adjustment of the antenna length. The value of C4 would also change if the optional input filter is used. Changes from the 1kb/s data rate may require a change in the value of R1. A bill of materials accompanies the schematic.

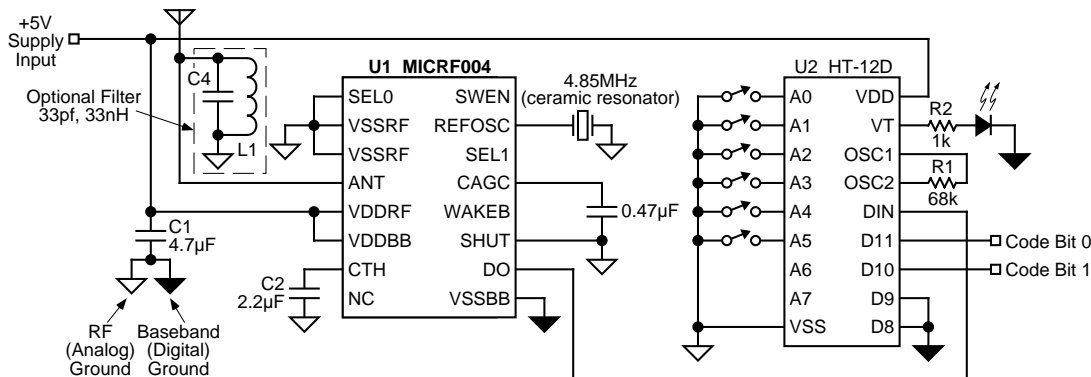

Figure 7a. 150MHz, 1kb/s On-Off Keyed Receiver/Decoder

Item	Part Number	Manufacturer	Description
U1	MICRF004	Micrel	UHF receiver
U2	HT-12D	Holtek	logic decoder
CR1	CSA4.65MG	Murata	4.65MHz ceramic resonator
D1	SSF-LX100LID	Lumex	red LED
R1			68k 1/4W 5%
R2		Bourns	1k 1/4W 5%
C1		Panasonic	4.7µF dipped tantalum capacitor
C3		Panasonic	0.47µF dipped tantalum capacitor
C2		Panasonic	2.2µF dipped tantalum capacitor
C4		Panasonic	8.2pF COG ceramic capacitor

Figure 7b. Bill of Material

Vendor	Telephone	FAX
Bourns	(909) 781-5500	(909) 781-5273
Holtek	(408) 894-9046	(408) 894-0838
Lumex	(800) 278-5666	(847) 359-8904
Murata	(800) 241-6574	(770) 436-3030
Panasonic	(201) 348-7000	(201) 348-8164

Figure 7c. Component Vendors

Package Information

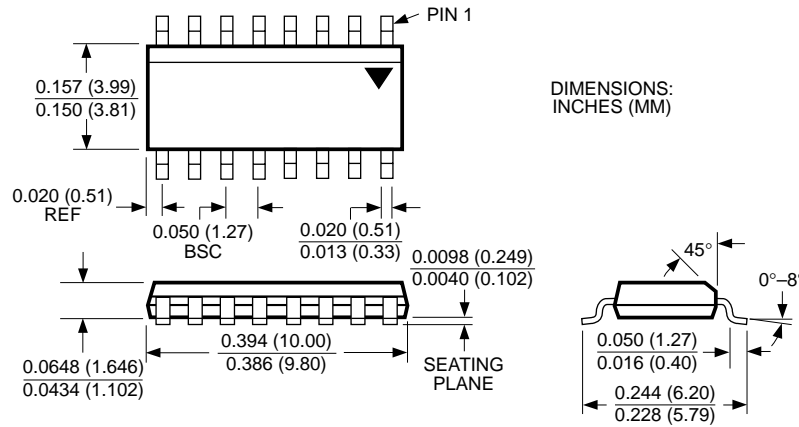

16-Lead SOP (M)

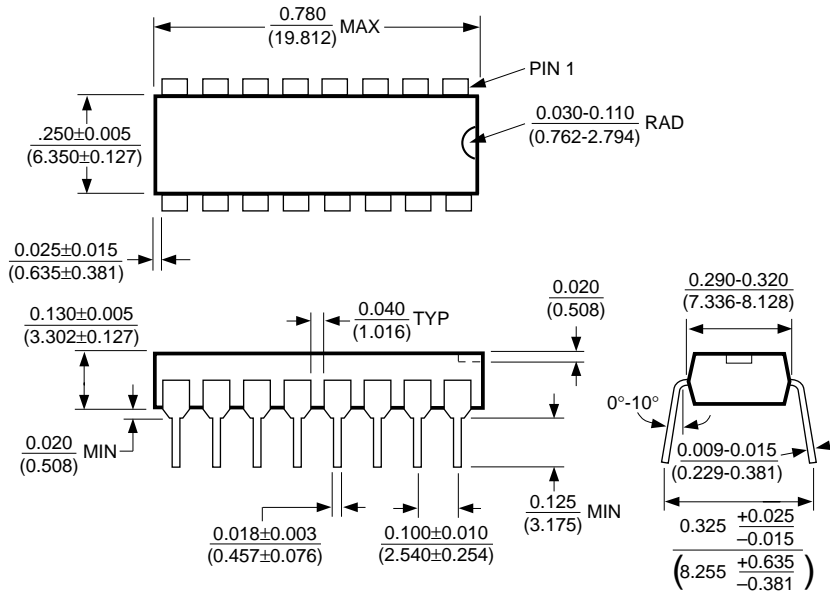

16-Pin DIP (N)

MICREL INC. 1849 FORTUNE DRIVE SAN JOSE, CA 95131 USA

TEL + 1 (408) 944-0800 FAX + 1 (408) 944-0970 WEB <http://www.micrel.com>

This information is believed to be accurate and reliable, however no responsibility is assumed by Micrel for its use nor for any infringement of patents or other rights of third parties resulting from its use. No license is granted by implication or otherwise under any patent or patent right of Micrel Inc.

© 1999 Micrel Incorporated