

LM103

Reference Diode

The LM103 is a two-terminal monolithic reference diode electrically equivalent to a breakdown diode. The device makes use of the reverse punch-through of double-diffused transistors, combined with active circuitry, to produce a breakdown characteristics which is ten times sharper than single-junction zener diodes at low voltages. Breakdown voltages from 3.0V to 3.9V are available; and, although the design is optimized for operation between 100 μ A and 1 mA, it is completely specified from 10 μ A to 10 mA.

Rochester Electronics Manufactured Components

Rochester branded components are manufactured using either die/wafers purchased from the original suppliers or Rochester wafers recreated from the original IP. All recreations are done with the approval of the OCM.

Parts are tested using original factory test programs or Rochester developed test solutions to guarantee product meets or exceeds the OCM data sheet.

Quality Overview

- ISO-9001
- AS9120 certification
- Qualified Manufacturers List (QML) MIL-PRF-38535
 - Class Q Military
 - Class V Space Level
- Qualified Suppliers List of Distributors (QSLD)
 - Rochester is a critical supplier to DLA and meets all industry and DLA standards.

Rochester Electronics, LLC is committed to supplying products that satisfy customer expectations for quality and are equal to those originally supplied by industry manufacturers.

The original manufacturer's datasheet accompanying this document reflects the performance and specifications of the Rochester manufactured version of this device. Rochester Electronics guarantees the performance of its semiconductor products to the original OEM specifications. 'Typical' values are for reference purposes only. Certain minimum or maximum ratings may be based on product characterization, design, simulation, or sample testing.

LM103 Reference Diode**

General Description

The LM103 is a two-terminal monolithic reference diode electrically equivalent to a breakdown diode. The device makes use of the reverse punch-through of double-diffused transistors, combined with active circuitry, to produce a breakdown characteristic which is ten times sharper than single-junction zener diodes at low voltages. Breakdown voltages from 3.0V to 3.9V are available; and, although the design is optimized for operation between 100 μ A and 1 mA, it is completely specified from 10 μ A to 10 mA.

- Performance guaranteed over full military temperature range
- Planar, passivated junctions for stable operation
- Low capacitance.

The LM103, packaged in a hermetically sealed, modified TO-46 header is useful in a wide range of circuit applications from level shifting to simple voltage regulation. It can also be employed with operational amplifiers in producing break-points to generate nonlinear transfer functions. Finally, its unique characteristics recommend it as a reference element in low voltage power supplies with input voltages down to 4V.

Features

- Exceptionally sharp breakdown
- Low dynamic impedance from 10 μ A to 10 mA

Schematic and Connection Diagrams

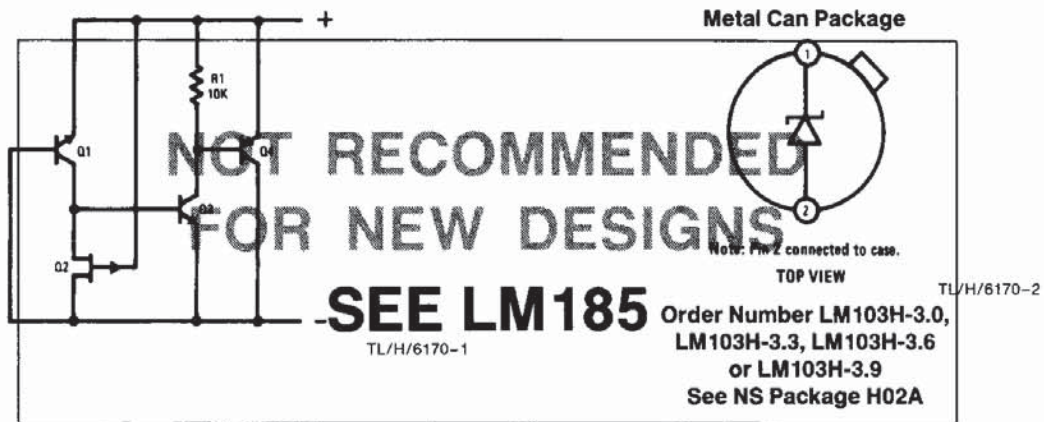

Typical Applications

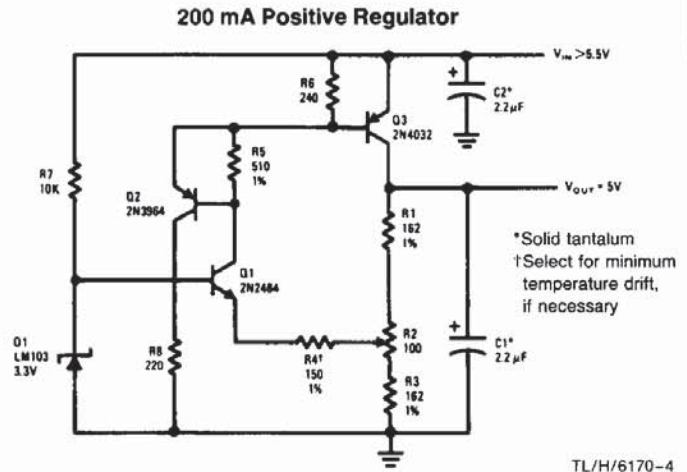
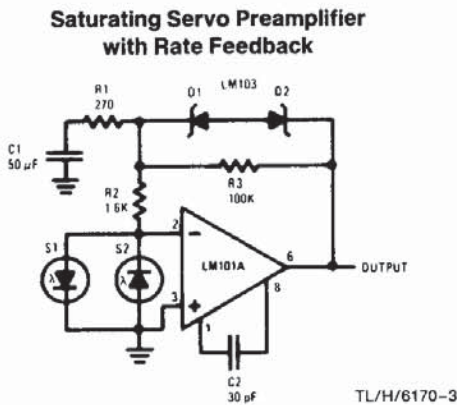

**Covered by U.S. Patent Number 3,571,630