

Contents

1 Introduction 1

2 Signals and Connections 5

3 Specifications 13

4 Pin-Out and Package Information 91

Contact Information Last Page

1 Introduction

Motorola's i.MX family of microprocessors has demonstrated leadership in the portable handheld market. Continuing this legacy, the i.MX series provides a leap in performance with an ARM9™ microprocessor core and highly integrated system functions. The i.MX products specifically address the requirements of the personal, portable product market by providing intelligent integrated peripherals, an advanced processor core, and power management capabilities.

The new MC9328MX1 features the advanced and power-efficient ARM920T™ core that operates at speeds up to 200 MHz. Integrated modules, which include an LCD controller, static RAM, USB support, an A/D converter (with touch panel control), and an MMC/SD host controller, support a suite of peripherals to enhance any product seeking to provide a rich multimedia experience. In addition, the MC9328MX1 is the first Bluetooth™ technology-ready applications processor. It is packaged in a 256-pin Mold Array Process-Ball Grid Array (MAPBGA). Figure 1 on page 1 shows the functional block diagram of the MC9328MX1.

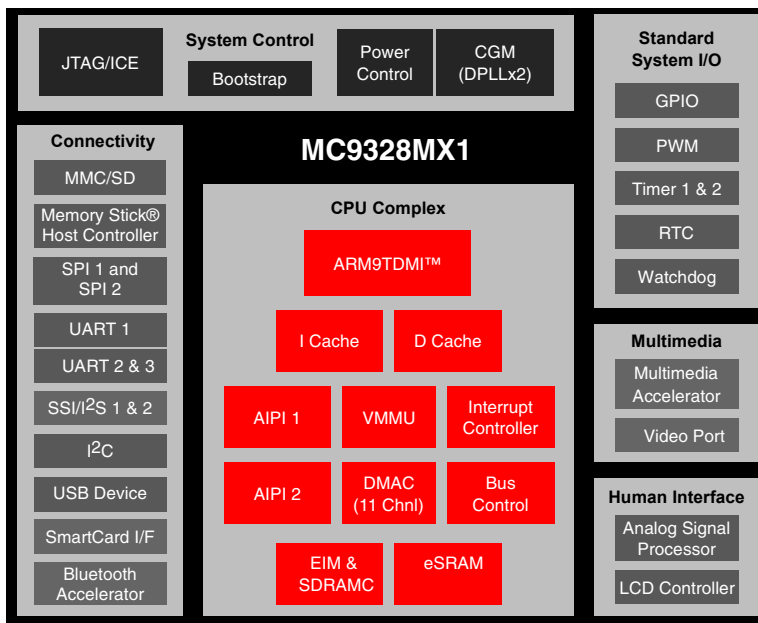

Figure 1. MC9328MX1 Functional Block Diagram

1.1 Conventions

This document uses the following conventions:

- $\overline{\text{OVERBAR}}$ is used to indicate a signal that is active when pulled low: for example, $\overline{\text{RESET}}$.
- *Logic level one* is a voltage that corresponds to Boolean true (1) state.
- *Logic level zero* is a voltage that corresponds to Boolean false (0) state.
- To *set* a bit or bits means to establish logic level one.
- To *clear* a bit or bits means to establish logic level zero.
- A *signal* is an electronic construct whose state conveys or changes in state convey information.
- A *pin* is an external physical connection. The same pin can be used to connect a number of signals.
- *Asserted* means that a discrete signal is in active logic state.
 - *Active low* signals change from logic level one to logic level zero.
 - *Active high* signals change from logic level zero to logic level one.
- *Negated* means that an asserted discrete signal changes logic state.
 - *Active low* signals change from logic level zero to logic level one.
 - *Active high* signals change from logic level one to logic level zero.
- LSB means *least significant bit* or *bits*, and MSB means *most significant bit* or *bits*. References to low and high bytes or words are spelled out.
- Numbers preceded by a percent sign (%) are binary. Numbers preceded by a dollar sign (\$) or $0x$ are hexadecimal.

1.2 Features

To support a wide variety of applications, the MC9328MX1 provides a robust array of features, including the following:

- ARM920T Microprocessor Core
- AHB to IP Bus Interfaces (APIs)
- External Interface Module (EIM)
- SDRAM Controller (SDRAMC)
- DPLL Clock and Power Control Module
- Three Universal Asynchronous Receiver/Transmitters (UART 1 UART 2 and UART 3)
- Two Serial Peripheral Interfaces (SPI)
- Two General-Purpose 32-bit Counters/Timers
- Watchdog Timer
- Real-Time Clock/Sampling Timer (RTC)
- LCD Controller (LDC)
- Pulse-Width Modulation (PWM) Module
- Universal Serial Bus (USB) Device
- Multimedia Card and Secure Digital (MMC/SD) Host Controller Module
- Memory Stick® Host Controller (MSHC)

- SmartCard Interface Module (SIM)
- Direct Memory Access Controller (DMAC)
- Two Synchronous Serial Interfaces and Inter-IC Sound (SSI 1 and SSI 2/I²S) Module
- Inter-IC (I²C) Bus Module
- Video Port
- General-Purpose I/O (GPIO) Ports
- Bootstrap Mode
- Analog Signal Processing (ASP) Module
- Bluetooth Accelerator (BTA)
- Multimedia Accelerator (MMA)
- 256-pin MAPBGA Package

1.3 Target Applications

The MC9328MX1 is targeted for advanced information appliances, smart phones, Web browsers, digital MP3 audio players, handheld computers based on the popular Palm OS platform, and messaging applications such as Motorola's wireless cellular products, including the AccompliTM 008 GSM/GPRS interactive communicator.

1.4 Document Revision History

The following table provides revision history for this release. This history includes technical content revisions only and not stylistic or grammatical changes.

Table 1. MC9328MX1 Data Sheet Revision History Rev. 3.0

Revision Location	Revision
Throughout data sheet	Changed all references to USB from self-powered only to self-powered and bus-powered. Changed all references to DragonBall to i.MX.
SDRAM timing in Section 3.17, "SDRAM Memory Controller," on page 71	SDRAM clock cycle time changed from 11.4 ns to 10.4 ns at 1.8V in all three tables.
Maximum ratings Table 4 on page 13	Change to maximum operation temperature range from 70°C to 85°C in table and throughout data sheet.
32 k/16 MHz Osc signal timing. Table 8 on page 15	Changed EXTAL32k input jitter (peak to peak) data/
Section Section 3.8.2, "DTACK Signal Timing," on page 23	Updated DTACK waveform and timing tables and figures.
Signals Table 3	Corrected MS_CLKI and MS_CLKO pin descriptions. Removed descriptions of SVDD and SGND.
Section 3.8.3, "EIM External Bus Timing," on page 28	Clarified signal naming on all waveform diagrams
Specification updates	Max temperature ratings and part numbers were updated.

1.5 Product Documentation

The following documents are required for a complete description of the MC9328MX1 and are necessary to design properly with the device. Especially for those not familiar with the ARM920T processor or previous DragonBall products, the following documents are helpful when used in conjunction with this manual.

ARM Architecture Reference Manual (ARM Ltd., order number ARM DDI 0100)

ARM9DT1 Data Sheet Manual (ARM Ltd., order number ARM DDI 0029)

ARM Technical Reference Manual (ARM Ltd., order number ARM DDI 0151C)

EMT9 Technical Reference Manual (ARM Ltd., order number DDI O157E)

MC9328MX1 Product Brief (order number MC9328MX1P/D)

MC9328MX1S Reference Manual (order number MC9328MX1SRM/D)

MC68VZ328 Product Brief (order number MC68VZ328P/D)

MC68VZ328 User's Manual (order number MC68VZ328UM/D)

MC68VZ328 User's Manual Addendum (order number MC68VZ328UMAD/D)

MC68SZ328 Product Brief (order number MC68SZ328P/D)

MC68SZ328 User's Manual (order number MC68SZ328UM/D)

The Motorola manuals are available on the Motorola Semiconductors Web site at <http://www.motorola.com/semiconductors>. These documents may be downloaded directly from the Motorola Web site, or printed versions may be ordered. The ARM documentation is available from <http://www.arm.com>.

1.6 Ordering Information

Table 2 provides ordering information for the 256-lead mold array process ball grid array (MAPBGA) package.

Table 2. MC9328MX1 Ordering Information

Package Type	Frequency	Temperature	Solderball Type	Order Number
256-lead MAPBGA	200 MHz	0°C to 70°C	Standard	MC9328MX1VH20(R2)
256-lead MAPBGA	200 MHz	0°C to 70°C	Pb-free	MC9328MX1VM20(R2)
256-lead MAPBGA	200 MHz	-30°C to 70°C	Standard	MC9328MX1DVH20(R2)
256-lead MAPBGA	200 MHz	-30°C to 70°C	Pb-free	MC9328MX1DVM20(R2)
256-lead MAPBGA	150 MHz	-40°C to 85°C	Standard	MC9328MX1CVH15(R2)
256-lead MAPBGA	150 MHz	-40°C to 85°C	Pb-free	MC9328MX1CVM15(R2)

2 Signals and Connections

Table 3 identifies and describes the MC9328MX1 signals that are assigned to package pins. The signals are grouped by the internal module that they are connected to.

Table 3. Signal Names and Descriptions

Signal Name	Function/Notes
External Bus/Chip Select (EIM)	
A [24:0]	Address bus signals
D [31:0]	Data bus signals
$\overline{EB0}$	MSB Byte Strobe—Active low external enable byte signal that controls D [31:24]
$\overline{EB1}$	Byte Strobe—Active low external enable byte signal that controls D [23:16]
$\overline{EB2}$	Byte Strobe—Active low external enable byte signal that controls D [15:8]
$\overline{EB3}$	LSB Byte Strobe—Active low external enable byte signal that controls D [7:0]
\overline{OE}	Memory Output Enable—Active low output enables external data bus
\overline{CS} [5:0]	Chip Select—The chip select signals \overline{CS} [3:2] are multiplexed with \overline{CSD} [1:0] and are selected by the Function Multiplexing Control Register (FMCR). By default \overline{CSD} [1:0] is selected.
\overline{ECB}	Active low input signal sent by flash device to the EIM whenever the flash device must terminate an on-going burst sequence and initiate a new (long first access) burst sequence.
\overline{LBA}	Active low signal sent by flash device causing the external burst device to latch the starting burst address.
\overline{BCLK}	Clock signal sent to external synchronous memories (such as burst flash) during burst mode.
\overline{RW}	\overline{RW} signal—Indicates whether external access is a read (high) or write (low) cycle. Used as a \overline{WE} input signal by external DRAM.
Bootstrap	
BOOT [3:0]	System Boot Mode Select—The operational system boot mode of the MC9328MX1 upon system reset is determined by the settings of these pins.
SDRAM Controller	
SDBA [4:0]	SDRAM/SyncFlash non-interleave mode bank address multiplexed with address signals A [15:11]. These signals are logically equivalent to core address p_addr [25:21] in SDRAM/SyncFlash cycles.
SDIBA [3:0]	SDRAM/SyncFlash interleave addressing mode bank address multiplexed with address signals A [19:16]. These signals are logically equivalent to core address p_addr [12:9] in SDRAM/SyncFlash cycles.
MA [11:10]	SDRAM address signals

Table 3. Signal Names and Descriptions (Continued)

Signal Name	Function/Notes
MA [9:0]	SDRAM address signals which are multiplex with address signals A [10:1]. MA [9:0] are selected on SDRAM/SyncFlash cycles.
DQM [3:0]	SDRAM data enable
$\overline{\text{CSD0}}$	SDRAM/SyncFlash Chip Select signal which is multiplexed with the $\overline{\text{CS2}}$ signal. These two signals are selectable by programming the system control register.
$\overline{\text{CSD1}}$	SDRAM/SyncFlash Chip Select signal which is multiplex with $\overline{\text{CS3}}$ signal. These two signals are selectable by programming the system control register. By default, $\overline{\text{CSD1}}$ is selected, so it can be used as SyncFlash boot chip select by properly configuring BOOT [3:0] input pins.
$\overline{\text{RAS}}$	SDRAM/SyncFlash Row Address Select signal
$\overline{\text{CAS}}$	SDRAM/SyncFlash Column Address Select signal
$\overline{\text{SDWE}}$	SDRAM/SyncFlash Write Enable signal
SDCKE0	SDRAM/SyncFlash Clock Enable 0
SDCKE1	SDRAM/SyncFlash Clock Enable 1
SDCLK	SDRAM/SyncFlash Clock
$\overline{\text{RESET_SF}}$	SyncFlash Reset
Clocks and Resets	
EXTAL16M	Crystal input (4 MHz to 16 MHz), or a 16 MHz oscillator input when internal oscillator circuit is shut down.
XTAL16M	Crystal output
EXTAL32K	32 kHz crystal input
XTAL32K	32 kHz crystal output
CLKO	Clock Out signal selected from internal clock signals. Please refer to clock controller for internal clock selection.
$\overline{\text{RESET_IN}}$	Master Reset—External active low Schmitt trigger input signal. When this signal goes active, all modules (except the reset module and the clock control module) are reset.
$\overline{\text{RESET_OUT}}$	Reset Out—Internal active low output signal from the Watchdog Timer module and is asserted from the following sources: Power-on reset, External reset ($\overline{\text{RESET_IN}}$), and Watchdog time-out.
POR	Power On Reset—Internal active high Schmitt trigger input signal. The POR signal is normally generated by an external RC circuit designed to detect a power-up event.
JTAG	
$\overline{\text{TRST}}$	Test Reset Pin—External active low signal used to asynchronously initialize the JTAG controller.
$\overline{\text{TDO}}$	Serial Output for test instructions and data. Changes on the falling edge of TCK.

Table 3. Signal Names and Descriptions (Continued)

Signal Name	Function/Notes
TDI	Serial Input for test instructions and data. Sampled on the rising edge of TCK.
TCK	Test Clock to synchronize test logic and control register access through the JTAG port.
TMS	Test Mode Select to sequence the JTAG test controller's state machine. Sampled on the rising edge of TCK.
System	
BIG_ENDIAN	BIG_ENDIAN—This signal determines the memory endian configuration. BIG_ENDIAN is a static pin to inner module. If the pin is driven logic-high the memory system is configured into big endian. If it is driven logic-low the memory system is configured into little endian. The pin is not supposed to be changed on the fly.
ETM	
ETMTRACESYNC	ETM sync signal which is multiplexed with A24. ETMTRACESYNC is selected in ETM mode.
ETMTRACECLK	ETM clock signal which is multiplexed with A23. ETMTRACECLK is selected in ETM mode.
ETMPIPESTAT [2:0]	ETM status signals which are multiplex with A [22:20]. ETMPIPESTAT [2:0] are selected in ETM mode.
ETMTRACEPKT [7:0]	ETM packet signals which are multiplex with \overline{ECB} , \overline{LBA} , \overline{BCLK} , PA17, A [19:16]. ETMTRACEPKT [7:0] are selected in ETM mode.
CMOS Sensor Interface	
CSI_D [7:0]	Sensor port data
CSI_MCLK	Sensor port master clock
CSI_VSYNC	Sensor port vertical sync
CSI_HSYNC	Sensor port horizontal sync
CSI_PIXCLK	Sensor port data latch clock
LCD Controller	
LD [15:0]	LCD Data Bus—All LCD signals are driven low after reset and when LCD is off.
FLM/VSYNC	Frame Sync or Vsync—This signal also serves as the clock signal output for gate driver (dedicated signal SPS for Sharp panel HR-TFT).
LP/HSYNC	Line Pulse or H Sync
LSCLK	Shift Clock
ACD/OE	Alternate Crystal Direction/Output Enable
CONTRAST	This signal is used to control the LCD bias voltage as contrast control.
SPL_SPR	Program horizontal scan direction (Sharp panel dedicated signal).

Table 3. Signal Names and Descriptions (Continued)

Signal Name	Function/Notes
PS	Control signal output for source driver (Sharp panel dedicated signal).
CLS	Start signal output for gate driver. This signal is invert version of PS (Sharp panel dedicated signal).
REV	Signal for common electrode driving signal preparation (Sharp panel dedicated signal).
SIM	
SIM_CLK	SIM Clock
SIM_RST	SIM Reset
SIM_RX	Receive Data
SIM_TX	Transmit Data
SIM_PD	Presence Detect Schmitt trigger input
SIM_SVEN	SIM Vdd Enable
SPI	
SPI1_MOSI	Master Out/Slave In
SPI1_MISO	Slave In/Master Out
SPI1_ \overline{SS}	Slave Select (Selectable polarity)
SPI1_SCLK	Serial Clock
SPI1_ $\overline{SPI_RDY}$	Serial Data Ready
SPI2_TXD	SPI2 Master TxData Output—This signal is multiplexed with a GPI/O pin however it does show up as a primary or alternative signal in the signal multiplex scheme table. Refer to Chapter 16, “Serial Peripheral Interface Modules (SPI 1 and SPI 2),” and Chapter 29, “GPIO Module and I/O Multiplexer (IOMUX),” for information on how to bring this signal to the assigned pin.
SPI2_RXD	SPI2 master RxData input—This signal is multiplexed with a GPI/O pin however it does show up as a primary or alternative signal in the signal multiplex scheme table. Refer to Chapter 16, “Serial Peripheral Interface Modules (SPI 1 and SPI 2),” and Chapter 29, “GPIO Module and I/O Multiplexer (IOMUX),” for information on how to bring this signal to the assigned pin.
SPI2_ \overline{SS}	SPI2 Slave Select—This signal is multiplexed with a GPI/O pin, however it does show up as a primary or alternative signal in the signal multiplex scheme table. Refer to Chapter 16, “Serial Peripheral Interface Modules (SPI 1 and SPI 2),” and Chapter 29, “GPIO Module and I/O Multiplexer (IOMUX),” for information on how to bring this signal to the assigned pin.
SPI2_SCLK	SPI2 Serial Clock—This signal is multiplexed with a GPI/O pin however it does show up as a primary or alternative signal in the signal multiplex scheme table. Refer to Chapter 16, “Serial Peripheral Interface Modules (SPI 1 and SPI 2),” and Chapter 29, “GPIO Module and I/O Multiplexer (IOMUX),” for information on how to bring this signal to the assigned pin.

Table 3. Signal Names and Descriptions (Continued)

Signal Name	Function/Notes
General Purpose Timers	
TIN	Timer Input Capture or Timer Input Clock—The signal on this input is applied to both timers simultaneously.
TMR2OUT	Timer 2 Output
USB Device	
USBD_VMO	USB Minus Output
USBD_VPO	USB Plus Output
USBD_VM	USB Minus Input
USBD_VP	USB Plus Input
USBD_SUSPND	USB Suspend Output
USBD_RCV	USB RxD
$\overline{\text{USBD_OE}}$	USB $\overline{\text{OE}}$
USBD_AFE	USB Analog Front End Enable
Secure Digital Interface	
SD_CMD	SD Command—If the system designer does not want to make use of the internal pull-up, via the Pull-up enable register, a 4.7K–69K external pull up resistor must be added.
SD_CLK	MMC Output Clock
SD_DAT [3:0]	Data—If the system designer does not want to make use of the internal pull-up, via the Pull-up enable register, a 50 K–69K external pull up resistor must be added.
Memory Stick Interface	
MS_BS	Memory Stick Bus State (Output)—Serial bus control signal
MS_SDIO	Memory Stick Serial Data (Input/Output)
MS_SCLKO	Memory Stick Serial Clock (Output)—Serial Protocol clock output
MS_SCLKI	Memory Stick External Clock (Input)—Test clock input pin for SCLK divider. This pin is only for test purposes, not for use in application mode.
MS_PI0	General purpose Input0—Can be used for Memory Stick Insertion/Extraction detect
MS_PI1	General purpose Input1—Can be used for Memory Stick Insertion/Extraction detect
UARTs – IrDA/Auto-Bauding	
UART1_RXD	Receive Data
UART1_TXD	Transmit Data

Table 3. Signal Names and Descriptions (Continued)

Signal Name	Function/Notes
UART1_RTS	Request to Send
UART1_CTS	Clear to Send
UART2_RXD	Receive Data
UART2_TXD	Transmit Data
UART2_RTS	Request to Send
UART2_CTS	Clear to Send
UART2_DSR	Data Set Ready
UART2_RI	Ring Indicator
UART2_DCD	Data Carrier Detect
UART2_DTR	Data Terminal Ready
UART3_RXD	Receive Data
UART3_TXD	Transmit Data
UART3_RTS	Request to Send
UART3_CTS	Clear to Send
UART3_DSR	Data Set Ready
UART3_RI	Ring Indicator
UART3_DCD	Data Carrier Detect
UART3_DTR	Data Terminal Ready
Serial Audio Ports – SSI (configurable to I2S protocol)	
SSI1_TXDAT	TxD
SSI1_RXDAT	RxD
SSI1_TXCLK	Transmit Serial Clock
SSI1_RXCLK	Receive Serial Clock
SSI1_TXFS	Transmit Frame Sync
SSI1_RXFS	Receive Frame Sync
SSI2_TXDAT	TxD
SSI2_RXDAT	RxD
SSI2_TXCLK	Transmit Serial Clock
SSI2_RXCLK	Receive Serial Clock

Table 3. Signal Names and Descriptions (Continued)

Signal Name	Function/Notes
SSI2_TXFS	Transmit Frame Sync
SSI2_RXFS	Receive Frame Sync
I²C	
I2C_SCL	I ² C Clock
I2C_SDA	I ² C Data
PWM	
PWMO	PWM Output
ASP	
UIN	Positive U analog input (for low voltage, temperature measurement)
UIP	Negative U analog input (for low voltage, temperature measurement)
PX1	Positive pen-X analog input
PY1	Positive pen-Y analog input
PX2	Negative pen-X analog input
PY2	Negative pen-Y analog input
R1A	Positive resistance input (a)
R1B	Positive resistance input (b)
R2A	Negative resistance input (a)
R2B	Negative resistance input (b)
RVP	Positive reference for pen ADC
RVM	Negative reference for pen ADC
AVDD	Analog power supply
AGND	Analog ground
BlueTooth	
BT1	I/O clock signal
BT2	Output
BT3	Input
BT4	Input
BT5	Output

Table 3. Signal Names and Descriptions (Continued)

Signal Name	Function/Notes
BT6	Output
BT7	Output
BT8	Output
BT9	Output
BT10	Output
BT11	Output
BT12	Output
BT13	Output
TRISTATE	Sets all I/O pins to tristate; Can be used for flash loading and is pulled low for normal operations.
BTRF VDD	Power supply from external BT RFIC
BTRF GND	Ground from external BT RFIC
Noisy Supply Pins	
NVDD	Noisy Supply for the I/O pins
NVSS	Noisy Ground for the I/O pins
Supply Pins – Analog Modules	
AVDD	Supply for analog blocks
AVSS	Quiet GND for analog blocks
Internal Power Supply	
QVDD	Power supply pins for silicon internal circuitry
QVSS	GND pins for silicon internal circuitry

3 Specifications

This section contains the electrical specifications and timing diagrams for the MC9328MX1 processor.

3.1 Maximum Ratings

Table 4 provides information on maximum ratings.

Table 4. Maximum Ratings

Rating	Symbol	Minimum	Maximum	Unit
Supply voltage	V_{dd}	-0.3	3.3	V
Maximum operating temperature range MC9328MX1VH20/MC9328MX1VM20	T_A	0	70	°C
Maximum operating temperature range MC9328MX1DVH20/MC9328MX1DVM20	T_A	-30	70	°C
Maximum operating temperature range MC9328MX1CVH15/MC9328MX1CVM15	T_A	-40	85	°C
ESD at human body model (HBM)	VESD_HBM	–	2000	V
ESD at machine model (MM)	VESD_MM	–	100	V
Latch-up current	ILatchup	–	200	mA
Storage temperature	Test	-55	150	°C
Power Consumption	Pmax	800 ¹	1300 ²	mW

1. A typical application with 30 pads simultaneously switching assumes the GPIO toggling and instruction fetches from the ARM core—that is, 7x GPIO, 15x Data bus, and 8x Address bus.
2. A worst-case application with 70 pads simultaneously switching assumes the GPIO toggling and instruction fetches from the ARM core—that is, 32x GPIO, 30x Data bus, 8x Address bus. These calculations are based on the core running its heaviest OS application at 200MHz, and where the whole image is running out of SDRAM. QVDD at 2.0V, NVDD and AVDD at 3.3V, therefore, 180mA is the worst measurement recorded in the factory environment, max 5mA is consumed for OSC pads, with each toggle GPIO consuming 4mA.

3.2 Recommended Operating Range

Table 5 provides the recommended operating ranges for the supply voltages. The MC9328MX1 processor has multiple pairs of VDD and VSS power supply and return pins. QVDD and QVSS pins are used for internal logic. All other VDD and VSS pins are for the I/O pads voltage supply, and each pair of VDD and VSS provides power to the enclosed I/O pads. This design allows different peripheral supply voltage levels in a system.

Because AVDD pins are supply voltages to the analog pads, it is recommended to isolate and noise-filter the AVDD pins from other VDD pins.

BTRFVDD is the supply voltage for the Bluetooth interface signals. It is quite sensitive to the data transmit/receive accuracy. Please refer to Bluetooth RF spec for special handling. If Bluetooth is not used in the system, these Bluetooth pins can be used as general purpose I/O pins and BTRFVDD can be used as other NVDD pins.

Specifications

For more information about I/O pads grouping per VDD, please refer to Table 3 on page 5.

Table 5. Recommended Operating Range

Rating	Symbol	Minimum	Maximum	Unit
I/O supply voltage, MSHC, SPI, BTA, USBd, LCD and CSI are only 3V interface	NVDD	2.70	3.30	V
I/O supply voltage	NVDD	1.70	3.30	V
Internal supply voltage (Core = 150 MHz)	QVDD	1.70	1.90	V
Internal supply voltage (Core = 200 MHz)	QVDD	1.80	2.00	V
Analog supply voltage	AVDD	1.70	3.30	V
Bluetooth I/O voltage (Bluetooth)	BTRFVDD ₁	1.70	3.10	V
Bluetooth I/O voltage (Non Bluetooth applications)	BTRFVDD ₂	1.70	3.30	V

3.3 DC Electrical Characteristics

Table 6 contains both maximum and minimum DC characteristics of the MC9328MX1.

Table 6. Maximum and Minimum DC Characteristics

Number or Symbol	Parameter	Minimum	Typical	Maximum	Unit
I _{op}	Full running operating current at 1.8V for QVDD, 3.3V for NVDD/AVDD (Core = 96 MHz, System = 96 MHz, MPEG4 decoding playback from external memory card to both external SSI audio decoder and TFT display panel, and OS with MMU enabled memory system is running on external SDRAM) <i>Please refer to application note: AN2537, Power Performance of MC9328MX1.</i>	–	QVDD at 1.8v = 120mA; NVDD+AVDD at 3.0v = 30mA	–	mA
Sidd ₁	Standby current (QVDD = 1.8V, temp = 25°C)	–	25	–	μA
Sidd ₂	Standby current (QVDD = 1.8V, temp = 55°C)	–	45	–	μA
Sidd ₃	Standby current (QVDD = 2.0V, temp = 25°C)	–	35	–	μA
Sidd ₄	Standby current (QVDD = 2.0V, temp = 55°C)	–	60	–	μA
V _{IH}	Input high voltage	0.7V _{DD}	–	V _{DD} +0.2	V
V _{IL}	Input low voltage	–	–	0.4	V

Table 6. Maximum and Minimum DC Characteristics (Continued)

Number or Symbol	Parameter	Minimum	Typical	Maximum	Unit
V _{OH}	Output high voltage (I _{OH} = 2.0 mA)	0.7V _{DD}	–	V _{dd}	V
V _{OL}	Output low voltage (I _{OL} = -2.5 mA)	–	–	0.4	V
V _{it+}	Positive input threshold voltage, V _i = V _{ih}	–	–	1.126	V
V _{it-}	Negative input threshold voltage, V _i = V _{il}	0.640	–	–	V
V _{hys}	Hysteresis (V _{it+} – V _{it-}) = V _{ih}	–	0.3	–	–
I _{IL}	Input low leakage current (V _{IN} = GND, no pull-up or pull-down)	–	–	±1	μA
I _{IH}	Input high leakage current (V _{IN} = V _{DD} , no pull-up or pull-down)	–	–	±1	μA
I _{OH}	Output high current (V _{OH} = 0.8V _{DD} , V _{DD} = 1.8V)	–	–	4.0	mA
I _{OL}	Output low current (V _{OL} = 0.4V, V _{DD} = 1.8V)	–4.0	–	–	mA
I _{OZ}	Output leakage current (V _{out} = V _{DD} , output is tri-stated)	–	–	±5	μA
C _i	Input capacitance	–	–	5	pF
C _o	Output capacitance	–	–	5	pF

3.4 AC Electrical Characteristics

The AC characteristics consist of output delays, input setup and hold times, and signal skew times. All signals are specified relative to an appropriate edge of other signals. All timing specifications are specified at a system operating frequency from 0 MHz to 96 MHz (core operating frequency 150 MHz) with an operating supply voltage from V_{DD min} to V_{DD max} under an operating temperature from T_L to T_H. All timing is measured at 30 pF loading.

Table 7. Tri-State Signal Timing

Pin	Parameter	Minimum	Maximum	Unit
TRISTATE	Time from TRISTATE activate until I/O becomes Hi-Z	–	20.8	ns

Table 8. 32k/16M Oscillator Signal Timing

Parameter	Minimum	RMS	Maximum	Unit
EXTAL32k input jitter (peak to peak) for both System PLL and MCUPLL	–	5	20	ns

Specifications

Table 8. 32k/16M Oscillator Signal Timing (Continued)

Parameter	Minimum	RMS	Maximum	Unit
EXTAL32k input jitter (peak to peak) for MDCUPLL only	–	5	100	ns
EXTAL32k startup time	800	–	–	ms
EXTAL16M input jitter (peak to peak)	–	TBD	TBD	–
EXTAL16M startup time	TBD	–	–	–

Table 9. CLK0 Rise/Fall Time (at 30pF Loaded)

	Best Case	Typical	Worst Case	Units
Rise Time	0.80	1.00	1.40	ns
Fall Time	0.74	1.08	1.67	ns

3.5 Embedded Trace Macrocell

All registers in the ETM9 are programmed through a JTAG interface. The interface is an extension of the ARM920T processor's TAP controller, and is assigned scan chain 6. The scan chain consists of a 40-bit shift register comprised of the following:

- 32-bit data field
- 7-bit address field
- A read/write bit

The data to be written is scanned into the 32-bit data field, the address of the register into the 7-bit address field, and a 1 into the read/write bit.

A register is read by scanning its address into the address field and a 0 into the read/write bit. The 32-bit data field is ignored. A read or a write takes place when the TAP controller enters the UPDATE-DR state. The timing diagram for the ETM9 is shown in Figure 2. See Table 10 on page 17 for the ETM9 timing parameters used in Figure 2.

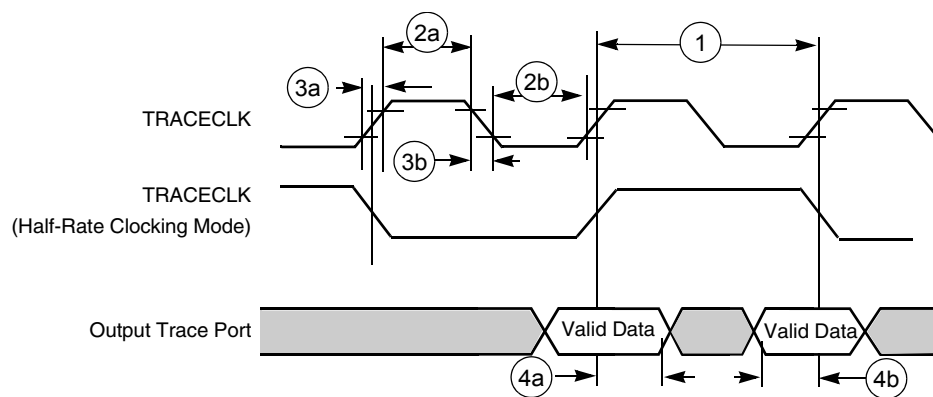

Figure 2. Trace Port Timing Diagram

Table 10. Trace Port Timing Diagram Parameter Table

Ref No.	Parameter	1.8V +/- 0.10V		3.0V +/- 0.30V		Unit
		Minimum	Maximum	Minimum	Maximum	
1	CLK frequency	0	85	0	100	MHz
2a	Clock high time	1.3	–	2	–	ns
2b	Clock low time	3	–	2	–	ns
3a	Clock rise time	–	4	–	3	ns
3b	Clock fall time	–	3	–	3	ns
4a	Output hold time	2.28	–	2	–	ns
4b	Output setup time	3.42	–	3	–	ns

Specifications

3.6 DPLL Timing Specifications

Parameters of the DPLL are given in Table 11. In this table, T_{ref} is a reference clock period after the pre-divider and T_{dck} is the output double clock period.

Table 11. DPLL Specifications

Parameter	Test Conditions	Minimum	Typical	Maximum	Unit
Reference clock freq range	Vcc = 1.8V	5	–	100	MHz
Pre-divider output clock freq range	Vcc = 1.8V	5	–	30	MHz
Double clock freq range	Vcc = 1.8V	80	–	220	MHz
Pre-divider factor (PD)	–	1	–	16	–
Total multiplication factor (MF)	Includes both integer and fractional parts	5	–	15	–
MF integer part	–	5	–	15	–
MF numerator	Should be less than the denominator	0	–	1022	–
MF denominator	–	1	–	1023	–
Pre-multiplier lock-in time	–	–	–	312.5	μsec
Freq lock-in time after full reset	FOL mode for non-integer MF (does not include pre-must lock-in time)	250	280 (56 μs)	300	T_{ref}
Freq lock-in time after partial reset	FOL mode for non-integer MF (does not include pre-multi lock-in time)	220	250 (~50 μs)	270	T_{ref}
Phase lock-in time after full reset	FPL mode and integer MF (does not include pre-multi lock-in time)	300	350 (70 μs)	400	T_{ref}
Phase lock-in time after partial reset	FPL mode and integer MF (does not include pre-multi lock-in time)	270	320 (64 μs)	370	T_{ref}
Freq jitter (p-p)	–	–	0.005 (0.01%)	0.01	$2 \cdot T_{dck}$
Phase jitter (p-p)	Integer MF, FPL mode, Vcc=1.8V	–	1.0 (10%)	1.5	ns
Power supply voltage	–	1.7	–	2.5	V
Power dissipation	FOL mode, integer MF, $f_{dck} = 200$ MHz, Vcc = 1.8V	–	–	4	mW

3.7 Reset Module

The timing relationships of the Reset module with the POR and $\overline{\text{RESET_IN}}$ are shown in Figure 3 and Figure 4. Be aware that NVDD must ramp up to at least 1.8V before QVDD is powered up to prevent forward biasing.

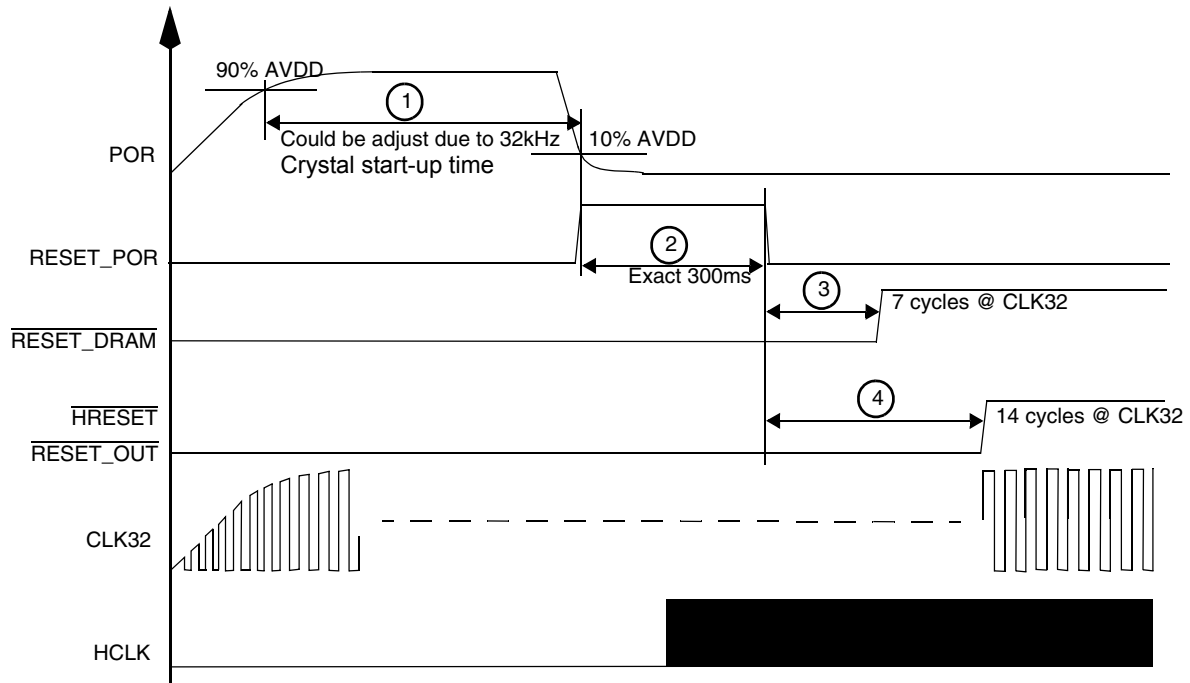

Figure 3. Timing Relationship with POR

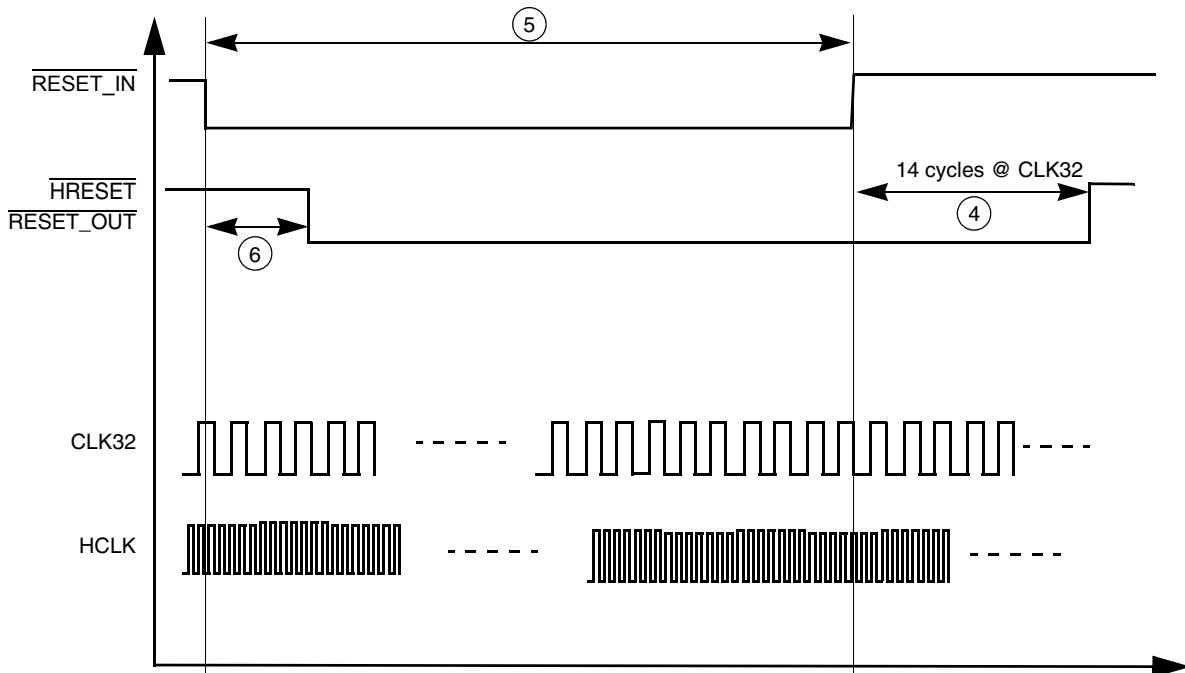

Figure 4. Timing Relationship with $\overline{\text{RESET_IN}}$

Specifications

Table 12. Reset Module Timing Parameter Table

Ref No.	Parameter	1.8V +/- 0.10V		3.0V +/- 0.30V		Unit
		Min	Max	Min	Max	
1	Width of input POWER_ON_RESET ¹	800	–	800	–	ns
2	Width of internal $\overline{\text{POWER_ON_RESET}}$ (9600 *CLK32 at 32 KHz)	300	300	300	300	ms
3	7K to 32K-cycle stretcher for SDRAM reset	7	7	7	7	Cycles of CLK32
4	14K to 32K-cycle stretcher for internal system reset $\overline{\text{HRESET}}$ and output reset at pin $\overline{\text{RESET_OUT}}$	14	14	14	14	Cycles of CLK32
5	Width of external hard-reset $\overline{\text{RESET_IN}}$	4	–	4	–	Cycles of CLK32
6	4K to 32K-cycle qualifier	4	4	4	4	Cycles of CLK32

¹ Timing waveforms shown are dependent on crystal start-up time. If a stable clock source is used instead of a crystal, the width of the POR should be ignored in calculating timing for the startup process.

3.8 External Interface Module

The External Interface Module (EIM) handles the interface to devices external to the MC9328MX1, including generation of chip-selects for external peripherals and memory. The timing diagram for the EIM is shown in Figure 5, and Table 13 defines the parameters of signals.

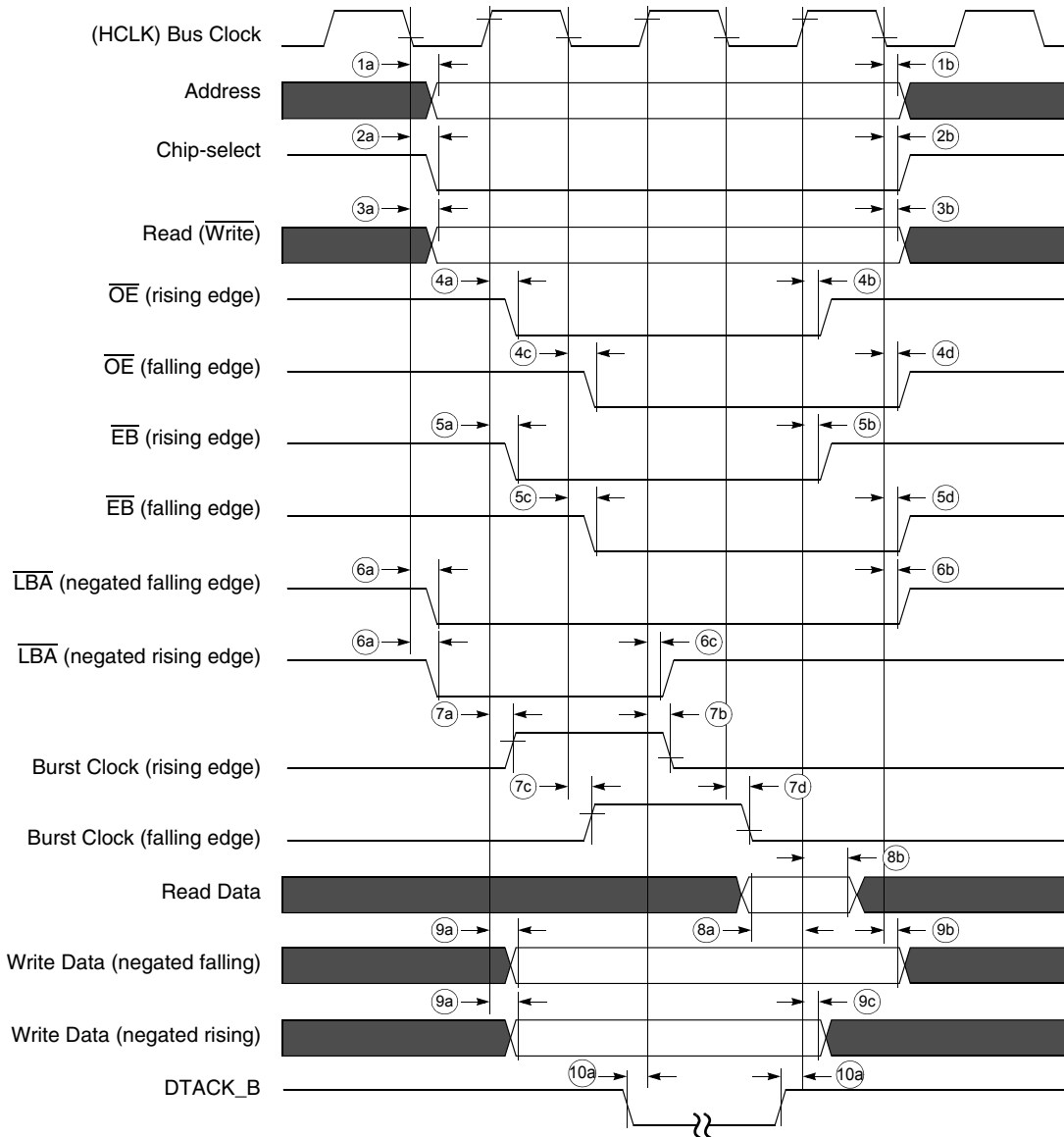

Figure 5. EIM Bus Timing Diagram

Table 13. EIM Bus Timing Parameter Table

Ref No.	Parameter	1.8 ± 0.10V			3.0 ± 0.3V			Unit
		Min	Typical	Max	Min	Typical	Max	
1a	Clock fall to address valid	2.48	3.31	9.11	2.4	3.2	8.8	ns
1b	Clock fall to address invalid	1.55	2.48	5.69	1.5	2.4	5.5	ns

Table 13. EIM Bus Timing Parameter Table (Continued)

Ref No.	Parameter	1.8 ± 0.10V			3.0 ± 0.3V			Unit
		Min	Typical	Max	Min	Typical	Max	
2a	Clock fall to chip-select valid	2.69	3.31	7.87	2.6	3.2	7.6	ns
2b	Clock fall to chip-select invalid	1.55	2.48	6.31	1.5	2.4	6.1	ns
3a	Clock fall to Read ($\overline{\text{Write}}$) Valid	1.35	2.79	6.52	1.3	2.7	6.3	ns
3b	Clock fall to Read ($\overline{\text{Write}}$) Invalid	1.86	2.59	6.11	1.8	2.5	5.9	ns
4a	Clock ¹ rise to Output Enable Valid	2.32	2.62	6.85	2.3	2.6	6.8	ns
4b	Clock ¹ rise to Output Enable Invalid	2.11	2.52	6.55	2.1	2.5	6.5	ns
4c	Clock ¹ fall to Output Enable Valid	2.38	2.69	7.04	2.3	2.6	6.8	ns
4d	Clock ¹ fall to Output Enable Invalid	2.17	2.59	6.73	2.1	2.5	6.5	ns
5a	Clock ¹ rise to Enable Bytes Valid	1.91	2.52	5.54	1.9	2.5	5.5	ns
5b	Clock ¹ rise to Enable Bytes Invalid	1.81	2.42	5.24	1.8	2.4	5.2	ns
5c	Clock ¹ fall to Enable Bytes Valid	1.97	2.59	5.69	1.9	2.5	5.5	ns
5d	Clock ¹ fall to Enable Bytes Invalid	1.76	2.48	5.38	1.7	2.4	5.2	ns
6a	Clock ¹ fall to Load Burst Address Valid	2.07	2.79	6.73	2.0	2.7	6.5	ns
6b	Clock ¹ fall to Load Burst Address Invalid	1.97	2.79	6.83	1.9	2.7	6.6	ns
6c	Clock ¹ rise to Load Burst Address Invalid	1.91	2.62	6.45	1.9	2.6	6.4	ns
7a	Clock ¹ rise to Burst Clock rise	1.61	2.62	5.64	1.6	2.6	5.6	ns
7b	Clock ¹ rise to Burst Clock fall	1.61	2.62	5.84	1.6	2.6	5.8	ns
7c	Clock ¹ fall to Burst Clock rise	1.55	2.48	5.59	1.5	2.4	5.4	ns
7d	Clock ¹ fall to Burst Clock fall	1.55	2.59	5.80	1.5	2.5	5.6	ns
8a	Read Data setup time	5.54	–	–	5.5	–	–	ns
8b	Read Data hold time	0	–	–	0	–	–	ns
9a	Clock ¹ rise to Write Data Valid	1.81	2.72	6.85	1.8	2.7	6.8	ns
9b	Clock ¹ fall to Write Data Invalid	1.45	2.48	5.69	1.4	2.4	5.5	ns
9c	Clock ¹ rise to Write Data Invalid	1.63	–	–	1.62	–	–	ns
10a	$\overline{\text{DTACK}}$ setup time	2.52	–	–	2.5	–	–	ns

1. Clock refers to the system clock signal, HCLK, generated from the System DPLL

3.8.1 $\overline{\text{DTACK}}$ Signal Description

The $\overline{\text{DTACK}}$ signal is the external input data acknowledge signal. When using the external $\overline{\text{DTACK}}$ signal as a data acknowledge signal, the bus time-out monitor generates a bus error when a bus cycle is not terminated by the external $\overline{\text{DTACK}}$ signal after 1022 HCLK counts have elapsed. Only CS5 group supports $\overline{\text{DTACK}}$ signal function when using the external $\overline{\text{DTACK}}$ signal for data acknowledgement.

3.8.2 $\overline{\text{DTACK}}$ Signal Timing

Figure 6 through Figure 9 show the access cycle timing used by chip-select 5. The signal values and units of measure for this figure are found in the associated tables.

3.8.2.1 $\overline{\text{DTACK}}$ READ Cycle without DMA

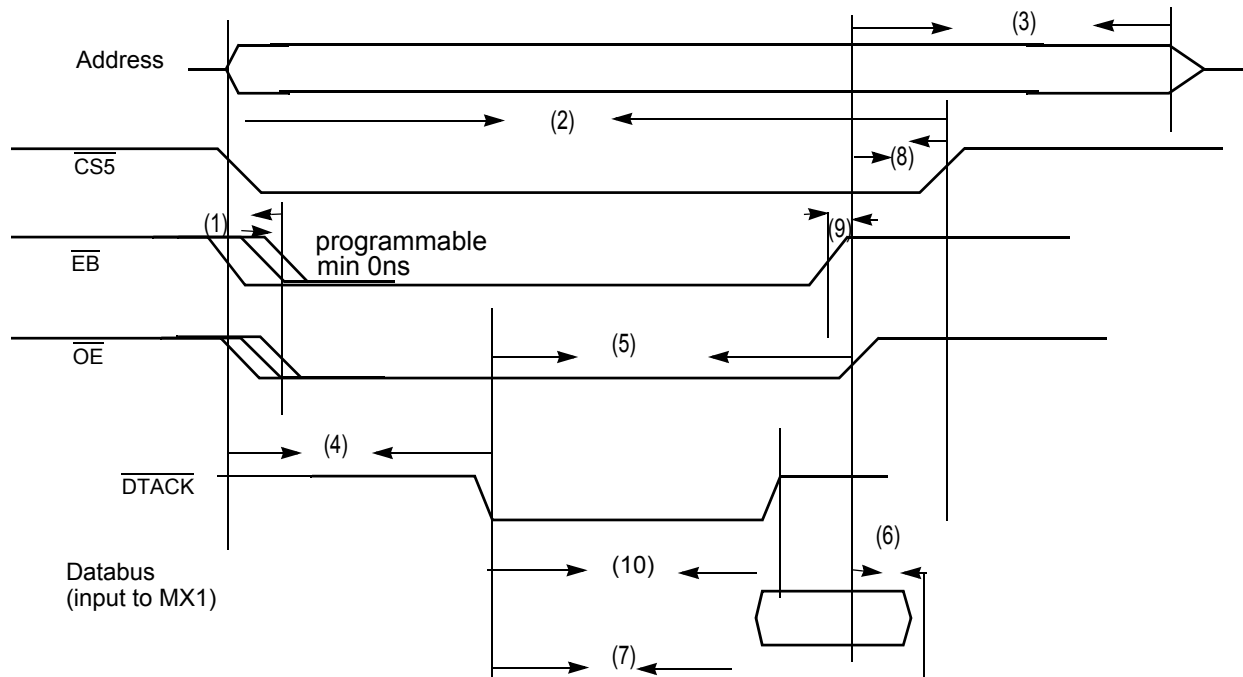

Figure 6. $\overline{\text{DTACK}}$ READ Cycle without DMA

Table 14. Parameters for Read Cycle, WSC = 111111, $\overline{\text{DTACK_SEL}}=0$, HKCL=96MHz

Number	Characteristic	(3.0 ± 0.3) V		Unit
		Minimum	Maximum	
1	$\overline{\text{OE}}$ and $\overline{\text{EB}}$ assertion time	See note 2	–	ns
2	$\overline{\text{CS5}}$ pulse width	3T	–	ns
3	$\overline{\text{OE}}$ negated to address inactive	46.44	–	ns
4	$\overline{\text{DTACK}}$ asserted after $\overline{\text{CS5}}$ asserted	–	1019T	ns
5	$\overline{\text{DTACK}}$ asserted to $\overline{\text{OE}}$ negated	3T+2.2	4T+6.86	ns
6	Data hold timing after $\overline{\text{OE}}$ negated	0	–	ns

Specifications

Table 14. Parameters for Read Cycle, WSC = 111111, DTACK_SEL=0, HKCL=96MHz (Continued)

Number	Characteristic	(3.0 ± 0.3) V		Unit
		Minimum	Maximum	
7	Data ready after \overline{DTACK} asserted	0	T	ns
8	OE negated to CS negated	$0.5T+0.24$	$0.5T+0.67$	ns
9	OE negated after EB negated	0.5	1.5	ns
10	\overline{DTACK} pulse width	1T	3T	ns

Note:

0. \overline{DTACK} assert means \overline{DTACK} become low level.
1. T is the system clock period. (For 96MHz system clock)
2. OE and EB assertion time is programmable by OEA bit in CS5L register. \overline{EB} assertion in read cycle will occur only when EBC bit in CS5L register is clear.
3. Address becomes valid and CS asserts at the start of read access cycle.
4. The external \overline{DTACK} input requirement is eliminated when CS5 is programmed to use internal wait state.

3.8.2.2 DTACK Read Cycle DMA Enabled

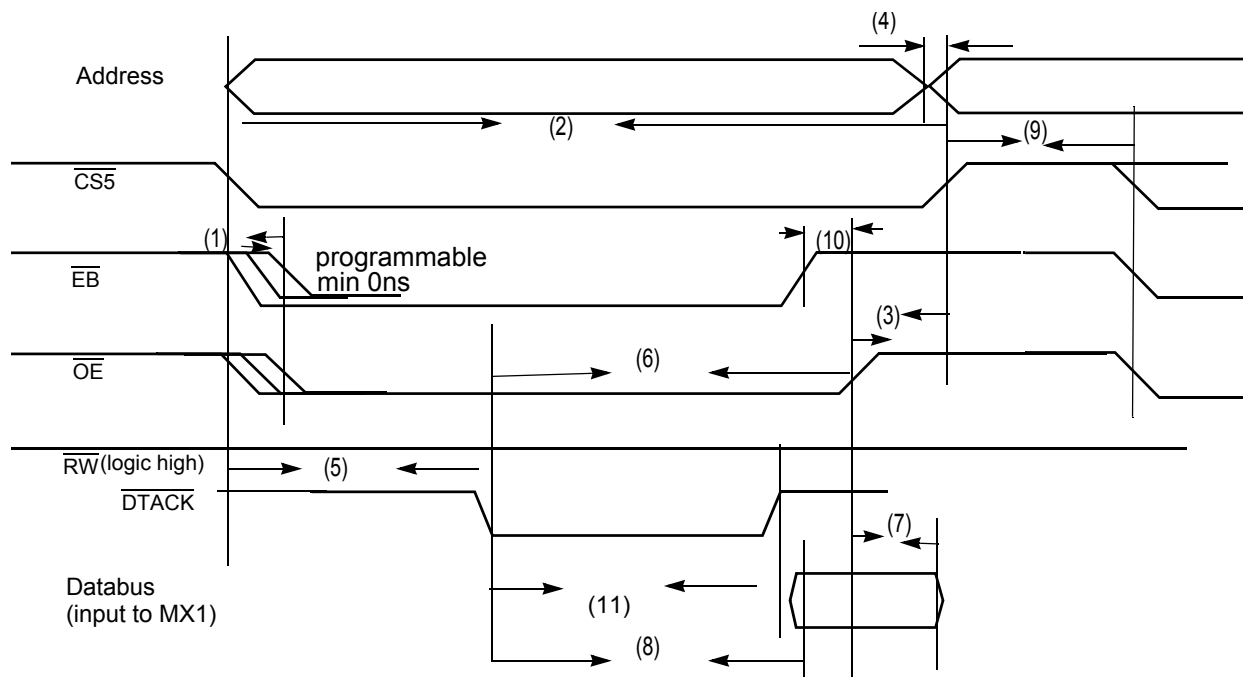

Figure 7. DTACK Read Cycle DMA Enabled

Table 15. Parameters for Read Cycle WSC = 111111, DTACK_SEL=0, HCLK=96MHz

Number	Characteristic	(3.0 ± 0.3) V		Unit
		Minimum	Maximum	
1	\overline{OE} and \overline{EB} assertion time	See note 2	–	ns

Table 15. Parameters for Read Cycle WSC = 111111, DTACK_SEL=0, HCLK=96MHz (Continued)

Number	Characteristic	(3.0 ± 0.3) V		Unit
		Minimum	Maximum	
2	\overline{CS} pulse width	3T	–	ns
3	\overline{OE} negated before $\overline{CS5}$ is negated	0.5T+0.24	0.5T+0.67	ns
4	Address inactive before \overline{CS} negated	–	0.93	ns
5	\overline{DTACK} asserted after $\overline{CS5}$ asserted	–	1019T	ns
6	\overline{DTACK} asserted to \overline{OE} negated	3T+2.2	4T+6.86	ns
7	Data hold timing after \overline{OE} negated	0	–	ns
8	Data ready after DTACK is asserted	–	T	ns
9	\overline{CS} deactive to next \overline{CS} active	T	–	ns
10	OE negate after EB negate	0.5	1.5	ns
11	\overline{DTACK} pulse width	1T	3T	ns

Note:

0. \overline{DTACK} assert mean \overline{DTACK} become low.
1. T is the system clock period. (For 96MHz system clock)
2. \overline{OE} and EB assertion time is programmable by OEA bit in CS5L register. \overline{EB} assertion in read cycle will occur only when EBC bit in CS5L register is clear.
3. Address becomes valid and \overline{CS} asserts at the start of read access cycle.
4. The external \overline{DTACK} input requirement is eliminated when $\overline{CS5}$ is programmed to use internal wait state.

Specifications

3.8.2.3 DTACK Write Cycle without DMA

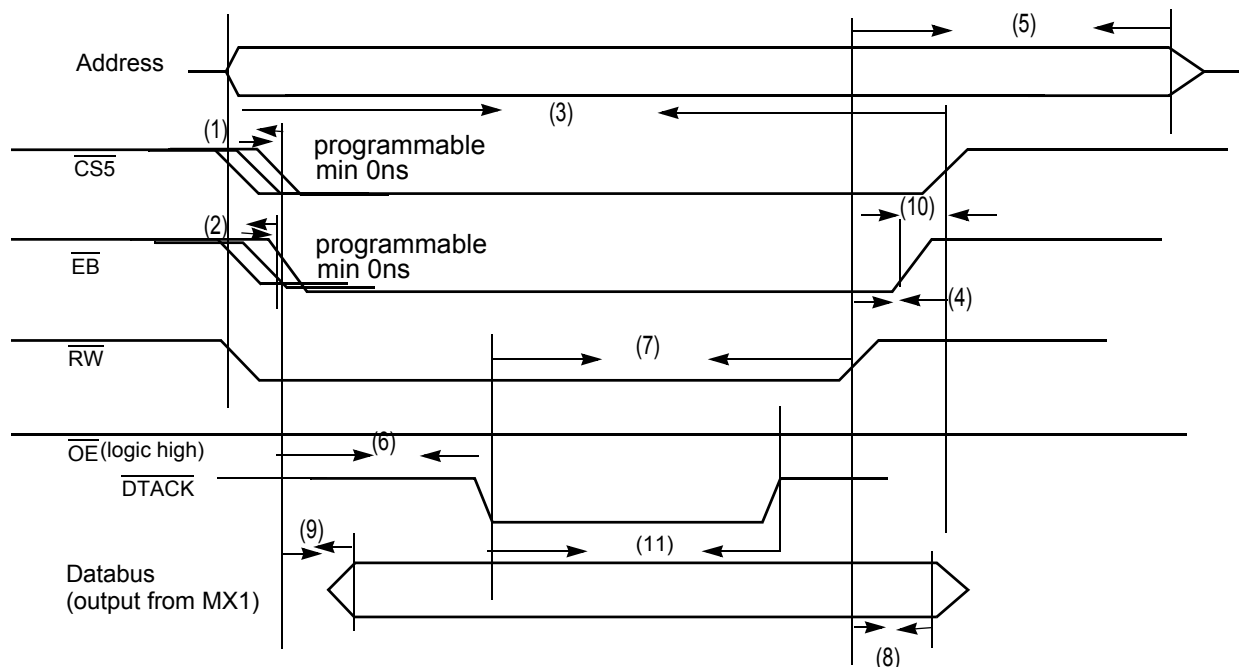

Figure 8. DTACK Write Cycle without DMA

Table 16. Parameters for Write Cycle WSC = 111111, DTACK_SEL=0, HKCL=96MHz

Number	Characteristic	(3.0 ± 0.3) V		Unit
		Minimum	Maximum	
1	$\overline{CS5}$ assertion time	See note 2.	–	ns
2	\overline{EB} assertion time	See note 2	–	ns
3	$\overline{CS5}$ pulse width	3T	–	ns
4	\overline{RW} negated before $\overline{CS5}$ is negated	1.5T+0.58	1.5T+1.58	ns
5	\overline{RW} negated to Address inactive	57.31	–	ns
6	\overline{DTACK} asserted after $\overline{CS5}$ asserted	–	1019T	ns
7	\overline{DTACK} asserted to \overline{RW} negated	2T+1.8	3T+5.26	ns
8	Data hold timing after \overline{RW} negated	1.5T-0.59	–	ns
9	Data ready after $\overline{CS5}$ is asserted	–	T	ns
10	\overline{EB} negated before $\overline{CS5}$ is negated	0.5T+0.74	0.5T+2.17	ns
11	\overline{DTACK} pulse width	1T	3T	ns

Note:

0. \overline{DTACK} assert mean \overline{DTACK} become low.
1. T is the system clock period. (For 96MHz system clock)
2. $\overline{CS5}$ assertion can be controlled by CSA bits. \overline{EB} assertion can also be programmed by WEA bits in the CS5L register.
3. Address becomes valid and \overline{RW} asserts at the start of write access cycle.
4. The external \overline{DTACK} input requirement is eliminated when $\overline{CS5}$ is programmed to use internal wait state.

3.8.2.4 DTACK Write Cycle DMA Enabled

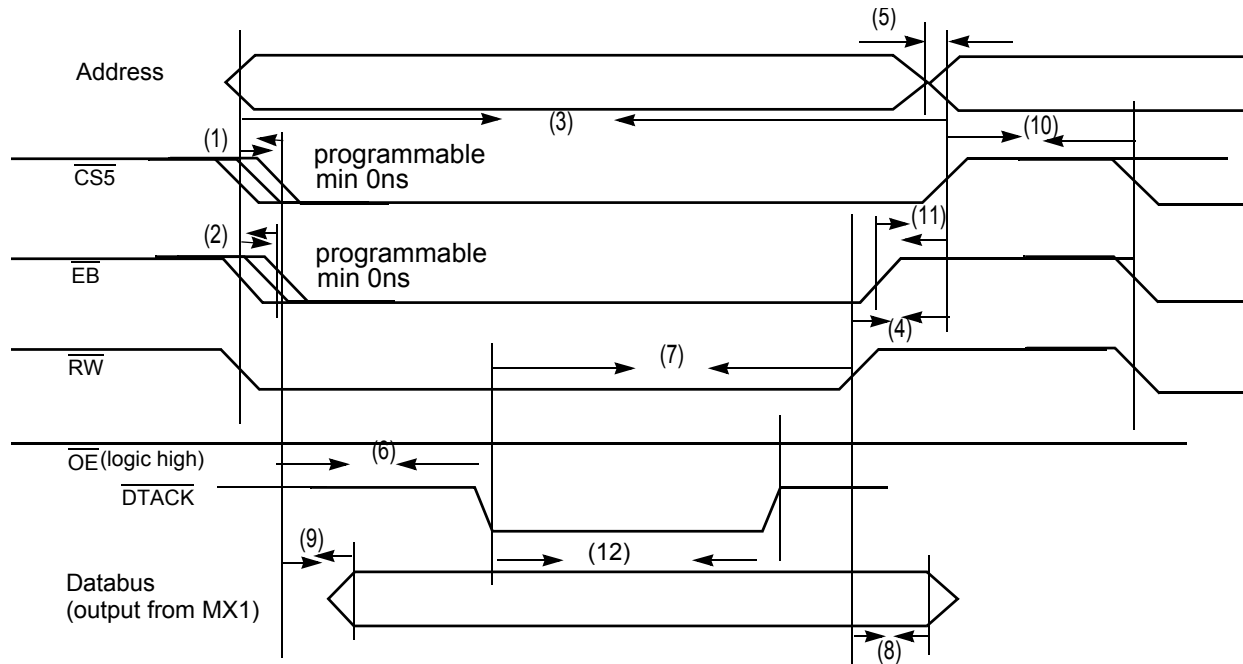

Figure 9. DTACK Write Cycle DMA Enabled

Table 17. WSC = Parameters for Write Cycle 111111, DTACK_SEL=0, HCLK=96MHz

Number	Characteristic	(3.0 ± 0.3) V		Unit
		Minimum	Maximum	
1	$\overline{CS5}$ assertion time	See note 2	–	ns
2	\overline{EB} assertion time	See note 2	–	ns
3	$\overline{CS5}$ pulse width	3T	–	ns
4	\overline{RW} negated before $\overline{CS5}$ is negated	1.5T+0.58	1.5T+1.58	ns
5	Address inactive before $\overline{CS5}$ negated	–	0.93	ns
6	\overline{DTACK} asserted after $\overline{CS5}$ asserted	–	1019T	ns
7	\overline{DTACK} asserted to \overline{RW} negated	2T+1.8	3T+5.26	ns
8	Data hold timing after \overline{RW} negated	1.5T-0.59	–	ns
9	Data ready after $\overline{CS5}$ is asserted	–	T	ns
10	$\overline{CS5}$ deactive to next $\overline{CS5}$ active	T	–	ns
11	\overline{EB} negate to $\overline{CS5}$ negate	0.5T+0.74	0.5T+2.17	ns
12	\overline{DTACK} pulse width	1T	3T	ns

Note:

0. \overline{DTACK} assert mean \overline{DTACK} become low.
1. T is the system clock period. (For 96MHz system clock)
2. $\overline{CS5}$ assertion can be controlled by CSA bits. \overline{EB} assertion also can be programmed by WEA bits in the CS5L register.
3. Address becomes valid and \overline{RW} asserts at the start of write access cycle.
4. The external DTACK input requirement is eliminated when CS5 is programmed to use internal wait state.

Specifications

3.8.3 EIM External Bus Timing

The following timing diagrams show the timing of accesses to memory or a peripheral.

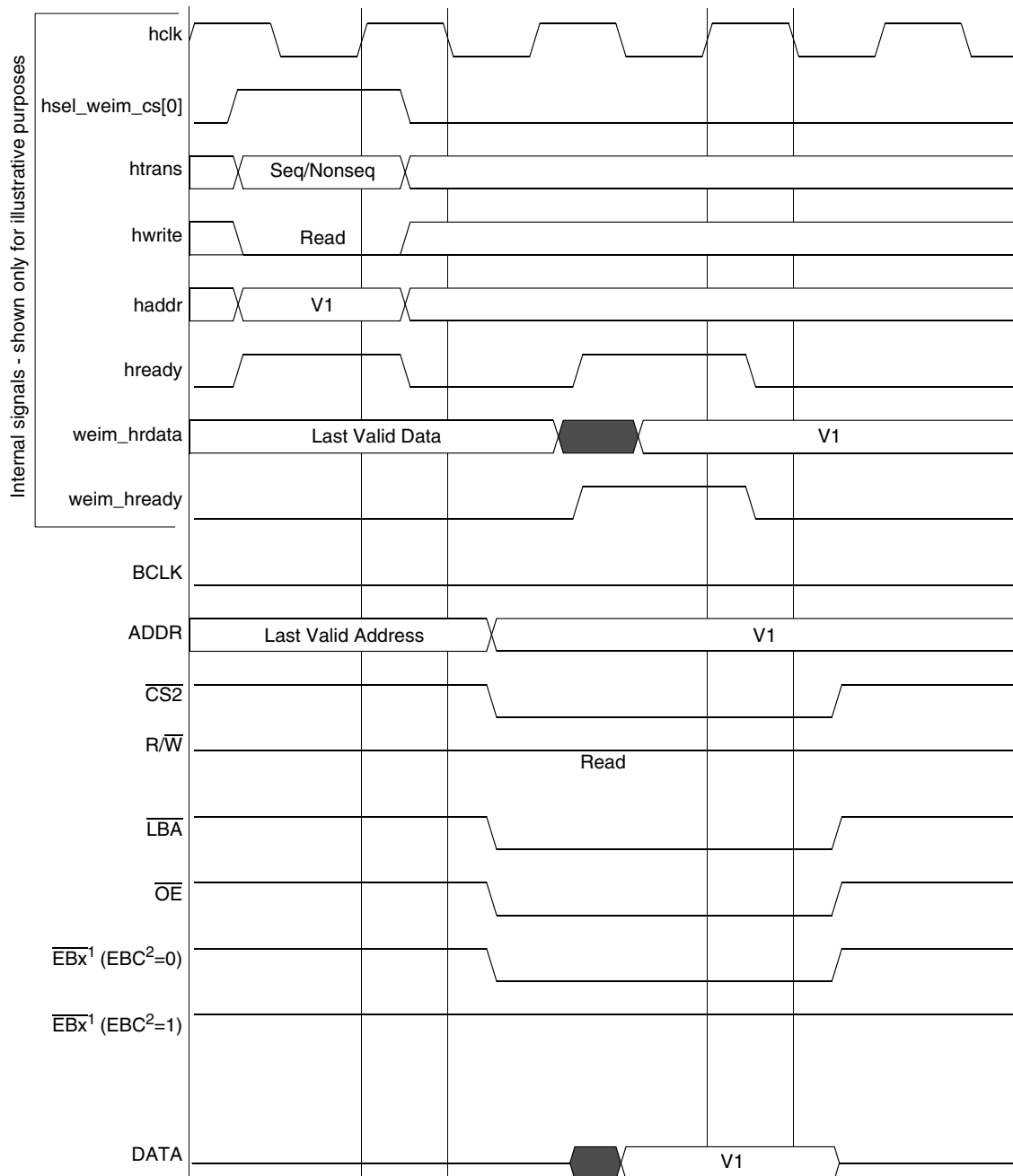

Note 1: x = 0, 1, 2 or 3

Note 2: EBC = Enable Byte Control bit (bit 11) on the Chip Select Control Register

Figure 10. WSC = 1, A.HALF/E.HALF

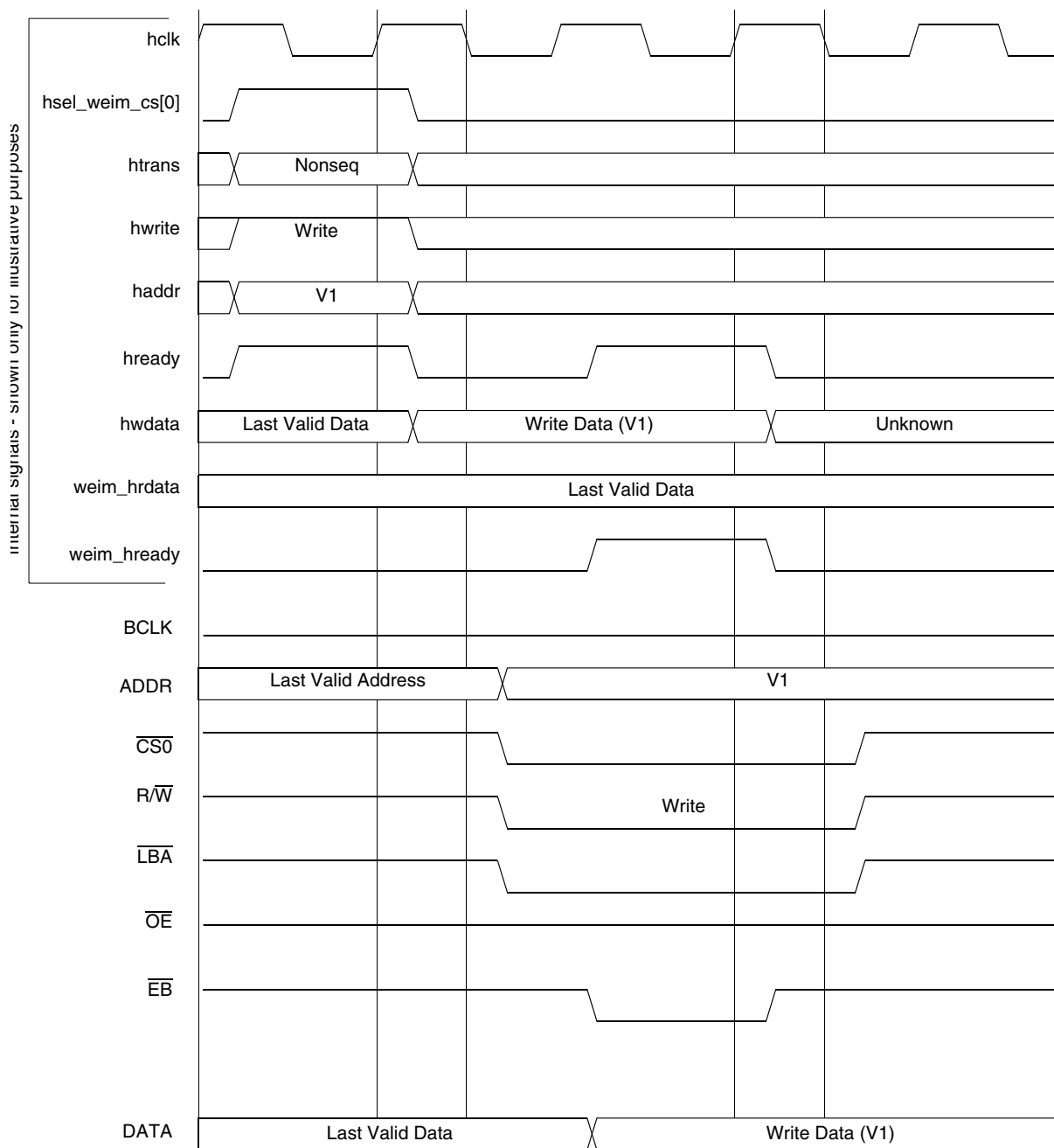
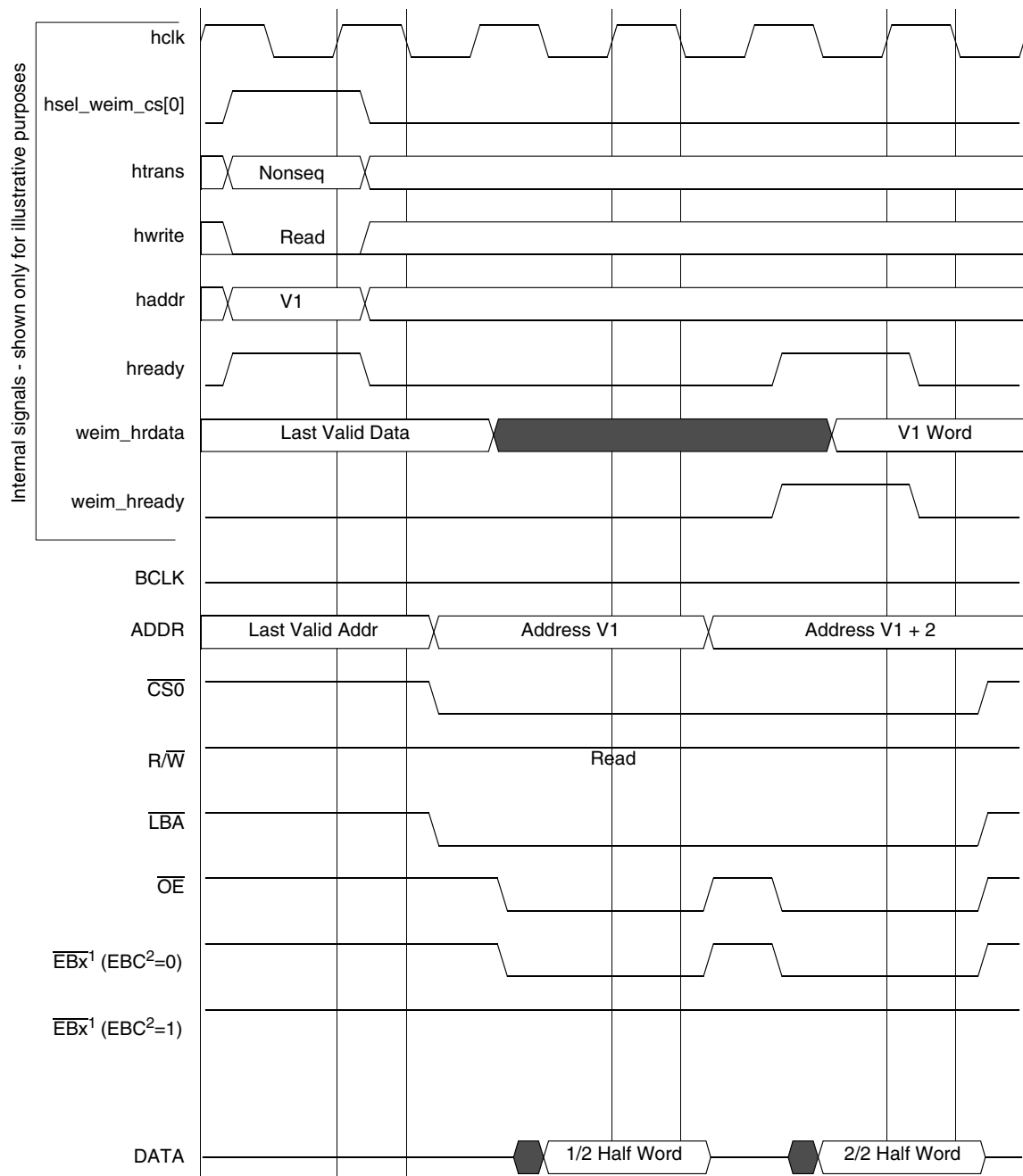

Figure 11. WSC = 1, WEA = 1, WEN = 1, A.HALF/E.HALF

Specifications



Note 1: x = 0, 1, 2 or 3

Note 2: EBC = Enable Byte Control bit (bit 11) on the Chip Select Control Register

Figure 12. WSC = 1, OEA = 1, A.WORD/E.HALF

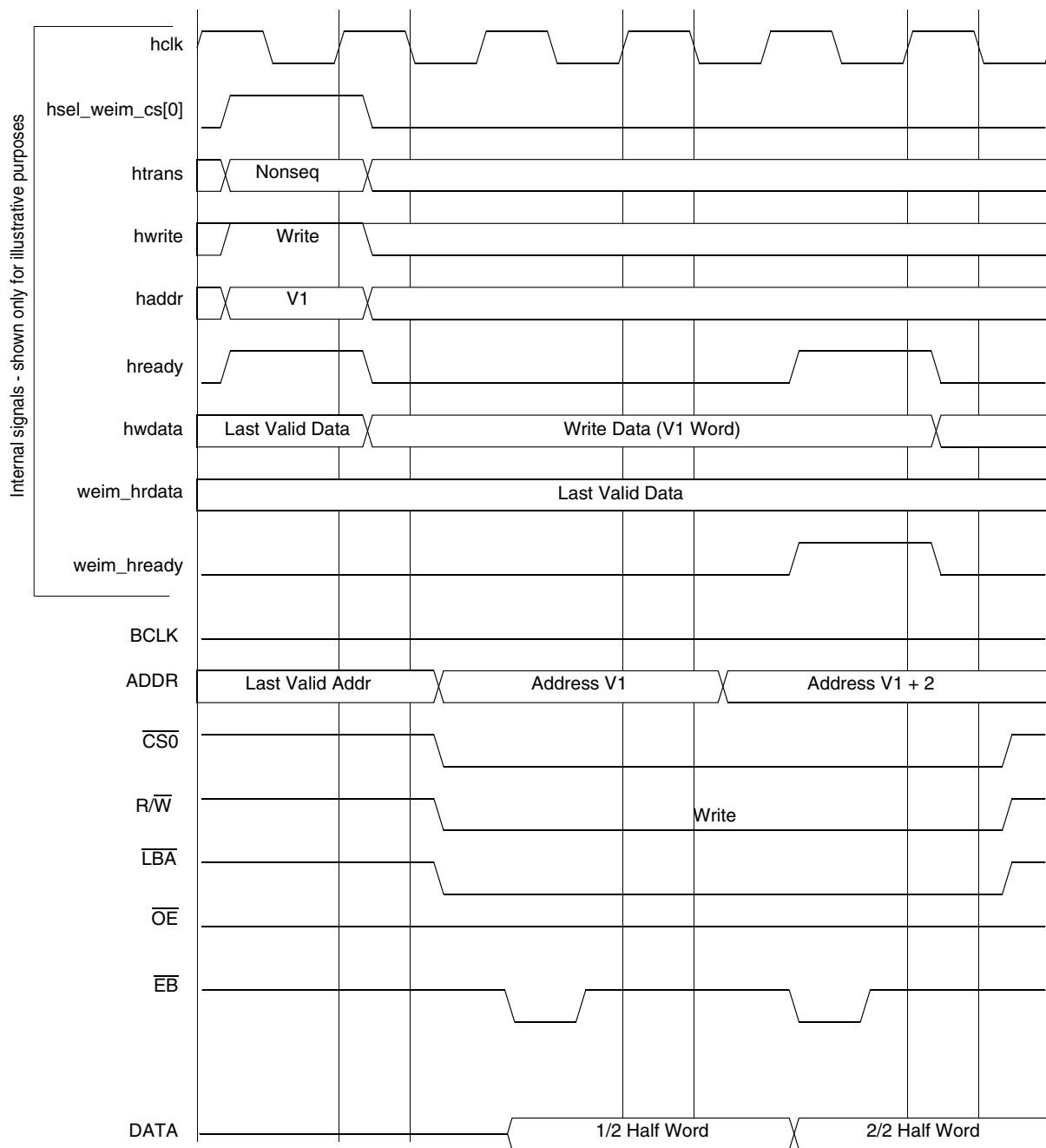

Figure 13. WSC = 1, WEA = 1, WEN = 2, A.WORD/E.HALF

Specifications

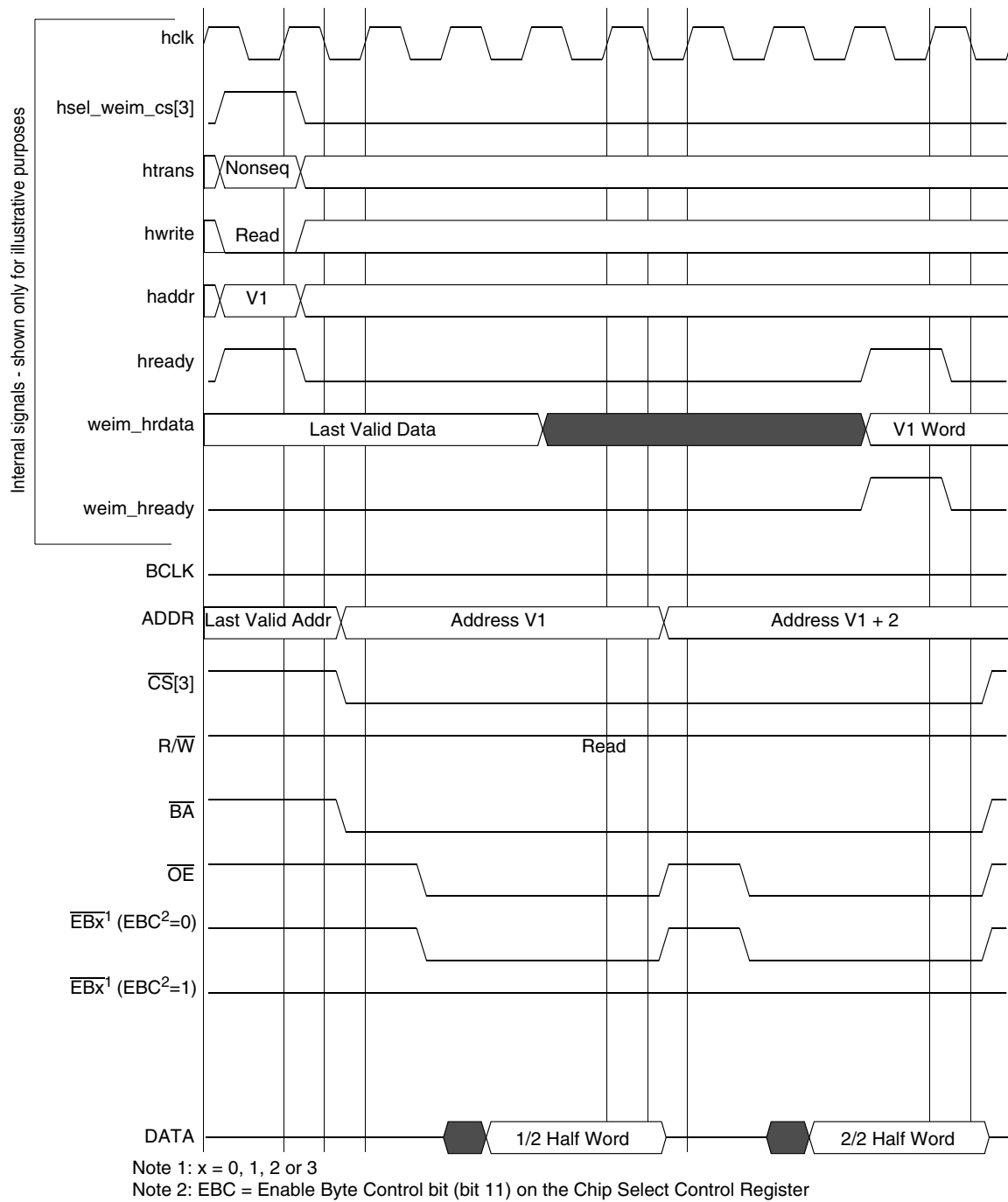

Figure 14. WSC = 3, OEA = 2, A.WORD/E.HALF

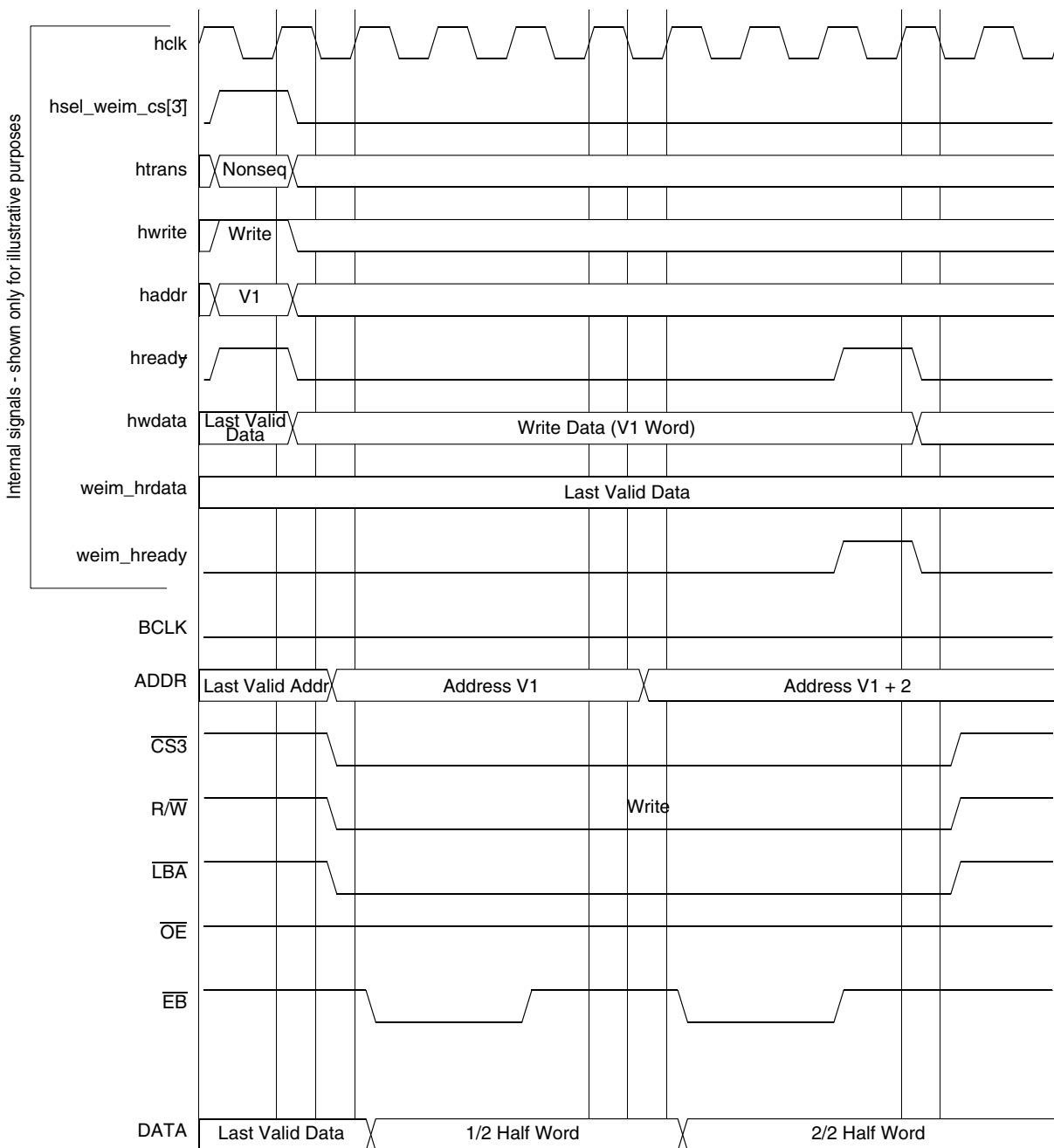

Figure 15. WSC = 3, WEA = 1, WEN = 3, A.WORD/E.HALF

Specifications

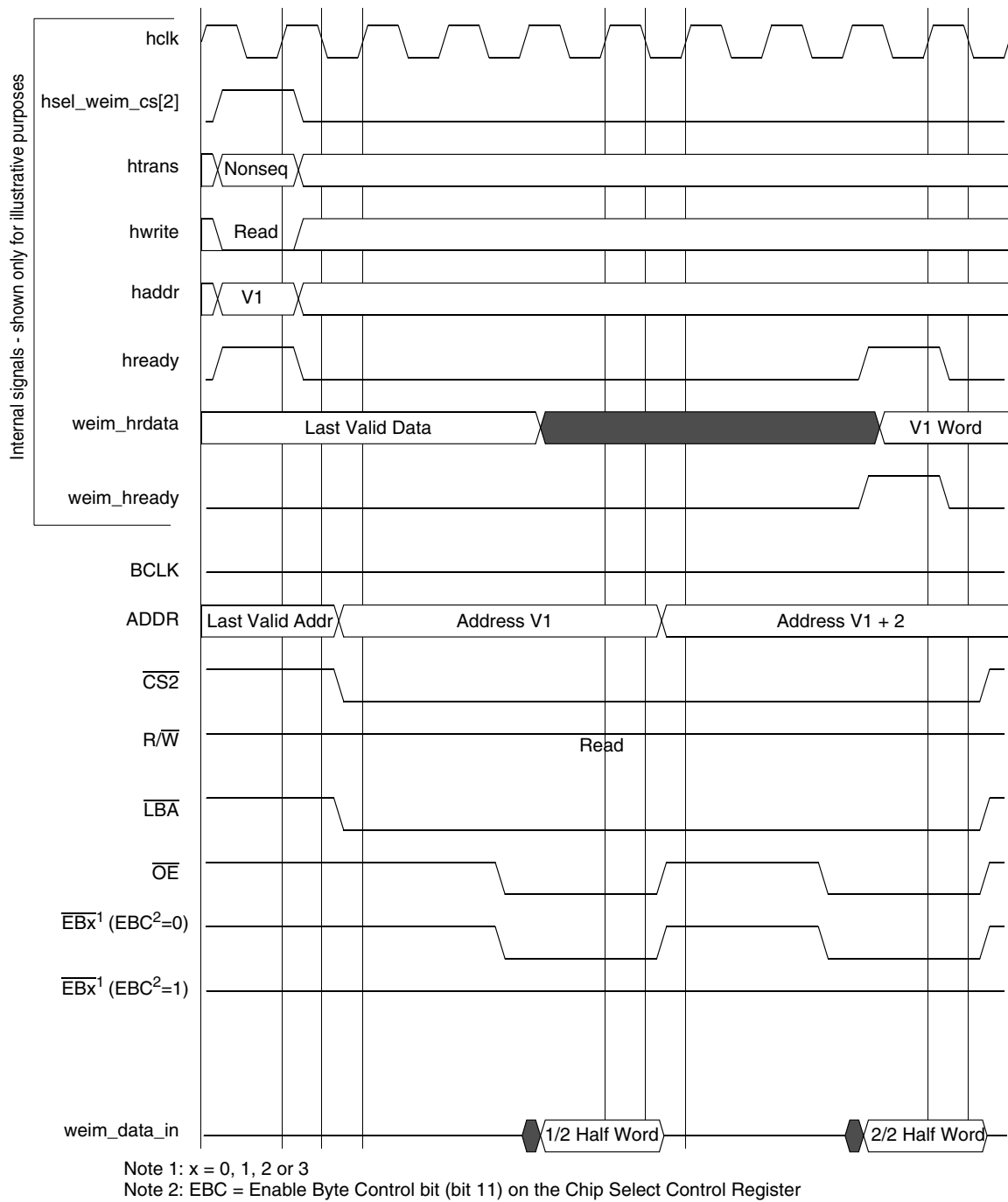

Figure 16. WSC = 3, OEA = 4, A.WORD/E.HALF

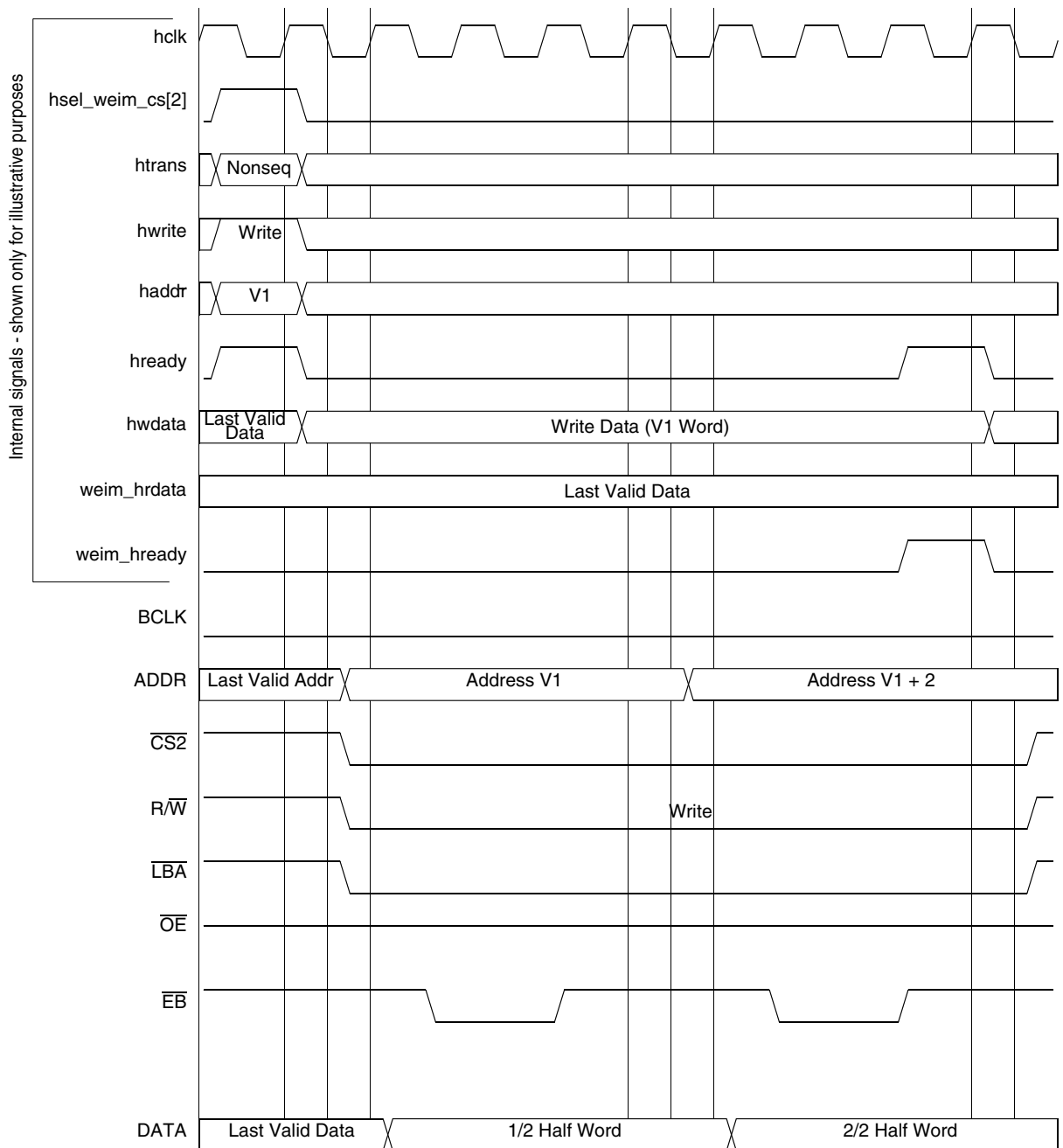

Figure 17. WSC = 3, WEA = 2, WEN = 3, A.WORD/E.HALF

Specifications

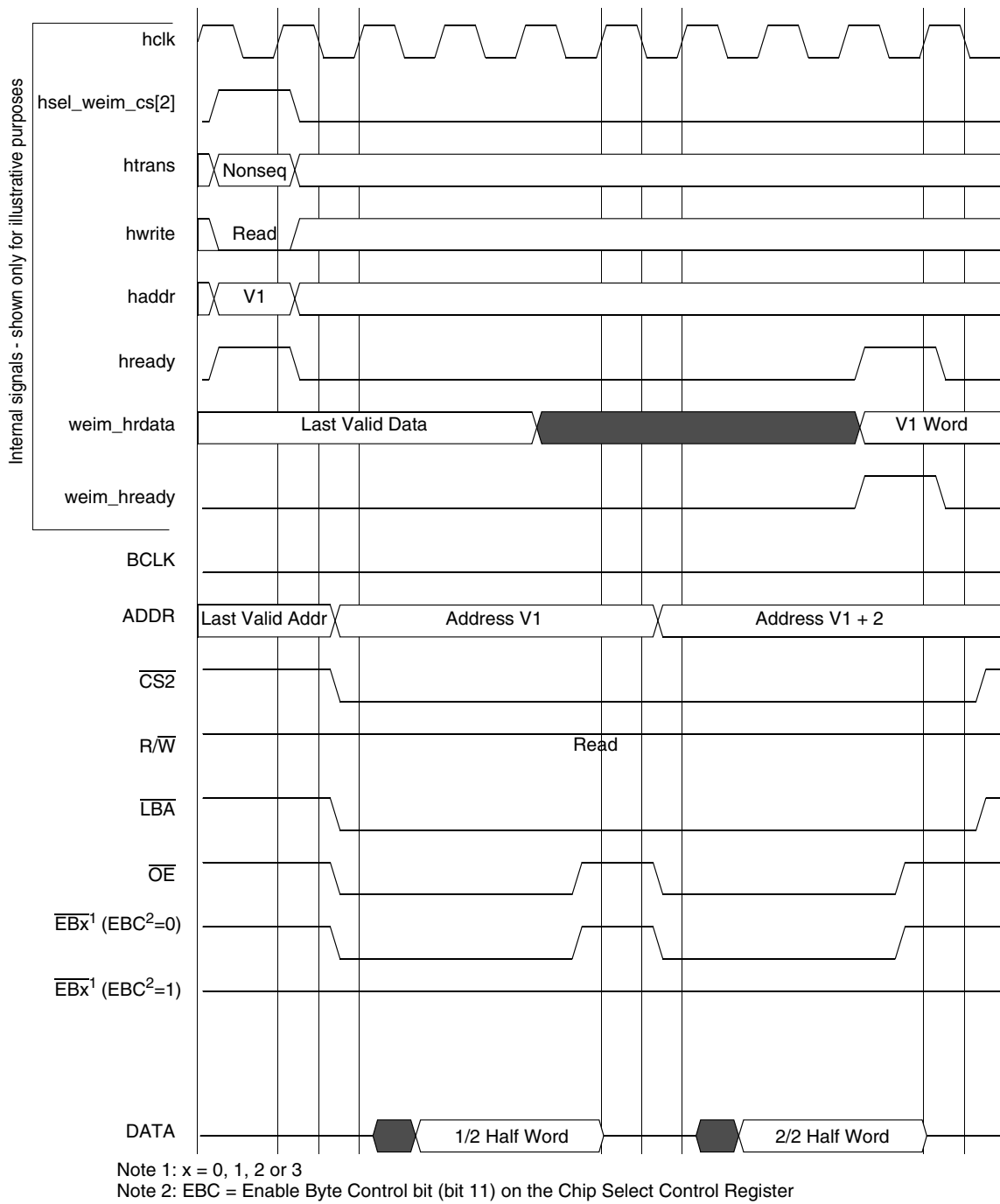

Figure 18. WSC = 3, OEN = 2, A.WORD/E.HALF

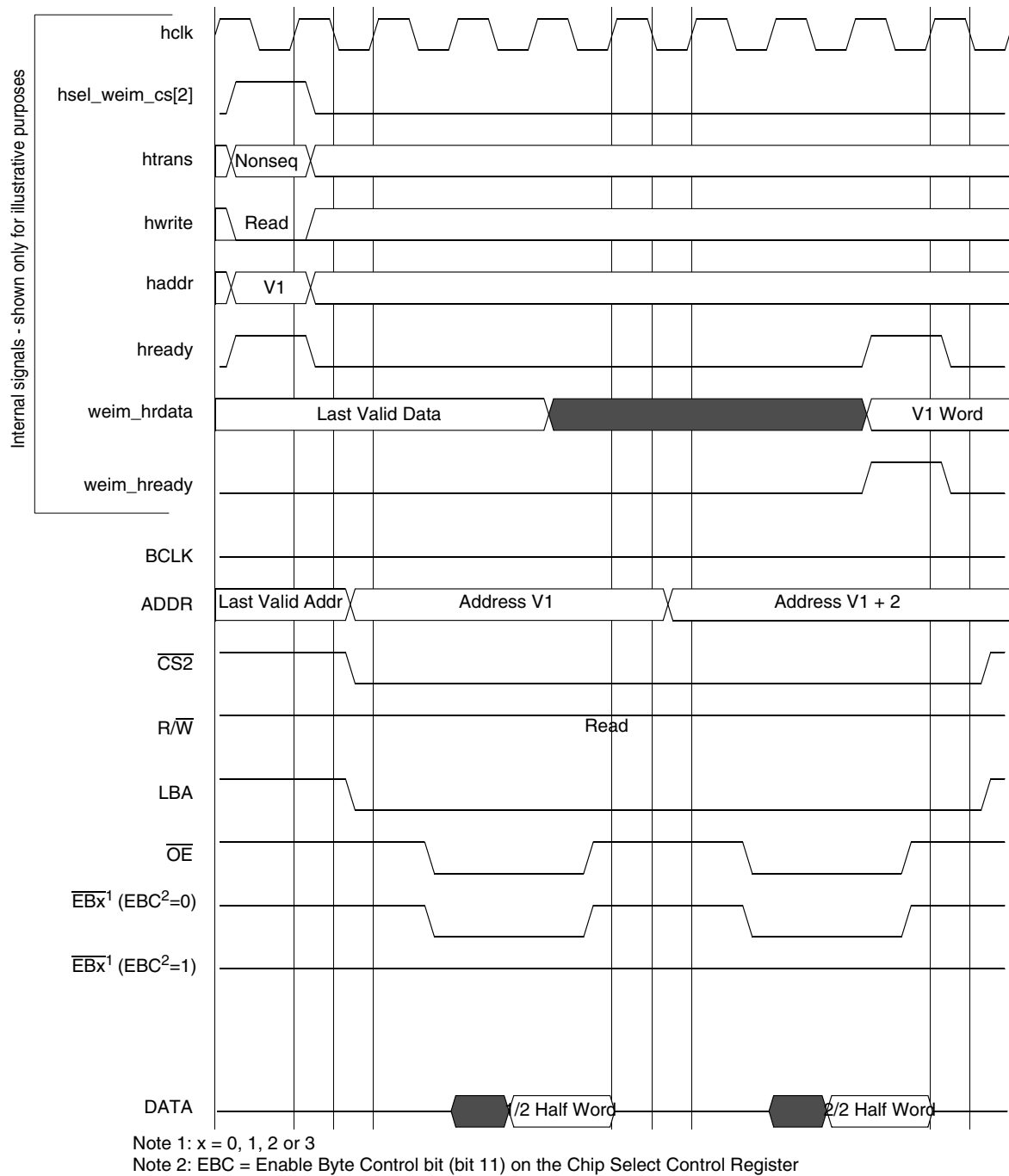

Figure 19. WSC = 3, OEA = 2, OEN = 2, A.WORD/E.HALF

Specifications

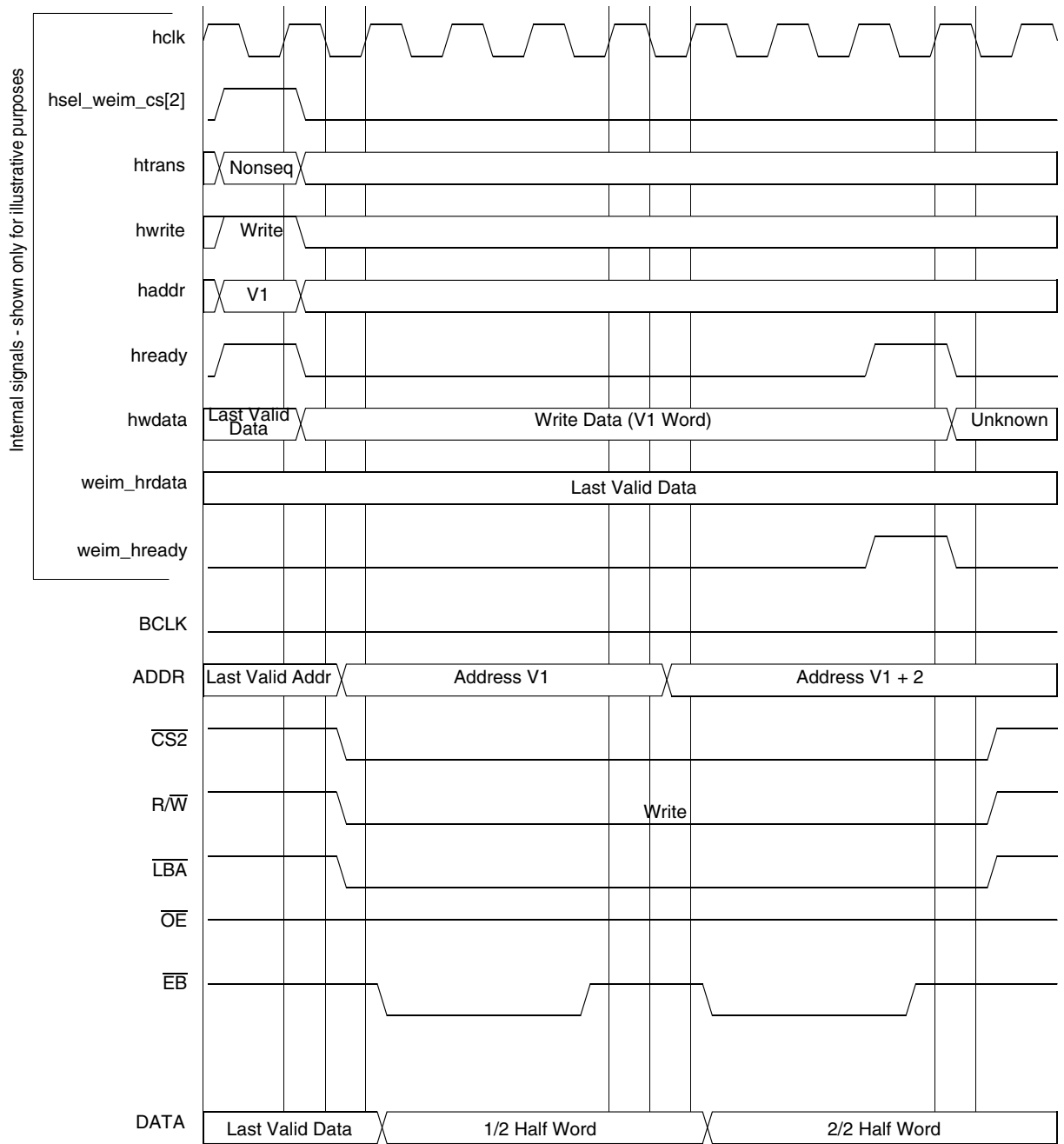

Figure 20. WSC = 2, WWS = 1, WEA = 1, WEN = 2, A.WORD/E.HALF

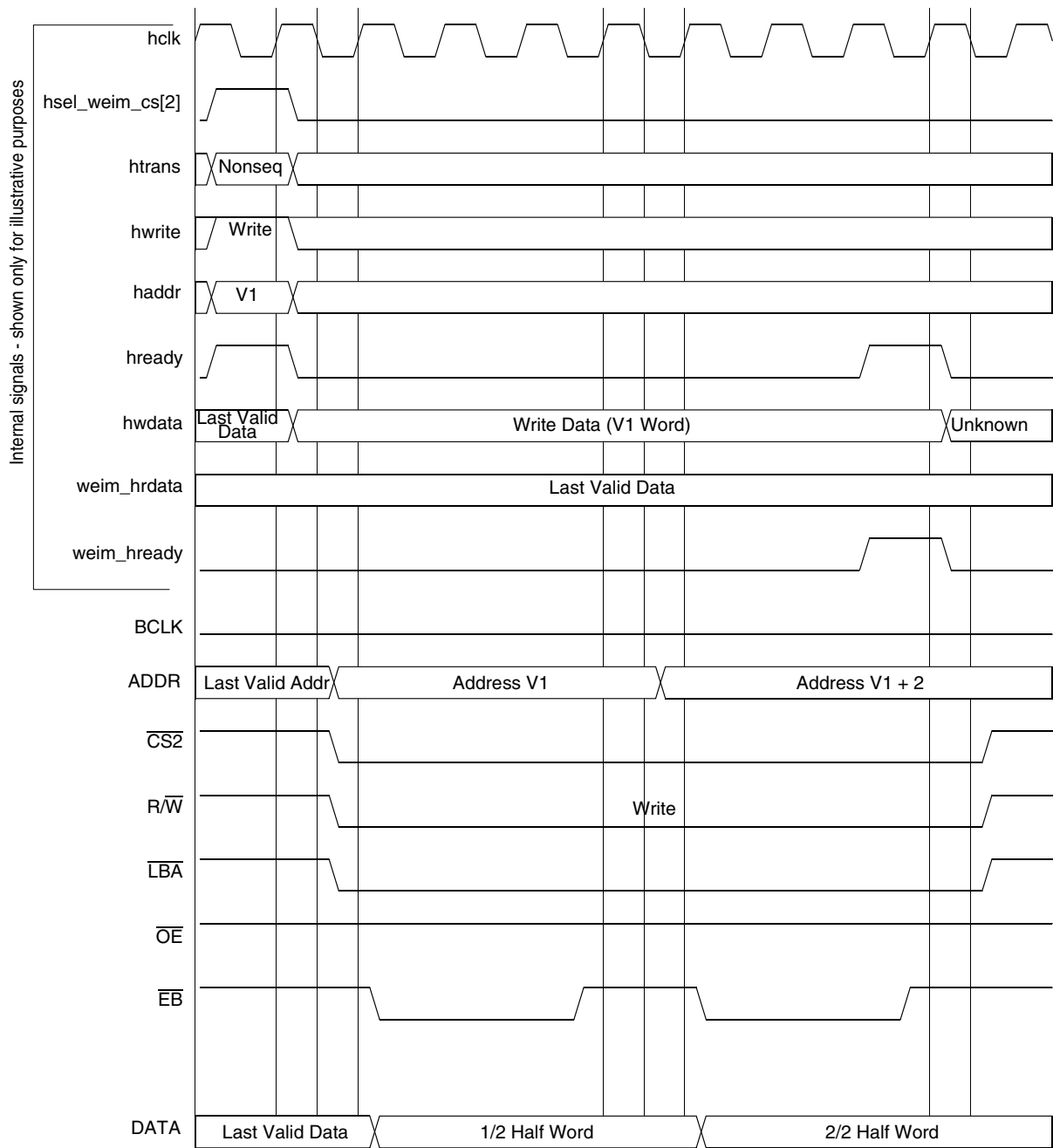
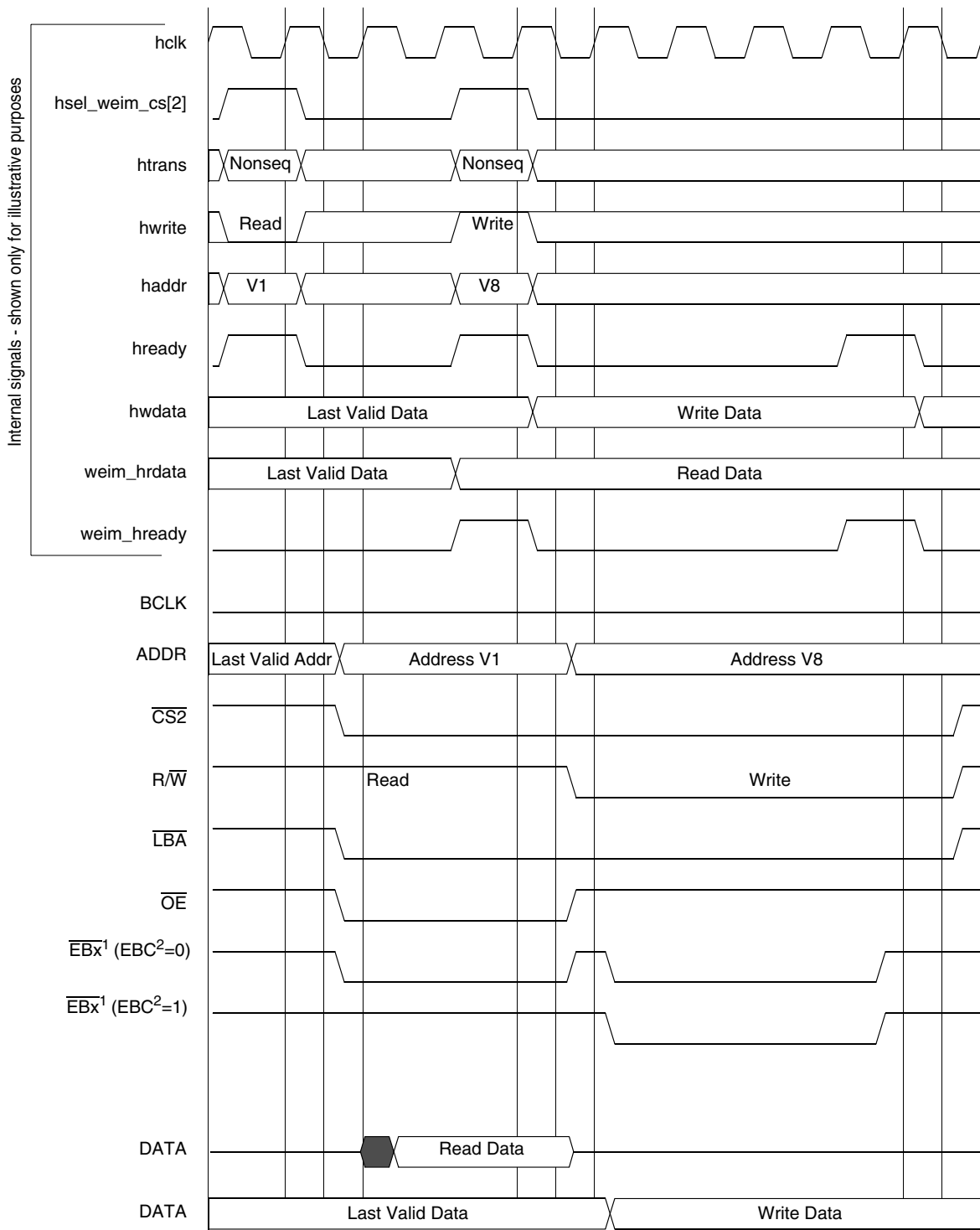

Figure 21. WSC = 1, WWS = 2, WEA = 1, WEN = 2, A.WORD/E.HALF

Specifications



Note 1: x = 0, 1, 2 or 3

Note 2: EBC = Enable Byte Control bit (bit 11) on the Chip Select Control Register

Figure 22. WSC = 2, WWS = 2, WEA = 1, WEN = 2, A.HALF/E.HALF

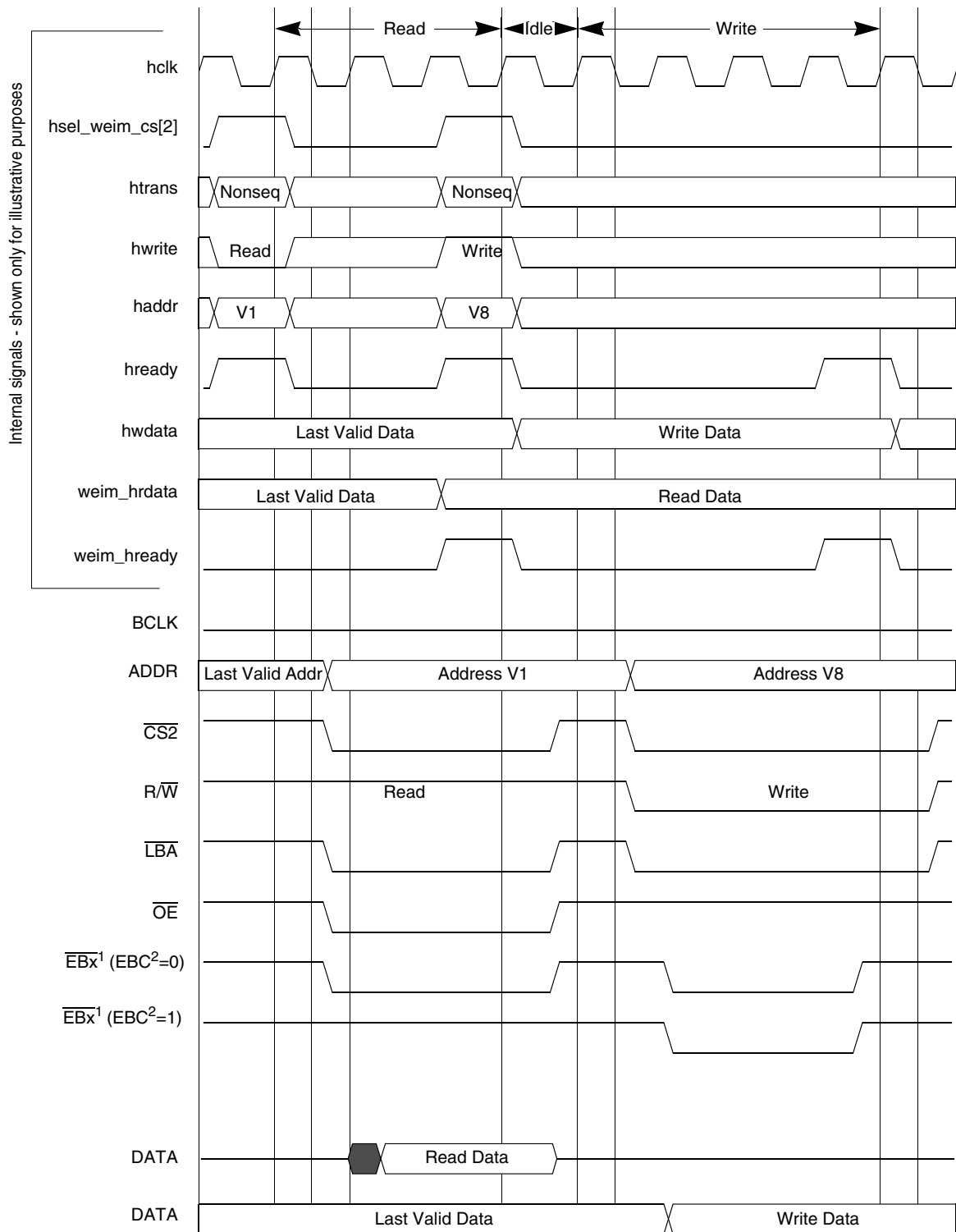

Note 1: x = 0, 1, 2 or 3
 Note 2: EBC = Enable Byte Control bit (bit 11) on the Chip Select Control Register

Figure 23. WSC = 2, WWS = 1, WEA = 1, WEN = 2, EDC = 1, A.HALF/E.HALF

Specifications

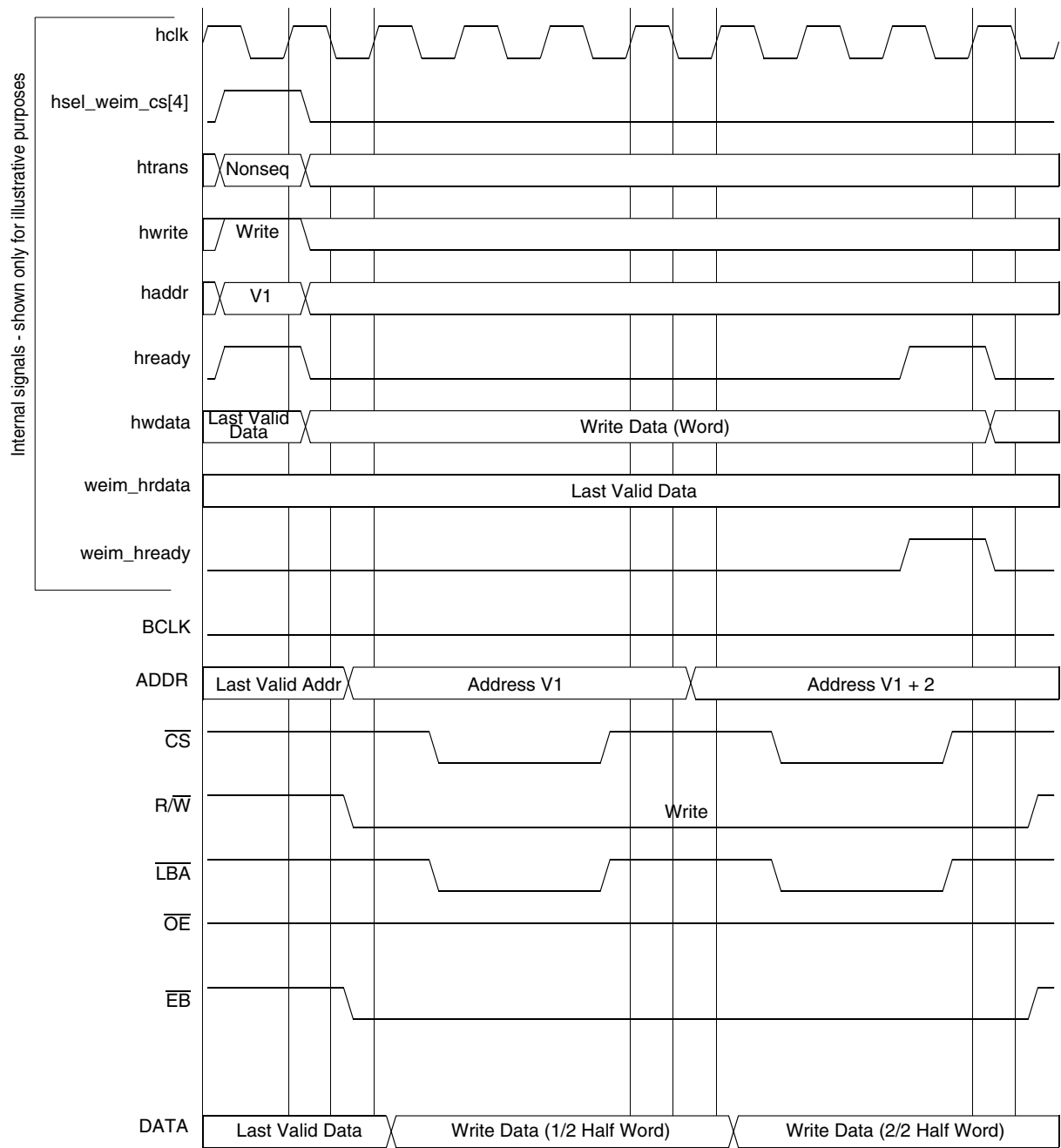
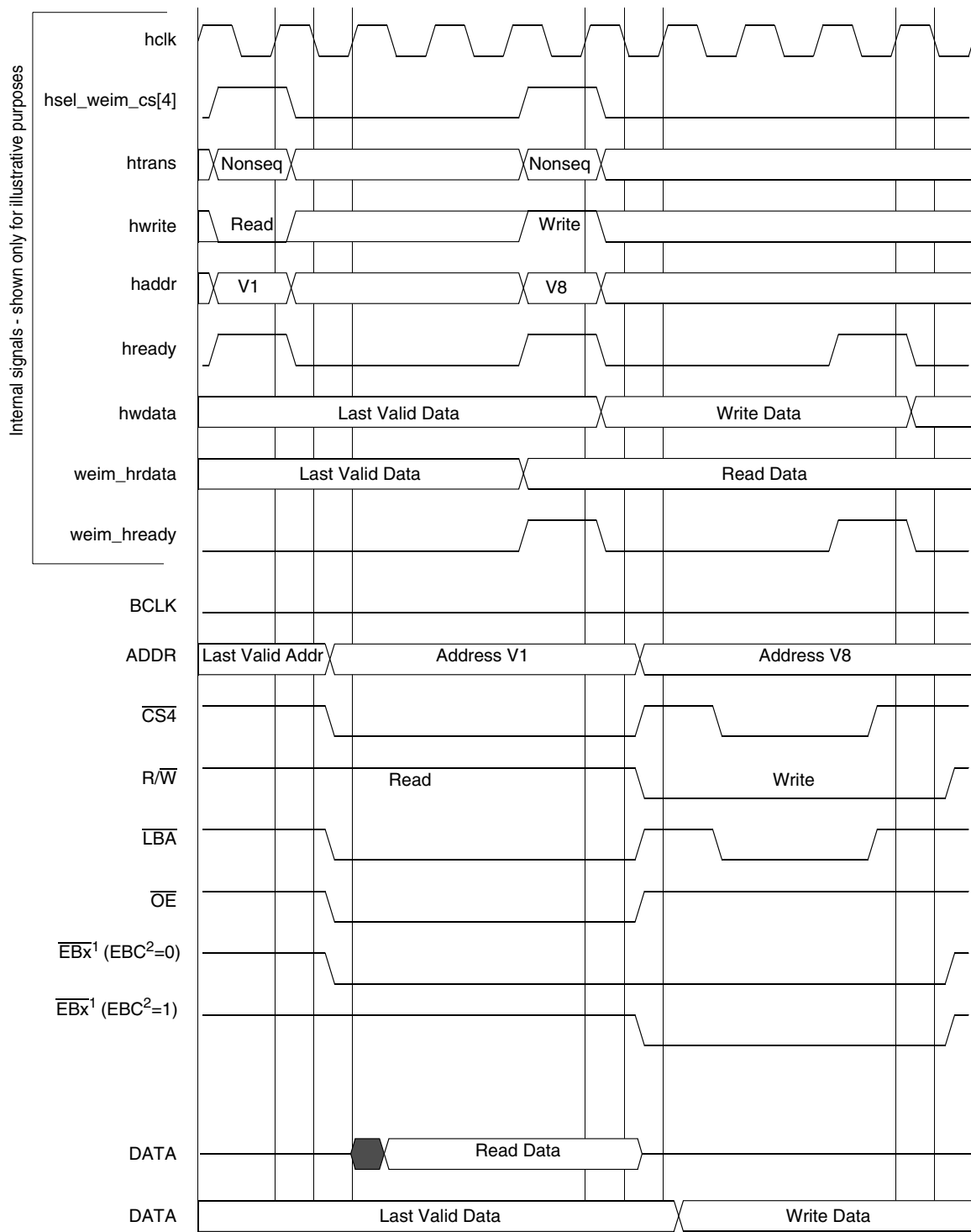

Figure 24. WSC = 2, CSA = 1, WWS = 1, A.WORD/E.HALF



Note 1: x = 0, 1, 2 or 3
 Note 2: EBC = Enable Byte Control bit (bit 11) on the Chip Select Control Register

Figure 25. WSC = 3, CSA = 1, A.HALF/E.HALF

Specifications

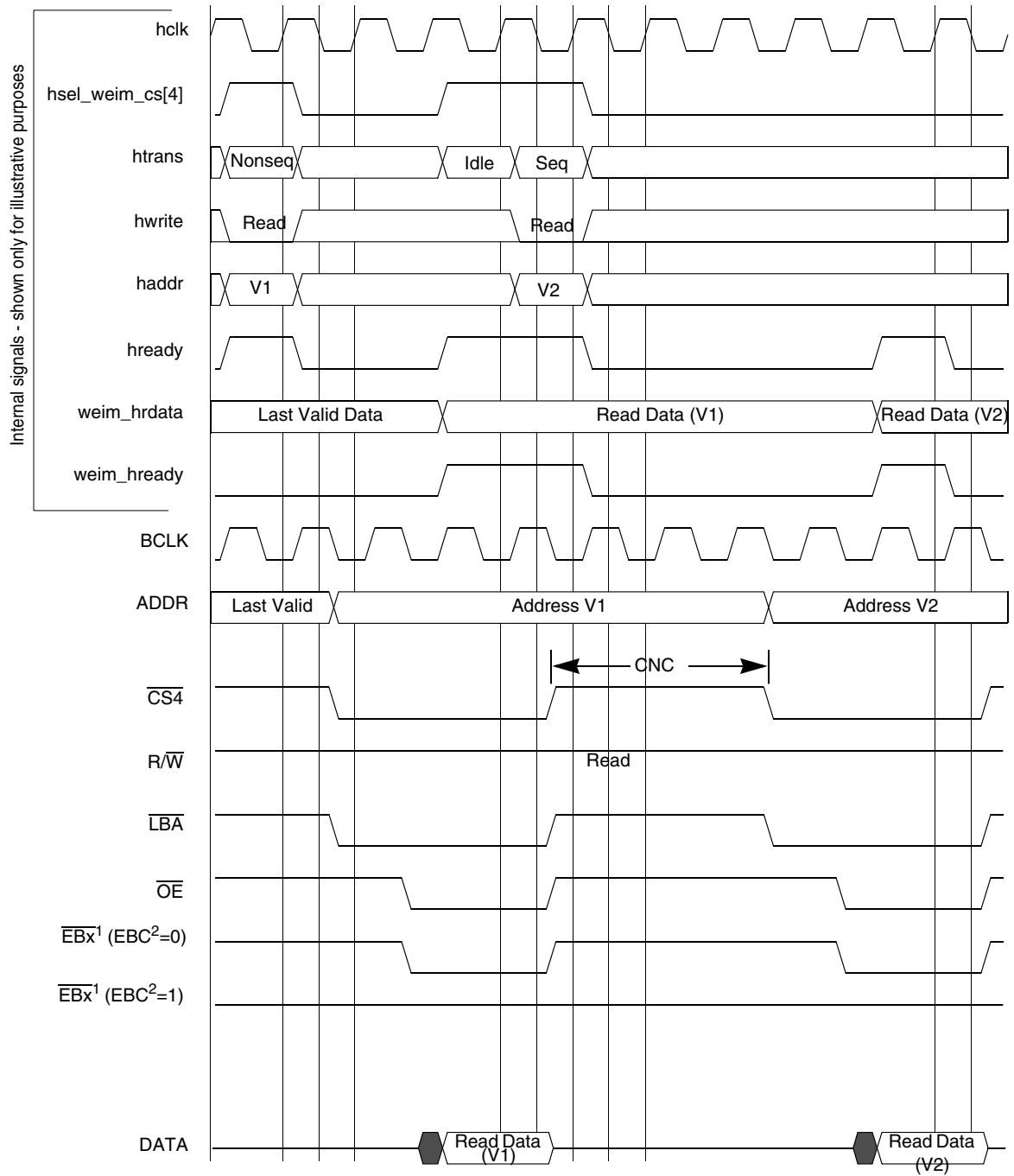

Note 1: x = 0, 1, 2 or 3

Note 2: EBC = Enable Byte Control bit (bit 11) on the Chip Select Control Register

Figure 26. WSC = 2, OEA = 2, CNC = 3, BCM = 1, A.HALF/E.HALF

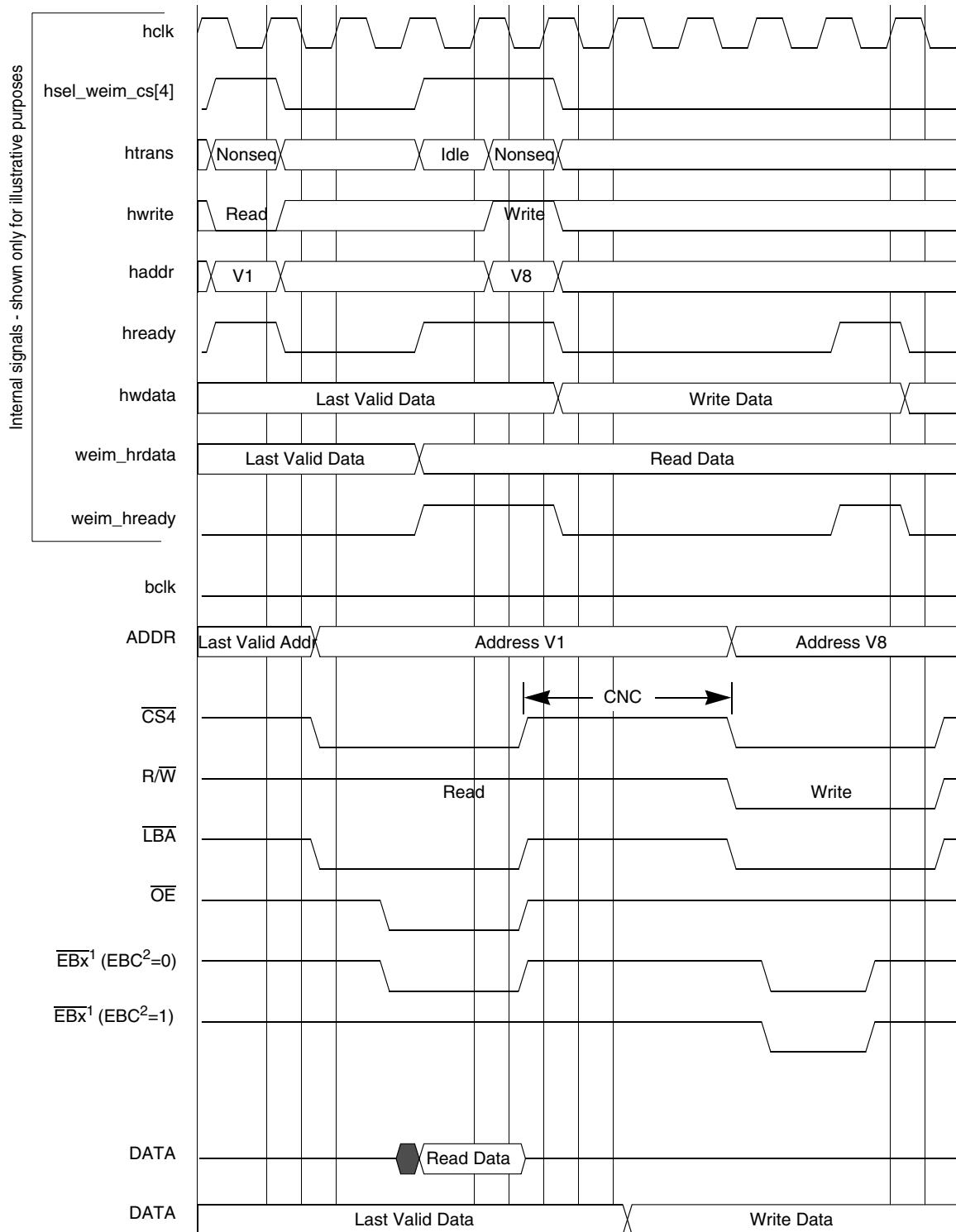

Note 1: x = 0, 1, 2 or 3

Note 2: EBC = Enable Byte Control bit (bit 11) on the Chip Select Control Register

Figure 27. WSC = 2, OEA = 2, WEA = 1, WEN = 2, CNC = 3, A.HALF/E.HALF

Specifications

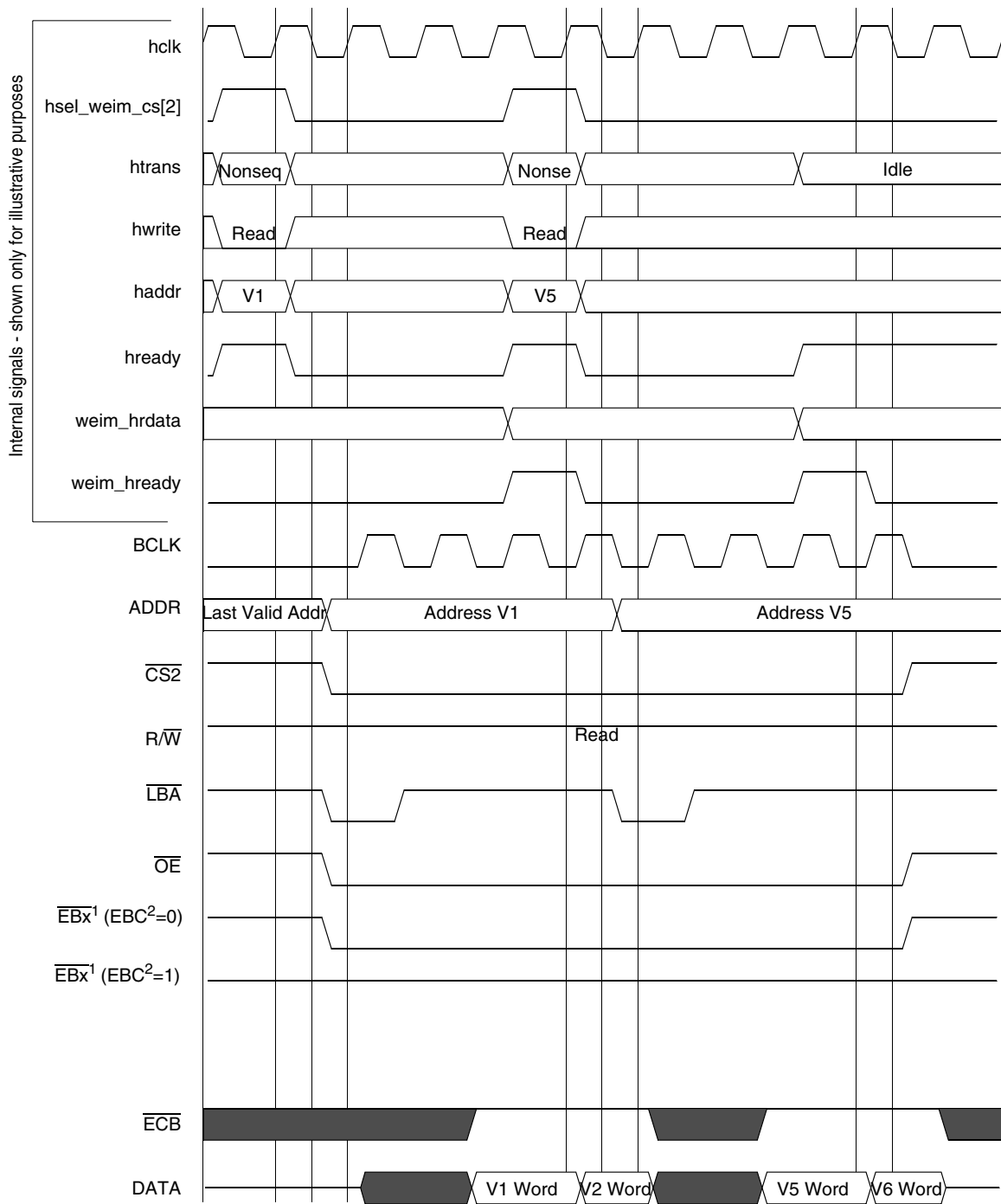

Note 1: x = 0, 1, 2 or 3

Note 2: EBC = Enable Byte Control bit (bit 11) on the Chip Select Control Register

Figure 28. WSC = 3, SYNC = 1, A.HALF/E.HALF

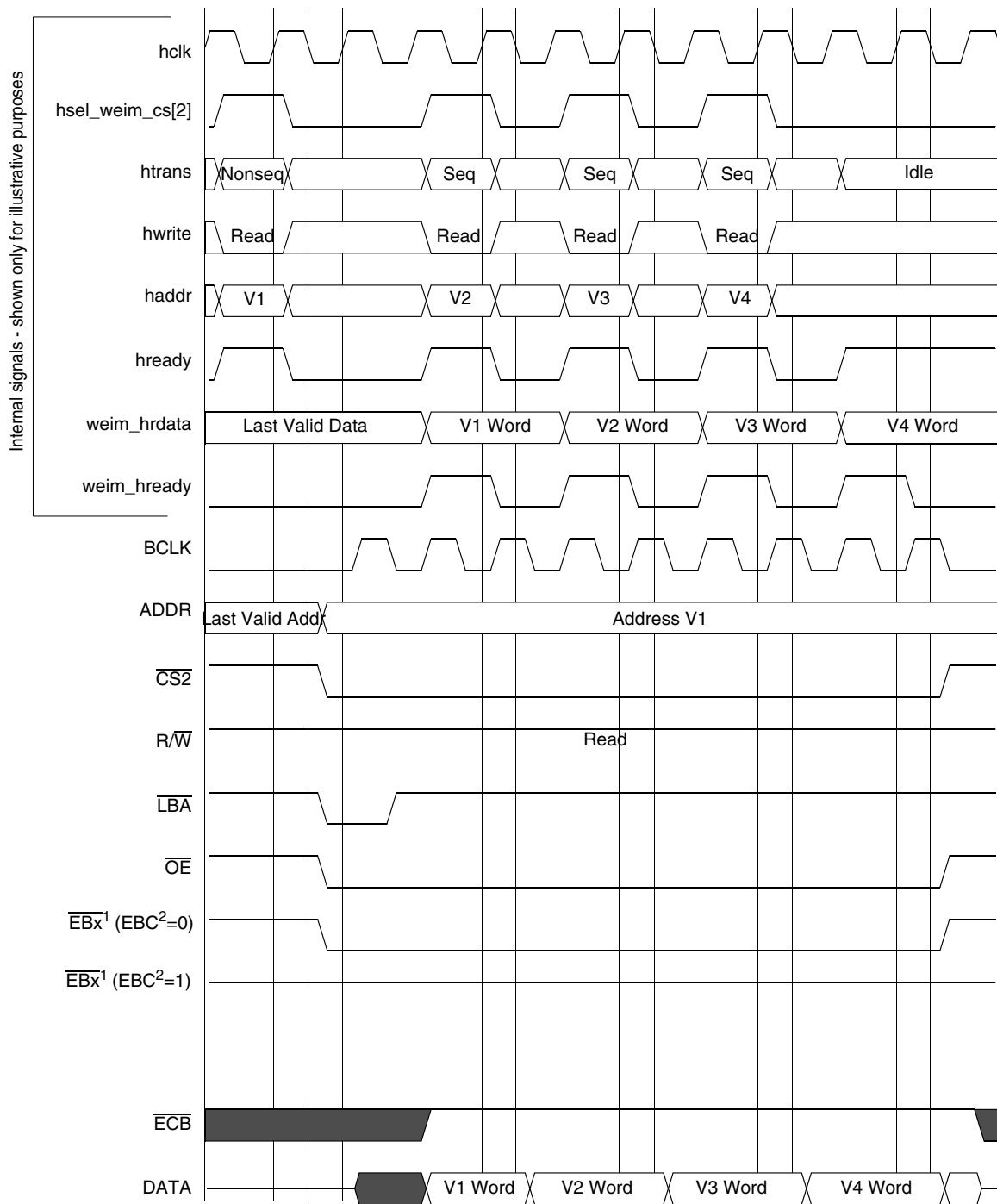

Note 1: x = 0, 1, 2 or 3
 Note 2: EBC = Enable Byte Control bit (bit 11) on the Chip Select Control Register

Figure 29. WSC = 2, SYNC = 1, DOL = [1/0], A.WORD/E.WORD

Specifications

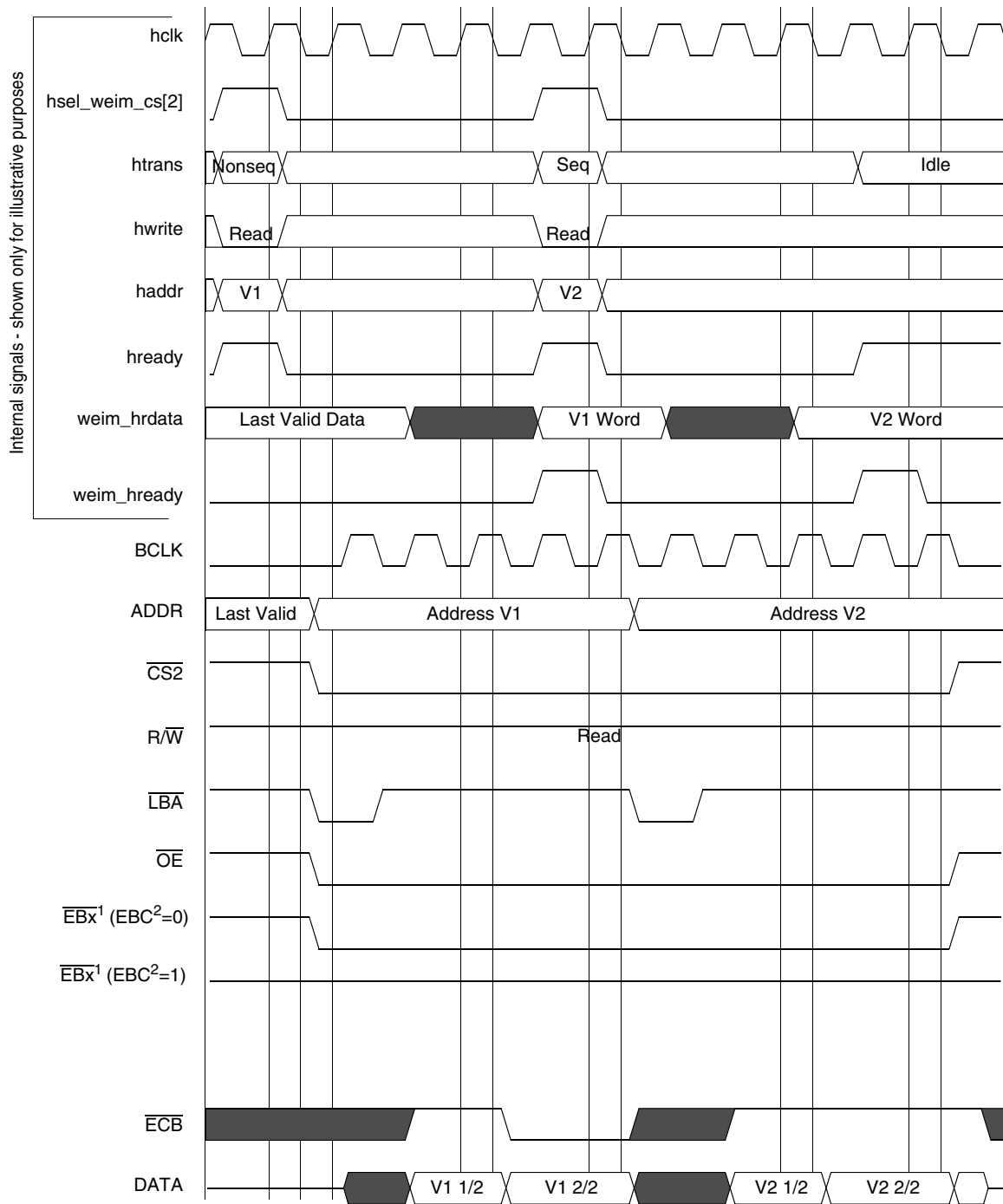

Note 1: x = 0, 1, 2 or 3

Note 2: EBC = Enable Byte Control bit (bit 11) on the Chip Select Control Register

Figure 30. WSC = 2, SYNC = 1, DOL = [1/0], A.WORD/E.HALF

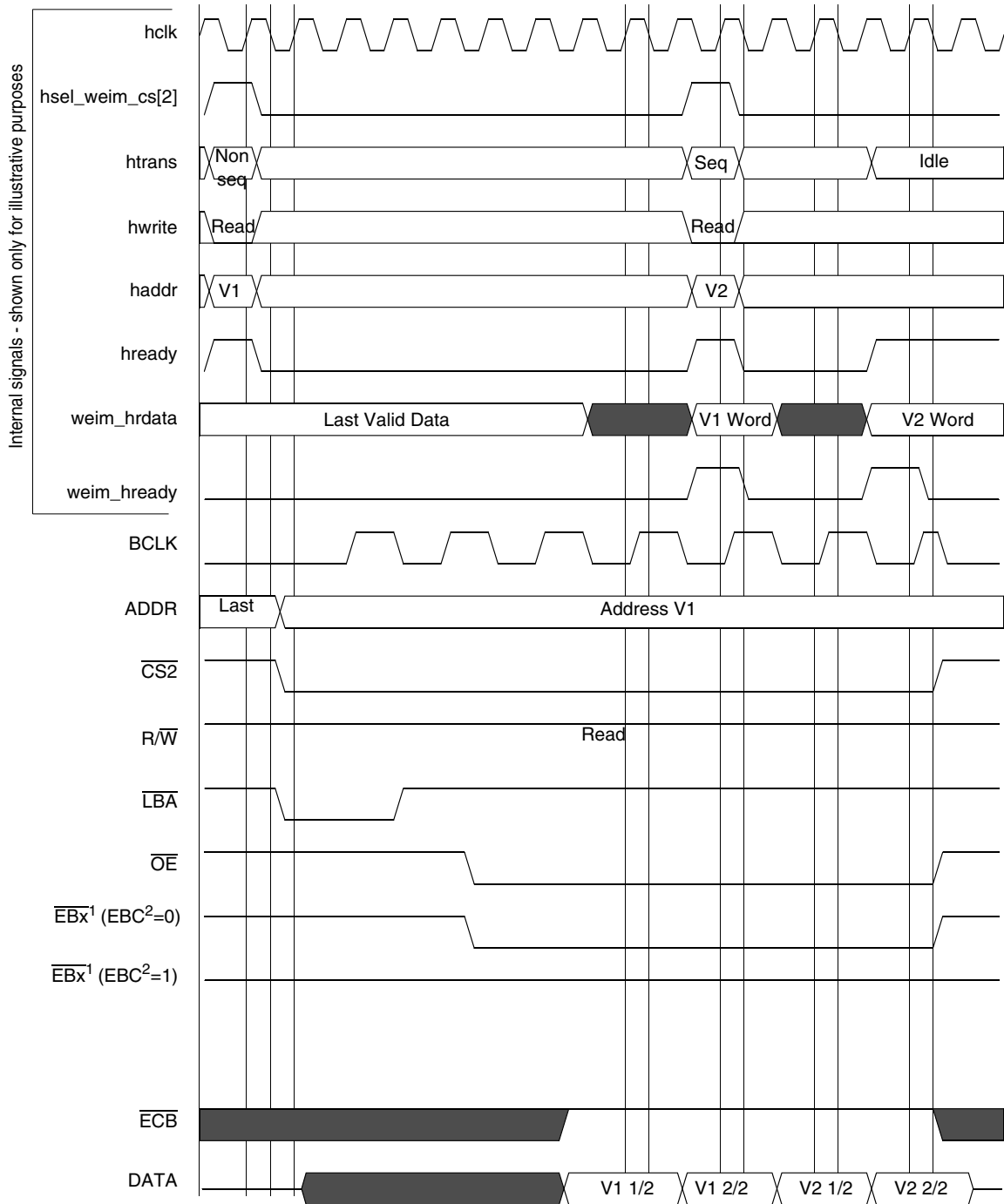

Note 1: x = 0, 1, 2 or 3
 Note 2: EBC = Enable Byte Control bit (bit 11) on the Chip Select Control Register

Figure 31. WSC = 7, OEA = 8, SYNC = 1, DOL = 1, BCD = 1, BCS = 2, A.WORD/E.HALF

Specifications

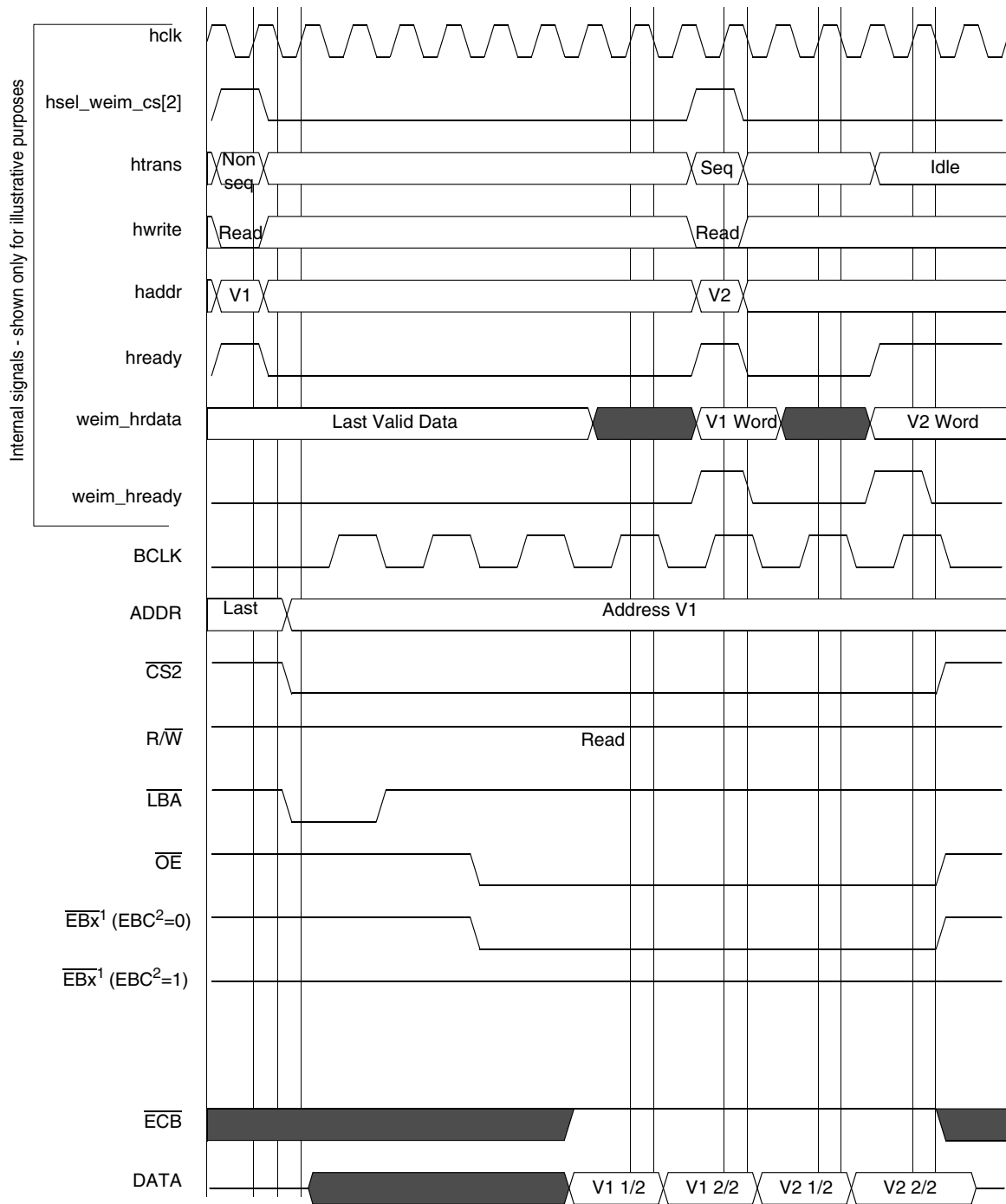

Note 1: x = 0, 1, 2 or 3
 Note 2: EBC = Enable Byte Control bit (bit 11) on the Chip Select Control Register

Figure 32. WSC = 7, OEA = 8, SYNC = 1, DOL = 1, BCD = 1, BCS = 1, A.WORD/E.HALF

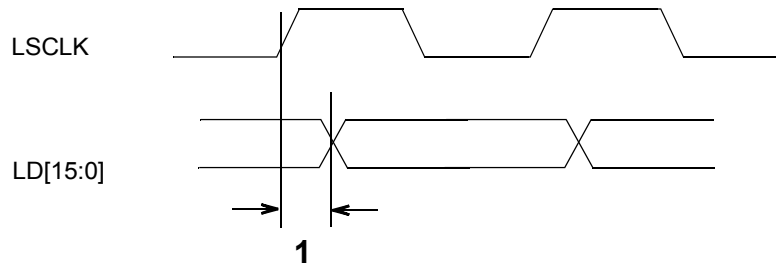

Figure 33. SCLK to LD Timing Diagram

Table 18. LCDC SCLK Timing

Num	Characteristic	3.0 +/- 0.3V		Unit
		Minimum	Maximum	
1	SCLK to LD valid	-	3	ns

3.8.4 Non-TFT Panel Timing

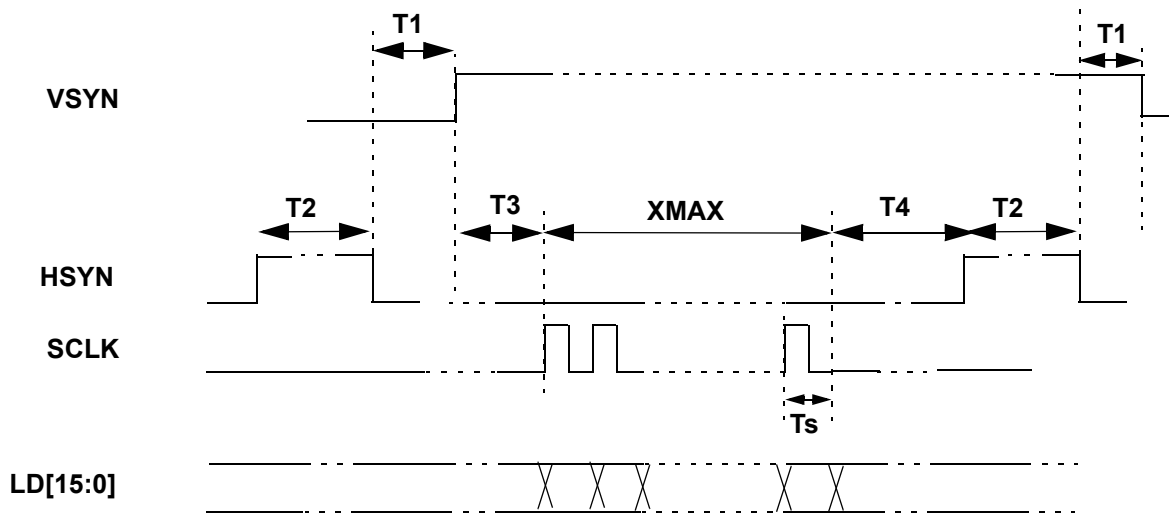

Figure 34. Non-TFT Panel Timing

Table 19. Non TFT Panel Timing Diagram

Symbol	Parameter	Allowed Register Minimum Value	Actual Value	Unit
T1	HSYN to VSYN delay	0	HWAIT2+2	Tpix
T2	HSYN pulse width	0	HWIDTH+1	Tpix
T3	VSYN to SCLK	-	$0 \leq T3 \leq Ts$	-
T4	SCLK to HSYN	0	HWAIT1+1	Tpix

Specifications

- VSYN, HSYN and SCLK can be programmed as active high or active low. In the above timing diagram, all these 3 signals are active high.
- T_s is the shift clock period.
- $T_s = T_{pix} * (\text{panel data bus width})$.
- T_{pix} is the pixel clock period which equals LCDC_CLK period * (PCD + 1).
- Maximum frequency of LCDC_CLK is 48 MHz, which is controlled by Peripheral Clock Divider Register.
- Maximum frequency of SCLK is $HCLK / 5$, otherwise LD output will be wrong.

3.9 Pen ADC Specifications

The specifications for the pen ADC are shown in Table 20 through Table 22.

Table 20. Pen ADC System Performance

Full Range Resolution ¹	13 bits
Non-Linearity Error ¹	4 bits
Accuracy ¹	9 bits

1. Tested under input = 0~1.8V at 25°C

Table 21. Pen ADC Test Conditions

Vp max	1800 mV	ip max	+7 μ A
Vp min	GND	ip min	1.5 μ A
Vn	GND	in	1.5 μ A
Sample frequency	12 MHz		
Sample rate	1.2 KHz		
Input frequency	100 Hz		
Input range	0~1800 mV		
Note: Ru1 = Ru2 = 200K			

Table 22. Pen ADC Absolute Rating

ip max	+9.5 μ A
ip min	-2.5 μ A
in max	+9.5 μ A
in min	-2.5 μ A

3.10 ASP Touch Panel Controller

The following sections contain the electrical specifications of the ASP touch panel controller. The value of parameters and their corresponding measuring conditions are mentioned as well.

3.10.1 Electrical Specifications

Test conditions: Temperature = 25° C, QVDD = 1800mV.

Table 23. ASP Touch Panel Controller Electrical Spec

Parameter	Minimum	Type	Maximum	Unit
Offset	–	32768	–	–
Offset Error	–	–	8199	–

Specifications

Table 23. ASP Touch Panel Controller Electrical Spec (Continued)

Parameter	Minimum	Type	Maximum	Unit
Gain	–	13.65	–	mV ⁻¹
Gain Error	–	–	33%	–
DNL	8	9	–	Bits
INL	–	0	–	Bits
Accuracy (without missing code)	8	9	–	Bits
Operating Voltage Range (Pen)	–	–	QVDD	mV
Operating Voltage Range (U)	Negative QVDD	–	QVDD	mV
On-resistance of switches SW[8:1]	–	10	–	Ohm

Note that QVDD should be 1800mV.

3.10.2 Gain Calculations

The ideal mapping of input voltage to output digital sample is defined as follows:

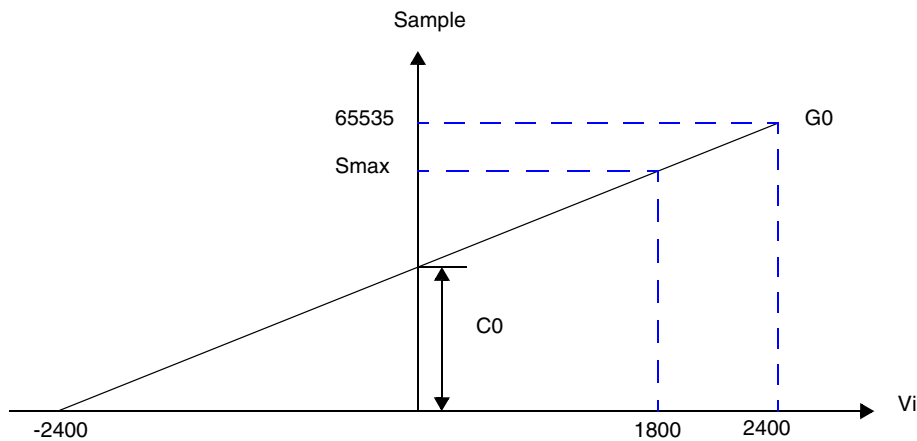

Figure 35. Gain Calculations

In general, the mapping function is:

$$S = G * V + C$$

Where V is input, S is output, G is the slope, and C is the y-intercept.

$$\text{Nominal Gain } G_0 = 65535 / 4800 = 13.65\text{mV}^{-1}$$

$$\text{Nominal Offset } C_0 = 65535 / 2 = 32767$$

3.10.3 Offset Calculations

The ideal mapping of input voltage to output digital sample is defined as:

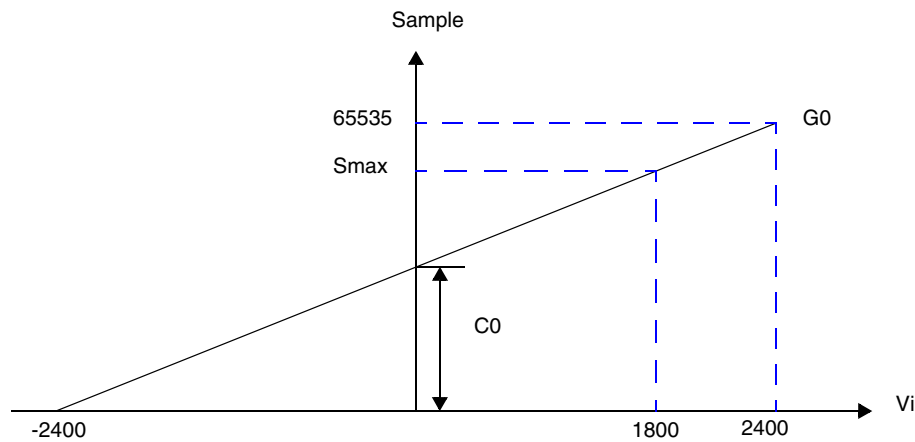

Figure 36. Offset Calculations

In general, the mapping function is:

$$S = G * V + C$$

Where V is input, S is output, G is the slope, and C is the y-intercept.

$$\text{Nominal Gain } G_0 = 65535 / 4800 = 13.65\text{mV}^{-1}$$

$$\text{Nominal Offset } C_0 = 65535 / 2 = 32767$$

3.10.4 Gain Error Calculations

Gain error calculations are made using the information in this section.

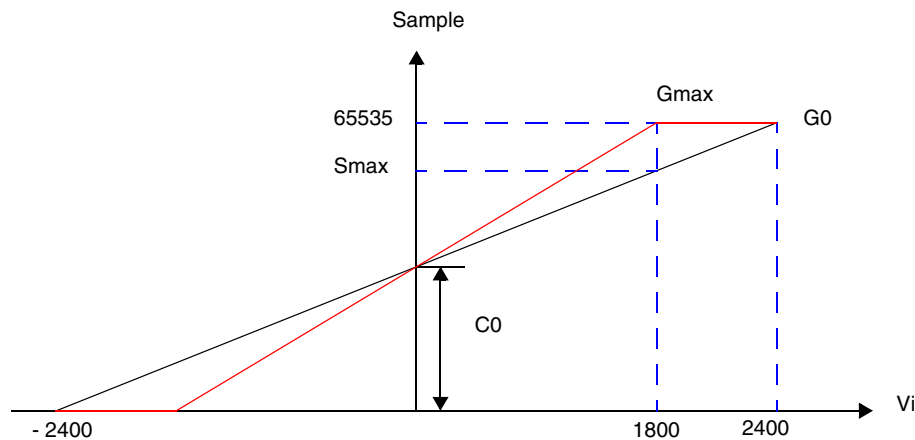

Figure 37. Gain Error Calculations

Assuming the offset remains unchanged, the mapping is rotated around y-intercept to determine the maximum gain allowed. This occurs when the sample at 1800mV has just reached the ceiling of the 16-bit range, 65535.

Specifications

Maximum Offset G_{\max} ,

$$\begin{aligned} G_{\max} &= (65535 - C_0) / 1800 \\ &= (65535 - 32767) / 1800 \\ &= 18.20 \end{aligned}$$

Gain Error G_r ,

$$\begin{aligned} G_r &= (G_{\max} - G_0) / G_0 * 100\% \\ &= (18.20 - 13.65) / 13.65 * 100\% \\ &= 33\% \end{aligned}$$

3.11 Bluetooth Accelerator

The Bluetooth Accelerator (BTA) radio interface supports the Motorola Radio, MC13180 using an SPI interface. This section provides the data bus timing diagrams and SPI interface timing diagrams shown in Figure 38 and Figure 39 on page 57, and the associated parameters shown in Table 24 and Table 25 on page 57.

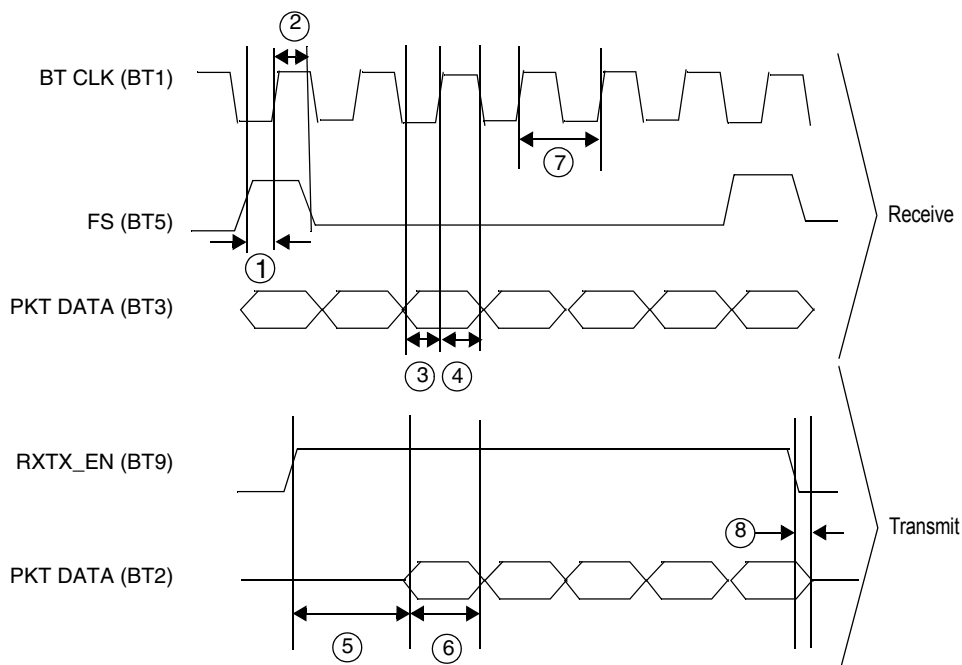

Figure 38. Motorola MC13180 Data Bus Timing Diagram

Table 24. Motorola MC13180 Data Bus Timing Parameter Table

Ref No.	Parameter	Minimum	Typical	Maximum	Unit
1	FrameSync setup time relative to BT CLK rising edge ¹	–	4	–	ns
2	FrameSync hold time relative to BT CLK rising edge ¹	–	12	–	ns
3	Receive Data setup time relative to BT CLK rising edge ¹	–	6	–	ns
4	Receive Data hold time relative to BT CLK rising edge ¹	–	13	–	ns
5	Transmit Data setup time relative to RXTX_EN rising edge ²	172.5	–	192.5	μs

Table 24. Motorola MC13180 Data Bus Timing Parameter Table (Continued)

Ref No.	Parameter	Minimum	Typical	Maximum	Unit
6	TX DATA period	1000 +/- 0.02			ns
7	BT CLK duty cycle	40	–	60	%
8	Transmit Data hold time relative to RXTX_EN falling edge	4	–	10	µs

1. Please refer to Motorola 2.4 GHz RF Transceiver Module (MC13180) Technical Data documentation.
2. The setup and hold times of RX_TX_EN can be adjusted by programming Time_A_B register (0x00216050) and RF_Status (0x0021605C) registers.

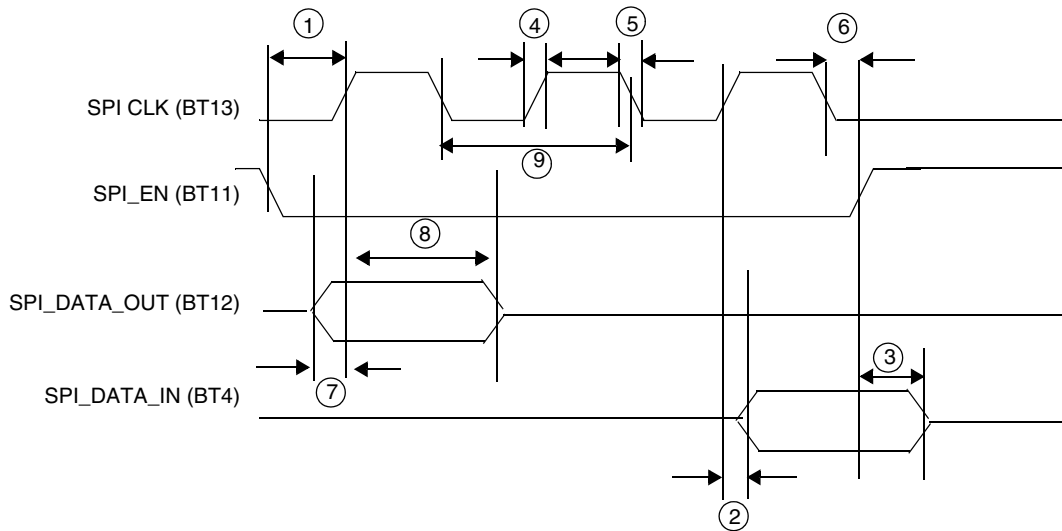

Figure 39. SPI Interface Timing Diagram Using Motorola MC13180

Table 25. SPI Interface Timing Parameter Table Using Motorola MC13180

Ref No.	Parameter	Minimum	Maximum	Unit
1	SPI_EN setup time relative to rising edge of SPI_CLK	15	–	ns
2	Transmit data delay time relative to rising edge of SPI_CLK	0	15	ns
3	Transmit data hold time relative to rising edge of SPI_EN	0	15	ns
4	SPI_CLK rise time	0	25	ns
5	SPI_CLK fall time	0	25	ns
6	SPI_EN hold time relative to falling edge of SPI_CLK	15	–	ns
7	Receive data setup time relative to falling edge of SPI_CLK ¹	15	–	ns
8	Receive data hold time relative to falling edge of SPI_CLK ¹	15	–	ns
9	SPI_CLK frequency, 50% duty cycle required ¹	–	20	MHz

1. The SPI_CLK clock frequency and duty cycle, setup and hold times of receive data can be set by programming SPI_Control (0x00216138) register together with system clock.

3.12 SPI Timing Diagrams

To use the internal transmit (TX) and receive (RX) data FIFOs when the SPI 1 module is configured as a master, two control signals are used for data transfer rate control: the \overline{SS} signal (output) and the $\overline{SPI_RDY}$ signal (input). The SPI 1 Sample Period Control Register (PERIODREG1) and the SPI 2 Sample Period Control Register (PERIODREG2) can also be programmed to a fixed data transfer rate for either SPI 1 or SPI 2. When the SPI 1 module is configured as a slave, the user can configure the SPI 1 Control Register (CONTROLREG1) to match the external SPI master's timing. In this configuration, \overline{SS} becomes an input signal, and is used to latch data into or load data out to the internal data shift registers, as well as to increment the data FIFO.

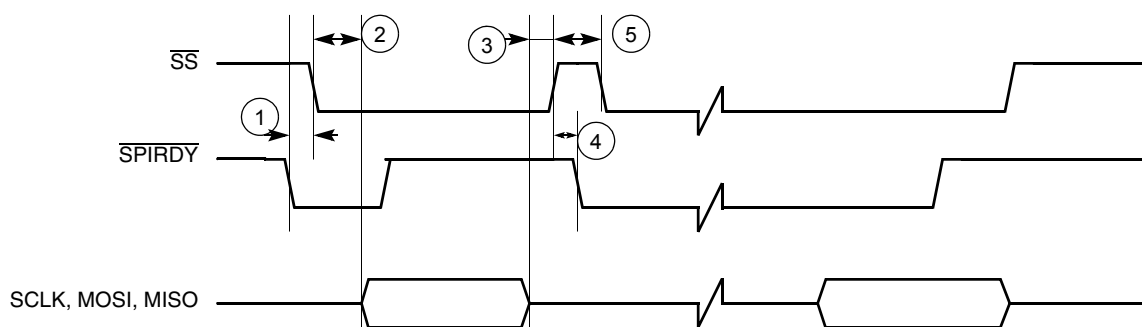

Figure 40. Master SPI Timing Diagram Using $\overline{SPI_RDY}$ Edge Trigger

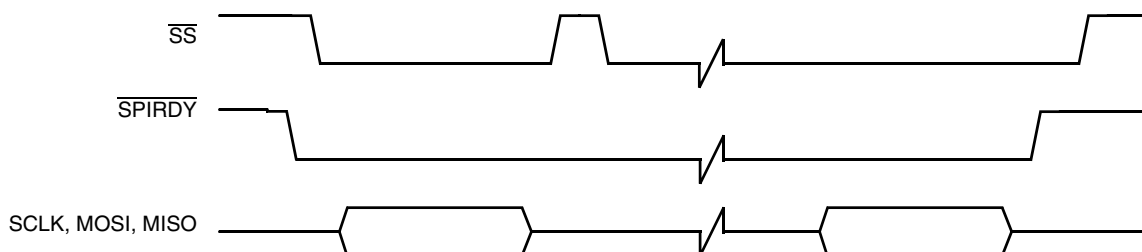

Figure 41. Master SPI Timing Diagram Using $\overline{SPI_RDY}$ Level Trigger

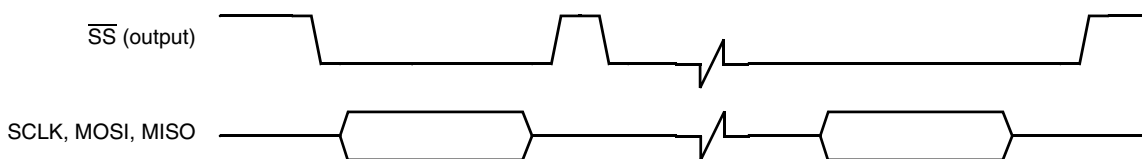

Figure 42. Master SPI Timing Diagram Ignore $\overline{SPI_RDY}$ Level Trigger

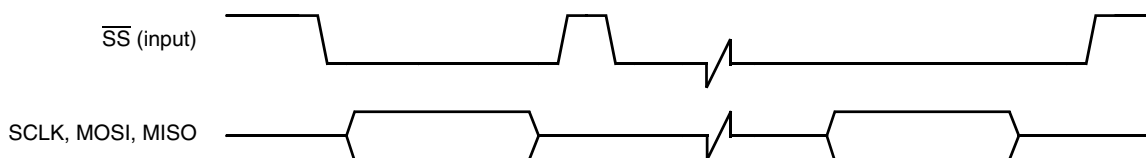

Figure 43. Slave SPI Timing Diagram FIFO Advanced by BIT COUNT

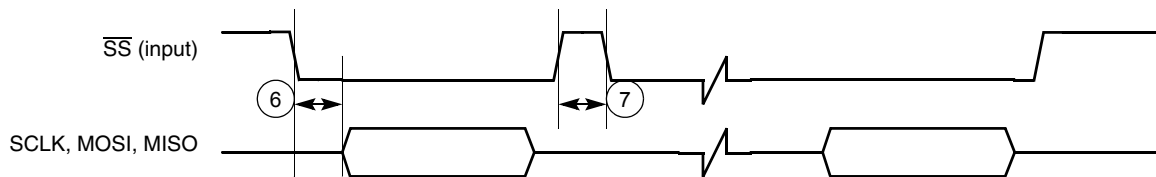

Figure 44. Slave SPI Timing Diagram FIFO Advanced by \overline{SS} Rising Edge

Table 26. Timing Parameter Table for Figure 40 through Figure 44

Ref No.	Parameter	Minimum	Maximum	Unit
1	$\overline{SPI_RDY}$ to \overline{SS} output low	$2T^1$	–	ns
2	\overline{SS} output low to first SCLK edge	$3 \cdot T_{sclk}^2$	–	ns
3	Last SCLK edge to \overline{SS} output high	$2 \cdot T_{sclk}$	–	ns
4	\overline{SS} output high to $\overline{SPI_RDY}$ low	0	–	ns
5	\overline{SS} output pulse width	$T_{sclk} + WAIT^3$	–	ns
6	\overline{SS} input low to first SCLK edge	T	–	ns
7	\overline{SS} input pulse width	T	–	ns

1. T = CSPI system clock period (PERCLK2).
2. T_{sclk} = Period of SCLK.
3. WAIT = Number of bit clocks (SCLK) or 32.768 KHz clocks per Sample Period Control Register.

3.13 LCD Controller

This section includes timing diagrams for the LCD controller. For detailed timing diagrams of the LCD controller with various display configurations, refer to the LCD controller chapter of the *MC9328MX1 Reference Manual*.

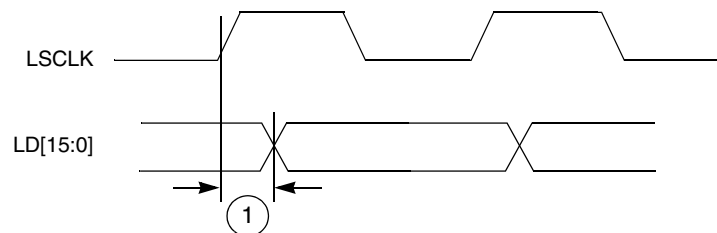

Figure 45. SCLK to LD Timing Diagram

Table 27. LCDC SCLK Timing Parameter Table

Ref No.	Parameter	Minimum	Maximum	Unit
1	SCLK to LD valid	–	2	ns

Specifications

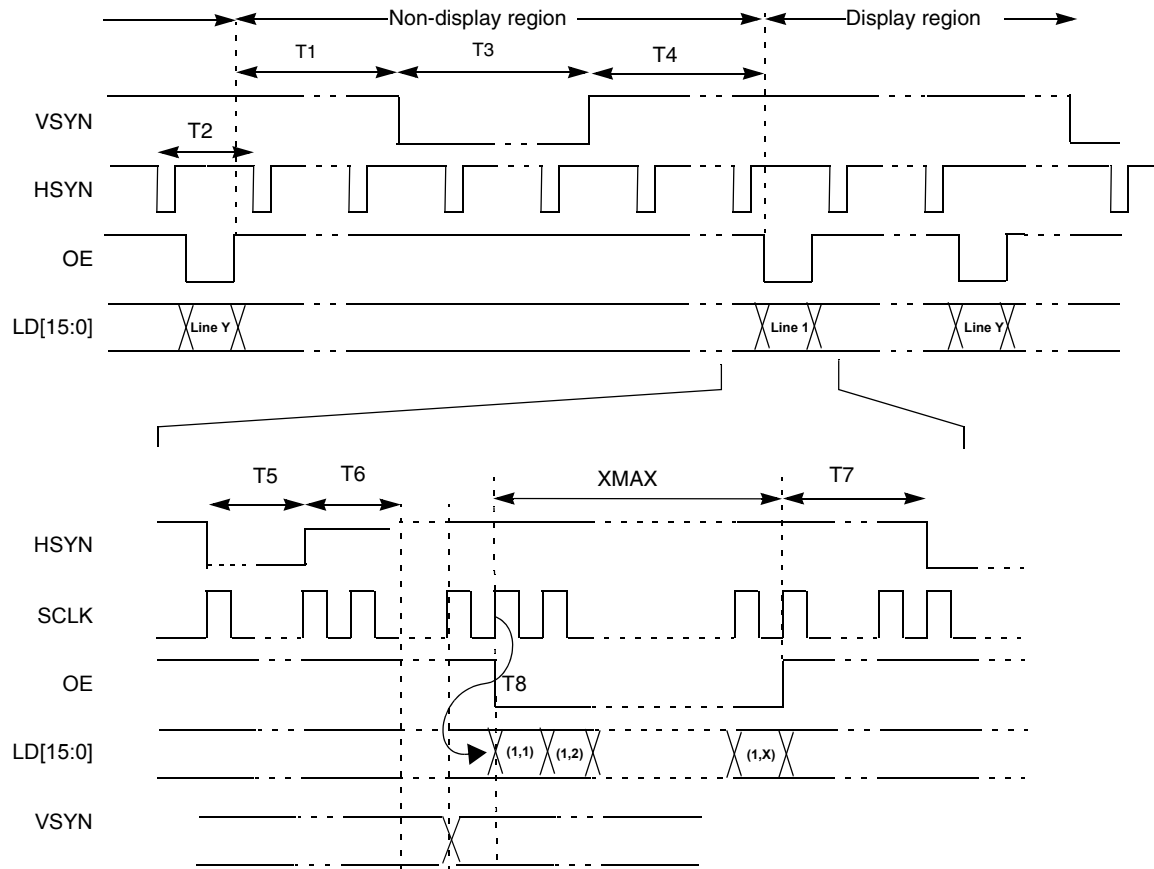

Figure 46. 4/8/16 Bit/Pixel TFT Color Mode Panel Timing Diagram

Table 28. 4/8/16 Bit/Pixel TFT Color Mode Panel Timing Table

Symbol	Description	Minimum	Corresponding Register Value	Unit
T1	End of OE to beginning of VSYN	$T5+T6+T7+T9$	$(VWAIT1 \cdot T2)+T5+T6+T7+T9$	Ts
T2	HSYN period	$XMAX+5$	$XMAX+T5+T6+T7+T9+T10$	Ts
T3	VSYN pulse width	T2	$VWIDTH \cdot (T2)$	Ts
T4	End of VSYN to beginning of OE	2	$VWAIT2 \cdot (T2)$	Ts
T5	HSYN pulse width	1	$HWIDTH+1$	Ts
T6	End of HSYN to beginning to T9	1	$HWAIT2+1$	Ts
T7	End of OE to beginning of HSYN	1	$HWAIT1+1$	Ts
T8	SCLK to valid LD data	-3	3	ns
T9	End of HSYN idle2 to VSYN edge (for non-display region)	2	2	Ts
T9	End of HSYN idle2 to VSYN edge (for Display region)	1	1	Ts

Table 28. 4/8/16 Bit/Pixel TFT Color Mode Panel Timing Table (Continued)

Symbol	Description	Minimum	Corresponding Register Value	Unit
T10	VSYN to OE active (Sharp = 0), when VWAIT2 = 0	1	1	Ts
T10	VSYN to OE active (Sharp = 1), when VWAIT2 = 0	2	2	Ts

Note:

- Ts is the SCLK period which equals $\text{LCD_CLK} / (\text{PCD} + 1)$. Normally $\text{LCD_CLK} = 15\text{ns}$.
- VSYN, HSYN and OE can be programmed as active high or active low. In Figure 46, all 3 signals are active low.
- The polarity of SCLK and LD[15:0] can also be programmed.
- SCLK can be programmed to be deactivated during the VSYN pulse or the OE deasserted period. In Figure 46, SCLK is always active.
- For T9 non-display region, VSYN is non-active. It is used as a reference.
- XMAX is defined in pixels.

3.14 Multimedia Card/Secure Digital Host Controller

The DMA interface block controls all data routing between the external data bus (DMA access), internal MMC/SD module data bus, and internal system FIFO access through a dedicated state machine that monitors the status of FIFO content (empty or full), FIFO address, and byte/block counters for the MMC/SD module (inner system) and the application (user programming).

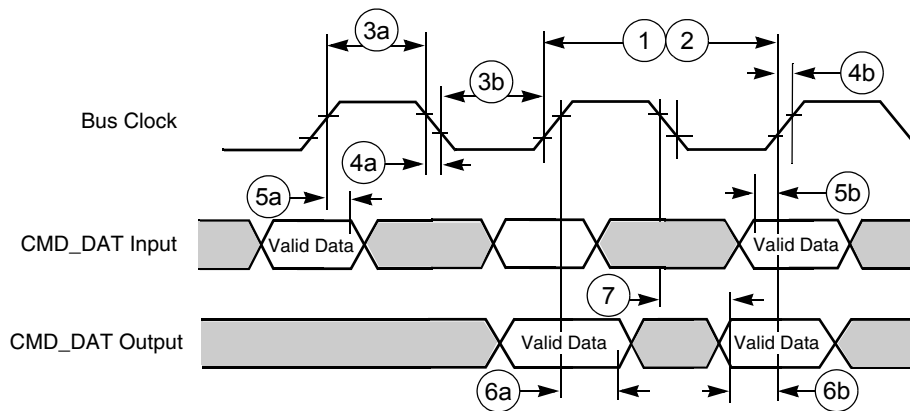

Figure 47. Chip-Select Read Cycle Timing Diagram

Table 29. SDHC Bus Timing Parameter Table

Ref No.	Parameter	1.8V +/- 0.10V		3.0V +/- 0.30V		Unit
		Min	Max	Min	Max	
1	CLK frequency at Data transfer Mode (PP) ¹ —10/30 cards	0	25/5	0	25/5	MHz
2	$\overline{\text{CLK}}$ frequency at Identification Mode ²	0	400	0	400	KHz
3a	Clock high time ¹ —10/30 cards	6/33	—	10/50	—	ns

Specifications

Table 29. SDHC Bus Timing Parameter Table (Continued)

Ref No.	Parameter	1.8V +/- 0.10V		3.0V +/- 0.30V		Unit
		Min	Max	Min	Max	
3b	Clock low time ¹ —10/30 cards	15/75	—	10/50	—	ns
4a	Clock fall time ¹ —10/30 cards	—	10/50 (5.00) ³	—	10/50	ns
4b	Clock rise time ¹ —10/30 cards	—	14/67 (6.67) ³	—	10/50	ns
5a	Input hold time ³ —10/30 cards	5.7/5.7	—	5/5	—	ns
5b	Input setup time ³ —10/30 cards	5.7/5.7	—	5/5	—	ns
6a	Output hold time ³ —10/30 cards	5.7/5.7	—	5/5	—	ns
6b	Output setup time ³ —10/30 cards	5.7/5.7	—	5/5	—	ns
7	Output delay time ³	0	16	0	14	ns

1. $C_L \leq 100$ pF / 250 pF (10/30 cards)
2. $C_L \leq 250$ pF (21 cards)
3. $C_L \leq 25$ pF (1 card)

3.14.1 Command Response Timing on MMC/SD Bus

The card identification and card operation conditions timing are processed in open-drain mode. The card response to the host command starts after exactly N_{ID} clock cycles. For the card address assignment, SET_RCA is also processed in the open-drain mode. The minimum delay between the host command and card response is NCR clock cycles as illustrated in Figure 48. The symbols for Figure 48 through Figure 52 are defined in Table 30.

Table 30. State Signal Parameters for Figure 48 through Figure 52

Card Active		Host Active	
Symbol	Definition	Symbol	Definition
Z	High impedance state	S	Start bit (0)
D	Data bits	T	Transmitter bit (Host = 1, Card = 0)
*	Repetition	P	One-cycle pull-up (1)
CRC	Cyclic redundancy check bits (7 bits)	E	End bit (1)

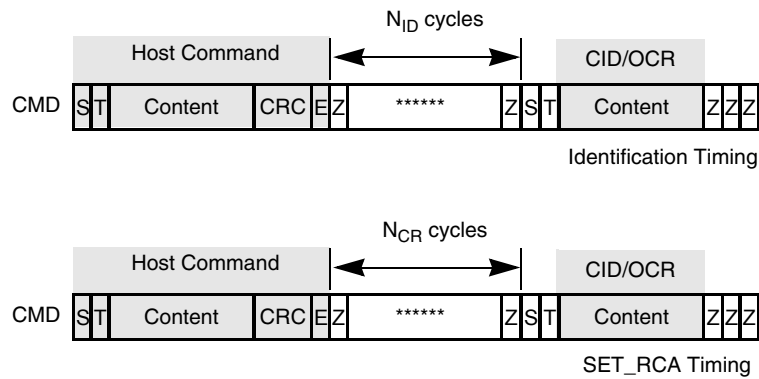

Figure 48. Timing Diagrams at Identification Mode

After a card receives its RCA, it switches to data transfer mode. As shown on the first diagram in Figure 49 on page 63, SD_CMD lines in this mode are driven with push-pull drivers. The command is followed by a period of two Z bits (allowing time for direction switching on the bus) and then by P bits pushed up by the responding card. The other two diagrams show the separating periods N_{RC} and N_{CC} .

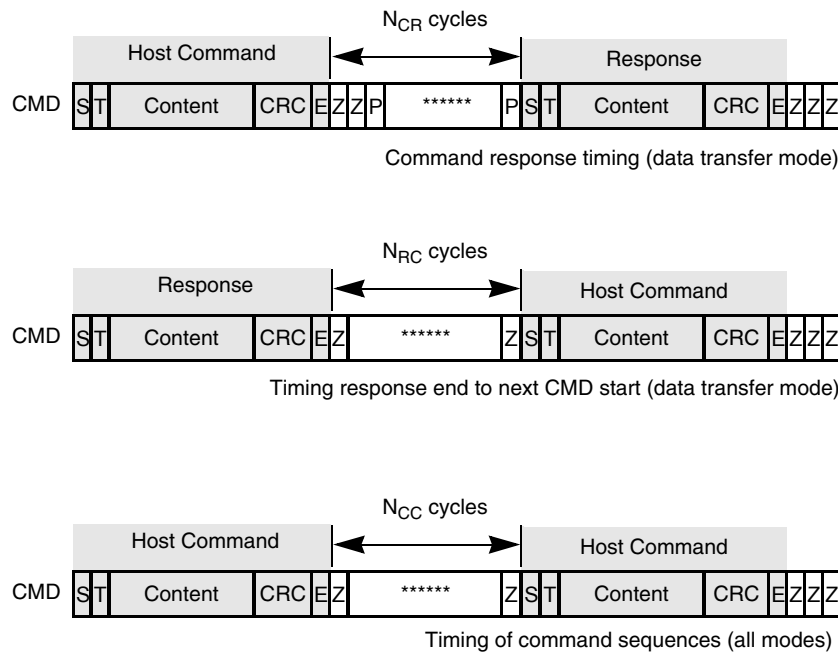

Figure 49. Timing Diagrams at Data Transfer Mode

Figure 50 on page 64 shows basic read operation timing. In a read operation, the sequence starts with a single block read command (which specifies the start address in the argument field). The response is sent on the SD_CMD lines as usual. Data transmission from the card starts after the access time delay N_{AC} , beginning from the last bit of the read command. If the system is in multiple block read mode, the card sends a continuous flow of data blocks with distance N_{AC} until the card sees a stop transmission command. The data stops two clock cycles after the end bit of the stop command.

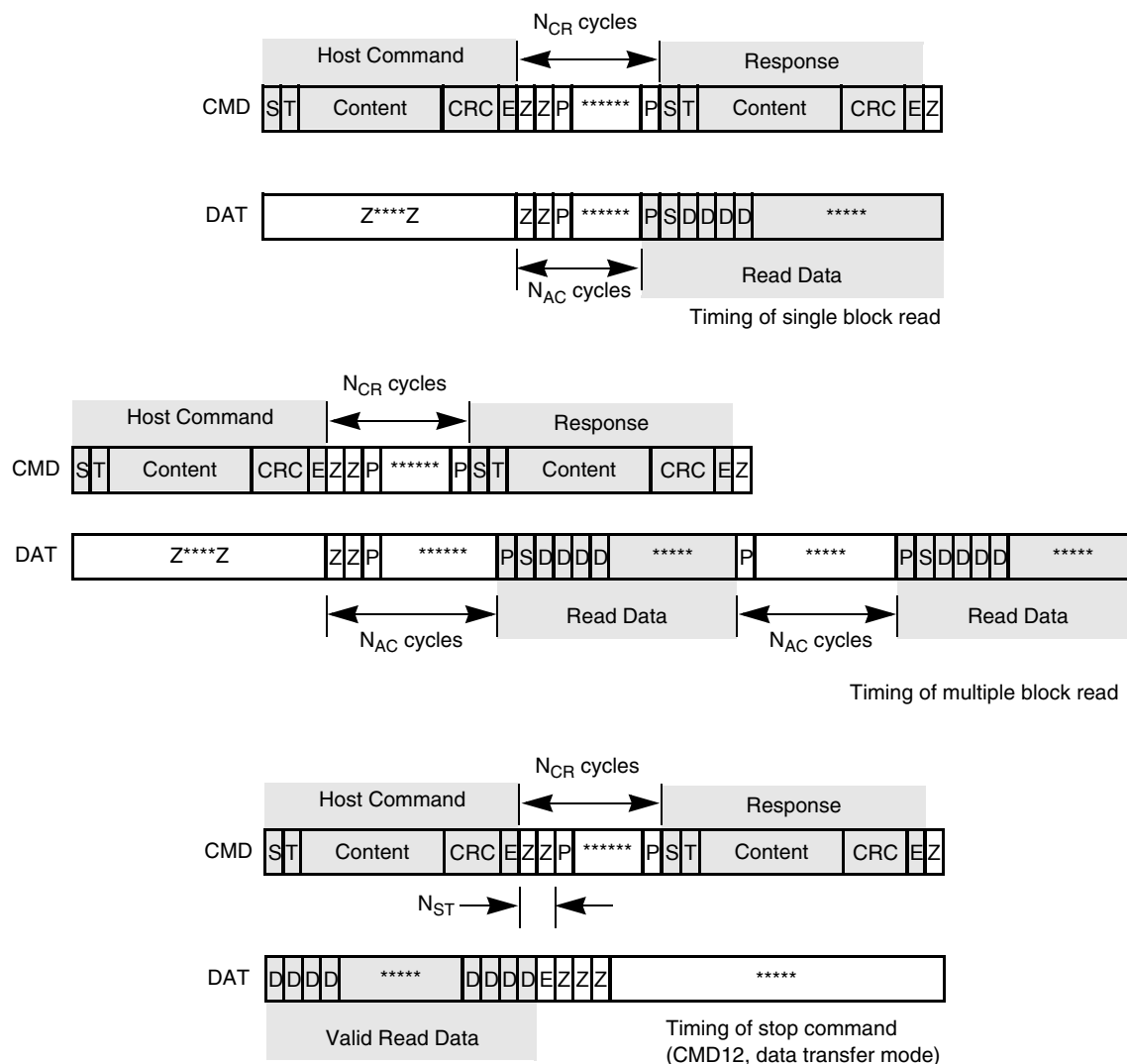

Figure 50. Timing Diagrams at Data Read

Figure 51 on page 65 shows the basic write operation timing. As with the read operation, after the card response, the data transfer starts after N_{WR} cycles. The data is suffixed with CRC check bits to allow the card to check for transmission errors. The card sends back the CRC check result as a CC status token on the data line. If there was a transmission error, the card sends a negative CRC status (101); otherwise, a positive CRC status (010) is returned. The card expects a continuous flow of data blocks if it is configured to multiple block mode, with the flow terminated by a stop transmission command.

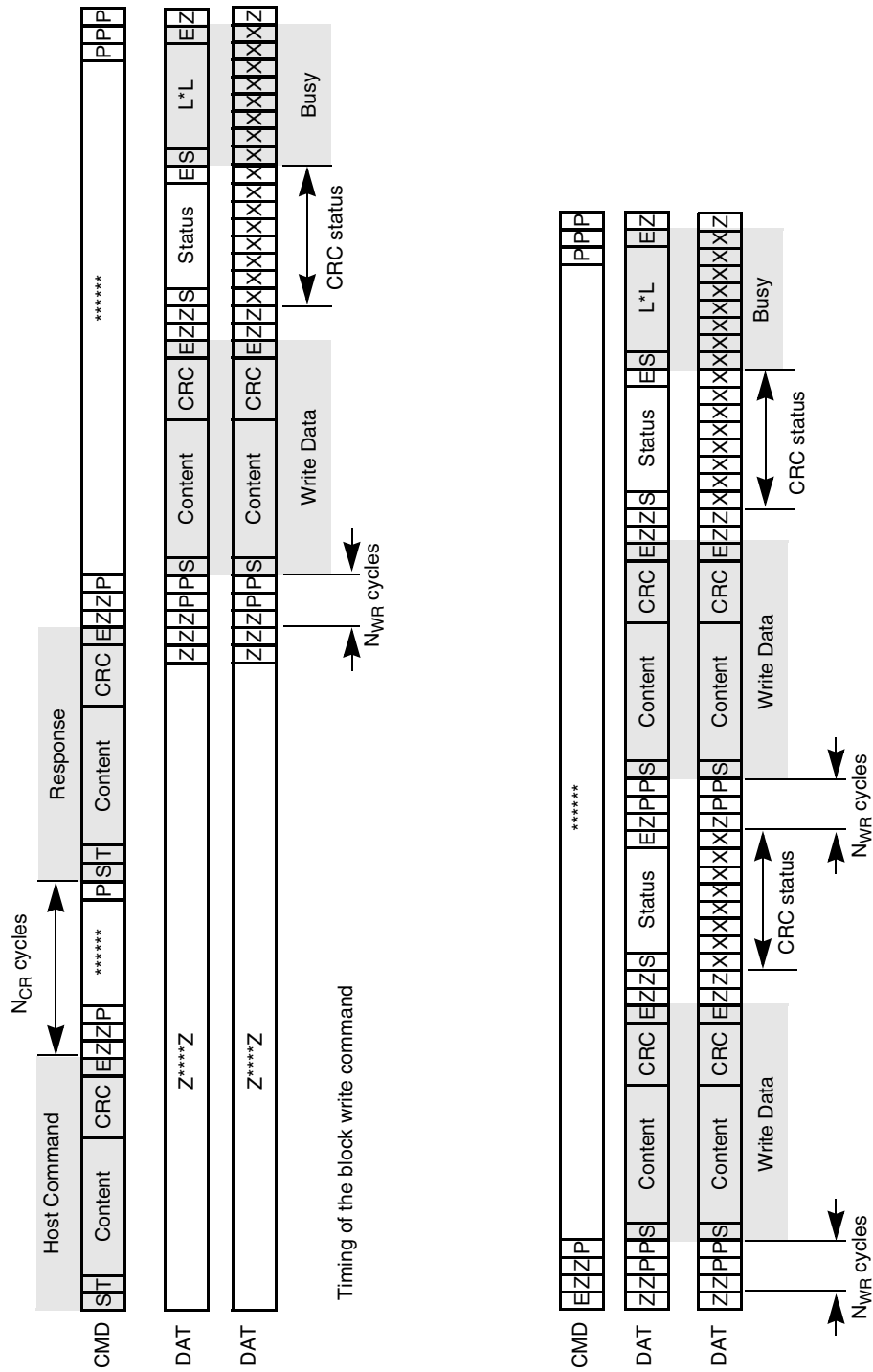

Figure 51. Timing Diagrams at Data Write

Table 31. Timing Values for Figure 48 through Figure 52

Parameter	Symbol	Minimum	Maximum	Unit
MMC/SD bus clock, CLK (All values are referred to minimum (VIH) and maximum (VIL))				
Command response cycle	NCR	2	64	Clock cycles
Identification response cycle	NID	5	5	Clock cycles
Access time delay cycle	NAC	2	TAAC + NSAC	Clock cycles
Command read cycle	NRC	8	–	Clock cycles
Command-command cycle	NCC	8	–	Clock cycles
Command write cycle	NWR	2	–	Clock cycles
Stop transmission cycle	NST	2	2	Clock cycles
TAAC: Data read access time -1 defined in CSD register bit[119:112] NSAC: Data read access time -2 in CLK cycles (NSAC·100) defined in CSD register bit[111:104]				

3.14.2 SDIO-IRQ and ReadWait Service Handling

In SDIO, there is a 1-bit or 4-bit interrupt response from the SDIO peripheral card. In 1-bit mode, the interrupt response is simply that the SD_DAT[1] line is held low. The SD_DAT[1] line is not used as data in this mode. The memory controller generates an interrupt according to this low and the system interrupt continues until the source is removed (SD_DAT[1] returns to its high level).

In 4-bit mode, the interrupt is less simple. The interrupt triggers at a particular period called the "Interrupt Period" during the data access, and the controller must sample SD_DAT[1] during this short period to determine the IRQ status of the attached card. The interrupt period only happens at the boundary of each block (512 bytes).

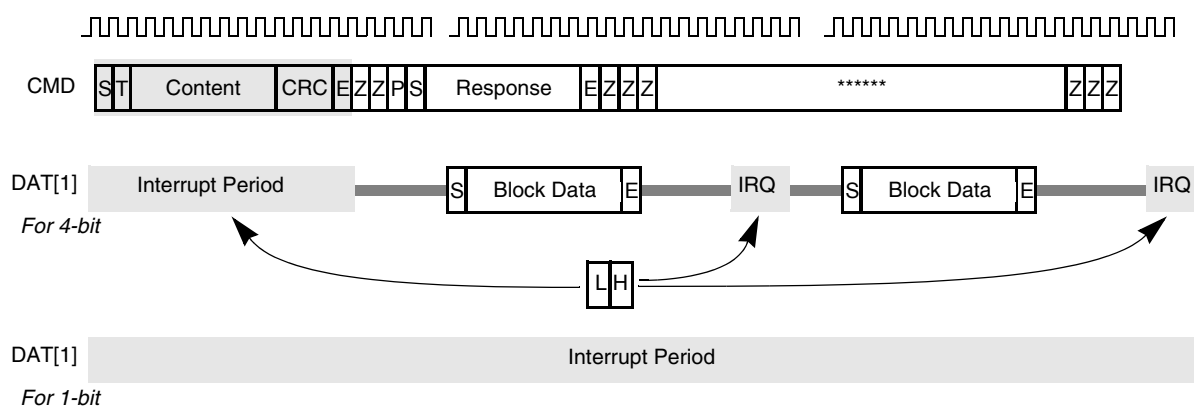

Figure 53. SDIO IRQ Timing Diagram

ReadWait is another feature in SDIO that allows the user to submit commands during the data transfer. In this mode, the block temporarily pauses the data transfer operation counter and related status, yet keeps the clock running, and allows the user to submit commands as normal. After all commands are submitted, the user can switch back to the data transfer operation and all counter and status values are resumed as access continues.

Specifications

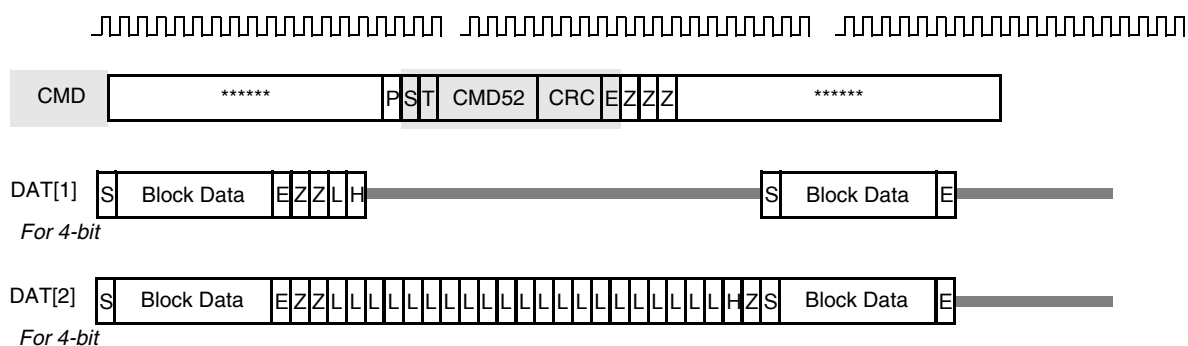

Figure 54. SDIO ReadWait Timing Diagram

3.15 Memory Stick Host Controller

The Memory Stick protocol requires three interface signal line connections for data transfers: MS_BS, MS_SDIO, and MS_SCLKO. Communication is always initiated by the MSHC and operates the bus in either four-state or two-state access mode.

The MS_BS signal classifies data on the SDIO into one of four states (BS0, BS1, BS2, or BS3) according to its attribute and transfer direction. BS0 is the INT transfer state, and during this state no packet transmissions occur. During the BS1, BS2, and BS3 states, packet communications are executed. The BS1, BS2, and BS3 states are regarded as one packet length and one communication transfer is always completed within one packet length (in four-state access mode).

The Memory Stick usually operates in four state access mode and in BS1, BS2, and BS3 bus states. When an error occurs during packet communication, the mode is shifted to two-state access mode, and the BS0 and BS1 bus states are automatically repeated to avoid a bus collision on the SDIO.

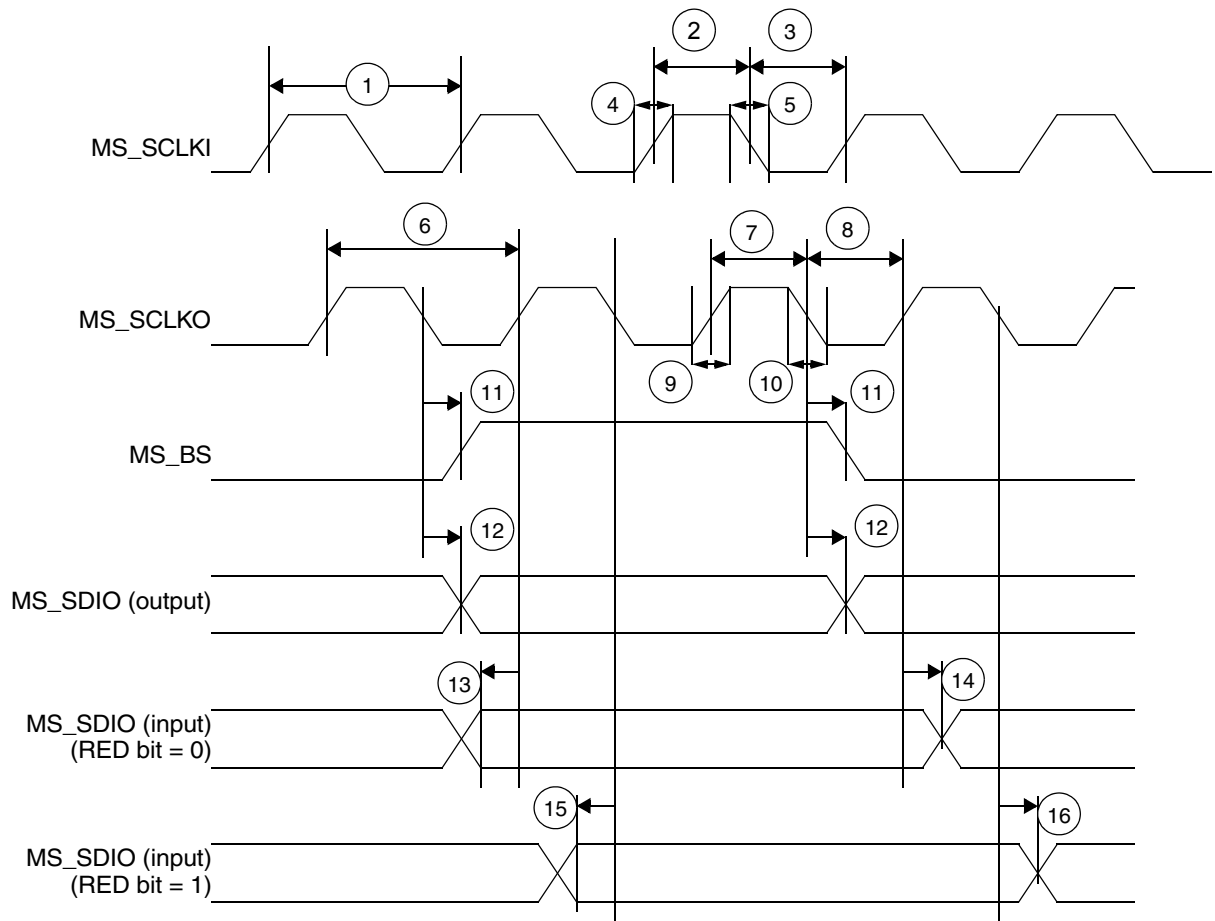

Figure 55. MSHC Signal Timing Diagram

Table 32. MSHC Signal Timing Parameter Table

Ref No.	Parameter	Minimum	Maximum	Unit
1	MS_SCLKI frequency	–	25	MHz
2	MS_SCLKI high pulse width	20	–	ns
3	MS_SCLKI low pulse width	20	–	ns
4	MS_SCLKI rise time	–	3	ns
5	MS_SCLKI fall time	–	3	ns
6	MS_SCLKO frequency ¹	–	25	MHz
7	MS_SCLKO high pulse width ¹	20	–	ns
8	MS_SCLKO low pulse width ¹	15	–	ns
9	MS_SCLKO rise time ¹	–	5	ns
10	MS_SCLKO fall time ¹	–	5	ns
11	MS_BS delay time ¹	–	3	ns

Specifications

Table 32. MSHC Signal Timing Parameter Table (Continued)

Ref No.	Parameter	Minimum	Maximum	Unit
12	MS_SDIO output delay time ^{1,2}	–	3	ns
13	MS_SDIO input setup time for MS_SCLKO rising edge (RED bit = 0) ³	18	–	ns
14	MS_SDIO input hold time for MS_SCLKO rising edge (RED bit = 0) ³	0	–	ns
15	MS_SDIO input setup time for MS_SCLKO falling edge (RED bit = 1) ⁴	23	–	ns
16	MS_SDIO input hold time for MS_SCLKO falling edge (RED bit = 1) ⁴	0	–	ns

1. Loading capacitor condition is less than or equal to 30pF.
2. An external resistor (100 ~ 200 ohm) should be inserted in series to provide current control on the MS_SDIO pin, because of a possibility of signal conflict between the MS_SDIO pin and Memory Stick SDIO pin when the pin direction changes.
3. If the MSC2[RED] bit = 0, MSHC samples MS_SDIO input data at MS_SCLKO rising edge.
4. If the MSC2[RED] bit = 1, MSHC samples MS_SDIO input data at MS_SCLKO falling edge.

3.16 Pulse-Width Modulator

The PWM can be programmed to select one of two clock signals as its source frequency. The selected clock signal is passed through a divider and a prescaler before being input to the counter. The output is available at the pulse-width modulator output (PWMO) external pin.

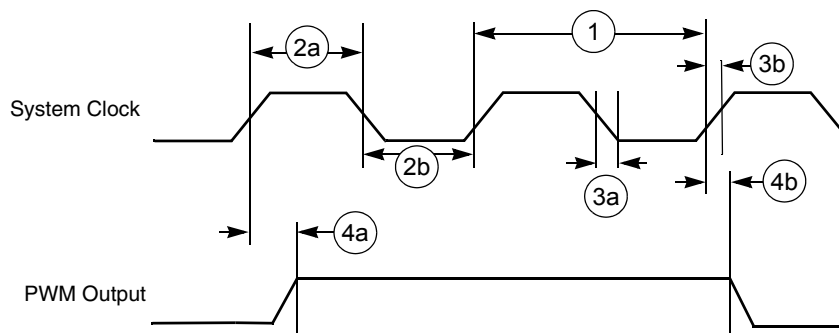

Figure 56. PWM Output Timing Diagram

Table 33. PWM Output Timing Parameter Table

Ref No.	Parameter	1.8V +/- 0.10V		3.0V +/- 0.30V		Unit
		Minimum	Maximum	Minimum	Maximum	
1	System CLK frequency ¹	0	87	0	100	MHz
2a	Clock high time ¹	3.3	–	5/10	–	ns
2b	Clock low time ¹	7.5	–	5/10	–	ns
3a	Clock fall time ¹	–	5	–	5/10	ns
3b	Clock rise time ¹	–	6.67	–	5/10	ns

Table 33. PWM Output Timing Parameter Table (Continued)

Ref No.	Parameter	1.8V +/- 0.10V		3.0V +/- 0.30V		Unit
		Minimum	Maximum	Minimum	Maximum	
4a	Output delay time ¹	5.7	–	5	–	ns
4b	Output setup time ¹	5.7	–	5	–	ns

1. C_L of PWMO = 30 pF

3.17 SDRAM Memory Controller

A write to an address within the memory region initiates the program sequence. The first command issued to the SyncFlash is Load Command Register. A [7:0] determine which operation the command performs. For this write setup operation, an address of 0x40 is hardware generated. The bank and other address lines are driven with the address to be programmed. The next command is Active which registers the row address and confirms the bank address. The third command supplies the column address, re-confirms the bank address, and supplies the data to be written. SyncFlash does not support burst writes, therefore a Burst Terminate command is not required.

A read to the memory region initiates the status read sequence. The first command issued to the SyncFlash is the Load Command Register with A [7:0] set to 0x70 which corresponds to the Read Status Register operation. The bank and other address lines are driven to the selected address. The second command is Active which sets up the status register read. The bank and row addresses are driven during this command. The third command of the triplet is Read. Bank and column addresses are driven on the address bus during this command. Data is returned from memory on the low order 8 data bits following the CAS latency.

Specifications

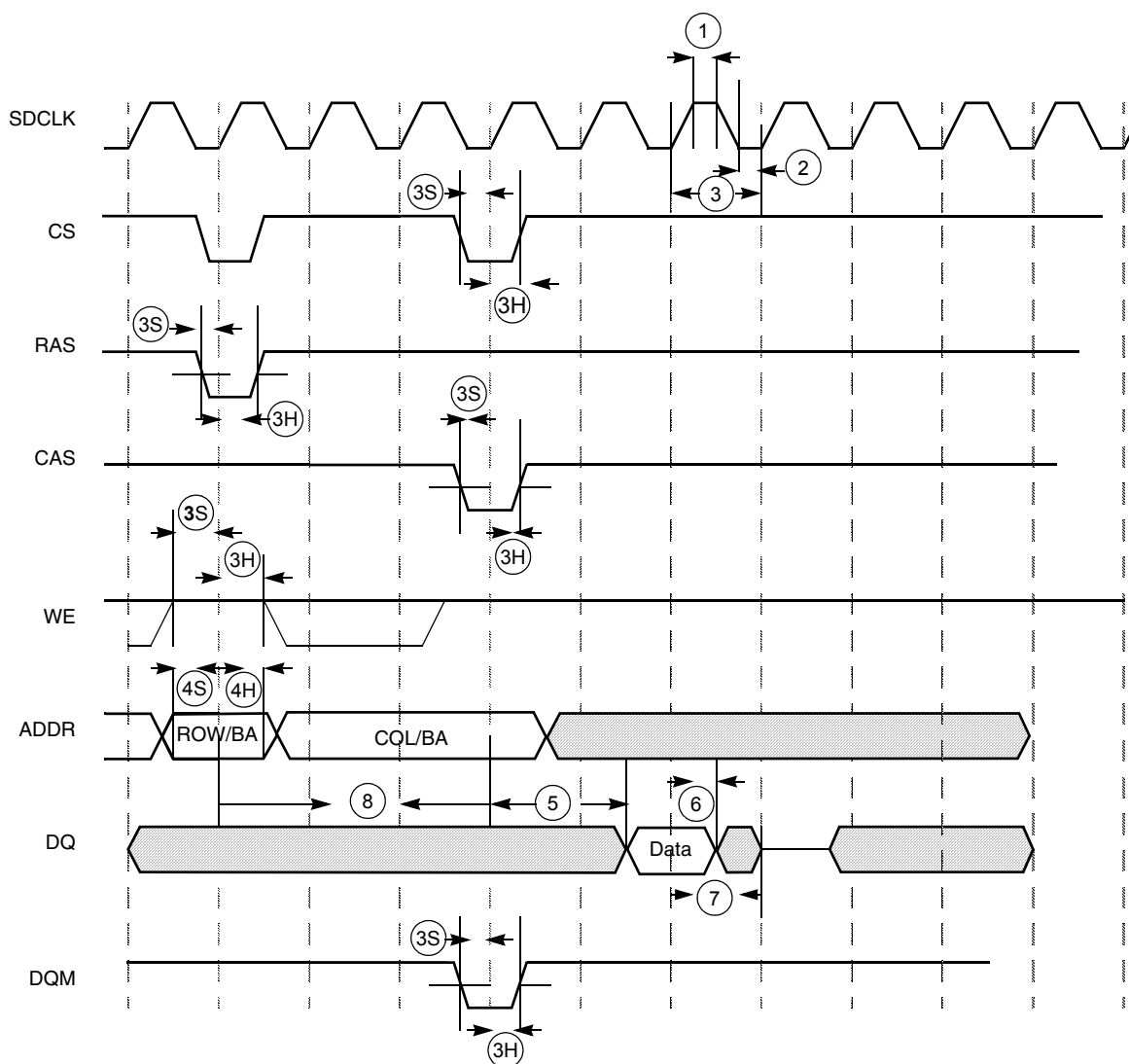

Note: CKE is high during the read/write cycle.

Figure 57. SDRAM/SyncFlash Read Cycle Timing Diagram

Table 34. SDRAM Timing Parameter Table

Ref No.	Parameter	1.8V		3.3V		Unit
		Minimum	Maximum	Minimum	Maximum	
1	SDRAM clock high-level width	2.67	–	4	–	ns
2	SDRAM clock low-level width	6	–	4	–	ns
3	SDRAM clock cycle time	10.4	–	10	–	ns
3S	CS, RAS, CAS, WE, DQM setup time	3.42	–	3	–	ns
3H	CS, RAS, CAS, WE, DQM hold time	2.28	–	2	–	ns
4S	Address setup time	3.42	–	3	–	ns

Table 34. SDRAM Timing Parameter Table (Continued)

Ref No.	Parameter	1.8V		3.3V		Unit
		Minimum	Maximum	Minimum	Maximum	
4H	Address hold time	2.28	–	2	–	ns
5	SDRAM access time (CL = 3)	–	6.84	–	6	ns
5	SDRAM access time (CL = 2)	–	6.84	–	6	ns
5	SDRAM access time (CL = 1)	–	22	–	22	ns
6	Data out hold time	2.85	–	2.5	–	ns
7	Data out high-impedance time (CL = 3)	–	6.84	–	6	ns
7	Data out high-impedance time (CL = 2)	–	6.84	–	6	ns
7	Data out high-impedance time (CL = 1)	–	22	–	22	ns
8	Active to read/write command period (RC = 1)	t_{RCD}^1	–	t_{RCD}^1	–	ns

1. t_{RCD} = SDRAM clock cycle time. The t_{RCD} setting can be found in the MC9328MX1 reference manual.

Specifications

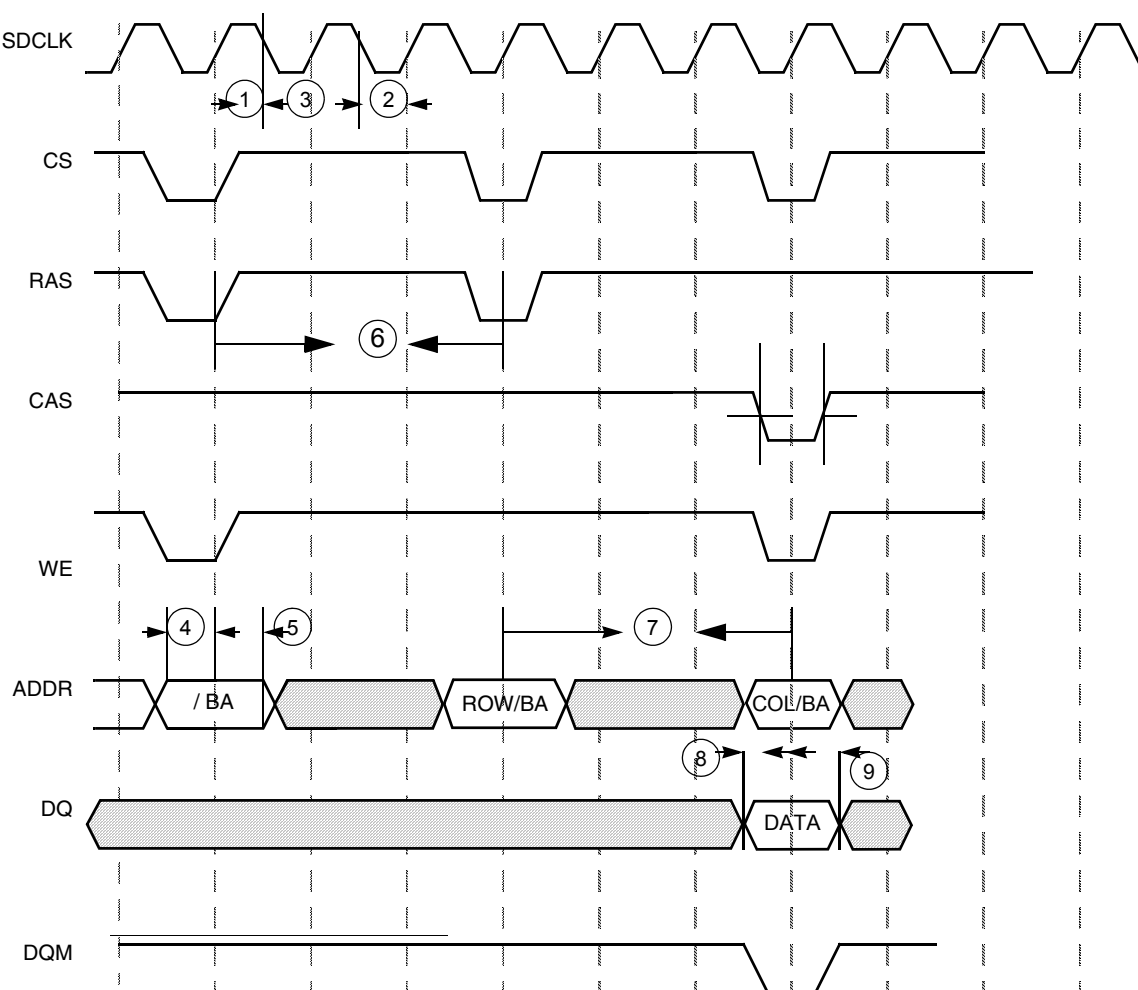

Figure 58. SDRAM/SyncFlash Write Cycle Timing Diagram

Table 35. SDRAM Write Timing Parameter Table

Ref No.	Parameter	1.8V		3.3V		Unit
		Minimum	Maximum	Minimum	Maximum	
1	SDRAM clock high-level width	2.67	–	4	–	ns
2	SDRAM clock low-level width	6	–	4	–	ns
3	SDRAM clock cycle time	10.4	–	10	–	ns
4	Address setup time	3.42	–	3	–	ns
5	Address hold time	2.28	–	2	–	ns
6	Precharge cycle period ¹	t_{RP}^2	–	t_{RP}^2	–	ns
7	Active to read/write command delay	t_{RCD}^2	–	t_{RCD}^2	–	ns
8	Data setup time	4.0	–	2	–	ns

Table 35. SDRAM Write Timing Parameter Table (Continued)

Ref No.	Parameter	1.8V		3.3V		Unit
		Minimum	Maximum	Minimum	Maximum	
9	Data hold time	2.28	–	2	–	ns

1. Precharge cycle timing is included in the write timing diagram.
2. t_{RP} and t_{RCD} = SDRAM clock cycle time. These settings can be found in the MC9328MX1 reference manual.

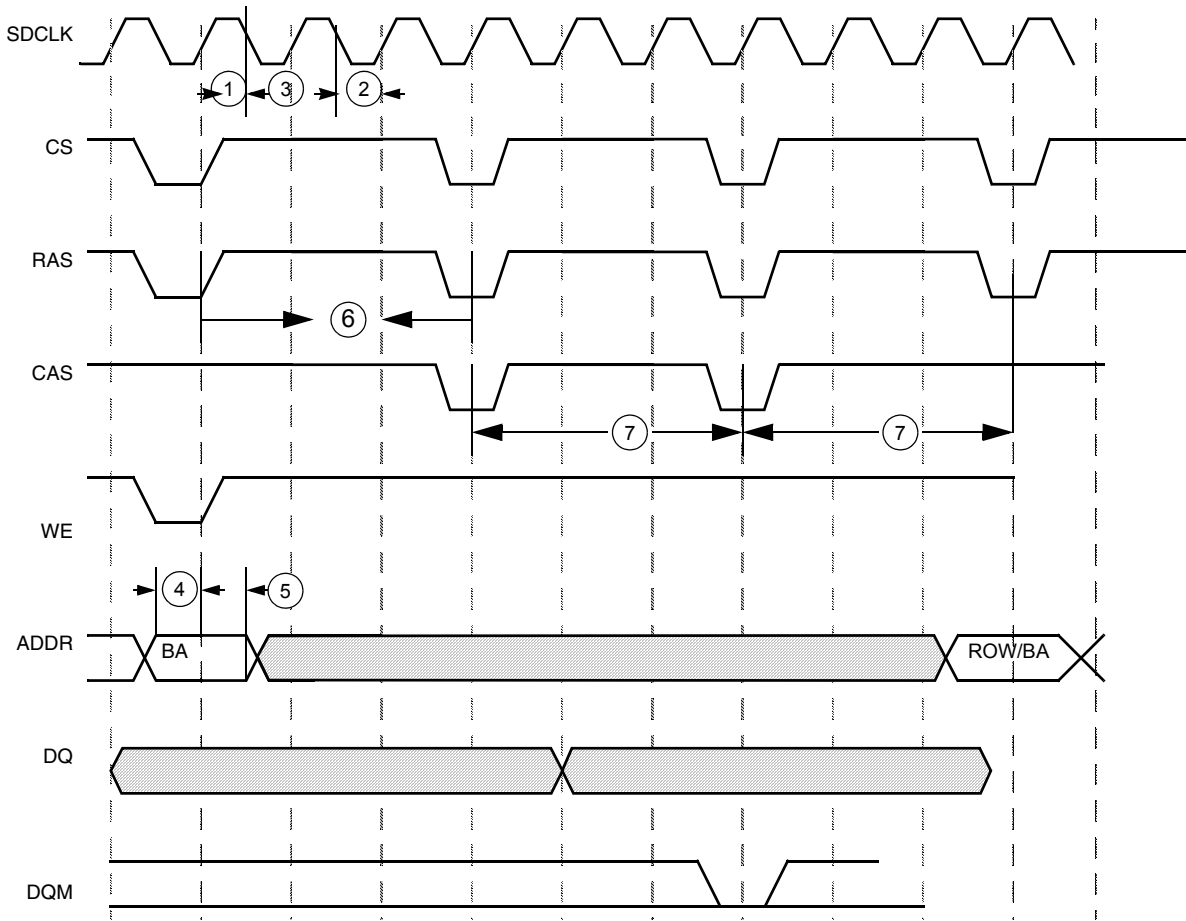

Figure 59. SDRAM Refresh Timing Diagram

Table 36. SDRAM Refresh Timing Parameter Table

Ref No.	Parameter	1.8V		3.3V		Unit
		Minimum	Maximum	Minimum	Maximum	
1	SDRAM clock high-level width	2.67	–	4	–	ns
2	SDRAM clock low-level width	6	–	4	–	ns
3	SDRAM clock cycle time	10.4	–	10	–	ns

Table 36. SDRAM Refresh Timing Parameter Table (Continued)

Ref No.	Parameter	1.8V		3.3V		Unit
		Minimum	Maximum	Minimum	Maximum	
4	Address setup time	3.42	–	3	–	ns
5	Address hold time	2.28	–	2	–	ns
6	Precharge cycle period	t_{RP}^1	–	t_{RP}^1	–	ns
7	Auto precharge command period	t_{RC}^1	–	t_{RC}^1	–	ns

1. t_{RP} and t_{RC} = SDRAM clock cycle time. These settings can be found in the MC9328MX1 reference manual.

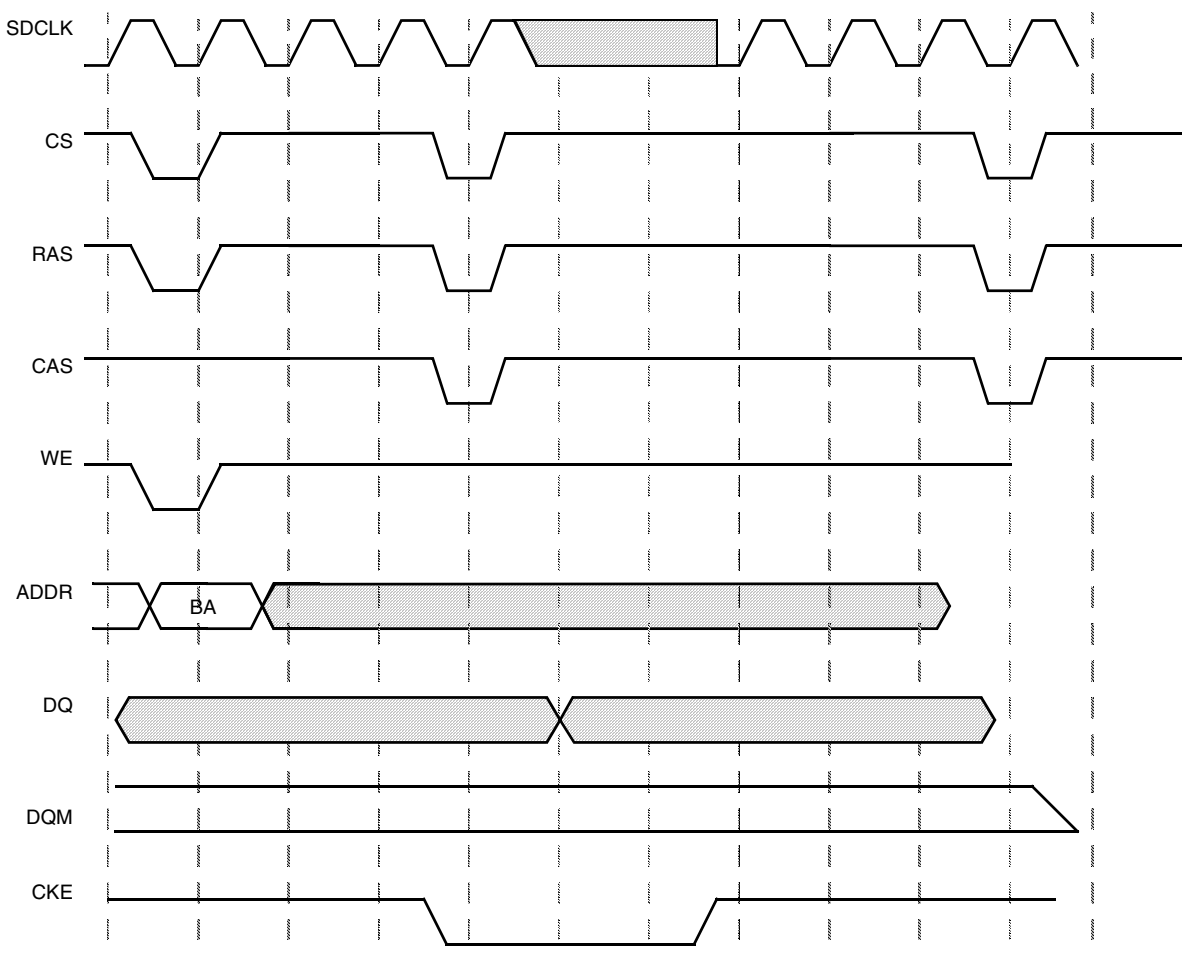

Figure 60. SDRAM Self-Refresh Cycle Timing Diagram

3.18 USB Device Port

Four types of data transfer modes exist for the USB module: control transfers, bulk transfers, isochronous transfers, and interrupt transfers. From the perspective of the USB module, the interrupt transfer type is identical to the bulk data transfer mode, and no additional hardware is supplied to support it. This section covers the transfer modes and how they work from the ground up.

Data moves across the USB in packets. Groups of packets are combined to form data transfers. The same packet transfer mechanism applies to bulk, interrupt, and control transfers. Isochronous data is also moved in the form of packets, however, because isochronous pipes are given a fixed portion of the USB bandwidth at all times, there is no end-of-transfer.

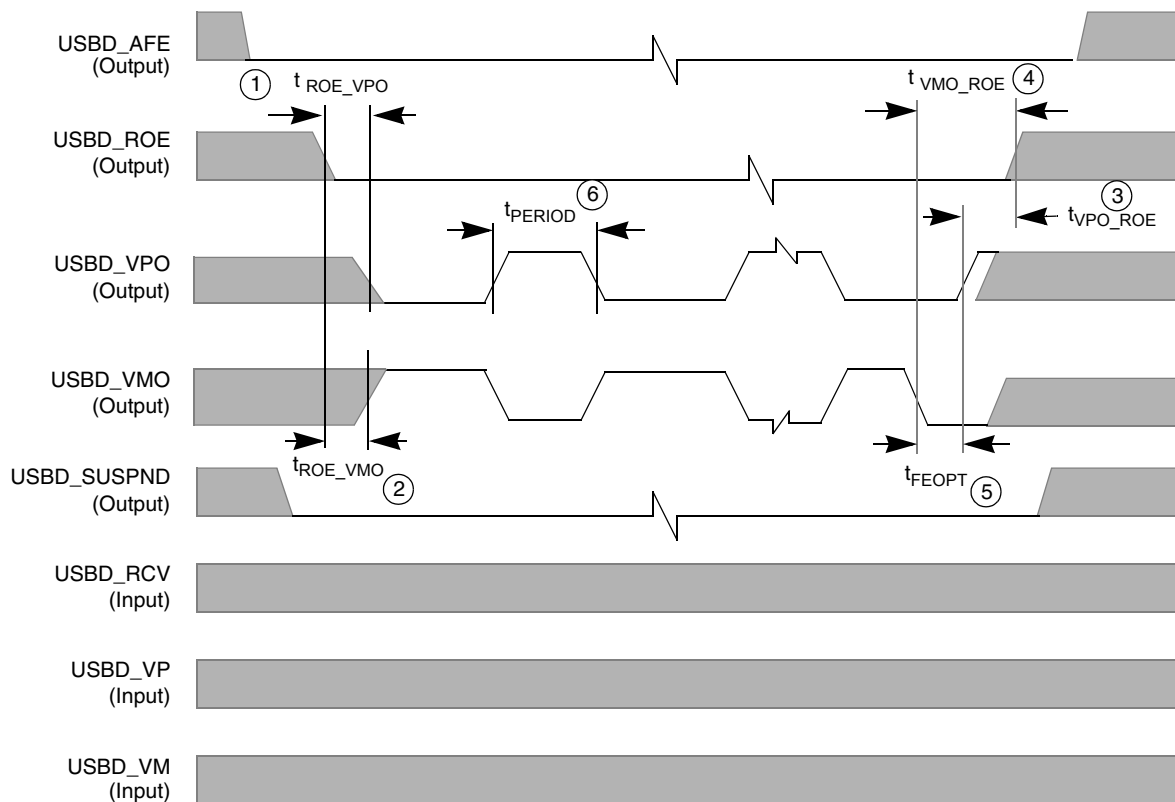

Figure 61. USB Device Timing Diagram for Data Transfer to USB Transceiver (TX)

Table 37. USB Device Timing Parameter Table for Data Transfer to USB Transceiver (TX)

Ref No.	Parameter	Minimum	Maximum	Unit
1	t_{ROE_VPO} ; USBD_ROE active to USBD_VPO low	83.14	83.47	ns
2	t_{ROE_VMO} ; USBD_ROE active to USBD_VMO high	81.55	81.98	ns
3	t_{VPO_ROE} ; USBD_VPO high to USBD_ROE deactivated	83.54	83.80	ns
4	t_{VMO_ROE} ; USBD_VMO low to USBD_ROE deactivated (includes SE0)	248.90	249.13	ns
5	t_{FEOPT} ; SE0 interval of EOP	160.00	175.00	ns
6	t_{PERIOD} ; Data transfer rate	11.97	12.03	Mb/s

Specifications

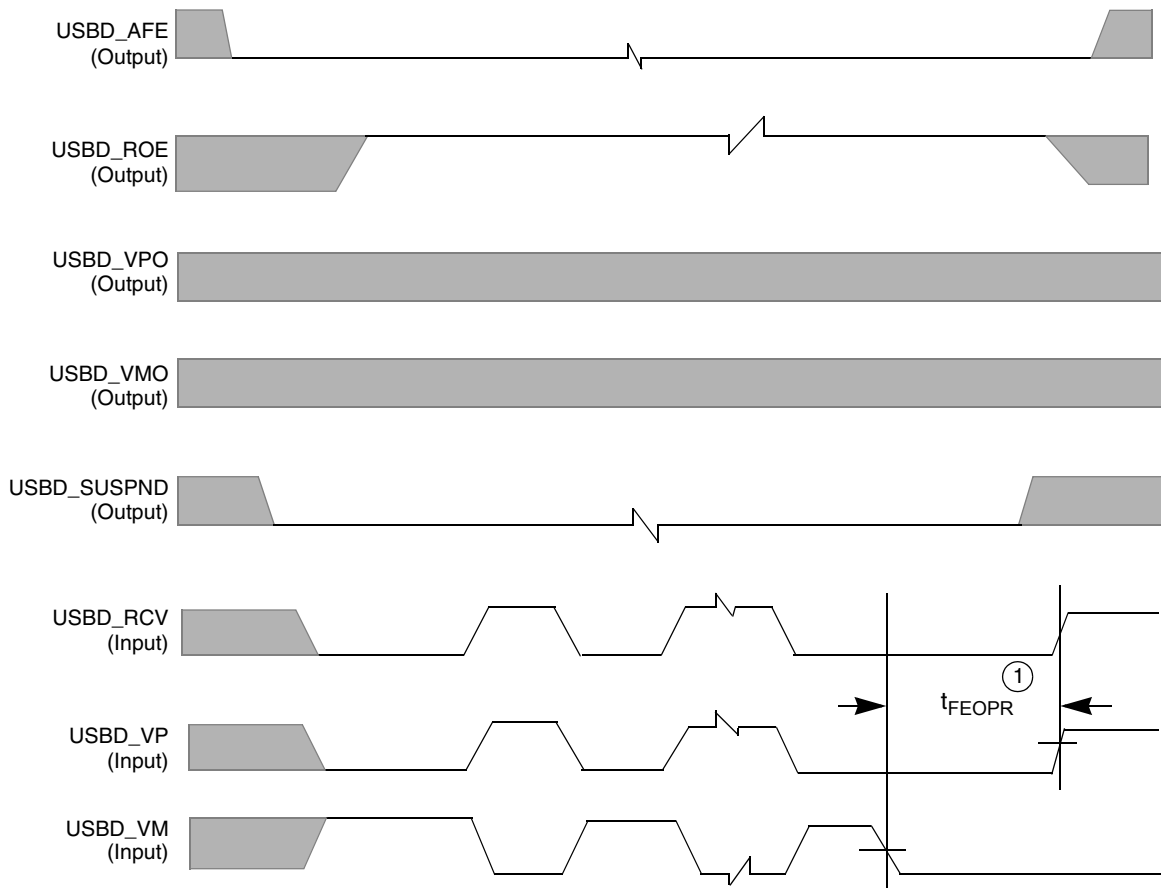

Figure 62. USB Device Timing Diagram for Data Transfer from USB Transceiver (RX)

Table 38. USB Device Timing Parameter Table for Data Transfer from USB Transceiver (RX)

Ref No.	Parameter	Minimum	Maximum	Unit
1	t_{FEOPR} ; Receiver SE0 interval of EOP	82	–	ns

3.19 I²C Module

The I²C communication protocol consists of seven elements: START, Data Source/Recipient, Data Direction, Slave Acknowledge, Data, Data Acknowledge, and STOP.

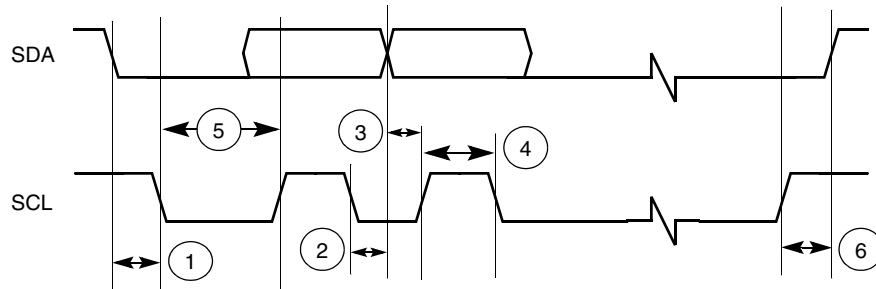

Figure 63. Definition of Bus Timing for I²C

Table 39. I²C Bus Timing Parameter Table

Ref No.	Parameter	1.8V +/- 0.10V		3.0V +/- 0.30V		Unit
		Minimum	Maximum	Minimum	Maximum	
1	Hold time (repeated) START condition	182	–	160	–	ns
2	Data hold time	0	171	0	150	ns
3	Data setup time	11.4	–	10	–	ns
4	HIGH period of the SCL clock	80	–	120	–	ns
5	LOW period of the SCL clock	480	–	320	–	ns
6	Setup time for STOP condition	182.4	–	160	–	ns

3.20 Synchronous Serial Interface

The MC9328MX1 processor contains two identical SSI modules. The transmit and receive sections of the SSI can be synchronous or asynchronous. In synchronous mode, the transmitter and the receiver use a common clock and frame synchronization signal. In asynchronous mode, the transmitter and receiver each have their own clock and frame synchronization signals. Continuous or gated clock mode can be selected. In continuous mode, the clock runs continuously. In gated clock mode, the clock functions only during transmission. The internal and external clock timing diagrams are shown in Figure 65 through Figure 67 on page 81.

Normal or network mode can also be selected. In normal mode, the SSI functions with one data word of I/O per frame. In network mode, a frame can contain between 2 and 32 data words. Network mode is typically used in star or ring-time division multiplex networks with other processors or codecs, allowing interface to time division multiplexed networks without additional logic. Use of the gated clock is not allowed in network mode. These distinctions result in the basic operating modes that allow the SSI to communicate with a wide variety of devices.

Specifications

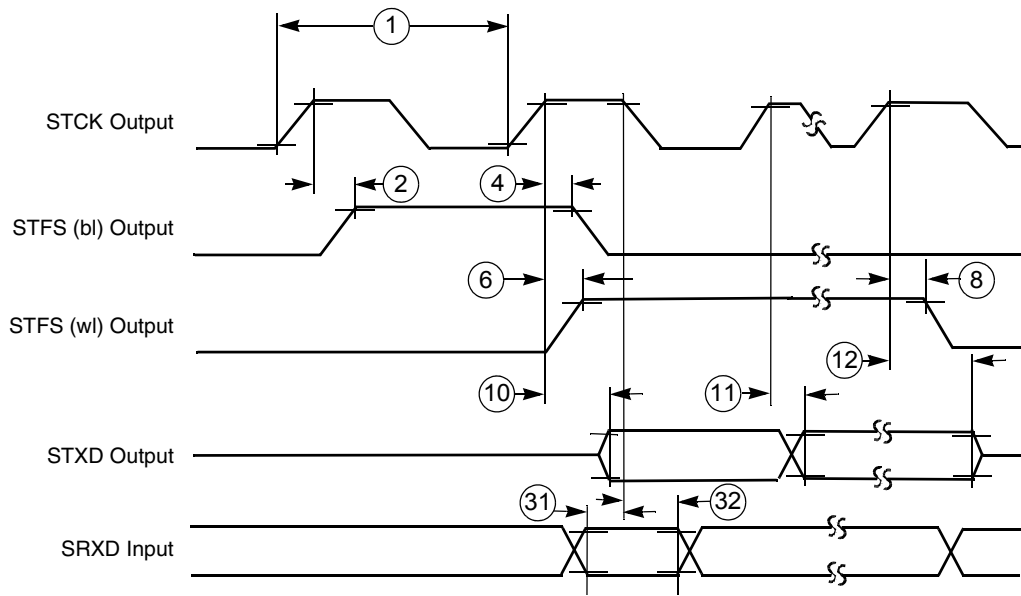

Note: SRXD input in synchronous mode only.

Figure 64. SSI Transmitter Internal Clock Timing Diagram

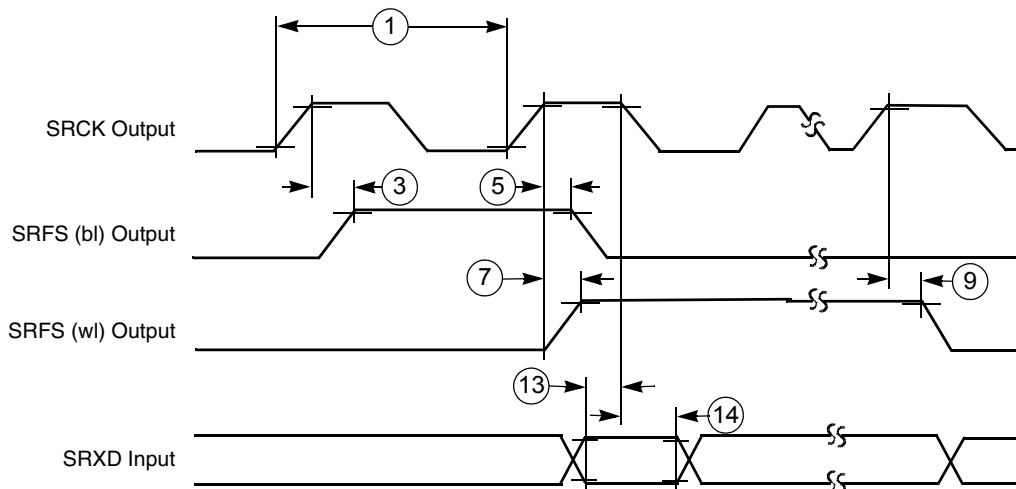
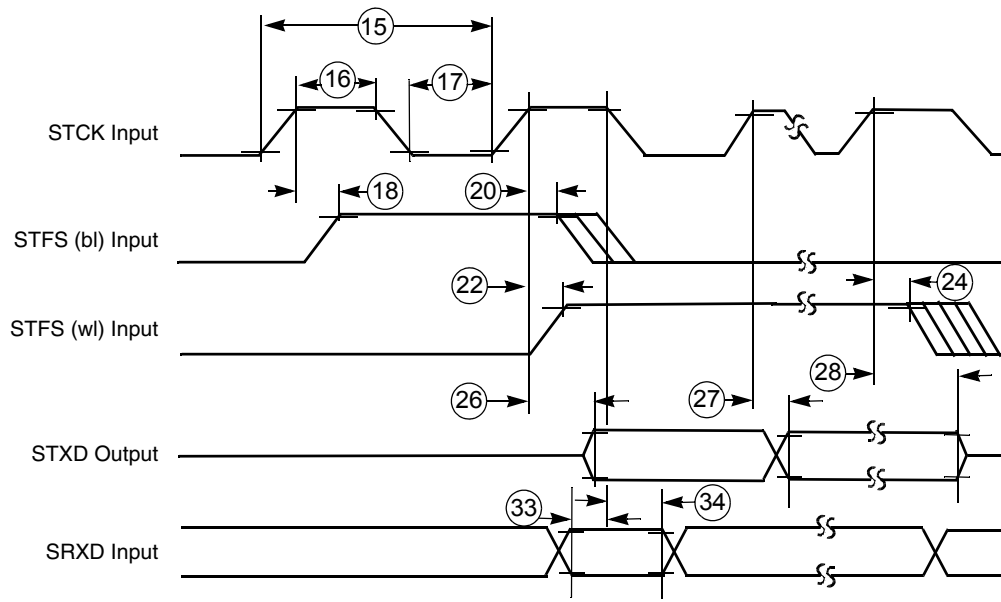

Figure 65. SSI Receiver Internal Clock Timing Diagram



Note: SRXD Input in Synchronous mode only.

Figure 66. SSI Transmitter External Clock Timing Diagram

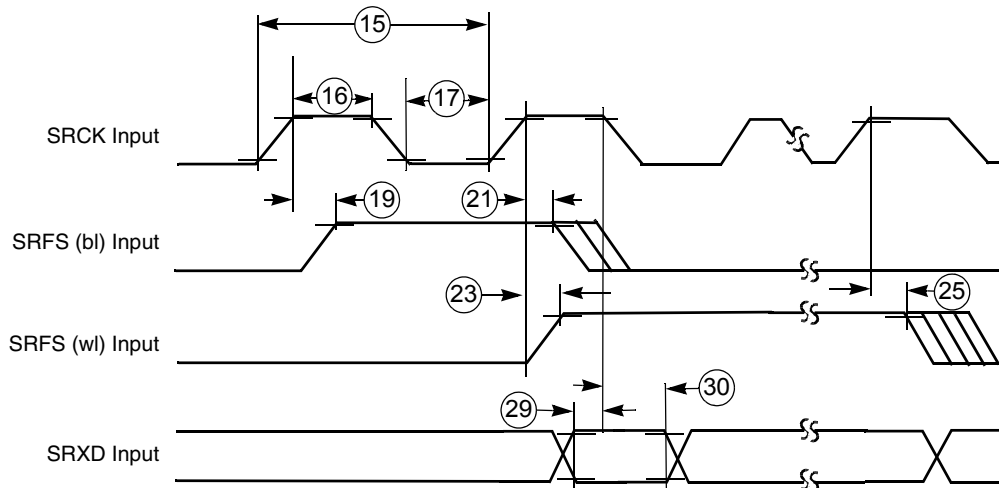

Figure 67. SSI Receiver External Clock Timing Diagram

Table 40. SSI 1 Timing Parameter Table

Ref No.	Parameter	1.8V +/- 0.10V		3.0V +/- 0.30V		Unit
		Minimum	Maximum	Minimum	Maximum	
Internal Clock Operation¹ (Port C Primary Function)²						
1	STCK/SRCK clock period ¹	95	–	83.3	–	ns
2	STCK high to STFS (bl) high ³	1.5	4.5	1.3	3.9	ns
3	SRCK high to SRFS (bl) high ³	-1.2	-1.7	-1.1	-1.5	ns

Table 40. SSI 1 Timing Parameter Table (Continued)

Ref No.	Parameter	1.8V +/- 0.10V		3.0V +/- 0.30V		Unit
		Minimum	Maximum	Minimum	Maximum	
4	STCK high to STFS (bl) low ³	2.5	4.3	2.2	3.8	ns
5	SRCK high to SRFS (bl) low ³	0.1	-0.8	0.1	-0.8	ns
6	STCK high to STFS (wl) high ³	1.48	4.45	1.3	3.9	ns
7	SRCK high to SRFS (wl) high ³	-1.1	-1.5	-1.1	-1.5	ns
8	STCK high to STFS (wl) low ³	2.51	4.33	2.2	3.8	ns
9	SRCK high to SRFS (wl) low ³	0.1	-0.8	0.1	-0.8	ns
10	STCK high to STXD valid from high impedance	14.25	15.73	12.5	13.8	ns
11a	STCK high to STXD high	0.91	3.08	0.8	2.7	ns
11b	STCK high to STXD low	0.57	3.19	0.5	2.8	ns
12	STCK high to STXD high impedance	12.88	13.57	11.3	11.9	ns
13	SRXD setup time before SRCK low	21.1	–	18.5	–	ns
14	SRXD hold time after SRCK low	0	–	0	–	ns
External Clock Operation (Port C Primary Function)²						
15	STCK/SRCK clock period ¹	92.8	–	81.4	–	ns
16	STCK/SRCK clock high period	27.1	–	40.7	–	ns
17	STCK/SRCK clock low period	61.1	–	40.7	–	ns
18	STCK high to STFS (bl) high ³	–	92.8	0	81.4	ns
19	SRCK high to SRFS (bl) high ³	–	92.8	0	81.4	ns
20	STCK high to STFS (bl) low ³	–	92.8	0	81.4	ns
21	SRCK high to SRFS (bl) low ³	–	92.8	0	81.4	ns
22	STCK high to STFS (wl) high ³	–	92.8	0	81.4	ns
23	SRCK high to SRFS (wl) high ³	–	92.8	0	81.4	ns
24	STCK high to STFS (wl) low ³	–	92.8	0	81.4	ns
25	SRCK high to SRFS (wl) low ³	–	92.8	0	81.4	ns
26	STCK high to STXD valid from high impedance	18.01	28.16	15.8	24.7	ns
27a	STCK high to STXD high	8.98	18.13	7.0	15.9	ns
27b	STCK high to STXD low	9.12	18.24	8.0	16.0	ns

Table 40. SSI 1 Timing Parameter Table (Continued)

Ref No.	Parameter	1.8V +/- 0.10V		3.0V +/- 0.30V		Unit
		Minimum	Maximum	Minimum	Maximum	
28	STCK high to STXD high impedance	18.47	28.5	16.2	25.0	ns
29	SRXD setup time before SRCK low	1.14	–	1.0	–	ns
30	SRXD hold time after SRCK low	0	–	0	–	ns
Synchronous Internal Clock Operation (Port C Primary Function)²						
31	SRXD setup before STCK falling	15.4	–	13.5	–	ns
32	SRXD hold after STCK falling	0	–	0	–	ns
Synchronous External Clock Operation (Port C Primary Function)²						
33	SRXD setup before STCK falling	1.14	–	1.0	–	ns
34	SRXD hold after STCK falling	0	–	0	–	ns

1. All the timings for the SSI are given for a non-inverted serial clock polarity (TSCKP/RSCKP = 0) and a non-inverted frame sync (TFSI/RFSI = 0). If the polarity of the clock and/or the frame sync have been inverted, all the timing remains valid by inverting the clock signal STCK/SRCK and/or the frame sync STFS/SRFS shown in the tables and in the figures.
2. There are 2 sets of I/O signals for the SSI module. They are from Port C primary function (PC3 – PC8) and Port B alternate function (PB14 – PB19). When SSI signals are configured as outputs, they can be viewed both at Port C primary function and Port B alternate function. When SSI signals are configured as input, the SSI module selects the input based on status of the FMCR register bits in the Clock controller module (CRM). By default, the input are selected from Port C primary function.
3. bl = bit length; wl = word length.

Table 41. SSI 2 Timing Parameter Table

Ref No.	Parameter	1.8V +/- 0.10V		3.0V +/- 0.30V		Unit
		Minimum	Maximum	Minimum	Maximum	
Internal Clock Operation¹ (Port B Alternate Function)²						
1	STCK/SRCK clock period ¹	95	–	83.3	–	ns
2	STCK high to STFS (bl) high ³	1.7	4.8	1.5	4.2	ns
3	SRCK high to SRFS (bl) high ³	-0.1	1.0	-0.1	1.0	ns
4	STCK high to STFS (bl) low ³	3.08	5.24	2.7	4.6	ns
5	SRCK high to SRFS (bl) low ³	1.25	2.28	1.1	2.0	ns
6	STCK high to STFS (wl) high ³	1.71	4.79	1.5	4.2	ns
7	SRCK high to SRFS (wl) high ³	-0.1	1.0	-0.1	1.0	ns
8	STCK high to STFS (wl) low ³	3.08	5.24	2.7	4.6	ns

Table 41. SSI 2 Timing Parameter Table (Continued)

Ref No.	Parameter	1.8V +/- 0.10V		3.0V +/- 0.30V		Unit
		Minimum	Maximum	Minimum	Maximum	
9	SRCK high to SRFS (wl) low ³	1.25	2.28	1.1	2.0	ns
10	STCK high to STXD valid from high impedance	14.93	16.19	13.1	14.2	ns
11a	STCK high to STXD high	1.25	3.42	1.1	3.0	ns
11b	STCK high to STXD low	2.51	3.99	2.2	3.5	ns
12	STCK high to STXD high impedance	12.43	14.59	10.9	12.8	ns
13	SRXD setup time before SRCK low	20	–	17.5	–	ns
14	SRXD hold time after SRCK low	0	–	0	–	ns
External Clock Operation (Port B Alternate Function)²						
15	STCK/SRCK clock period ¹	92.8	–	81.4	–	ns
16	STCK/SRCK clock high period	27.1	–	40.7	–	ns
17	STCK/SRCK clock low period	61.1	–	40.7	–	ns
18	STCK high to STFS (bl) high ³	–	92.8	0	81.4	ns
19	SRCK high to SRFS (bl) high ³	–	92.8	0	81.4	ns
20	STCK high to STFS (bl) low ³	–	92.8	0	81.4	ns
21	SRCK high to SRFS (bl) low ³	–	92.8	0	81.4	ns
22	STCK high to STFS (wl) high ³	–	92.8	0	81.4	ns
23	SRCK high to SRFS (wl) high ³	–	92.8	0	81.4	ns
24	STCK high to STFS (wl) low ³	–	92.8	0	81.4	ns
25	SRCK high to SRFS (wl) low ³	–	92.8	0	81.4	ns
26	STCK high to STXD valid from high impedance	18.9	29.07	16.6	25.5	ns
27a	STCK high to STXD high	9.23	20.75	8.1	18.2	ns
27b	STCK high to STXD low	10.60	21.32	9.3	18.7	ns
28	STCK high to STXD high impedance	17.90	29.75	15.7	26.1	ns
29	SRXD setup time before SRCK low	1.14	–	1.0	–	ns
30	SRXD hole time after SRCK low	0	–	0	–	ns

Table 41. SSI 2 Timing Parameter Table (Continued)

Ref No.	Parameter	NOTES 1.8V +/- 0.10V		3.0V +/- 0.30V		Unit
		Minimum	Maximum	Minimum	Maximum	
Synchronous Internal Clock Operation (Port B Alternate Function)²						
31	SRXD setup before STCK falling	18.81	–	16.5	–	ns
32	SRXD hold after STCK falling	0	–	0	–	ns
Synchronous External Clock Operation (Port B Alternate Function)²						
33	SRXD setup before STCK falling	1.14	–	1.0	–	ns
34	SRXD hold after STCK falling	0	–	0	–	ns

1. All the timings for both SSI modules are given for a non-inverted serial clock polarity (TSCKP/RSCCKP = 0) and a non-inverted frame sync (TFSI/RFSI = 0). If the polarity of the clock and/or the frame sync have been inverted, all the timing remains valid by inverting the clock signal STCK/SRCK and/or the frame sync STFS/SRFS shown in the tables and in the figures.
2. There is one set of I/O signals for the SSI2 module. They are from Port C alternate function (PC19 – PC24). When SSI signals are configured as outputs, they can be viewed at Port C alternate function a. When SSI signals are configured as inputs, the SSI module selects the input based on FMCR register bits in the Clock controller module (CRM). By default, the input is selected from Port C alternate function.
3. bl = bit length; wl = word length

3.21 CMOS Sensor Interface

The CSI module consists of a control register to configure the interface timing, a control register for statistic data generation, a status register, interface logic, a 32×32 image data receive FIFO, and a 16×32 statistic data FIFO.

3.21.1 Gated Clock Mode

Figure 68 shows the timing diagram when the CMOS sensor output data is configured for negative edge and the CSI is programmed to received data on the positive edge. Figure 69 on page 87 shows the timing diagram when the CMOS sensor output data is configured for positive edge and the CSI is programmed to received data in negative edge. The parameters for the timing diagrams are listed in Table 42 on page 87.

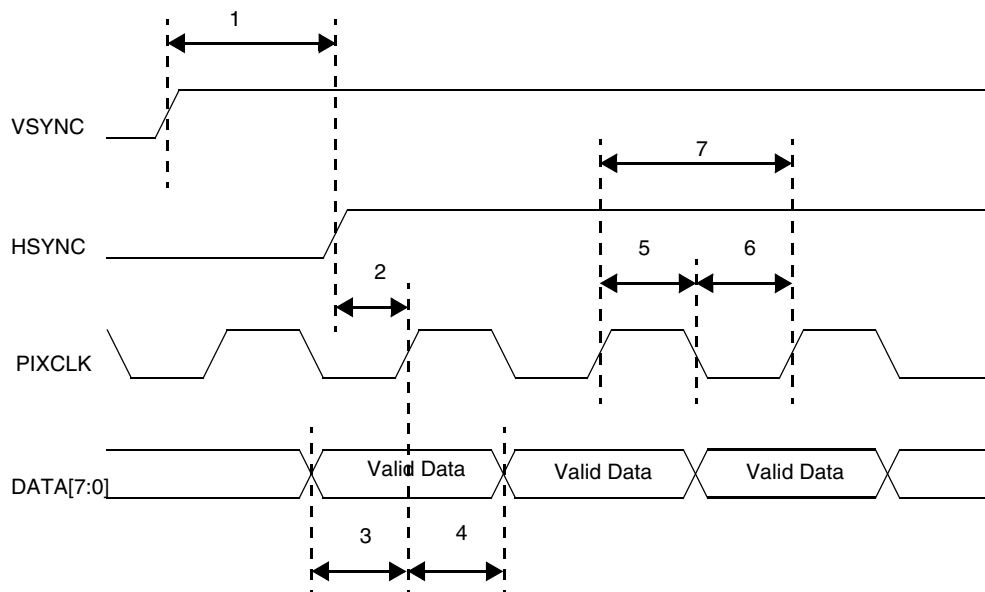

**Figure 68. Sensor Output Data on Pixel Clock Falling Edge
CSI Latches Data on Pixel Clock Rising Edge**

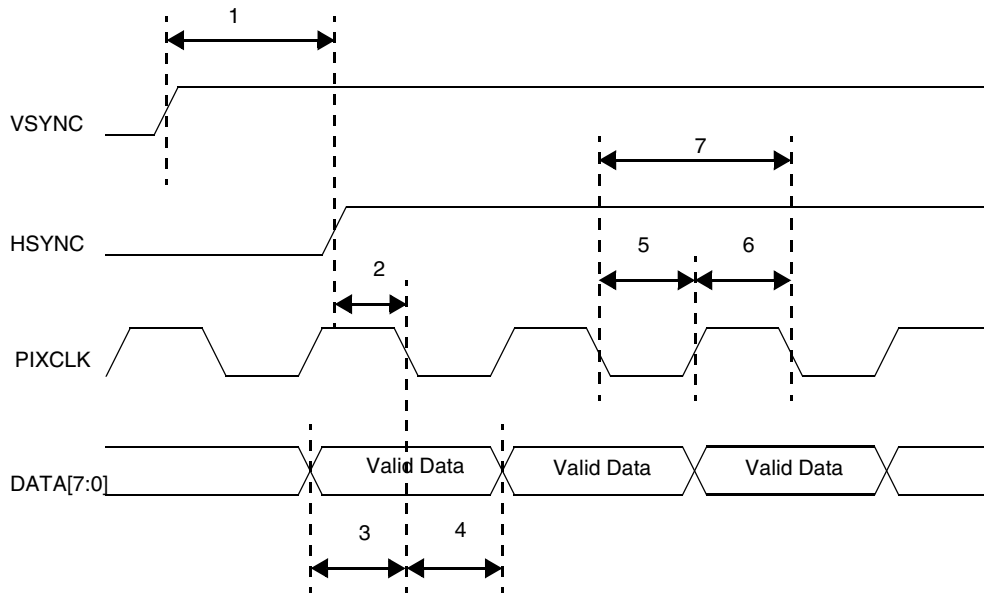

**Figure 69. Sensor Output Data on Pixel Clock Rising Edge
CSI Latches Data on Pixel Clock Falling Edge**

Table 42. Gated Clock Mode Timing Parameters

Ref No.	Parameter	Minimum	Maximum	Unit
1	csi_vsync to csi_hsync	$9 * T_{HCLK}$	–	ns
2	csi_hsync to csi_pixclk	3	$(T_p / 2) - 3$	ns
3	csi_d setup time	1	–	ns
4	csi_d hold time	1	–	ns
5	csi_pixclk high time	10.42	–	ns
6	csi_pixclk low time	10.42	–	ns
7	csi_pixclk frequency	0	48	MHz

The limitation on pixel clock rise time / fall time are not specified. It should be calculated from the hold time and setup time, according to:

Rising-edge latch data

max rise time allowed = (positive duty cycle - hold time)
max fall time allowed = (negative duty cycle - setup time)

In most of case, duty cycle is 50 / 50, therefore

max rise time = (period / 2 - hold time)
max fall time = (period / 2 - setup time)

For example: Given pixel clock period = 10ns, duty cycle = 50 / 50, hold time = 1ns, setup time = 1ns.

positive duty cycle = $10 / 2 = 5\text{ns}$
=> max rise time allowed = $5 - 1 = 4\text{ns}$

Specifications

negative duty cycle = $10 / 2 = 5\text{ns}$
=> max fall time allowed = $5 - 1 = 4\text{ns}$

Falling-edge latch data

max fall time allowed = (negative duty cycle - hold time)
max rise time allowed = (positive duty cycle - setup time)

3.21.2 Non-Gated Clock Mode

Figure 70 shows the timing diagram when the CMOS sensor output data is configured for negative edge and the CSI is programmed to received data on the positive edge. Figure 71 on page 89 shows the timing diagram when the CMOS sensor output data is configured for positive edge and the CSI is programmed to received data in negative edge. The parameters for the timing diagrams are listed in Table 43 on page 89.

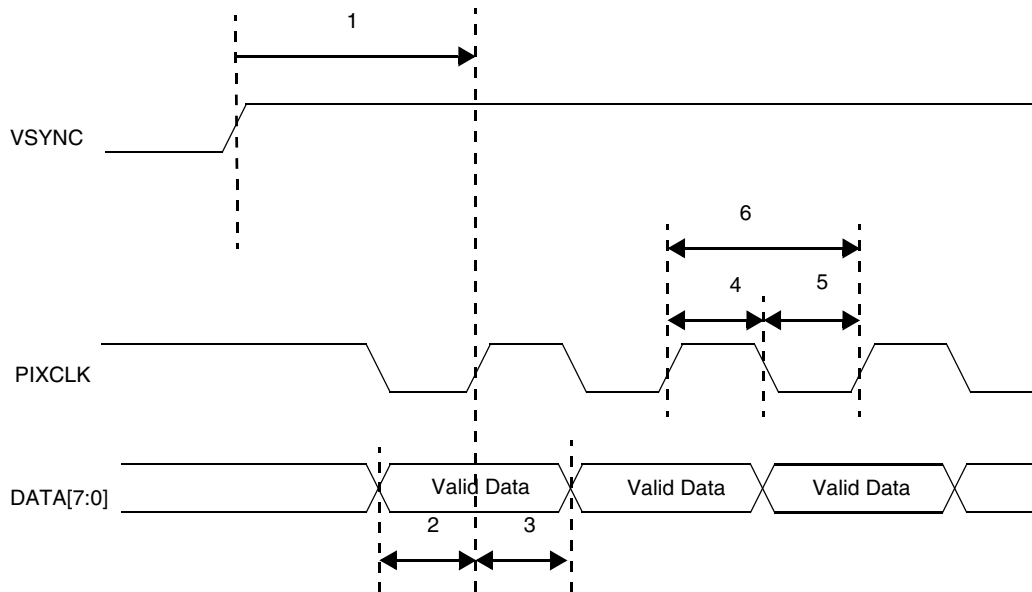

**Figure 70. Sensor Output Data on Pixel Clock Falling Edge
CSI Latches Data on Pixel Clock Rising Edge**

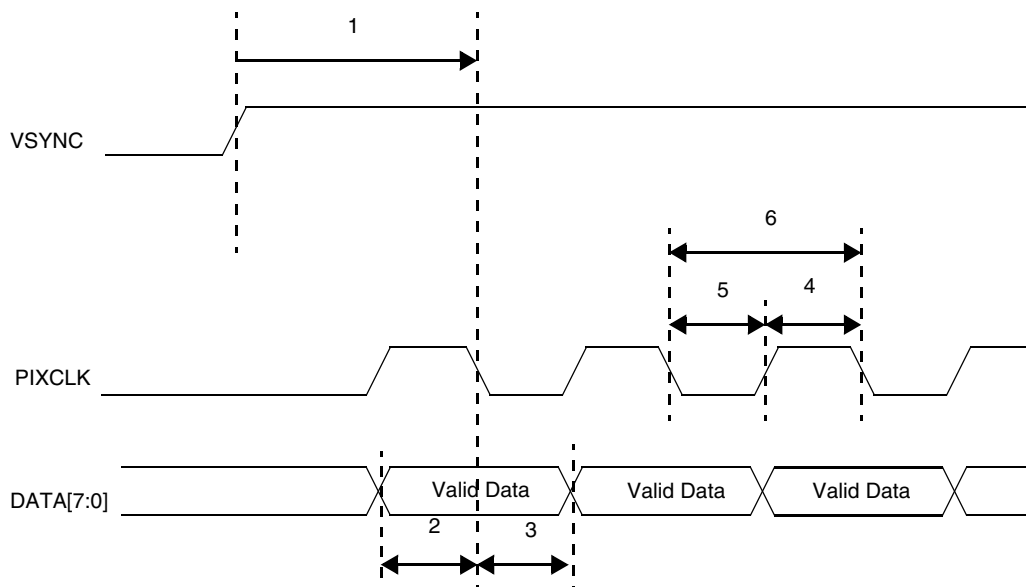

**Figure 71. Sensor Output Data on Pixel Clock Rising Edge
CSI Latches Data on Pixel Clock Falling Edge**

Table 43. Non-Gated Clock Mode Parameters

Ref No.	Parameter	Minimum	Maximum	Unit
1	csi_vsync to csi_pixclk	$9 * T_{HCLK}$	–	ns
2	csi_d setup time	1	–	ns
3	csi_d hold time	1	–	ns
4	csi_pixclk high time	10.42	–	ns
5	csi_pixclk low time	10.42	–	ns
6	csi_pixclk frequency	0	48	MHz

The limitation on pixel clock rise time / fall time are not specified. It should be calculated from the hold time and setup time, according to:

$$\begin{aligned} \text{max rise time allowed} &= (\text{positive duty cycle} - \text{hold time}) \\ \text{max fall time allowed} &= (\text{negative duty cycle} - \text{setup time}) \end{aligned}$$

In most of case, duty cycle is 50 / 50, therefore:

$$\begin{aligned} \text{max rise time} &= (\text{period} / 2 - \text{hold time}) \\ \text{max fall time} &= (\text{period} / 2 - \text{setup time}) \end{aligned}$$

For example: Given pixel clock period = 10ns, duty cycle = 50 / 50, hold time = 1ns, setup time = 1ns.

$$\begin{aligned} \text{positive duty cycle} &= 10 / 2 = 5\text{ns} \\ \Rightarrow \text{max rise time allowed} &= 5 - 1 = 4\text{ns} \end{aligned}$$

$$\begin{aligned} \text{negative duty cycle} &= 10 / 2 = 5\text{ns} \\ \Rightarrow \text{max fall time allowed} &= 5 - 1 = 4\text{ns} \end{aligned}$$

Specifications

Falling-edge latch data

max fall time allowed = (negative duty cycle - hold time)

max rise time allowed = (positive duty cycle - setup time)

4 Pin-Out and Package Information

Table 44. MC9328MX1 BGA Pin Assignments

	1	2	3	4	5	6	7	8	9	10	11	12	13	14	15	16
A	VS S	SD_D AT3	SD_C LK	VSS	USB_D_ AFE	NVDD 4	VSS	UART 1_RT S	UART 1_RX D	NVDD 3	BT5	BT3	QVDD 4	RVP	UIP	NC
B	A2 4	SD_D AT1	SD_C MD	SIM_T X	USB_D_ OE	USB_D_ _VP	SSI_R XCLK	SSI_T XCLK	SPI1_ SCLK	BT11	BT7	BT1	VSS	RVM	UIN	NC
C	A2 3	D31	SD_D AT0	SIM_P D	USB_D_ RCV	UART 2_CT S	UART 2_RX D	SSI_R XFS	UART 1_TX D	BTRF GND	BT8	BTRFV DD	NC	AVDD 2	VSS	R1B
D	A2 2	D30	D29	SIM_S VEN	USB_D_ SUSPN D	USB_D_ _VPO	USB_D_ _VMO	SSI_R XDAT	SPI1_ _SPI_R DY	BT13	BT6	NC	NC	NC	R1A	R2B
E	A2 0	A21	D28	D26	SD_DA T2	USB_D_ _VM	UART 2_RT S	SSI_T XDAT	SPI1_ _SS	BT12	BT4	NC	NC	PY2	PX2	R2A
F	A1 8	D27	D25	A19	A16	SIM_R ST	UART 2_TX D	SSI_T XFS	SPI1_ MISO	BT10	BT2	REV	PY1	PX1	LSCLK	SPL_ SPR
G	A1 5	A17	D24	D23	D21	SIM_R X	SIM_C LK	UART 1_CT S	SPI1_ MOSI	BT9	CLS	CONTR AST	ACD/ OE	LP/ HSYN C	FLM/ VSYNC	LD1
H	A1 3	D22	A14	D20	NVDD1	NVDD 1	VSS	VSS	QVDD 1	PS	LD0	LD2	LD4	LD5	LD9	LD3
J	A1 2	A11	D18	D19	NVDD1	NVDD 1	VSS	NVDD 1	VSS	VSS	LD6	LD7	LD8	LD11	QVDD3	VSS
K	A1 0	D16	A9	D17	NVDD1	VSS	VSS	NVDD 1	NVDD 2	NVDD 2	LD10	LD12	LD13	LD14	TMR2O UT	LD15

Table 44. MC9328MX1 BGA Pin Assignments (Continued)

	1	2	3	4	5	6	7	8	9	10	11	12	13	14	15	16
L	A8	A7	D13	D15	D14	NVDD1	VSS	$\overline{\text{CAS}}$	TCK	TIN	PWM O	CSI_M CLK	CSI_D 0	CSI_D 1	CSI_D2	CSI_D 3
M	A5	D12	D11	A6	SDCLK	VSS	RW	MA10	$\overline{\text{RAS}}$	$\overline{\text{RESET_IN}}$	BIG_E NDIA N	CSI_D4	CSI_H SYNC	CSI_V SYNC	CSI_D6	CSI_D 5
N	A4	$\overline{\text{EB1}}$	D10	D7	A0	D4	PA17	D1	DQM1	$\overline{\text{RESET_SF}}$	$\overline{\text{RESET_OUT}}$	BOOT2	CSI_P IXCLK	CSI_D 7	TMS	TDI
P	A3	D9	EB0	CS3	D6	ECB	D2	D3	DQM3	SDCK E1	BOOT 3	BOOT0	$\overline{\text{TRST}}$	I2C_S CL	I2C_SD A	XTAL 32K
R	EB 2	EB3	A1	$\overline{\text{CS4}}$	D8	D5	$\overline{\text{LBA}}$	$\overline{\text{BCLK}}$	D0	DQM0	SDCK E0	POR	BOOT 1	$\overline{\text{TDO}}$	QVDD2	EXTA L32K
T	VS S	A2	$\overline{\text{OE}}$	$\overline{\text{CS5}}$	CS2	$\overline{\text{CS1}}$	$\overline{\text{CS0}}$	MA11	DQM2	SDWE	CLKO	AVDD1	TRIST ATE	EXTA L16M	XTAL16 M	VSS

4.1 MAPBGA Package Dimensions

Figure 72 illustrates the MAPBGA 14 mm × 14 mm × 1.30 mm package, which has 0.8 mm spacing between the pads. The device designator for the MAPBGA package is VH.

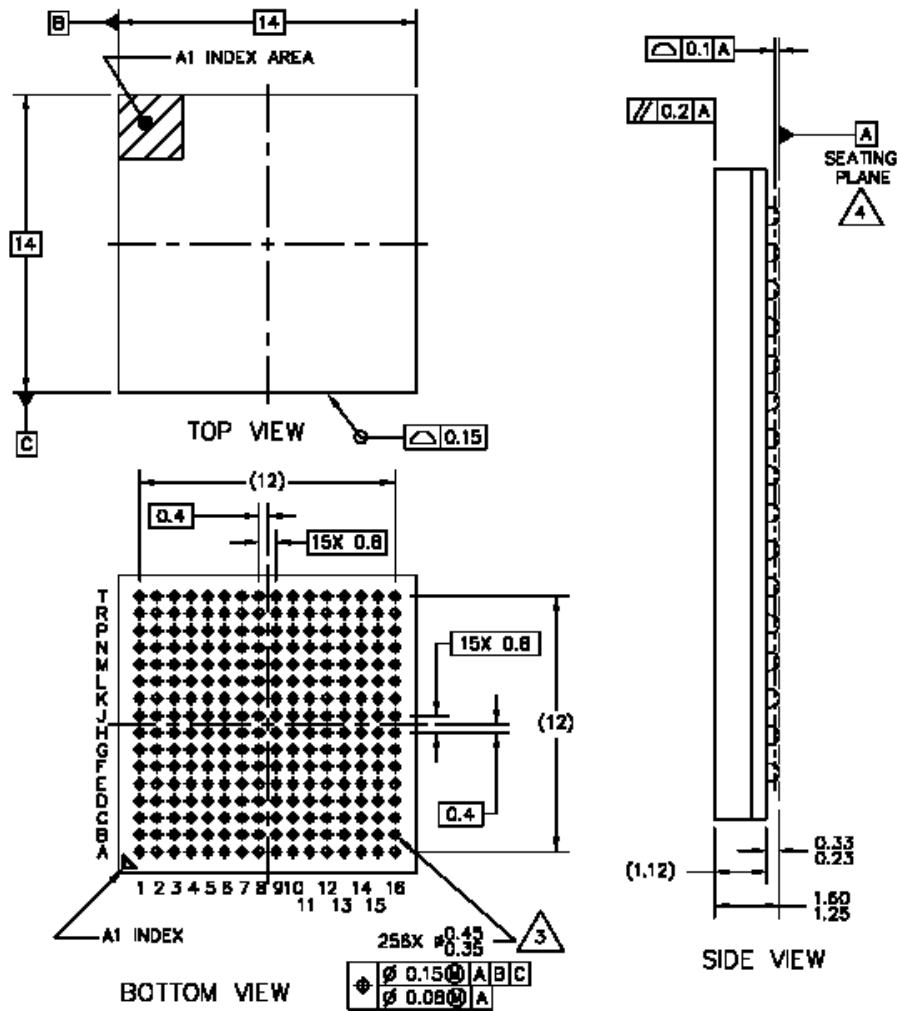

NOTES:

1. ALL DIMENSIONS ARE IN MILLIMETERS.
2. INTERPRET DIMENSIONS AND TOLERANCES PER ASME Y14.5M-1994.
3. MAXIMUM SOLDER BALL DIAMETER MEASURED PARALLEL TO DATUM A.
4. DATUM A, THE SEATING PLANE IS DEFINED BY SPHERICAL CROWNS OF THE SOLDER BALLS.

Figure 72. MC9328MX1 MAPBGA Mechanical Drawing

HOW TO REACH US:**USA/EUROPE/LOCATIONS NOT LISTED:**

Motorola Literature Distribution;
P.O. Box 5405, Denver, Colorado 80217
1-303-675-2140 or 1-800-441-2447

JAPAN:

Motorola Japan Ltd.; SPS, Technical Information Center,
3-20-1, Minami-Azabu Minato-ku, Tokyo 106-8573 Japan
81-3-3440-3569

ASIA/PACIFIC:

Motorola Semiconductors H.K. Ltd.; Silicon Harbour
Centre, 2 Dai King Street, Tai Po Industrial Estate,
Tai Po, N.T., Hong Kong
852-26668334

TECHNICAL INFORMATION CENTER:

1-800-521-6274

HOME PAGE:

<http://www.motorola.com/semiconductors>

Information in this document is provided solely to enable system and software implementers to use Motorola products. There are no express or implied copyright licenses granted hereunder to design or fabricate any integrated circuits or integrated circuits based on the information in this document.

Motorola reserves the right to make changes without further notice to any products herein. Motorola makes no warranty, representation or guarantee regarding the suitability of its products for any particular purpose, nor does Motorola assume any liability arising out of the application or use of any product or circuit, and specifically disclaims any and all liability, including without limitation consequential or incidental damages. "Typical" parameters which may be provided in Motorola data sheets and/or specifications can and do vary in different applications and actual performance may vary over time. All operating parameters, including "Typicals" must be validated for each customer application by customer's technical experts. Motorola does not convey any license under its patent rights nor the rights of others. Motorola products are not designed, intended, or authorized for use as components in systems intended for surgical implant into the body, or other applications intended to support or sustain life, or for any other application in which the failure of the Motorola product could create a situation where personal injury or death may occur. Should Buyer purchase or use Motorola products for any such unintended or unauthorized application, Buyer shall indemnify and hold Motorola and its officers, employees, subsidiaries, affiliates, and distributors harmless against all claims, costs, damages, and expenses, and reasonable attorney fees arising out of, directly or indirectly, any claim of personal injury or death associated with such unintended or unauthorized use, even if such claim alleges that Motorola was negligent regarding the design or manufacture of the part.



Motorola and the Stylized M Logo are registered in the U.S. Patent and Trademark Office. All other product or service names are the property of their respective owners. The ARM POWERED logo is the registered trademarks of ARM Limited. ARM9, ARM920T, and ARM9TDMI are the trademarks of ARM Limited.

Motorola, Inc. is an Equal Opportunity/Affirmative Action Employer.

© Motorola, Inc. 2003

MC9328MX1/D