

# $\mu$ A798 Dual Operational Amplifier

Linear Division Operational Amplifiers

### Description

The  $\mu$ A798 consists of a monolithic pair of independent, high gain, internally frequency compensated operational amplifiers designed to operate from a single power supply or dual power supplies over a wide range of voltages. The common mode input range includes the negative supply, thereby eliminating the necessity for external biasing components in many applications. The output voltage range also includes the negative power supply voltage. The  $\mu$ A798 is constructed using the Fairchild Planar Epitaxial process.

- **Input Common Mode Voltage Range Includes Ground Or Negative Supply**
- **Output Voltage Can Swing Near Ground Or Negative Supply**
- **Internally Compensated**
- **Wide Power Supply Range Single Supply Of 3.0 V To 36 V Dual Supply of  $\pm 1.5$  V To  $\pm 18$  V**
- **Class AB Output Stage For Minimal Crossover Distortion**
- **Short Circuit Protected Output**
- **High Open Loop Gain — 200 k Typ**
- **Exceeds  $\mu$ A1458 Type Performance**
- **Operation Specified At  $\pm 15$  V And +5.0 V Power Supplies**
- **High Output Current Sink Capability**  
0.8 mA At  $V_O = 400$  mV Typ

### Absolute Maximum Ratings

Storage Temperature Range	-65°C to +150°C
Operating Temperature Range	0°C to +70°C
Lead Temperature (soldering, 10 s)	265°C
Internal Power Dissipation <sup>1, 2</sup>	
8L-Molded DIP	0.93 W
SO-8	0.81 W
Supply Voltage Between V+ and V-	36 V
Differential Input Voltage	$\pm 30$ V
Input Voltage <sup>3</sup>	-0.3 V (V-) to V+
Output Short Circuit Duration <sup>4</sup>	Indefinite

### Notes

1.  $T_J$  Max = 150°C.
2. Ratings apply to ambient temperature at 25°C. Above this temperature, derate the Molded DIP at 7.5 mW/°C, and the SO-8 at 6.5 mW/°C.
3. For supply voltage less than 30 V between V+ and V-, the absolute maximum input voltage is equal to the supply voltage.
4. Indefinite on shorts to ground or V- supply. Shorts to V+ supply may result in power dissipation exceeding the absolute maximum rating.

### Connection Diagram 8-Lead DIP and SO-8 Package (Top View)

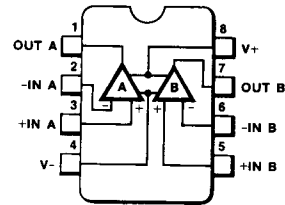

CD00090F

### Order Information

Device Code	Package Code	Package Description
$\mu$ A798SC	KC	Molded Surface Mount
$\mu$ A798TC	9T	Molded DIP

Equivalent Circuit (1/2 of circuit shown)

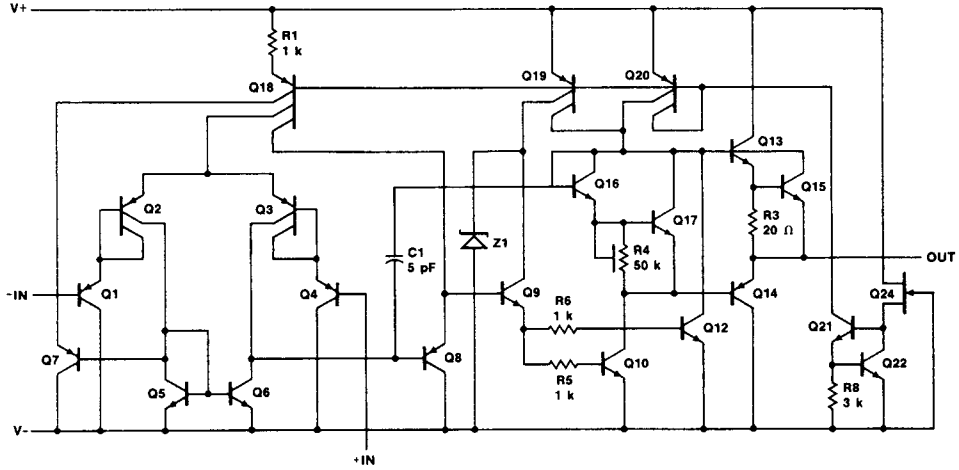

Note

1. All resistor values in ohm.

# μA798

## μA798

**Electrical Characteristics**  $T_A = 25^\circ\text{C}$ ,  $V_{CC} = \pm 15\text{ V}$ , unless otherwise specified.

Symbol	Characteristic	Condition	Min	Typ	Max	Unit
$V_{IO}$	Input Offset Voltage			2.0	6.0	mV
$I_{IO}$	Input Offset Current			10	50	nA
$I_{IB}$	Input Bias Current			50	250	nA
$Z_I$	Input Impedance		0.3	1.0		MΩ
$R_O$	Output Resistance			800		Ω
$I_{CC}$	Supply Current	$V_O = 0$ , $R_L = \infty$		2.0	4.0	mA
CMR	Common Mode Rejection	$R_S \leq 10\text{ k}\Omega$	70	90		dB
$V_{IR}$	Input Voltage Range		+13 to $V^-$	+13.5 to $V^-$		V
PSRR	Power Supply Rejection Ratio	Positive		30	150	μV/V
		Negative		30	150	
$I_{OS}$	Output Short Circuit Current <sup>1,2</sup> (Per Amplifier)	$V_O = -15\text{ V}$ , $V_{ID} = 1.0\text{ V}$	10	30	45	mA
		$V_O = \text{Gnd}$ , $V_{ID} = -1.0\text{ V}$	10	70	85	
$A_{VS}$	Large Signal Voltage Gain	$V_O = \pm 10\text{ V}$ , $R_L = 2.0\text{ k}\Omega$	20	200		V/mV
$V_{OP}$	Output Voltage Swing	$R_L = 10\text{ k}\Omega$	±13	±14		V
		$R_L = 2.0\text{ k}\Omega$	±12	±13.5		
TR	Transient Response	Rise Time	$V_O = 50\text{ mV}$ , $A_V = 1.0$ , $R_L = 10\text{ k}\Omega$		0.3	μs
		Fall Time	$V_O = 50\text{ mV}$ , $A_V = 1.0$ , $R_L = 10\text{ k}\Omega$		0.3	
		Overshoot	$V_O = 50\text{ mV}$ , $A_V = 1.0$ , $R_L = 10\text{ k}\Omega$		20	%
BW	Bandwidth	$V_O = 50\text{ mV}$ , $A_V = 1.0$ , $R_L = 10\text{ k}\Omega$		1.0		MHz
SR	Slew Rate	$V_I = -10\text{ V}$ to $+10\text{ V}$ , $A_V = 1.0$		0.6		V/μs
CS	Channel Separation	$f = 1.0\text{ kHz}$ to $20\text{ kHz}$ (Input Referenced)		-120		dB

The following specifications apply for  $0^\circ\text{C} \leq T_A \leq +70^\circ\text{C}$

$V_{IO}$	Input Offset Voltage				7.5	mV
$\Delta V_{IO}/\Delta T$	Input Offset Voltage Temperature Sensitivity			10		μV/°C
$I_{IO}$	Input Offset Current				200	nA
$\Delta I_{IO}/\Delta T$	Input Offset Current Temperature Sensitivity			50		pA/°C
$I_{IB}$	Input Bias Current				400	nA

# μA798

μA798 (Cont.)

**Electrical Characteristics**  $T_A = 25^\circ\text{C}$ ,  $V_{CC} = \pm 15\text{ V}$ , unless otherwise specified.

Symbol	Characteristic	Condition	Min	Typ	Max	Unit
$A_{VS}$	Large Signal Voltage Gain	$R_L = 2.0\text{ k}\Omega$ , $V_O = \pm 10\text{ V}$	15			V/mV
$V_{OP}$	Output Voltage Swing	$R_L = 2.0\text{ k}\Omega$	$\pm 10$			V

The following specifications apply for  $T_A = 25^\circ\text{C}$ ,  $V_+ = 5.0\text{ V}$ ,  $V_- = \text{GND}$

$V_{IO}$	Input Offset Voltage			2.0	7.5	mV
$I_{IO}$	Input Offset Current			10	50	nA
$I_{IB}$	Input Bias Current			80	250	nA
$A_{VS}$	Large Signal Voltage Gain	$R_L \geq 2.0\text{ k}\Omega$	20	200		V/mV
PSRR	Power Supply Rejection Ratio				150	$\mu\text{V/V}$
$V_{OP}$	Output Voltage Swing <sup>3</sup>	$R_L = 10\text{ k}\Omega$	4.0			$V_{p-p}$
		$5.0\text{ V} \leq V_+ \leq 30\text{ V}$ $R_L = 10\text{ k}\Omega$	(V+) -1.5			
$I_{O-}$	Output Sink Current	$V_O = 200\text{ mV}$ , $V_{ID} = 1.0\text{ V}$	0.35			mA
$I_{CC}$	Supply Current			2.0	4.0	mA

**Notes**

1. Not to exceed maximum package power dissipation.
2. Indefinite on shorts to ground or  $V_-$  supply. Shorts to  $V_+$  supply may result in power dissipation exceeding the absolute maximum rating.
3. Output will swing to ground.

7

Typical Performance Curves

Sinewave Response

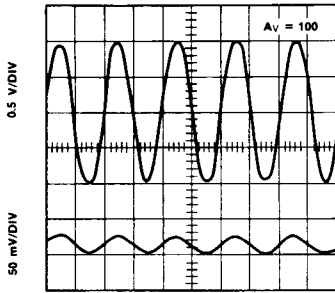

PC04541F

Output Voltage vs Frequency

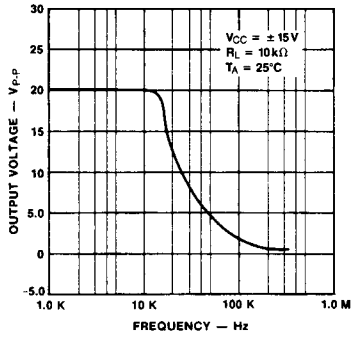

PC04551F

Open Loop Frequency Response

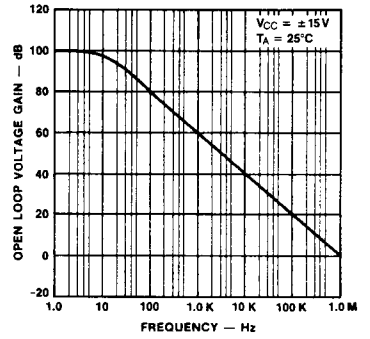

PC04561F

Output Swing vs Supply Voltage

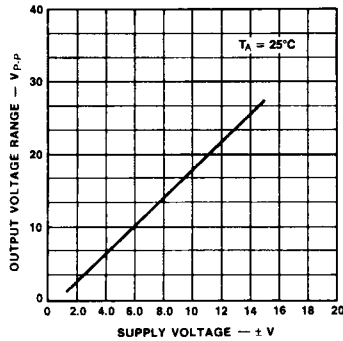

PC04571F

Input Bias Current vs Temperature

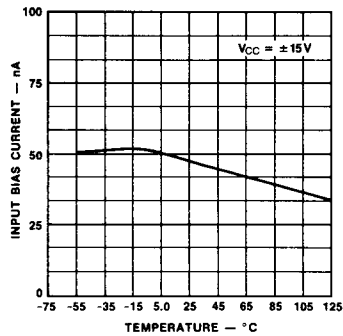

PC04580F

Input Bias Current vs Supply Voltage

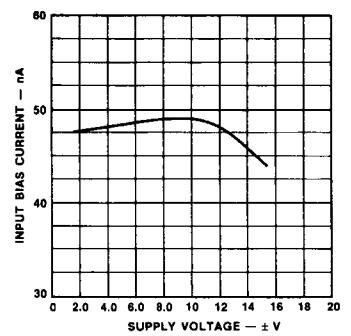

PC04591F

Typical Applications

Multiple Feedback Bandpass Filter

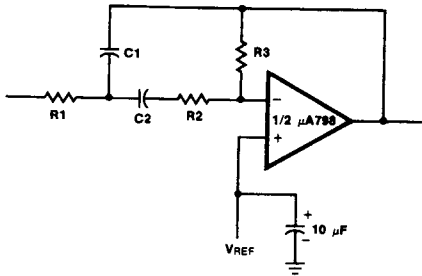

AF0061F

$f_o = \Delta$   
 $f_o =$  center frequency

$BW = \Delta$   
 BW = Bandwidth  
 R in kΩ  
 C in μF

$Q = \frac{f_o}{BW} < 10$

$C1 = C2 = \frac{Q}{3}$

$R1 = R2 = 1$   
 $R3 = 9Q^2 - 1$  } Use scaling factors in these expressions.

If source impedance is high or varies, filter may be preceded with voltage follower buffer to stabilize filter parameters.

Design example:  
 given:  $Q = 5, f_o = 1.0$  kHz  
 Let  $R1 = R2 = 10$  kΩ  
 then  $R3 = 9(5)^2 - 10$   
 $R3 = 215$  kΩ  
 $C = \frac{5}{3} = 1.6$  μF

Comparator With Hysteresis

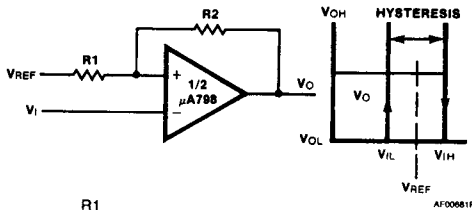

AF0061F

$V_{IL} = \frac{R1}{R1 + R2} (V_{OL} - V_{REF}) + V_{REF}$

$V_{IH} = \frac{R1}{R1 + R2} (V_{OH} - V_{REF}) + V_{REF}$

$H = \frac{R1}{R1 + R2} (V_{OH} - V_{OL})$

$f = \frac{R1 + R2}{4CR1R1}$  if  $R3 = \frac{R2R1}{R2 + R1}$

Wein Bridge Oscillator

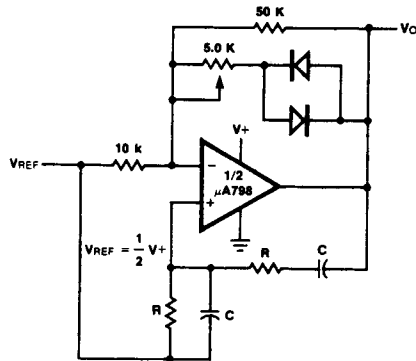

AF00671F

$f_o = \frac{1}{2\pi RC}$  for  $f_o = 1.0$  kHz  
 $R = 16$  kΩ  
 $C = 0.01$  μF

High Impedance Differential Amplifier

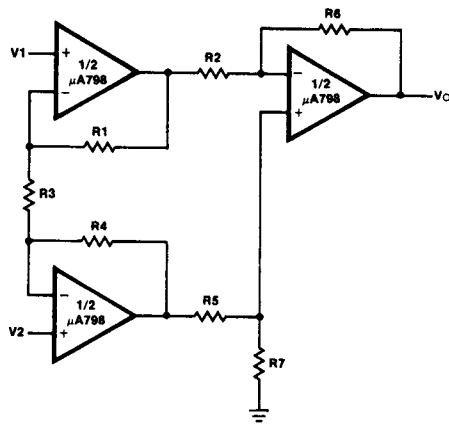

AF0061F

$V_O = C (1 + a + b)(V2 - V1)$

$\frac{R2}{R5} \cong \frac{R6}{R7}$  for best CMRR

$R1 = R4$   
 $R2 = R5$

Gain =  $\frac{R6}{R2} (1 + \frac{2R1}{R3}) = C (1 + a + b)$

Note

1. All resistor values in ohms.

Typical Applications (Cont.)

Pulse Generator

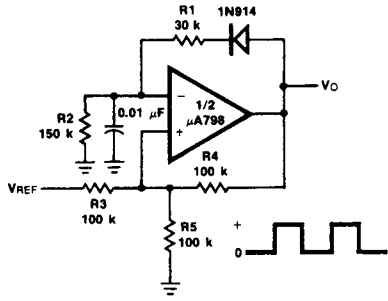

Function Generator

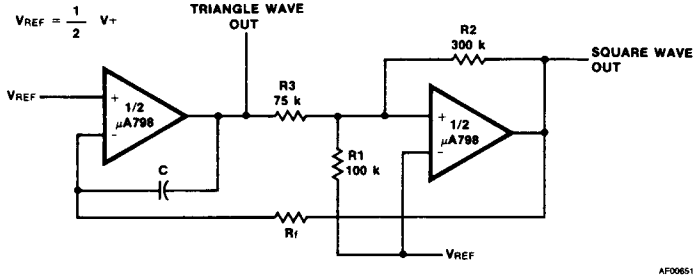

Note

- 1. All resistor values are in ohms.