

## Gas Gauge IC with SMBus-Like Interface

### Features

- Provides accurate measurement of available charge in NiCd, NiMH, and Li-Ion rechargeable batteries
- Supports SBDData charge control commands for Li-Ion, NiMH, and NiCd chemistries
- Designed for battery pack integration
  - 120µA typical operating current
  - Small size enables implementations in as little as ¼ square inch of PCB
- Two-wire SMBus-like interface
- Measurements compensated for current and temperature
- Programmable self-discharge and charge compensation
- 16-pin narrow SOIC

### General Description

The bq2092 Gas Gauge IC With SMBus-Like Interface is intended for battery-pack or in-system installation to maintain an accurate record of available battery charge. The bq2092 directly supports capacity monitoring for NiCd, NiMH, and Li-Ion battery chemistries.

The bq2092 uses the SMBus protocol that supports many of the Smart Battery Data (SBDData) commands. The bq2092 also supports SBDData charge control. Battery state-of-charge, capacity remaining, remaining time and chemistry are available over the serial link. Battery-charge state can be directly indicated using a four-segment LED display to graphically depict battery full-to-empty in 25% increments.

The bq2092 estimates battery self-discharge based on an internal timer and temperature sensor and user-programmable rate information stored in external EEPROM. The bq2092 also automatically recalibrates or “learns” battery capacity in the full course of a discharge cycle from full to empty.

The bq2092 may operate directly from three nickel chemistry cells. With the REF output and an external transistor, a simple, inexpensive regulator can be built to provide V<sub>CC</sub> for other battery cell configurations.

An external EEPROM is used to program initial values into the bq2092 and is necessary for proper operation.

### Pin Connections

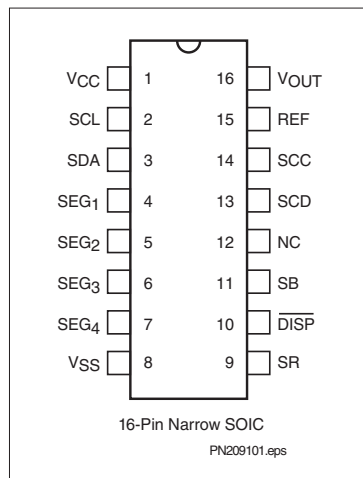

### Pin Names

V <sub>CC</sub>	3.0–5.5V	SR	Sense resistor input
SCL	Serial memory clock	$\overline{\text{DISP}}$	Display control input
SDA	Serial memory data	SB	Battery sense input
SEG <sub>1</sub>	LED segment 1	SCD	Serial communication data input/output
SEG <sub>2</sub>	LED segment 2	SCC	Serial communication clock
SEG <sub>3</sub>	LED segment 3	REF	Voltage reference output
SEG <sub>4</sub>	LED segment 4	V <sub>OUT</sub>	EEPROM supply output
V <sub>SS</sub>	System ground		

# bq2092

---

## Pin Descriptions

**VCC**      **Supply voltage input**

**SCL**      **Serial memory clock**

This output is used to clock the data transfer between the bq2092 and the external nonvolatile configuration memory.

**SDA**      **Serial memory data and address**

This bi-directional pin is used to transfer address and data to and from the bq2092 and the external configuration memory.

**SEG<sub>1</sub>–  
SEG<sub>4</sub>**      **LED display segment outputs**

Each output may activate an external LED to sink the current sourced from VCC.

**VSS**      **Ground**

**SR**      **Sense resistor input**

The voltage drop ( $V_{SR}$ ) across pins SR and VSS is monitored and integrated over time to interpret charge and discharge activity. The SR input is connected to the sense resistor and the negative terminal of the battery.  $V_{SR} < V_{SS}$  indicates discharge, and  $V_{SR} > V_{SS}$  indicates charge. The effective voltage drop,  $V_{SRO}$ , as seen by the bq2092 is  $V_{SR} + V_{OS}$  (see Table 3).

**$\overline{DISP}$**       **Display control input**

$\overline{DISP}$  high disables the LED display.  $\overline{DISP}$  floating allows the LED display to be active during charge if the rate is greater than 100mA.  $\overline{DISP}$  low activates the display for 4 seconds.

**SB**      **Secondary battery input**

This input monitors the cell pack voltage as a single-cell potential through a high-impedance resistor divider network. The cell pack voltage is reported in the SBD register function Voltage (0x09) and is compared to end-of-discharge voltage and charging voltage parameters.

**NC**      **No connect**

**SCD**      **Serial communication data**

This open-drain bidirectional pin is used to transfer address and data to and from the bq2092.

**SCC**      **Serial communication clock**

This open-drain bidirectional pin is used to clock the data transfer to and from the bq2092.

**REF**      **Reference output for regulator**

REF provides a reference output for an optional micro-regulator.

**VOUT**      **Supply output**

This output supplies power to the external EEPROM configuration memory.

## Functional Description

### General Operation

The bq2092 determines battery capacity by monitoring the amount of charge input to or removed from a rechargeable battery. The bq2092 measures discharge and charge currents, estimates self-discharge, and monitors the battery for low-battery voltage thresholds. The charge measurement is made by monitoring the voltage across a small-value series sense resistor between the battery's negative terminal and ground. The available battery charge is determined by monitoring this voltage over time and correcting the measurement for the environmental and operating conditions.

Figure 1 shows a typical battery pack application of the bq2092 using the LED capacity display, the serial port, and an external EEPROM for battery pack programming information. The bq2092 must be configured and calibrated for the battery-specific information to ensure proper operation. Table 1 outlines the externally programmable functions available in the bq2092. Refer to the Programming the bq2092 section for further details.

An internal temperature sensor eliminates the need for an external thermistor—reducing cost and components. An internal, temperature-compensated time-base eliminates the need for an external resonator, further reducing cost and components. The entire circuit in Figure 1 can occupy less than  $\frac{3}{4}$  square inch of board space.

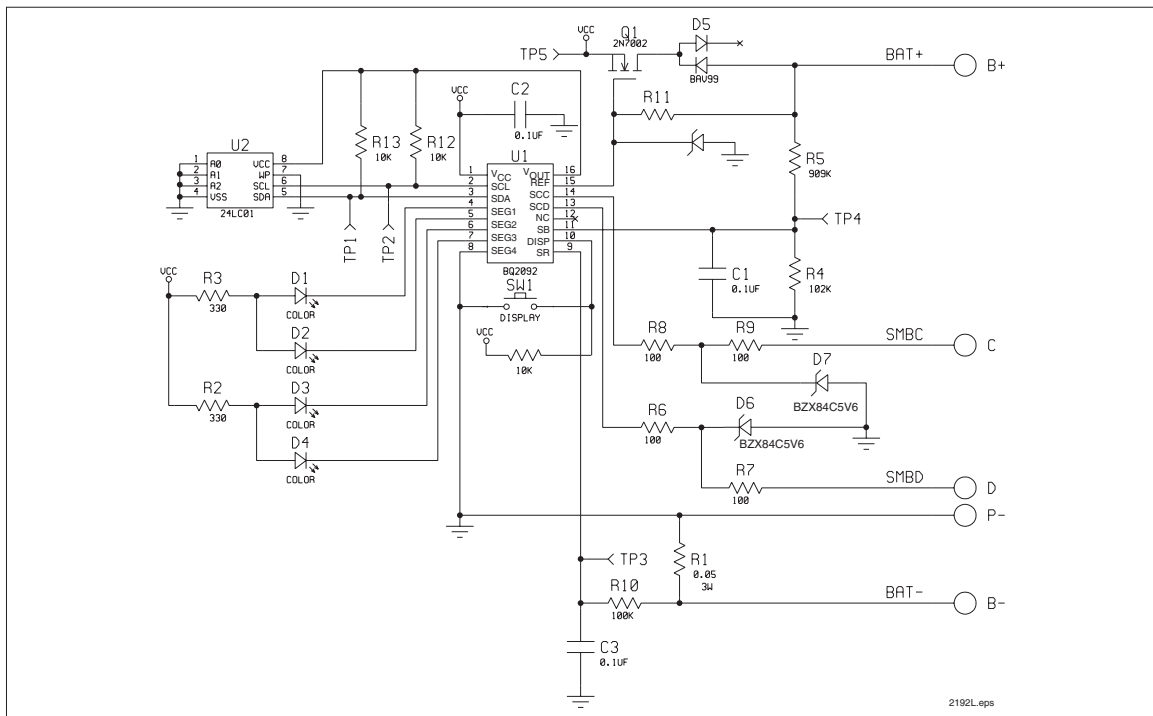

Figure 1. Battery Pack Application Diagram—LED Display

Table 1. Configuration Memory Programming Values

Parameter Name	Address	Length	Units
Design capacity	0x00/0x01	16 bits: low byte, high byte	mAh
Initial battery voltage	0x02/0x03	16 bits: low byte, high byte	mV
Fast charging current	0x04/0x05	16 bits: low byte, high byte	mA
Charging voltage	0x06/0x07	16 bit: low byte, high byte	mV
Remaining capacity alarm	0x08/0x09	16 bits: low byte, high byte	mAh
FLAGS1	0x0a	8 bits	N/A
FLAGS2	0x0b	8 bits	N/A
Current measurement gain	0x0c/0x0d	16 bits: low byte, high byte	N/A
EDV <sub>1</sub>	0x0e/0x0f	16 bits: low byte, high byte	mV
EDV <sub>F</sub>	0x10/0x11	16 bits: low byte, high byte	mV
Temperature offset	0x12	8 bits	0.1°K
Maximum charge temperature/ $\Delta T/\Delta t$	0x13	8 bits	N/A
Self-discharge rate	0x14	8 bits	N/A
Digital filter	0x15	8 bits	N/A
Current integration gain	0x16/0x17	16 bits: low byte, high byte	N/A
Full charge percentage	0x18	8 bits	N/A
Charge compensation	0x19	8 bits	N/A
Battery voltage offset	0x1a	8 bits	mV
Battery voltage gain	0x1b/0x1c	16 bits: high byte, low byte	N/A
Serial number	0x1d/0x1e	16 bits: low byte, high byte	N/A
Hold-off timer	0x1f	8 bits	N/A
Cycle count	0x20/0x21	16 bits: low byte, high byte	N/A
Maintenance charge current	0x22/0x23	16 bits: low byte, high byte	mA
Reserved	0x24/0x31	–	–
Design voltage	0x32/0x33	16 bits: low byte, high byte	mV
Specification information	0x34/0x35	16 bits: low byte, high byte	N/A
Manufacturer date	0x36/0x37	16 bits: low byte, high byte	N/A
Reserved	0x38/0x3f	–	–
Manufacturer name	0x40/0x4f	8 + 120 bits	N/A
Device name	0x50/0x5f	8 + 120 bits	N/A
Chemistry	0x60/0x6f	8 + 120 bits	N/A
Manufacturer data	0x70/0x7f	8 + 120 bits	N/A

**Note:** N/A = Not applicable; data packed or coded. See “Programming the bq2092” for details.

## Voltage Thresholds

In conjunction with monitoring  $V_{SR}$  for charge/discharge currents, the bq2092 monitors the battery potential through the SB pin. The voltage potential is determined through a resistor-divider network per the following equation:

$$\frac{R_5}{R_4} = \frac{MBV}{2.25} - 1$$

where MBV is the maximum battery voltage,  $R_5$  is connected to the positive battery terminal, and  $R_4$  is connected to the negative battery terminal.  $R_5/R_4$  should be rounded to the next highest integer. The voltage at the SB pin ( $V_{SB}$ ) should never exceed 2.4V.

The battery voltage is monitored for the end-of-discharge voltage (EDV), for maximum pack voltage and for alarm warning conditions. EDV threshold levels are used to determine when the battery has reached an “empty” state, and the charging voltage plus 5% threshold is used for fault detection during charging. The battery voltage gain, two EDV thresholds, and charge voltage limit are programmed via EEPROM. See the Programming the bq2092 section for further details.

If  $V_{SB}$  is below either of the two EDV thresholds, the associated flag is latched and remains latched, independent of  $V_{SB}$ , until the next valid charge.

EDV monitoring may be disabled under certain conditions. If the discharge current is greater than approximately 6A, EDV monitoring is disabled and resumes after the current falls below 6A.

### Reset

The bq2092 is reset when first connected to the battery pack. The bq2092 can also be reset with a command over the serial port, as described in the Software Reset section.

### Temperature

The bq2092 monitors temperature using an internal sensor. The temperature is used to adapt charge/discharge and self-discharge compensations as well as maximum temperature and  $\Delta T/\Delta t$  during bq2092 controlled charge. Temperature may also be accessed over the serial port. See the Programming the bq2092 section for further details.

## Layout Considerations

The bq2092 measures the voltage differential between the SR and  $V_{SS}$  pins.  $V_{OS}$  (the offset voltage at the SR pin) is greatly affected by PC board layout. For optimal results, the PC board layout should follow the strict rule

of a single-point ground return. Sharing high-current ground with small signal ground causes undesirable noise on the small signal nodes. Additionally, in reference to Figure 1:

- The capacitors (C1, C2, and C4) should be placed as close as possible to the SB and  $V_{CC}$  pins, and their paths to  $V_{SS}$  should be as short as possible. A high-quality ceramic capacitor of 0.1 $\mu$ f is recommended for  $V_{CC}$ .
- The sense resistor capacitor (C3) should be placed as close as possible to the SR pin.
- The sense resistor (R1) should be as close as possible to the bq2092.
- The IC should be close to the cells for the best temperature measurement.
- An optional zener may be necessary to ensure  $V_{CC}$  is not above the maximum rating during operation.

## Gas Gauge Operation

The operational overview diagram in Figure 2 illustrates the operation of the bq2092. The bq2092 accumulates a measure of charge and discharge currents, as well as an estimation of self-discharge. Charge currents are compensated for temperature and state-of-charge. Self-discharge is only temperature-compensated.

The main counter, RemainingCapacity (RM), represents the available battery capacity at any given time. Battery charging increments the RM register, whereas battery discharging and self-discharge decrement the RM register and increment the Discharge Count Register (DCR).

The Discharge Count Register (DCR) is used to update the FullChargeCapacity (FCC) register only if a complete battery discharge from full to empty occurs without any partial battery charges. Therefore, the bq2092 adapts its capacity determination based on the actual conditions of discharge.

The battery's initial capacity is equal to the DesignCapacity (DC). Until FCC is updated, RM counts up to, but not beyond, this threshold during subsequent charges.

### 1. FullChargeCapacity or learned-battery capacity:

FCC is the last measured discharge capacity of the battery. On initialization (application of  $V_{CC}$  or reset),  $FCC = DC$ . During subsequent discharges, the FCC is updated with the latest measured capacity in the Discharge Count Register, representing a discharge from full to below EDV1. A qualified discharge is necessary for a capacity transfer from the DCR to the FCC register. The FCC also serves as the 100% reference threshold used by the relative state-of-charge calculation and display.

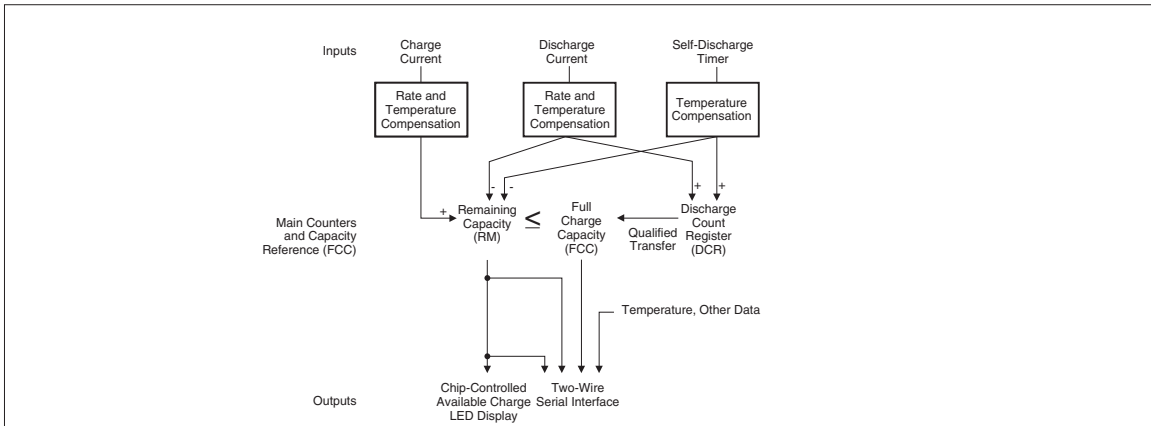

Figure 2. Operational Overview

**2. DesignCapacity (DC):**

The DC is the user-specified battery capacity and is programmed by using an external EEPROM. The DC also provides the 100% reference for the absolute display mode.

**3. Remaining Capacity (RM):**

RM counts up during charge to a maximum value of FCC and down during discharge and self-discharge to 0. RM is reset to 0000Ah when EDV1 = 1 and a valid charge is detected. To prevent overstatement of charge during periods of overcharge, RM stops incrementing when RM = FCC. RM may optionally be written to a user-defined value when fully charged when the battery pack is under bq2092 charge control. See the Charge Control section for further details.

**4. Discharge Count Register (DCR):**

The DCR counts up during discharge independent of RM and can continue increasing after RM has decremented to 0. Before RM = 0 (empty battery), both discharge and self-discharge increment the DCR. After RM = 0, only discharge increments the DCR. The DCR resets to 0 when RM = FCC. The DCR does not roll over but stops counting when it reaches FFFFh.

The DCR value becomes the new FCC value on the first charge after a valid discharge to  $V_{EDV1}$  if:

- No valid charge initiations (charges greater than 10mAh, where  $V_{SRO} > |V_{SRD}|$ ) occurred during the period between RM = FCC and EDV1 detected.
- The self-discharge count is not more than 256mAh.

- The temperature is  $\geq 273^{\circ}\text{K}$  ( $0^{\circ}\text{C}$ ) when the EDV1 level is reached during discharge.

The valid discharge flag (VDQ) indicates whether the present discharge is valid for FCC update. FCC cannot be reduced by more than 256mAh during any single cycle.

**Charge Counting**

Charge activity is detected based on a positive voltage on the VSR input. If charge activity is detected, the bq2092 increments RM at a rate proportional to  $V_{SRO}$  and, if enabled, activates an LED display. Charge actions increment the RM after compensation for charge rate and temperature.

The bq2092 determines charge activity sustained at a continuous rate equivalent to  $V_{SRO} > |V_{SRD}|$ . **A valid charge equates to sustained charge activity greater than 10 mAh.** Once a valid charge is detected, charge counting continues until  $V_{SRO}$  falls below  $|V_{SRD}|$ .  $V_{SRD}$  is a programmable threshold as described in the Digital Magnitude Filter section.

**Discharge Counting**

All discharge counts where  $V_{SRO} < |V_{SRD}|$  cause the RM register to decrement and the DCR to increment.  $V_{SRD}$  is a programmable threshold as described in the Digital Magnitude Filter section.

**Self-Discharge Estimation**

The bq2092 continuously decrements RM and increments DCR for self-discharge based on time and temperature. The self-discharge rate is dependent on the battery chemistry. The bq2092 self-discharge estimation rate is externally programmed in EEPROM

and can be programmed from 0 to 25% per day at 20-30°C. This rate doubles every 10°C increase until T > 70°C or is halved every 10°C decrease until T < 10°C.

The self-discharge estimate reduces RM by 0.39% of its current value at time intervals spaced so that the average reduction equals the programmed value adjusted for temperature. The EEPROM program constant is the 2's complement of  $52.73/X$ , where  $X = \%/day$  self-discharge rate desired at 25°C.

### Charge Control

The bq2092 supports SBD charge control by broadcasting ChargingCurrent() and ChargingVoltage() to the Smart Charger address. Smart Charger broadcasts can be disabled by writing bit 14 of Battery Mode() to 1. The bq2092-based charge control can be enabled by setting bit 4 in FLAGS2 (MSB of 0x2f) to 1. See Programming the bq2092 for further details. If the Fully\_Charged bit is not set in BatteryStatus, the bq2092 broadcasts the fast charge current and voltage to the Smart Charger. The bq2092 broadcasts the maintenance current values (trickle rate) if the Fully\_Charged bit is set or Voltage is below EDVF.

The bq2092 internal charge control is compatible with nickel-based and Li-Ion chemistries.

For Li-Ion, the bq2092 broadcasts the required ChargingCurrent and ChargingVoltage according to the values programmed in the external EEPROM. During a valid charge (VQ = 1), the bq2092 signals a valid charge termination when the Terminate\_Charge\_Alarm and Fully\_Charged bits are set in BatteryStatus. These bits are set when the battery is charged more than 256mAh above FCC.

For nickel-based chemistries, the bq2092 broadcasts the required charge current and voltage according to the programmed values in the external EEPROM. Maximum temperature and  $\Delta T/\Delta t$  are used as valid charge termination methods. **Note:** Nickel-based chemistries require a charge voltage higher than the maximum cell voltage during charge to ensure constant-current charging. During a valid charge (VQ = 1), if the bq2092 determines a maximum temperature condition, a  $\Delta T/\Delta t$  rate greater than the programmed value, or a charge state greater than 256mAh above FCC, then the Terminate\_Charge\_Alarm, Over\_Charge\_Alarm, and Fully\_Charged bits are set in BatteryStatus.

Once the bq2092 detects a valid charge termination, the Fully\_Charged bit, Terminate\_Charge\_Alarm, and Over\_Charge\_Alarm bits are set and the ChargingCurrent is set to zero. Once the terminating condition ceases, the Terminate\_Charge\_Alarm and OverCharge Alarm bits are cleared and the ChargingCurrent is set to the maintenance rate. The bq2092 requests the maintenance current and charging voltage until RM falls below the full charge

percentage. Once this occurs, the Fully\_Charged bit is cleared, and the bq2092 requests the fast charging current and charging voltage.

During fast charge, the bq2092 suspends charge by requesting zero current and setting the Terminate\_Charge\_Alarm bit in BatteryStatus. Charge is suspended if the actual charge current is 25% greater than the programmed charge current. If the programmed charge current is less than 1024mA, over-current suspend occurs if the actual charge current is 256mA greater than the programmed value. Charge is also suspended if the actual battery voltage is 5% greater than the programmed charge voltage. If the battery temperature is greater than the programmed maximum temperature before charge, then the bq2092 suspends charge requests until the temperature falls below 50°C.

If the battery temperature is less than 0°C, the charging current sets to maintenance (trickle) charge current. The fast charging current is requested when the temperature is above 5°C.

### $\Delta T/\Delta t$

The  $\Delta T/\Delta t$  used by the bq2092 is programmable in both the temperature step (1.6°C–4.6°C) and time step (20 seconds–320seconds). Typical settings for 1°C/min include 2°C over 120 seconds and 3°C over 180 seconds. Longer times are required for increased slope resolution.

$\frac{\Delta T}{\Delta t}$  is set by the formula:  $\frac{\Delta T}{\Delta t} =$

$$\left[ \left( \text{lower nibble of } 0*13 \text{ in } E^2\text{PROM} \right) * 2 + 16 \right] \left[ \frac{^\circ\text{C}}{\text{minute}} \right]$$

$$\left[ 2^s \left( \text{lower nibble of } 0*1f \text{ in } E^2\text{PROM} \right) * 3.33 \right]$$

In addition to the  $\Delta T/\Delta t$  timer, there is a hold-off timer, which starts when the battery is being charged at more than 256mA and the temperature is above 25°C. (This is valid only for NiMH chemistry, bit 5 in FLAGS2 set to 0.) Until this timer expires,  $\Delta T/\Delta t$  is suspended. If the temperature falls below 25°C, or if charging current falls below 255mA, the timer is reset and restarts only if the above conditions are once again met.

### Safety Termination

If charging continues for more than 256mAh beyond RM = FCC, the Terminate\_Charge\_Alarm and Fully\_Charged bits are set, and the charging current is modified to request maintenance current. If the battery is discharged from full by less than 256mAh, then the safety overcharge termination, for NiMH only, is allowed to extend to 512 mAh.

Updating RM after a valid charge termination, RM may optionally be set to a value from 0 to 100% of the Full-ChargeCapacity. If RM is below the value programmed



## bq2092

in full charge percentage, RM is set to full charge percentage of FCC on valid charge termination. If RM is above the full charge percentage, RM is not modified.

### Count Compensations

Charge activity is compensated for temperature and state-of-charge before updating the RM and/or DCR. RM is compensated for temperature before updating the RM register. Self-discharge estimation is compensated for temperature before updating RM or DCR.

### Charge Compensation

Charge efficiency is compensated for state-of-charge, temperature, and battery chemistry. For Li-Ion chemistry cells, the charge efficiency is unity for all cases. The charge efficiency for nickel chemistry cells, however, is adjusted using the following equation:

$$RM = RM * (Q_{EFC} - Q_{ET})$$

where  $RelativeStateofCharge \leq FullChargePercentage$

and  $Q_{EFC}$  is the programmed fast charge efficiency varying from .75 to .99.

$$RM = RM * (Q_{ETC} - Q_{ET})$$

where  $RelativeStateofCharge \geq FullChargePercentage$

and  $Q_{ETC}$  is the programmed maintenance (trickle) charge efficiency varying from 0.50 to 0.97.

$Q_{ET}$  is used to adjust the charge efficiency as the battery temperature increases according to the following:

$$Q_{ET} = 0 \text{ if } T < 30^{\circ}C$$

$$Q_{ET} = 0.02 \text{ if } 30^{\circ}C \leq T < 40^{\circ}C$$

$$Q_{ET} = 0.05 \text{ if } T \geq 40^{\circ}C$$

### Remaining Capacity Compensation

The bq2092 adjusts the RM as a function of temperature. This adjustment accounts for the reduced capacity of the battery at colder temperatures. The following equation is used to adjust RM:

If  $T \geq 5^{\circ}C$

$$\begin{aligned} \text{RemainingCapacity} = \\ \text{Nominal Available Capacity (NAC)} \end{aligned}$$

If  $T < 5^{\circ}C$

$$RM() = NAC() (1 + TCC * (T - 5^{\circ}C))$$

Where  $T = \text{temperature } ^{\circ}C$

$$TCC = 0.004$$

**Table 2. Typical Digital Filter Settings**

DMF	DMF Hex.	V <sub>SRD</sub> (mV)
75	4B	±0.60
100	64	±0.45
150 (default)	96	±0.30
175	AF	±0.26
200	C8	±0.23

RM adjusts upward to Nominal Available Capacity as the temperature increases.

### Digital Magnitude Filter

The bq2092 has a programmable digital filter to eliminate charge and discharge counting below a set threshold. Table 2 shows typical digital filter settings. The proper digital filter setting can be calculated using the following equation.

$$|V_{SRD} \text{ (mV)}| = 45 / DMF$$

## Error Summary

### Capacity Inaccurate

The FCC is susceptible to error on initialization or if no updates occur. On initialization, the FCC value includes the error between the design capacity and the actual capacity. This error is present until a valid discharge occurs and FCC is updated (see the DCR description on page 6). The other cause of FCC error is battery wear-out. As the battery ages, the measured capacity must be adjusted to account for changes in actual battery capacity. Periodic discharges from full to empty will minimize errors in FCC.

### Current-Sensing Error

Table 3 illustrates the current-sensing error as a function of  $V_{SR}$ . A digital filter eliminates charge and discharge counts to the RM register when  $V_{SR0}$  is between  $V_{SRQ}$  and  $V_{SRD}$ .

### Display

The bq2092 can directly display capacity information using low-power LEDs. The bq2092 displays the battery charge state in either absolute or relative mode. In relative mode, the battery charge is represented as a percentage of the FCC. Each LED segment represents 25% of the FCC.



**Table 3. bq2092 Current-Sensing Errors**

Symbol	Parameter	Typical	Maximum	Units	Notes
V <sub>OS</sub>	Offset referred to V <sub>SR</sub>	± 50	± 150	μV	$\overline{\text{DISP}} = V_{CC}$ .
INL	Integrated non-linearity error	± 2	± 4	%	Add 0.1% per °C above or below 25°C and 1% per volt above or below 4.25V.
INR	Integrated non-repeatability error	± 1	± 2	%	Measurement repeatability given similar operating conditions.

In absolute mode, each segment represents a fixed amount of charge, 25% of the design capacity. As the battery wears out over time, it is possible for the FCC to be below the design capacity. In this case, all of the LEDs may not turn on in absolute mode, representing the reduction in the actual battery capacity.

The displayed capacity is compensated for the present battery temperature. The displayed capacity varies as temperature varies, indicating the available charge at the present conditions.

When  $\overline{\text{DISP}}$  is tied to V<sub>CC</sub>, the SEG<sub>1-4</sub> outputs are inactive. When  $\overline{\text{DISP}}$  is left floating, the display becomes active whenever the bq2092 detects a charge rate of 100mA or more. When pulled low, the segment outputs become active immediately for a period of approximately 4 seconds. The  $\overline{\text{DISP}}$  pin must be returned to float or V<sub>CC</sub> to reactivate the display.

The segment outputs are modulated as two banks of two, with segments 1 and 3 alternating with segments 2 and 4. The segment outputs are modulated at approximately 100Hz with each segment bank active for 30% of the period.

SEG<sub>1</sub> blinks at a 4Hz rate whenever V<sub>SB</sub> has been detected to be below V<sub>EDV1</sub> (EDV<sub>1</sub> = 1), indicating a low-battery condition. V<sub>SB</sub> below V<sub>EDVF</sub> (EDV<sub>F</sub> = 1) disables the display output.

## Microregulator

The bq2092 can operate directly from three nickel chemistry cells. To facilitate the power supply requirements of the bq2092, an REF output is provided to regulate an external low-threshold n-FET. A micropower source for the bq2092 can be inexpensively built using the FET and an external resistor; see Figure 1. Note that an optional zener diode may be necessary to limit V<sub>CC</sub> during charge.

## Communicating With the bq2092

The bq2092 includes a simple two-pin (SCC and SCD) bidirectional serial data interface. A host processor uses

the interface to access various bq2092 registers; see Table 4. This allows battery characteristics to be easily monitored. The open-drain SCD and SCC pins on the bq2092 are pulled up by the host system, or may be connected to V<sub>SS</sub>, if the serial interface is not used.

The interface uses a command-based protocol, where the host processor sends the battery address and an eight-bit command byte to the bq2092. The command directs the bq2092 to either store the next data received to a register specified by the command byte or output the data specified by the command byte.

## bq2092 Data Protocols

The host system, acting in the role of a Bus master, uses the read word and write word protocols to communicate integer data with the bq2092. (See Figure 3.)

### Host-to-bq2092 Message Protocol

The Bus Host communicates with the bq2092 using one of three protocols:

- Read word
- Write word
- Read block

The particular protocol used is a function of the command. The protocols used are shown in Figure 3.

## Host-to-bq2092 Messages (see Table 4)

### ManufacturerAccess() (0x00)

This optional function is not operational for the bq2092.

### RemainingCapacityAlarm() (0x01)

This function sets or returns the low-capacity alarm value. When RM falls below the RemainingCapacityAlarm value, the Remaining\_Capacity\_Alarm bit is set in BatteryStatus (0x16). The system may alter this alarm value during operation.

## bq2092

**Table 4. bq2092 Register Functions**

Function	Code	Access	Units	Defaults <sup>1</sup>
ManufacturerAccess	0x00	read/write	-	-
RemaningCapacityAlarm	0x01	read/write	unsigned int.	E <sup>2</sup>
RemainingTimeAlarm	0x02	read/write	unsigned int.	10
BatteryMode	0x03	read/write	bit flag	-
Temperature	0x08	read	0.1°K	-
Voltage	0x09	read	mV	-
Current	0x0a	read	mA	0000h
AverageCurrent	0x0b	read	mA	0000h
MaxError	0x0c	read	percent	100
RelativeStateOfCharge	0x0d	read	percent	0000h
AbsoluteStateOfCharge	0x0e	read	percent	0000h
RemainingCapacity	0x0f	read	mAh	0000h
FullChargeCapacity	0x10	read	mAh	E <sup>2</sup>
RunTimeToEmpty	0x11	read	minutes	-
AverageTimeToEmpty	0x12	read	minutes	-
Reserved	0x13	-	-	-
ChargingCurrent	0x14	read	mA	E <sup>2</sup>
ChargingVoltage	0x15	read	mV	E <sup>2</sup>
BatteryStatus	0x16	read	number	0000h
CycleCount	0x17	read	count	E <sup>2</sup>
DesignCapacity	0x18	read	mAh	E <sup>2</sup>
DesignVoltage	0x19	read	mV	E <sup>2</sup>
SpecificationInfo	0x1a	read	number	E <sup>2</sup>
ManufactureDate	0x1b	read	unsigned int	E <sup>2</sup>
SerialNumber	0x1c	read	number	E <sup>2</sup>
Reserved	0x1d - 0x1f	-	-	-
ManufacturerName	0x20	read	string	E <sup>2</sup>
DeviceName	0x21	read	string	E <sup>2</sup>
DeviceChemistry	0x22	read	string	E <sup>2</sup>
ManufacturerData	0x23	read	string	E <sup>2</sup>
FLAGS1 and FLAGS2	0x2f	read	bit flag	E <sup>2</sup>
Endof DischargeVoltage1	0x3e	read	mV	E <sup>2</sup>
EndofDischargeVoltageFinal	0x3f	read	mV	E <sup>2</sup>

**Note:** 1. Defaults after reset or power-up.

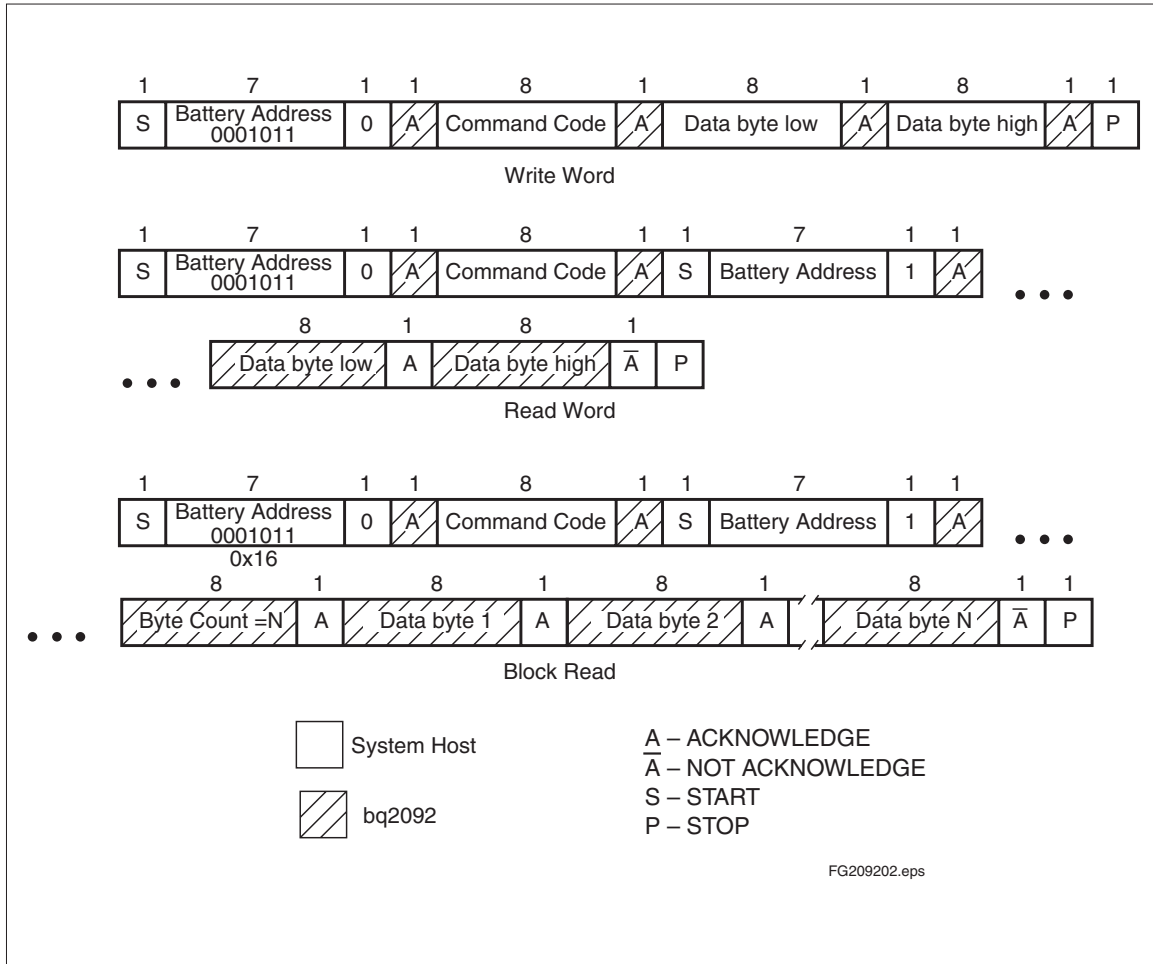

Figure 3. Host Communication Protocols

## bq2092

---

Input/Output: unsigned integer. This sets/returns the value where the Remaining Capacity Alarm bit is set in BatteryStatus.

### RemainingTimeAlarm() (0x02)

This function sets or returns the low remaining time alarm value. When the AverageTimeToEmpty (0x12) falls below this value, the Remaining\_Time\_Alarm bit in BatteryStatus is set. The default value for this register is set in EEPROM. The system may alter this alarm value during operation.

Input/Output: unsigned integer. This sets/returns the value where the Remaining\_Time\_Alarm bit is set in BatteryStatus.

### BatteryMode() (0x03)

This read/write word selects the various battery operational modes. The bq2092 supports the battery capacity information specified in mAh. This function also determines whether the bq2092 charging values are broadcasted to the Smart Battery Charger address.

Writing bit 14 to 1 disables voltage and current Smart Battery Charger messages. Bit 14 is reset to 0 once the pack is removed from the system (SCC and SCD = 0 for greater than 2 seconds.)

Writing bit 13 to 1 disables all Smart Battery Charger messages including alarm messages. This bit remains set until overwritten. Programming bit 3 of FLAGS2 in EEPROM (EE 0x0b) initializes bit 13 of BatteryMode to 1.

### Temperature() (0x08)

This read-only word returns the cell-pack's internal temperature (0.1°K).

Output: unsigned integer. Returns cell temperature in tenths of degrees Kelvin increments

Units: 0.1°K

Range: 0 to +500.0°K

Granularity: 0.5°K or better

Accuracy: ±3°K after calibration

### Voltage() (0x09)

This read-only word returns the cell-pack voltage (mV).

Output: unsigned integer. Returns battery terminal voltage in mV

Units: mV

Range: 0 to 65,535 mV

Granularity: 0.2% of DesignVoltage

Accuracy: ±1% of DesignVoltage after calibration

### Current() (0x0a)

This read-only word returns the current through the battery's terminals (mA).

Output: signed integer. Returns the charge/discharge rate in mA, where positive is for charge and negative is for discharge

Units: mA

Range: 0 to 32,767 mA for charge or 0 to -32,768 mA for discharge

Granularity: 0.2% of the DesignCapacity or better

Accuracy: ±1% of the DesignCapacity after calibration

### AverageCurrent() (0x0b)

This read-only word returns a rolling average of the current through the battery's terminals. For the bq2092 Current = AverageCurrent. The AverageCurrent function returns meaningful values after the battery's first minute of operation.

Output: signed integer. Returns the charge/discharge rate in mA, where positive is for charge and negative is for discharge

Units: mA

Range: 0 to 32,767 mA for charge or 0 to -32,768 mA for discharge

Granularity: 0.2% of the DesignCapacity or better

Accuracy: ±1% of the DesignCapacity after calibration

### MaxError() (0x0c)

This read-only word returns the expected margin of error (%).

Output: unsigned integer. Returns percent uncertainty

Units: %

Range: 0 to 100%

### RelativeStateOfCharge() (0x0d)

This read-only word returns the predicted remaining battery capacity expressed as a percentage of FullChargeCapacity (%). **RelativeStateOfCharge is only valid for battery capacities less than 10,400mAh.**

Output: unsigned integer. Returns the percent of remaining capacity

Units: %

Range: 0 to 100%

Granularity: 1%

### AbsoluteStateOfCharge() (0x0e)

This read-only word returns the predicted remaining battery capacity expressed as a percentage of DesignCapacity (%). Note that AbsoluteStateOfCharge can return values greater than 100%. **Absolute StateOfCharge is only valid for battery capacities less than 10,400mAh.**

Output: unsigned integer. Returns the percent of remaining capacity.

Units: %

Range: 0 to 65,535 %

Granularity: 1% or better

Accuracy:  $\pm$ MaxError

### RemainingCapacity() (0x0f)

This read-only word returns the predicted remaining battery capacity. The RemainingCapacity value is expressed in mAh.

Output: unsigned integer. Returns the estimated remaining capacity in mAh.

Units: mAh

Range: 0 to 65,535 mAh

Granularity: 0.2% of DesignCapacity or better

### FullChargeCapacity() (0x10)

This read-only word returns the predicted pack capacity when it is fully charged. FullChargeCapacity defaults to the value programmed in the external EEPROM until a new pack capacity is learned.

Output: unsigned integer. Returns the estimated full charge capacity in mAh.

Units: mAh

Range: 0 to 65,535 mAh

Granularity: 0.2% of DesignCapacity or better

### RunTimeToEmpty() (0x11)

This read-only word returns the predicted remaining battery life at the present rate of discharge (minutes). The RunTimeToEmpty() value is calculated based on Current().

Output: unsigned integer. Returns the minutes of operation left.

Units: minutes

Range: 0 to 65,534 minutes

Granularity: 2 minutes or better

Invalid data indication: 65,535 indicates battery is not being discharged

### AverageTimeToEmpty() (0x12)

This read-only word returns the predicted remaining battery life at the present average discharge rate (minutes). The AverageTimeToEmpty is calculated based on AverageCurrent.

Output: unsigned integer. Returns the minutes of operation left.

Units: minutes

Range: 0 to 65,534 minutes

Granularity: 2 minutes or better

Invalid data indication: 65,535 indicates battery is not being charged

### ChargingCurrent() (0x14)

If enabled, the bq2092 sends the desired charging rate in mA to the Smart Battery Charger.

Output: unsigned integer. Transmits/returns the maximum charger output current in mA.

Units: mA

Range: 0 to 65,534 mA

Granularity: 0.2% of the design capacity or better

Invalid data indication: 65,535 indicates that the Smart Charger should operate as a voltage source outside its maximum regulated current range.

### ChargingVoltage() (0x15)

If enabled, the bq2092 sends the desired voltage in mV to the Smart Battery Charger.

Output: unsigned integer. Transmits/returns the charger voltage output in mV.

Units: mV

Range: 0 to 65,534mV

Granularity: 0.2% of the DesignVoltage or better

Invalid data indication: 65,535 indicates that the Smart Battery Charger should operate as a cur-

## bq2092

rent source outside its maximum regulated voltage range.

### BatteryStatus() (0x16)

This read-only word returns the BatteryStatus word.

Output: unsigned integer. Returns the status register with alarm conditions bitmapped as shown in Table 5.

Some of the BatteryStatus flags (Remaining\_Capacity\_Alarm and Remaining\_Time\_Alarm) are calculated based on current. See Table 8 for definitions.

### CycleCount() (0x17)

This read-only word returns the number of charge/discharge cycles the battery has experienced. A charge/discharge cycle starts from a base value equivalent to the battery's state-of-charge, on completion of a charge cycle. The bq2092 increments the cycle counter during the current charge cycle, if the battery has been discharged 15% below the state-of-charge at the end of the last charge cycle. This prevents false reporting of small charge/discharge cycles.

Output: unsigned integer. Returns the count of charge/discharge cycles the battery has experienced.

Units: cycles

Range: 0 to 65,535 cycles; 65,535 indicates battery has experienced 65,535 or more cycles

Granularity: 1 cycle

### DesignCapacity() (0x18)

This read-only word returns the theoretical capacity of a new pack. The DesignCapacity() value is expressed in mAh at the nominal discharge rate.

Output: unsigned integer. Returns the battery capacity in mAh.

Units: mAh

Range: 0 to 65,535 mAh

### DesignVoltage() (0x19)

This read-only word returns the theoretical voltage of a new pack in mV.

Output: unsigned integer. Returns the battery's normal terminal voltage in mV.

Units: mV

Range: 0 to 65,535 mV

### SpecificationInfo() (0x1a)

This read-only word returns the specification revision the bq2092 supports. It is typically set to all zeros to represent non-Rev 1.0 compliance to the SMBus specification output: unsigned integer.

### ManufactureDate() (0x1b)

This read-only word returns the date the cell was manufactured in a packed integer word. The date is packed as follows: (year - 1980) \* 512 + month \* 32 + day.

Field	Bits Used	Format	Allowable Value
Day	0–4	5-bit binary value	1–31 (corresponds to date)
Month	5–8	4-bit binary value	1–12 (corresponds to month number)
Year	9–15	7-bit binary value	0–127 (corresponds to year biased by 1980)

Table 5. Status Register

Alarm Bits	
0x8000	Overcharge_Alarm
0x4000	Terminate_Charge_Alarm
0x2000	Reserved
0x1000	Over_Temp_Alarm
0x0800	Terminate_Discharge_Alarm
0x0400	Reserved
0x0200	Remaining_Capacity_Alarm
0x0100	Remaining_Time_Alarm
Status Bits	
0x0080	Initialized
0x0040	Discharging
0x0020	Fully_Charged
0x0010	Fully_Discharged
Error Code	
0x0000-0x000f	Reserved for error codes

### SerialNumber() (0x1c)

This read-only word returns a serial number. This number, when combined with the ManufacturerName, the DeviceName, and the ManufactureDate, uniquely identifies the battery.

Output: unsigned integer

**ManufacturerName() (0x20)**

This read-only string returns a character string where the first byte is the number of characters available. The maximum number of characters is 15. The character string contains the battery manufacturer's name. For example, "Unitrode" identifies the battery pack manufacturer as Unitrode.

Output: string or ASCII character string

**DeviceName() (0x21)**

This read-only string returns a character string where the first byte is the number of characters available. The maximum number of characters is 15. The 15-byte character string contains the battery's name. For example, a DeviceName of "bq2092" indicates that the battery is a model bq2092.

Output: string or ASCII character string

**DeviceChemistry() (0x22)**

This read-only string returns a character string where the first byte is the number of characters available. The maximum number of characters is 15. The 15-byte character string contains the battery's chemistry. For example, if the DeviceChemistry function returns "NiMH," the battery pack contains nickel-metal hydride cells.

Output: string or ASCII character string

**ManufacturerData() (0x23)**

This read-only string allows access to an up to 15-byte manufacturer data string.

Output: block data—data whose meaning is assigned by the Smart Battery's manufacturer.

**EndofDischargeVoltage1() (0x3e)**

This read-only word returns the first end-of-discharge voltage programmed for the pack.

Output: two's complemented unsigned integer. Returns battery end-of-discharge voltage programmed in EEPROM in mV.

**EndofDischargeVoltageF() (0x3f)**

This read-only word returns the final end-of-discharge voltage programmed for the pack.

Output: two's complemented unsigned integer. Returns battery final end-of-discharge voltage programmed in EEPROM in mV.

**FLAGS1&2() (0x2f)**

This read-only register returns an unsigned integer representing the internal status registers of the bq2092. The MSB represents FLAGS2, and the LSB represents FLAGS1. See Table 6 for the bit description for FLAGS1 and FLAGS2.

**FLAGS2**

The *Display Mode* flag (DMODE), bit 7, determines whether the bq2092 displays Relative or Absolute capacity.

The DMODE values are:

FLAGS2 Bits							
7	6	5	4	3	2	1	0
DMODE	-	-	-	-	-	-	-

Where DMODE is:

- 0 Selects Absolute display
- 1 Selects Relative display

Bit 6 is reserved.

The *Chemistry* flag (CHM), bit 5, selects Li-Ion or nickel compensation factors.

The CHM values are:

FLAGS2 Bits							
7	6	5	4	3	2	1	0
-	-	CHM	-	-	-	-	-

**Table 6. Bit Descriptions for FLAGS1 and FLAGS2**

	(MSB) 7	6	5	4	3	2	1	0 (LSB)
FLAGS2	DMODE	-	CHM	CC	-	OV	LTF	OC
FLAGS1	-	-	VQ	WRINH	VDQ	SEDV	EDV1	EDVF

**Note:** - = Reserved



# bq2092

Where CHM is:

- 0 Selects Nickel
- 1 Selects Li-Ion

Bit 4, the *Charge Control* flag (CC), determines whether a bq2092-based charge termination will set RM to a user-defined programmable full charge capacity.

The CC values are:

FLAGS2 Bits							
7	6	5	4	3	2	1	0
-	-	-	CC	-	-	-	-

Where CC is:

- 0 RM is not modified on valid bq2092 charge termination
- 1 RM is set to a programmable percentage of the FCC when a valid bq2092 charge termination occurs

Bit 3 is reserved.

Bit 2, the *Overvoltage* flag (OV), is set when the bq2092 detects a pack voltage 5% greater than the programmed charging voltage. This bit is cleared when the pack voltage falls 5% below the programmed charging voltage.

The OV values are:

FLAGS2 Bits							
7	6	5	4	3	2	1	0
-	-	-	-	-	OV	-	-

Where OV is:

- 0  $\text{BatteryVoltage}() < 1.05 * \text{ChargingVoltage}$
- 1  $\text{BatteryVoltage}() \geq 1.05 * \text{ChargingVoltage}$

Bit 1, the *Low Temperature Fault* flag (LTF), is set when temperature  $< 0^{\circ}\text{C}$  and cleared when temperature  $> 5^{\circ}\text{C}$ .

The LTF values are:

Where LTF is:

- 0 Temperature  $> 5^{\circ}\text{C}$
- 1 Temperature  $< 0^{\circ}\text{C}$

Bit 0, the *Overcurrent* flag (OC), is set when the average current is 25% greater than the programmed charging current. If the charging current is programmed less than 1024mA, overcurrent is set if the average current is 256mA greater than the programmed charging current.

This flag is cleared when the average current falls below 256mA.

The OC values are:

FLAGS2 Bits							
7	6	5	4	3	2	1	0
-	-	-	-	-	-	-	OC

Where OC is:

- 0 Average current is less than  $1.25 * \text{charging current}$  or less than 256mA if charging current is programmed less than 1024mA
- 1 Average current exceeds  $1.25 * \text{charging current}$  or 256mA if the charging current is programmed less than 1024mA. This bit is cleared if average current  $< 256\text{mA}$

## FLAGS1

Bits 7 and 6 are reserved. The *Valid Charge* flag (VQ), bit 5, is set when  $V_{\text{SRO}} \geq |V_{\text{SRD}}|$  and 10mAh of charge has accumulated. This bit is cleared during a discharge and when  $V_{\text{SRO}} \leq |V_{\text{SRD}}|$ .

The VQ values are:

FLAGS1 Bits							
7	6	5	4	3	2	1	0
-	-	VQ	-	-	-	-	-

Where VQ is:

- 0  $V_{\text{SRO}} \leq |V_{\text{SRD}}|$
- 1  $V_{\text{SRO}} \geq |V_{\text{SRD}}|$  and 10mAh of charge has accumulated

The *Write Inhibit* flag (WRINH), bit 4, allows or inhibits writes to all registers.

The WRINH values are:

FLAGS1 Bits							
7	6	5	4	3	2	1	0
-	-	-	WRINH	-	-	-	-

Where WRINH is:

- 0 Allows writes to all registers
- 1 Inhibits all writes and secures the bq2092 from invalid/undesired writes.

WRINH should be set at the time of pack assembly and tested to prevent special read-write registers from accidental over-writing.

The *Valid Discharge* flag (VDQ), bit 3, is set when a valid discharge is occurring (discharge cycle valid for learning new full charge capacity) and cleared if a partial charge is detected, EDV1 is asserted when  $T < 0^{\circ}\text{C}$ , or self-discharge accounts for more than 256mAh of the discharge.

The VDQ values are:

FLAGS1 Bits							
7	6	5	4	3	2	1	0
-	-	-	-	VDQ	-	-	-

Where VDQ is:

- 0 Self-discharge is greater than 256mAh, EDV1 = 1 when  $T < 0^{\circ}\text{C}$  or  $VQ = 1$
- 1 On first discharge after RM=FCC

The *Stop EDV* flag (SEDV), bit 2, is set when the discharge current  $> 6.15\text{A}$  and cleared when the discharge current falls below 6.15A.

The SEDV values are:

FLAGS1 Bits							
7	6	5	4	3	2	1	0
-	-	-	-	-	SEDV	-	-

Where SEDV is:

- 0 Current  $< 6.15\text{A}$
- 1 Current  $> 6.15\text{A}$

The *First End-of-Discharge Voltage* flag (EDV1), bit 1, is set when Voltage  $< EDV1 = 1$  if SEDV = 0 and cleared when  $VQ = 1$  and Voltage  $> EDV1$ .

The EDV1 values are:

FLAGS1 Bits							
7	6	5	4	3	2	1	0
-	-	-	-	-	-	EDV1	-

Where EDV1 is:

- 0  $VQ = 1$  and Voltage  $> EDV1$
- 1 Voltage  $< EDV1$  and SEDV = 0

The *Final End-of-Discharge Voltage* flag (EDVF), bit 0, is set when Voltage  $< EDVF = 1$  if SEDV = 0 and cleared when  $VQ = 1$  and Voltage  $> EDVF$ .

The EDVF values are:

FLAGS1 Bits							
7	6	5	4	3	2	1	0
-	-	-	-	-	-	-	EDVF

Where EDVF is:

- 0  $VQ = 1$  and Voltage  $> EDVF$
- 1 Voltage  $< EDVF$  and SEDV = 0

## Software Reset

The bq2092 can be reset over the serial port by confirming that the WRINH bit is set to zero in FLAGS1, writing MaxError (0x0c) to any value other than 2, and writing the reset register (0x44) to 8009, causing the bq2092 to reinitialize and read the default values from the external EEPROM.

## Error Codes and Status Bits

Error codes and status bits are listed in Table 7 and Table 8, respectively.

## Programming the bq2092

The bq2092 requires the proper programming of an external EEPROM for proper device operation. Each module can be calibrated for the greatest accuracy, or general “default” values can be used. A programming kit (interface board, software, and cable) for an IBM-compatible PC is available from Unitrode. Please contact Unitrode for further details

The bq2092 uses a 24LC01 or equivalent serial EEPROM for storing the various initial values, calibration data, and string information. Table 1 outlines the parameters and addresses for this information. Tables 9 and 10 detail the various register contents and show an example program value for an 1800mAh NiMH battery pack, using a 50mΩ sense resistor.

## bq2092

---

**Table 7. Error Codes (BatteryStatus() (0x16))**

<b>Error</b>	<b>Code</b>	<b>Access</b>	<b>Description</b>
OK	0x0000	read/write	bq2092 processed the function code without detecting any errors
Busy	0x0001	read/write	bq2092 is unable to process the function code at this time
NotReady	0x0002	read/write	bq2092 cannot read or write the data at this time—try again later
UnsupportedCommand	0x0003	read/write	bq2092 does not support the requested function code
AccessDenied	0x0004	write	bq2092 detected an attempt to write to a read-only function code
Overflow/Underflow	0x0005	read/write	bq2092 detected a data overflow or underflow
BadSize	0x0006	write	bq2092 detected an attempt to write to a function code with an incorrect size data block
UnknownError	0x0007	read/write	bq2092 detected an unidentifiable error

**Note:** Reading the bq2092 after an error clears the error code.

Table 8. Status Bits

Alarm Bits		
Bit Name	Set When:	Reset When:
OVER_CHARGE_ALARM	bq2092 detects over-temperature or $\Delta T/\Delta t$ . ( <b>Note: valid charge termination</b> ).	A discharge occurs or when $\Delta T/\Delta t$ , or over-temperature, ceases during charge.
TERMINATE_CHARGE_ALARM	bq2092 detects over-current, over-voltage, over-temperature, or $\Delta T/\Delta t$ conditions exist during charge. Charging current is set to zero, indicating a charge suspend.	A discharge occurs or when all conditions causing the event cease.
$\Delta T/\Delta t$ _ALARM	bq2092 detects the rate-of-temperature increase is above the programmed value (valid termination)	The temperature rise falls below the programmed rate.
OVER_TEMP_ALARM	bq2092 detects that its internal temperature is greater than the programmed value (valid termination).	Internal temperature falls below 50°C.
TERMINATE_DISCHARGE_ALARM	bq2092 determines that it has supplied all the charge that it can without being damaged (EDVF).	$V_{BAT} > V_{EDVF}$ signifying that the battery has reached a state of charge sufficient for it to once again safely supply power.
REMAINING_CAPACITY_ALARM	bq2092 detects that the RemainingCapacity() is less than that set by the RemainingCapacity() function.	Either the value set by the RemainingCapacityAlarm() function is lower than the RemainingCapacity() or the RemainingCapacity() is increased by charging.
REMAINING_TIME_ALARM	bq2092 detects that the estimated remaining time at the present discharge rate is less than that set by the RemainingTimeAlarm() function.	Either the value set by the RemainingTimeAlarm() function is lower than the AverageTimeToEmpty() or a valid charge is detected.
Status Bits		
Bit Name	Set When:	Reset When:
INITIALIZED	bq2092 is set when the bq2092 has reached a full or empty state.	Battery detects that power-on or user-initiated reset has occurred.
DISCHARGING	bq2092 determines that it is not being charged.	Battery detects that it is being charged.
FULLY_CHARGED	bq2092 determines a valid charge termination. RM will then be set to full charge percentage if necessary.	RM discharges below the full charge percentage
FULLY_DISCHARGED	bq2092 determines that it has supplied all the charge that it can without being damaged (that is, continued use will result in permanent capacity loss to the battery)	RelativeStateOfCharge is greater than or equal to 20%

## bq2092

**Table 9. Example Register Contents**

Description	EEPROM Address		EEPROM Hex Contents		Example Values	Notes
	Low Byte	High Byte	Low Byte	High Byte		
Design Capacity	0x00	0x01	08	07	1800mAh	This sets the initial full charge battery capacity stored in FCC. FCC is updated with the actual full to empty discharge capacity after a valid discharge from RM = FCC to Voltage() = EDV1.
Initial Battery Voltage	0x02	0x03	30	2a	10800mV	This register is used to set the battery voltage on reset.
Fast charging current	0x04	0x05	08	07	1800mA	This register is used to set the fast charge current for the Smart Charger.
Fast charging voltage	0x06	0x07	c4	3b	15300mV	This register is used to set the fast charge voltage for the Smart Charger.
Remaining Capacity Alarm	0x08	0x09	b4	00	180mAh	This value represents the low capacity alarm value.
FLAGS1	0x0a		10			FLAGS1 should be set to 10h before pack shipment to inhibit undesirable writes to the bq2092. (WRINH = 1.)
FLAGS2	0x0b		90		Li-Ion = b0h NiMH = 90h	See FLAGS2 register for the bit description and the proper value for programming FLAGS2. Selects relative display mode, selects NiMH compensation factors, and enables bq2092 Smart Charger control.
Current Measurement Gain <sup>1</sup>	0x0c	0x0d	ee	02	37.5/05	The current gain measurement and current integration gain are related and defined for the bq2092 current measurement. 0x0c = 37.5/sense resistor value in ohms.
EDV1	0x0e	0x0f	16	db	9450mV (1.05V/cell)	The value programmed is the two's complement of the threshold voltage in mV.
EDVF	0x10	0x11	d8	dc	9000mV (1.0V/cell)	The value programmed is the two's complement of the threshold voltage in mV.

**Note:** 1. Can be adjusted to calibrate the battery pack.

Table 9. Example Register Contents (Continued)

Description	EEPROM Address		EEPROM Hex Contents		Example Values	Notes
	Low Byte	High Byte	Low Byte	High Byte		
Temperature Offset <sup>1</sup>	0x12		32		5.0°C	The default value is 0x80 (12.8° + nominal value). Actual temp (20°C) = Nominal temp. (15°C) - temp. offset (5°C) where temperature determined by the bq2092 can be adjusted from 0° to 25.5° (Temperature offset (0-255) * 0.1) + nominal value temp.
Maximum Charge Temperature, ΔTemp.	0x13		87		MaxT = 61.2°C (74 - (8 * 1.6)) ΔT = 3°C ((7*2) + 16)/10	Maximum charge temperature is 74 - (mt x 1.6)°C (mt = upper nibble). The ΔT step is (dT*2+16)/10°C (dT = lower nibble).
Self-Discharge Rate	0x14		dd		1.5%	This packed field is the two's complement of 52.73/x, where x = %/day is the self-discharge rate desired at room temperature.
Digital Filter	0x15		96		0.3mV	This field is used to set the digital magnitude filter as described in Table 2.
Current Integration Gain <sup>1</sup>	0x16	0x17	40	00	3.2/0.05	This field represents the following: 3.2/sense resistor in ohms. It is used by the bq2092 to scale the measured voltage values on the SR pin in mA and mAh. This register also compensates for variations in the reported sense resistor value.
Full Charge Percentage	0x18		a0		96% = 60h 2's (60h) = a0h	This packed field is the two's complement of the desired value in RM when the bq2092 determines a full charge termination. If RM is below this value, RM is set to this value. If RM is above this value, then RM is not adjusted.
Charge Compensation	0x19		bd		85% = maintenance comp. 95% = fast charge comp.	This packed value is used to set the fast charge and maintenance charge efficiency for nickel-based batteries. The upper nibble adjusts the maintenance charge compensation; the lower nibble adjusts the fast charge compensation. Maintenance, upper nibble = (eff% * 256 - 128)/8 Fast charge, lower nibble = (eff% * 256 - 192)/4
Battery Voltage Offset <sup>1</sup> (V <sub>OFF</sub> )	0x1a		0a		10mV	This value is used to adjust the battery voltage offset according to the following: Voltage () = (V <sub>SB</sub> (mV) + V <sub>OFF</sub> ) * Voltage Gain
Voltage Gain <sup>1</sup>	0x1b	0x1c	09	17	9.09	Voltage gain is packed as two units. For example, (R <sub>4</sub> + R <sub>5</sub> )/R <sub>4</sub> = 9.09 would be stored as: whole number stored in 0x1b (=09h) and the decimal component stored in 0x1c as 256 x 0.09 = 23.
Serial Number	0x1d	0x1e	12	27	10002	This contains the optional pack serial number.

## bq2092

**Table 9. Example Register Contents (Continued)**

Description	EEPROM Address		EEPROM Hex Contents		Example Values	Notes
	Low Byte	High Byte	Low Byte	High Byte		
Hold-off Timer/ $\Delta$ Time	0x1f		07		320 s hold-off 180 s $\Delta$ time	Hold-off time is 20 s * the two's complement of the upper nibble value. $\Delta$ T is 20 s * the two's complement of the lower nibble value.
Charge Cycle Count	0x20	0x21	00	00	0	This field contains the charge cycle count and should be set to zero for a new battery.
Maintenance Charge Current	0x22	0x23	64	00	100mA	This field contains the desired maintenance current after fast charge termination by the bq2092.
Reserved	0x24	0x31				
Design Voltage	0x32	0x33	30	2a	10800mV	This is nominal battery pack voltage.
Specification Information	0x34	0x35	00	00		This is the default value for this register.
Manufacturer Date	0x36	0x37	a1	20	May 1, 1996 = 8353	Packed per the ManufactureDate description, which represents May 1, 1996 in this example.

**Table 10. Example Register Contents (String Data)**

String Description	Address	0x X0	0x X1	0x X2	0x X3	0x X4	0x X5	0x X6	0x X7	0x X8	0x X9	0x Xa	0x Xb-Xf
Reserved	0x38-0x3f	00	00	00	00	00	00	00	00	00	00	00	00-00
Manufacturer's Name	0x40-0x4f	09	42 B	45 E	4e N	43 C	48 H	4d M	41 A	52 R	51 Q	00	00-00
Device Name	0x50-0x5f	08	42 B	51 Q	32 2	30 0	39 9	32 2	41 A	33 3	31 1	31 1	00-00
Chemistry	0x60-0x6f	04	4e N	69 I	4d M	48 H	00	00	00	00	00	00	00-00
Manufacturer's Data	0x70-0x7f	04	44 D	52 R	31 1	35 5	00	00	00	00	00	00	00-00



## Absolute Maximum Ratings

Symbol	Parameter	Minimum	Maximum	Unit	Notes
V <sub>CC</sub>	Relative to V <sub>SS</sub>	-0.3	+7.0	V	
All other pins	Relative to V <sub>SS</sub>	-0.3	+7.0	V	
REF	Relative to V <sub>SS</sub>	-0.3	+8.5	V	Current limited by R1 (see Figure 1)
V <sub>SR</sub>	Relative to V <sub>SS</sub>	-0.3	+7.0	V	Minimum 100Ω series resistor should be used to protect SR in case of a shorted battery (see the bq2092 application note for details).
T <sub>OPR</sub>	Operating temperature	0	+70	°C	Commercial

**Note:** Permanent device damage may occur if **Absolute Maximum Ratings** are exceeded. Functional operation should be limited to the Recommended DC Operating Conditions detailed in this data sheet. Exposure to conditions beyond the operational limits for extended periods of time may affect device reliability.

## DC Voltage Thresholds (T<sub>A</sub> = T<sub>OPR</sub>; V = 3.0 to 5.5V)

Symbol	Parameter	Minimum	Typical	Maximum	Unit	Notes
E <sub>VSB</sub>	Battery voltage error relative to SB	-50mV	-	50mV	V	See note

**Note:** The accuracy of the voltage measurement may be improved by adjusting the battery voltage offset and gain, stored in external EEPROM. For proper operation, V<sub>CC</sub> should be 1.5V greater than V<sub>SB</sub>.

## bq2092

### Recommended DC Operating Conditions (T<sub>A</sub> = T<sub>OPR</sub>)

Symbol	Parameter	Minimum	Typical	Maximum	Unit	Notes
V <sub>CC</sub>	Supply voltage	3.0	4.25	5.5	V	V <sub>CC</sub> excursion from < 2.0V to ≥ 3.0V initializes the unit.
V <sub>REF</sub>	Reference at 25°C	5.7	6.0	6.3	V	I <sub>REF</sub> = 5μA
	Reference at -40°C to +85°C	4.5	-	7.5	V	I <sub>REF</sub> = 5μA
R <sub>REF</sub>	Reference input impedance	2.0	5.0	-	MΩ	V <sub>REF</sub> = 3V
I <sub>CC</sub>	Normal operation	-	90	135	μA	V <sub>CC</sub> = 3.0V
		-	120	180	μA	V <sub>CC</sub> = 4.25V
		-	170	250	μA	V <sub>CC</sub> = 5.5V
V <sub>SB</sub>	Battery input	0	-	V <sub>CC</sub>	V	
R <sub>SBmax</sub>	SB input impedance	10	-	-	MΩ	0 < V <sub>SB</sub> < V <sub>CC</sub>
I <sub>DISP</sub>	$\overline{\text{DISP}}$ input leakage	-	-	5	μA	V <sub>DISP</sub> = V <sub>SS</sub>
I <sub>LVOUT</sub>	V <sub>OUT</sub> output leakage	-0.2	-	0.2	μA	EEPROM off
V <sub>SR</sub>	Sense resistor input	-0.3	-	2.0	V	V <sub>SR</sub> < V <sub>SS</sub> = discharge; V <sub>SR</sub> > V <sub>SS</sub> = charge
R <sub>SR</sub>	SR input impedance	10	-	-	MΩ	-200mV < V <sub>SR</sub> < V <sub>CC</sub>
V <sub>IH</sub>	Logic input high	0.5 * V <sub>CC</sub>	-	V <sub>CC</sub>	V	SCL, SDA
		1.4	-	5.5	V	SCC, SCD
V <sub>IL</sub>	Logic input low	0	-	0.3 * V <sub>CC</sub>	V	SCL, SDA
		-0.5	-	0.6	V	SCC, SCD
V <sub>OL</sub>	Data, clock output low	-	-	0.4	V	I <sub>OL</sub> = 350μA, SDA, SCD
I <sub>OL</sub>	Sink current	100	-	350	μA	V <sub>OL</sub> ≤ 0.4V, SDA, SCD
V <sub>OLSL</sub>	SEG <sub>X</sub> output low, low V <sub>CC</sub>	-	0.1	-	V	V <sub>CC</sub> = 3V, I <sub>OLS</sub> ≤ 1.75mA SEG <sub>1</sub> -SEG <sub>4</sub>
V <sub>OLSH</sub>	SEG <sub>X</sub> output low, high V <sub>CC</sub>	-	0.4	-	V	V <sub>CC</sub> = 5.5V, I <sub>OLS</sub> ≤ 11.0mA SEG <sub>1</sub> -SEG <sub>4</sub>
V <sub>OHVL</sub>	V <sub>OUT</sub> output, low V <sub>CC</sub>	V <sub>CC</sub> - 0.3	-	-	V	V <sub>CC</sub> = 3V, I <sub>VOUT</sub> = -5.25mA
V <sub>OHVH</sub>	V <sub>OUT</sub> output, high V <sub>CC</sub>	V <sub>CC</sub> - 0.6	-	-	V	V <sub>CC</sub> = 5.5V, I <sub>VOUT</sub> = -33.0mA
I <sub>VOUT</sub>	V <sub>OUT</sub> source current	-33	-	-	mA	At V <sub>OHVH</sub> = V <sub>CC</sub> - 0.6V
I <sub>OLS</sub>	SEG <sub>X</sub> sink current	-	-	11.0	mA	At V <sub>OLSH</sub> = 0.4V

**Note:** All voltages relative to V<sub>SS</sub>.

## AC Specifications

Symbol	Parameter	Min	Max	Units	Notes
F <sub>SMB</sub>	SMBus operating frequency	10	100	KHz	
T <sub>BUF</sub>	Bus free time between stop and start condition	4.7		μs	
T <sub>HD:STA</sub>	Hold time after (repeated) start condition	4.0		μs	
T <sub>SU:STA</sub>	Repeated start condition setup time	250		ns	SCD
		4.7		μs	External Memory
T <sub>SU:STO</sub>	Stop condition setup time	4.0		μs	
T <sub>HD:DAT</sub>	Data hold time	1		μs	
T <sub>SU:DAT</sub>	Data setup time	250		ns	
T <sub>EXT1</sub>	Data buffering time addresses		40	ms	0x19, 0x1a, 0x1b
T <sub>EXT2</sub>	String buffering time addresses 0x20-0x23 per character		15	ms	40ms for first character
T <sub>PD</sub>	Data output delay time	300	3500	ns	External memory only. See Note.
T <sub>LOW</sub>	Clock low period	4.7		μs	
T <sub>HIGH</sub>	Clock high period	4.0		μs	
T <sub>F</sub>	Clock/Data fall time		300	ns	
T <sub>R</sub>	Clock/data rise time		1000	ns	

**Note:** The external memory must provide this internal minimum delay time to bridge the undefined region (minimum 300 ns) of the falling edge of SCL to avoid unintended generation of START or STOP conditions.

## Bus Timing Data

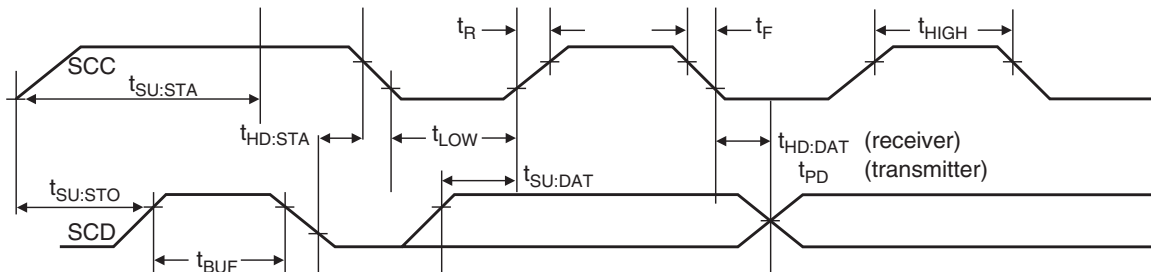

TD209201.eps

# bq2092

## 16-Pin SOIC Narrow (SN)

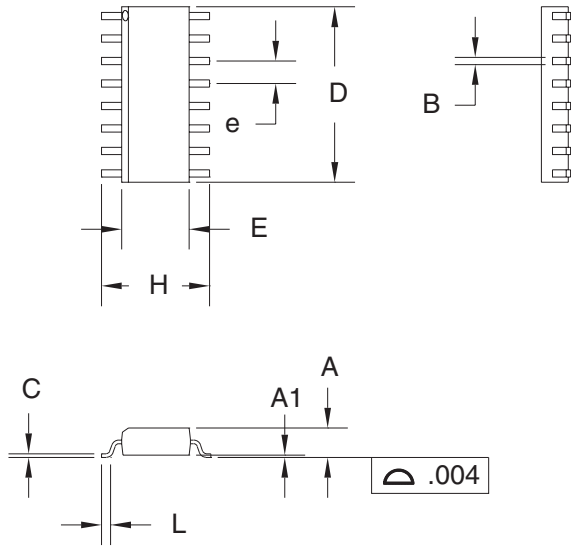

## 16-Pin SN (0.150" SOIC)

Dimension	Inches		Millimeters	
	Min.	Max.	Min.	Max.
A	0.060	0.070	1.52	1.78
A1	0.004	0.010	0.10	0.25
B	0.013	0.020	0.33	0.51
C	0.007	0.010	0.18	0.25
D	0.385	0.400	9.78	10.16
E	0.150	0.160	3.81	4.06
e	0.045	0.055	1.14	1.40
H	0.225	0.245	5.72	6.22
L	0.015	0.035	0.38	0.89

## Data Sheet Revision History

Change No.	Page No.	Description	Nature of Change
1	21	Correction in the Self-Discharge Rate EEPROM Hex contents	Was: f0 Is: df
1	21	Correction in the Self-Discharge Rate example values	Was: 0.15C Is: 1.5%
2	3	Updated application diagram	
2	5	Added VSB should not exceed 2.4V	
2	12	Clarified operation of bits 13 and 14 in BatteryMode()	
2	13	Clarified invalid data indication in RunTimeToEmpty()	
2	13	Clarified invalid data indication in AverageTimeToEmpty()	
2	21	Update formula for voltage divider in Voltage Gain.	

**Note:** Change 1 = Nov. 1997 B changes from April 1997.  
Change 2 = June 1999 C changes from Nov. 1997 B.

## Ordering Information

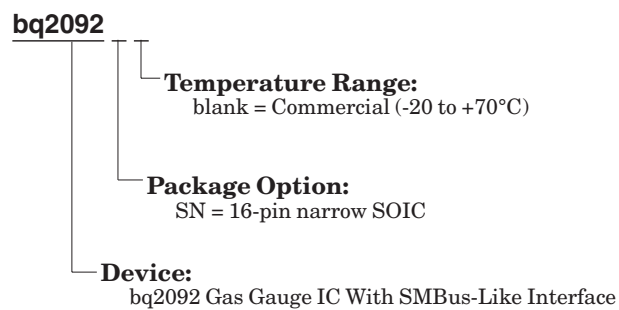

**PACKAGING INFORMATION**

Orderable Device	Status (1)	Package Type	Package Drawing	Pins	Package Qty	Eco Plan (2)	Lead/Ball Finish (6)	MSL Peak Temp (3)	Op Temp (°C)	Device Marking (4/5)	Samples
BQ2092SN-A309	OBSOLETE	SOIC	D	16		TBD	Call TI	Call TI	0 to 70		
BQ2092SN-A309TR	OBSOLETE	SOIC	D	16		TBD	Call TI	Call TI	0 to 70		
BQ2092SN-A311	LIFEBUY	SOIC	D	16	40	Green (RoHS & no Sb/Br)	CU NIPDAU	Level-2-260C-1 YEAR	0 to 70	2092 A311	
BQ2092SN-A311G4	LIFEBUY	SOIC	D	16	40	Green (RoHS & no Sb/Br)	CU NIPDAU	Level-2-260C-1 YEAR	0 to 70	2092 A311	

(1) The marketing status values are defined as follows:

**ACTIVE:** Product device recommended for new designs.

**LIFEBUY:** TI has announced that the device will be discontinued, and a lifetime-buy period is in effect.

**NRND:** Not recommended for new designs. Device is in production to support existing customers, but TI does not recommend using this part in a new design.

**PREVIEW:** Device has been announced but is not in production. Samples may or may not be available.

**OBSOLETE:** TI has discontinued the production of the device.

(2) Eco Plan - The planned eco-friendly classification: Pb-Free (RoHS), Pb-Free (RoHS Exempt), or Green (RoHS & no Sb/Br) - please check <http://www.ti.com/productcontent> for the latest availability information and additional product content details.

**TBD:** The Pb-Free/Green conversion plan has not been defined.

**Pb-Free (RoHS):** TI's terms "Lead-Free" or "Pb-Free" mean semiconductor products that are compatible with the current RoHS requirements for all 6 substances, including the requirement that lead not exceed 0.1% by weight in homogeneous materials. Where designed to be soldered at high temperatures, TI Pb-Free products are suitable for use in specified lead-free processes.

**Pb-Free (RoHS Exempt):** This component has a RoHS exemption for either 1) lead-based flip-chip solder bumps used between the die and package, or 2) lead-based die adhesive used between the die and leadframe. The component is otherwise considered Pb-Free (RoHS compatible) as defined above.

**Green (RoHS & no Sb/Br):** TI defines "Green" to mean Pb-Free (RoHS compatible), and free of Bromine (Br) and Antimony (Sb) based flame retardants (Br or Sb do not exceed 0.1% by weight in homogeneous material)

(3) MSL, Peak Temp. - The Moisture Sensitivity Level rating according to the JEDEC industry standard classifications, and peak solder temperature.

(4) There may be additional marking, which relates to the logo, the lot trace code information, or the environmental category on the device.

(5) Multiple Device Markings will be inside parentheses. Only one Device Marking contained in parentheses and separated by a "~" will appear on a device. If a line is indented then it is a continuation of the previous line and the two combined represent the entire Device Marking for that device.

(6) Lead/Ball Finish - Orderable Devices may have multiple material finish options. Finish options are separated by a vertical ruled line. Lead/Ball Finish values may wrap to two lines if the finish value exceeds the maximum column width.

**Important Information and Disclaimer:** The information provided on this page represents TI's knowledge and belief as of the date that it is provided. TI bases its knowledge and belief on information provided by third parties, and makes no representation or warranty as to the accuracy of such information. Efforts are underway to better integrate information from third parties. TI has taken and

continues to take reasonable steps to provide representative and accurate information but may not have conducted destructive testing or chemical analysis on incoming materials and chemicals. TI and TI suppliers consider certain information to be proprietary, and thus CAS numbers and other limited information may not be available for release.

In no event shall TI's liability arising out of such information exceed the total purchase price of the TI part(s) at issue in this document sold by TI to Customer on an annual basis.



## IMPORTANT NOTICE

Texas Instruments Incorporated and its subsidiaries (TI) reserve the right to make corrections, enhancements, improvements and other changes to its semiconductor products and services per JESD46, latest issue, and to discontinue any product or service per JESD48, latest issue. Buyers should obtain the latest relevant information before placing orders and should verify that such information is current and complete. All semiconductor products (also referred to herein as "components") are sold subject to TI's terms and conditions of sale supplied at the time of order acknowledgment.

TI warrants performance of its components to the specifications applicable at the time of sale, in accordance with the warranty in TI's terms and conditions of sale of semiconductor products. Testing and other quality control techniques are used to the extent TI deems necessary to support this warranty. Except where mandated by applicable law, testing of all parameters of each component is not necessarily performed.

TI assumes no liability for applications assistance or the design of Buyers' products. Buyers are responsible for their products and applications using TI components. To minimize the risks associated with Buyers' products and applications, Buyers should provide adequate design and operating safeguards.

TI does not warrant or represent that any license, either express or implied, is granted under any patent right, copyright, mask work right, or other intellectual property right relating to any combination, machine, or process in which TI components or services are used. Information published by TI regarding third-party products or services does not constitute a license to use such products or services or a warranty or endorsement thereof. Use of such information may require a license from a third party under the patents or other intellectual property of the third party, or a license from TI under the patents or other intellectual property of TI.

Reproduction of significant portions of TI information in TI data books or data sheets is permissible only if reproduction is without alteration and is accompanied by all associated warranties, conditions, limitations, and notices. TI is not responsible or liable for such altered documentation. Information of third parties may be subject to additional restrictions.

Resale of TI components or services with statements different from or beyond the parameters stated by TI for that component or service voids all express and any implied warranties for the associated TI component or service and is an unfair and deceptive business practice. TI is not responsible or liable for any such statements.

Buyer acknowledges and agrees that it is solely responsible for compliance with all legal, regulatory and safety-related requirements concerning its products, and any use of TI components in its applications, notwithstanding any applications-related information or support that may be provided by TI. Buyer represents and agrees that it has all the necessary expertise to create and implement safeguards which anticipate dangerous consequences of failures, monitor failures and their consequences, lessen the likelihood of failures that might cause harm and take appropriate remedial actions. Buyer will fully indemnify TI and its representatives against any damages arising out of the use of any TI components in safety-critical applications.

In some cases, TI components may be promoted specifically to facilitate safety-related applications. With such components, TI's goal is to help enable customers to design and create their own end-product solutions that meet applicable functional safety standards and requirements. Nonetheless, such components are subject to these terms.

No TI components are authorized for use in FDA Class III (or similar life-critical medical equipment) unless authorized officers of the parties have executed a special agreement specifically governing such use.

Only those TI components which TI has specifically designated as military grade or "enhanced plastic" are designed and intended for use in military/aerospace applications or environments. Buyer acknowledges and agrees that any military or aerospace use of TI components which have **not** been so designated is solely at the Buyer's risk, and that Buyer is solely responsible for compliance with all legal and regulatory requirements in connection with such use.

TI has specifically designated certain components as meeting ISO/TS16949 requirements, mainly for automotive use. In any case of use of non-designated products, TI will not be responsible for any failure to meet ISO/TS16949.

### Products

Audio	<a href="http://www.ti.com/audio">www.ti.com/audio</a>
Amplifiers	<a href="http://amplifier.ti.com">amplifier.ti.com</a>
Data Converters	<a href="http://dataconverter.ti.com">dataconverter.ti.com</a>
DLP® Products	<a href="http://www.dlp.com">www.dlp.com</a>
DSP	<a href="http://dsp.ti.com">dsp.ti.com</a>
Clocks and Timers	<a href="http://www.ti.com/clocks">www.ti.com/clocks</a>
Interface	<a href="http://interface.ti.com">interface.ti.com</a>
Logic	<a href="http://logic.ti.com">logic.ti.com</a>
Power Mgmt	<a href="http://power.ti.com">power.ti.com</a>
Microcontrollers	<a href="http://microcontroller.ti.com">microcontroller.ti.com</a>
RFID	<a href="http://www.ti-rfid.com">www.ti-rfid.com</a>
OMAP Applications Processors	<a href="http://www.ti.com/omap">www.ti.com/omap</a>
Wireless Connectivity	<a href="http://www.ti.com/wirelessconnectivity">www.ti.com/wirelessconnectivity</a>

### Applications

Automotive and Transportation	<a href="http://www.ti.com/automotive">www.ti.com/automotive</a>
Communications and Telecom	<a href="http://www.ti.com/communications">www.ti.com/communications</a>
Computers and Peripherals	<a href="http://www.ti.com/computers">www.ti.com/computers</a>
Consumer Electronics	<a href="http://www.ti.com/consumer-apps">www.ti.com/consumer-apps</a>
Energy and Lighting	<a href="http://www.ti.com/energy">www.ti.com/energy</a>
Industrial	<a href="http://www.ti.com/industrial">www.ti.com/industrial</a>
Medical	<a href="http://www.ti.com/medical">www.ti.com/medical</a>
Security	<a href="http://www.ti.com/security">www.ti.com/security</a>
Space, Avionics and Defense	<a href="http://www.ti.com/space-avionics-defense">www.ti.com/space-avionics-defense</a>
Video and Imaging	<a href="http://www.ti.com/video">www.ti.com/video</a>

### TI E2E Community

[e2e.ti.com](http://e2e.ti.com)