

Features

- Extremely low RMS phase jitter (random)
 - <1 ps (typical)
- Wide frequency range
 - 220 MHz to 800 MHz
- High frequency stability
 - ± 10 PPM, ± 15 PPM, ± 20 PPM
 - ± 25 PPM, ± 50 PPM
- Operating voltage
 - 1.8, 2.5 or 3.3 V
 - Other voltages up to 3.63 V (contact SiTime)
- Operating temperature range
 - Industrial, -40 to 85 °C
 - Extended Commercial, -20 to 70 °C
 - Commercial, 0 to 70 °C
- Small footprint
 - 5.0 x 3.2 x 0.75 (L x W x H) mm
 - 7.0 x 5.0 x 0.90 (L x W x H) mm
- Pb-free and RoHS compliant
- For Spread Spectrum option contact SiTime
- Ultra-reliable start up and greater immunity from interference

Benefits

- Ultra fast lead time: 3 to 5 weeks
- No crystal or capacitors required
- Eliminates crystal qualification time
- More than 50% + board saving space
- More cost effective than quartz oscillators, quartz crystals and clock ICs.
- Completely quartz-free

Applications

- Server
- Router
- RAID controller
- Gigabit Ethernet
- 10 Gigabit Ethernet
- Fiber Channel
- SATA / SAS
- PCI-Express
- Fully Buffered DIMM
- System clock
- Networking and computing

Block Diagram

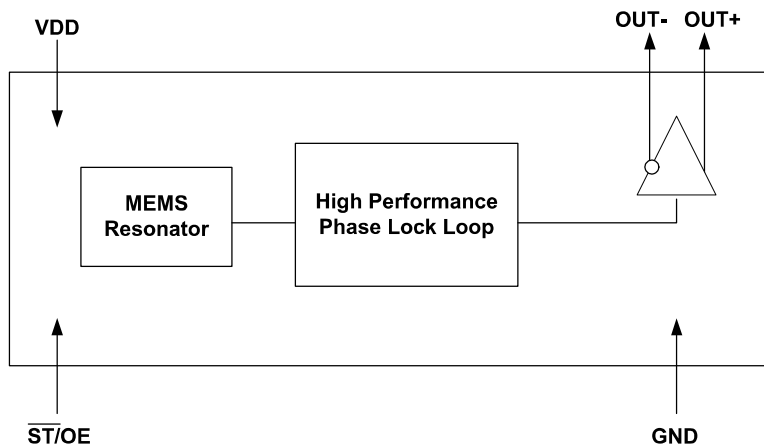

Pinout

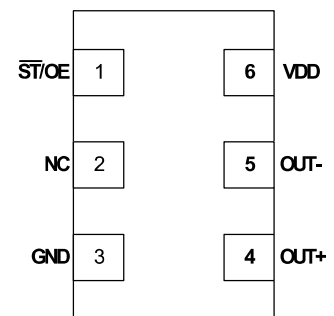

Pin Description

Pin No.	Name		Pin Description
1	ST/OE	Input	Standby or Output Enable pin for OUT+ and OUT-. OE: When High or Open : OUT+ and OUT- = active When Low : OUT+ and OUT- = High Impedance state ST: When High or Open : OUT+ and OUT- = active When Low : OUT+ and OUT- = High Impedance State
2	NC	NA	Do not connect pin, leave it floating.
3	GND	Power	VDD power supply ground. Connect to Ground
4	OUT+	Output	220 to 800 MHz programmable clock output.
5	OUT-	Output	
6	VDD	Power	Power supply

Absolute Maximum Ratings

Attempted operation outside the absolute maximum ratings of the part may cause permanent damage to the part. Actual performance of the IC is only guaranteed within the operational specifications, not at absolute maximum ratings.

Absolute Maximum Table

Parameter	Min.	Max.	Unit
Storage Temperature	-65	150	°C
VDD	-0.5	4	V
Vin	GND - 0.5	VDD + 0.5	V
Theta JA (with copper plane on VDD and GND) 5.0 x 3.2 package 7.0 x 5.0 package when center pad is soldered down 7.0 x 5.0 package when center pad is not soldered down	–	68	°C/W
	–	38	°C/W
	–	90	°C/W
Theta JC (with PCB traces of 0.010 inch to all pins) 5.0 x 3.2 package 7.0 x 5.0 package when center pad is soldered down 7.0 x 5.0 package when center pad is not soldered down	–	45	°C/W
	–	35	°C/W
	–	48	°C/W
Soldering Temperature (follow standard Pb free soldering guidelines)	–	260	°C
Number of Program Writes	–	1	NA
Program Retention over -40 to 125C, Process, VDD (0 to 3.6V)	–	1,000+	years
Human Body Model (JESD22-A114)	2000	–	–
Charged Device Model (JESD22-C101)	750	–	–
Machine Model (JESD22-A115)	200	–	–

Environmental Compliance

Parameter	Condition/Test Method
Mechanical Shock	MIL-STD-883F, Method 2002
Mechanical Vibration	MIL-STD-883F, Method 2007
Temperature Cycle	MIL-STD-883F, Method 1010-65-150°C (1000 cycle)
Solderability	MIL-STD-883F, Method 2003
Moisture Sensitivity Level	MSL1 @ 260°C

DC Electrical Specifications

LVCMOS input, OE or \overline{ST} pin, 3.3V \pm 10% or 2.5V \pm 10% or 1.8V \pm 5%, -40 to 85°C

Symbol	Parameter	Condition	Min.	Typ.	Max.	Unit
V _{IH}	Input High Voltage		70	–	–	%V _{DD}
V _{IL}	Input Low Voltage		–	–	30	%V _{DD}
I _{IH}	Input High Current	OE or ST pin	–	–	10	μA
I _{IL}	Input Low Current	OE or \overline{ST} pin	-10	–	–	μA
T _{pu}	Power Up Time	Time from minimum power supply voltage to the first cycle (Guaranteed no runt pulses)	–	–	10	ms

LVPECL Output, 3.3V \pm 10% or 2.5V \pm 10%, -40 to 85°C

Symbol	Parameter	Condition	Min.	Typ.	Max.	Unit
V _{DD}	Supply Voltage		2.97	3.3	3.63	V
			2.25	2.5	2.75	V
I _{DD}	Supply Current	V _{DD} = 3.3, Excluding Load Termination Current	–	68	74	mA
		V _{DD} = 2.5, Excluding Load Termination Current	–	65	71	mA
V _{OH}	Output High Voltage	50 Ohm termination to V _{DD} - 2.0V See Figure 1, 2.	V _{DD} -1.1	–	V _{DD} -0.7	V
V _{OL}	Output Low Voltage		V _{DD} -2.0	–	V _{DD} -1.4	V
V _{swing}	Pk-Pk Output Voltage Swing		600	800	1000	mV

LVDS Output, 3.3V \pm 10% or 2.5V \pm 10%, -40 to 85°C

Symbol	Parameter	Condition	Min.	Typ.	Max.	Unit
V _{DD}	Supply Voltage		2.97	3.3	3.63	V
			2.25	2.5	2.75	V
I _{DD}	Supply Current	V _{DD} = 3.3, Excluding Load Termination Current	–	73	79	mA
		V _{DD} = 2.5, Excluding Load Termination Current	–	70	76	mA
V _{OD1}	Differential Output Voltage	Swing Mode = Normal Single load termination. See Figure 4.	250	350	450	mV
Δ V _{OD1}	V _{OD} Magnitude Change		–	–	50	mV
V _{OS1}	Offset Voltage		–	1.2	–	V
Δ V _{OS1}	V _{OS} Magnitude Change		–	–	50	mV
V _{OD2}	Differential Output Voltage	Swing Mode = High Single load termination. See Figure 4.	500	700	900	mV
Δ V _{OD2}	V _{OD} Magnitude Change		–	–	50	mV
V _{OS2}	Offset Voltage		–	1.2	–	V
Δ V _{OS2}	V _{OS} Magnitude Change		–	–	50	mV
V _{OD3}	Differential Output Voltage	Swing Mode = High Double load termination. See Figure 5.	250	350	450	mV
Δ V _{OD3}	V _{OD} Magnitude Change		–	–	50	mV
V _{OS3}	Offset Voltage		–	1.2	–	V
Δ V _{OS3}	V _{OS} Magnitude Change		–	–	50	mV

CML Output, 3.3V \pm 10% or 2.5V \pm 10% or 1.8V \pm 5%, -40 to 85°C

Symbol	Parameter	Condition	Min.	Typ.	Max.	Unit	
V _{DD}	Supply Voltage		2.97	3.3	3.63	V	
			2.25	2.5	2.75	V	
			1.71	1.8	1.89	V	
I _{DD}	Supply Current	V _{DD} = 3.3V	Excluding Load Termination Current	–	48	51	mA
		V _{DD} = 2.5V		–	47	50	mA
		V _{DD} = 1.8V		–	38	41	mA

CML Output, 3.3V ±10% or 2.5V ±10% or 1.8V ±5%, -40 to 85°C (continued)

V _{OH1}	Output High Voltage	Swing Mode = Normal Single Load Termination See Figure 6.	V _{DD} -0.1	–	V _{DD}	V
V _{OL1}	Output Low Voltage		V _{DD} -0.55	V _{DD} -0.425	V _{DD} -0.3	V
V _{swing1}	Pk-Pk Output Voltage Swing		300	425	550	mV
V _{OH2}	Output High Voltage	Swing Mode = High Single Load Termination See Figure 6.	V _{DD} -0.1	–	V _{DD}	V
V _{OL2}	Output Low Voltage		V _{DD} -1.1	V _{DD} -0.85	V _{DD} -0.6	V
V _{swing2}	Pk-Pk Output Voltage Swing		600	850	1100	mV
V _{OH3}	Output High Voltage	Swing Mode = High Double Load Termination See Figure 7.	V _{DD} -0.1	–	V _{DD}	V
V _{OL3}	Output Low Voltage		V _{DD} -0.55	V _{DD} -0.425	V _{DD} -0.3	V
V _{swing3}	Pk-Pk Output Voltage Swing		300	425	550	mV

AC Electrical Specifications

LVPECL Output, 3.3V ±10%, -40 to 85°C

Symbol	Parameter	Condition	Min.	Typ.	Max.	Unit	
F _{out}	Output Frequency		220	–	800	MHz	
F _{stab}	Frequency Stability	Inclusive of initial stability, operating temp., rated power supply voltage change, load change	0 to 70°C	-10	–	+10	PPM
			-20 to 70°C	-15	–	+15	PPM
			-40 to 85°C	-20	–	+20	PPM
				-25	–	+25	PPM
			-50	–	+50	PPM	
F _{age}	Aging	First year @ 25°C	–	–	1	PPM	
DC	Duty Cycle	F _{out} = 220 - 460 MHz, 490 - 610 MHz or 750 - 800 MHz	45	–	55	%	
		F _{out} = 460.1 - 489.9 MHz or 610.1- 749.9 MHz	35	–	65	%	
t _R /t _F	Output Rise/Fall Time	20% to 80%	160	260	350	ps	
PH _J	RMS Phase Jitter (random)	F _{out} = 212.5MHz @ BW: 1.875M Hz to10 MHz	–	0.3	0.44	ps	
		F _{out} = 312.5 MHz @ BW: 1.875M Hz to10 MHz	–	0.3	0.33	ps	
		F _{out} = 600 MHz @ BW: 1.875M Hz to10 MHz	–	0.3	0.34	ps	
P _J	RMS Period Jitter	F _{out} = 212.5 MHz	–	1.4	1.8	ps	
		F _{out} = 312.5 MHz	–	1.4	1.8	ps	
		F _{out} = 600 MHz	–	1.5	2.2	ps	
		F _{out} = 800 MHz	–	1.2	1.6	ps	

LVPECL Output, 2.5V ±10%, -40 to 85°C

Symbol	Parameter	Condition		Min.	Typ.	Max.	Unit
F _{out}	Output Frequency			220	–	800	MHz
F _{stab}	Frequency Stability	Inclusive of initial stability, operating temp., rated power supply voltage change, load change	0 to 70°C	-10	–	+10	PPM
			-20 to 70°C	-15	–	+15	PPM
			-40 to 85°C	-20	–	+20	PPM
				-25		+25	PPM
				-50		+50	PPM
F _{age}	Aging	First year @ 25°C		–	–	1	PPM
DC	Duty Cycle	F _{out} = 220 - 460 MHz, 490 - 610 MHz or 750 - 800 MHz		45	–	55	%
		F _{out} = 460.1 - 489.9 MHz or 610.1 - 749.9 MHz		35	–	65	%
t _R /t _F	Output Rise/Fall Time	20% to 80%		160	260	350	ps
PH _J	RMS Phase Jitter (random)	F _{out} = 212.5MHz @ BW: 1.875MHz to10 MHz		–	0.3	0.44	ps
		F _{out} = 312.5 MHz @ BW: 1.875MHz to10 MHz		–	0.3	0.33	ps
		F _{out} = 600 MHz @ BW: 1.875MHz to10 MHz		–	0.3	0.34	ps
P _J	RMS Period Jitter	F _{out} = 212.5 MHz		–	1.4	1.8	ps
		F _{out} = 312.5 MHz		–	1.4	1.8	ps
		F _{out} = 600 MHz		–	1.5	2.2	ps
		F _{out} = 800 MHz		–	1.2	1.6	ps

LVDS Output, 3.3V ±10%, -40 to 85°C

Symbol	Parameter	Condition		Min.	Typ.	Max.	Unit
F _{out}	Output Frequency			220	–	800	MHz
F _{stab}	Frequency Stability	Inclusive of initial stability, operating temp., rated power supply voltage change, load change	0 to 70°C	-10	–	+10	PPM
			-20 to 70°C	-15	–	+15	PPM
			-40 to 85°C	-20	–	+20	PPM
				-25		+25	PPM
				-50		+50	PPM
F _{age}	Aging	First year @ 25°C		–	–	1	PPM
DC	Duty Cycle	F _{out} = 220 - 460 MHz, 490 - 610 MHz or 750 - 800 MHz		45	–	55	%
		F _{out} = 460.1 - 489.9 MHz or 610.1 - 749.9 MHz		35	–	65	%
t _R /t _F	Output Rise/Fall Time	20% to 80%		240	310	420	ps
PH _J	RMS Phase Jitter (random)	F _{out} = 212.5MHz @ BW: 1.875M Hz to10 MHz		–	0.4	0.8	ps
		F _{out} = 312.5 MHz @ BW: 1.875M Hz to10 MHz		–	0.3	0.6	ps
		F _{out} = 600 MHz @ BW: 1.875M Hz to10 MHz		–	0.2	0.4	ps
P _J	RMS Period Jitter	F _{out} = 212.5 MHz		–	1.8	2.5	ps
		F _{out} = 312.5 MHz		–	1.7	2.4	ps
		F _{out} = 600 MHz		–	1.7	2.5	ps
		F _{out} = 800 MHz		–	1.5	2.2	ps

LVDS Output, 2.5V ±10%, -40 to 85°C

Symbol	Parameter	Condition	Min.	Typ.	Max.	Unit	
F _{out}	Output Frequency		220	–	800	MHz	
F _{stab}	Frequency Stability	Inclusive of initial stability, operating temp., rated power supply voltage change, load change	0 to 70°C	-10	–	+10	PPM
			-20 to 70°C	-15	–	+15	PPM
			-40 to 85°C	-20	–	+20	PPM
				-25		+25	PPM
				-50		+50	PPM
F _{age}	Aging	First year @ 25°C	–	–	1	PPM	
DC	Duty Cycle	F _{out} = 220 - 460 MHz, 490 - 610 MHz or 750 - 800 MHz	45	–	55	%	
		F _{out} = 460.1 - 489.9 MHz or 610.1 - 749.9 MHz	35	–	65	%	
t _R /t _F	Output Rise/Fall Time	20% to 80%	240	310	420	ps	
PH _J	RMS Phase Jitter (random)	F _{out} = 212.5MHz @ BW: 1.875MHz to10 MHz	–	0.4	0.8	ps	
		F _{out} = 312.5 MHz @ BW: 1.875MHz to10 MHz	–	0.3	0.6	ps	
		F _{out} = 600 MHz @ BW: 1.875MHz to10 MHz	–	0.2	0.4	ps	
P _J	RMS Period Jitter	F _{out} = 212.5 MHz	–	1.7	2.4	ps	
		F _{out} = 312.5 MHz	–	1.7	2.5	ps	
		F _{out} = 600 MHz	–	1.6	2.1	ps	
		F _{out} = 800 MHz	–	1.4	1.8	ps	

CML Output, 3.3V ±10%, -40 to 85°C

Symbol	Parameter	Condition	Min.	Typ.	Max.	Unit	
F _{out}	Output Frequency		220	–	800	MHz	
F _{stab}	Frequency Stability	Inclusive of initial stability, operating temp., rated power supply voltage change, load change	0 to 70°C	-10	–	+10	PPM
			-20 to 70°C	-15	–	+15	PPM
			-40 to 85°C	-20	–	+20	PPM
				-25		+25	PPM
				-50		+50	PPM
F _{age}	Aging	First year @ 25°C	–	–	1	PPM	
DC	Duty Cycle	F _{out} = 220 - 460 MHz, 490 - 610 MHz or 750 - 800 MHz	45	–	55	%	
		F _{out} = 460.1 - 489.9 MHz or 610.1 - 749.9 MHz	35	–	65	%	
t _R /t _F	Output Rise/Fall Time	20% to 80%	270	350	470	ps	
PH _J	RMS Phase Jitter (random)	F _{out} = 212.5MHz @ BW: 1.875M Hz to10 MHz	–	0.47	0.53	ps	
		F _{out} = 312.5 MHz @ BW: 1.875M Hz to10 MHz	–	0.32	0.42	ps	
		F _{out} = 600 MHz @ BW: 1.875M Hz to10 MHz	–	0.26	0.34	ps	
P _J	RMS Period Jitter	F _{out} = 212.5 MHz	–	1.7	2.1	ps	
		F _{out} = 312.5 MHz	–	1.7	2.1	ps	
		F _{out} = 600 MHz	–	1.7	2.2	ps	
		F _{out} = 800 MHz	–	1.4	1.8	ps	

CML, 2.5V ± 10%, -40 to 85°C

Symbol	Parameter	Condition	Min.	Typ.	Max.	Unit	
F _{out}	Output Frequency		220	–	800	MHz	
F _{stab}	Frequency Stability	Inclusive of initial stability, operating temp., rated power supply voltage change, load change	0 to 70°C	-10	–	+10	PPM
			-20 to 70°C	-15	–	+15	PPM
			-40 to 85°C	-20	–	+20	PPM
				-25		+25	PPM
				-50		+50	PPM
F _{age}	Aging	First year @ 25°C	–	–	1	PPM	
DC	Duty Cycle	F _{out} = 220 - 460 MHz, 490 - 610 MHz or 750 - 800 MHz	45	–	55	%	
		F _{out} = 460.1 - 489.9 MHz or 610.1 - 749.9 MHz	35	–	65	%	
t _R /t _F	Output Rise/Fall Time	20% to 80%	270	350	470	ps	
PH _J	RMS Phase Jitter (random)	F _{out} = 212.5MHz @ BW: 1.875MHz to10 MHz	–	0.47	0.53	ps	
		F _{out} = 312.5 MHz @ BW: 1.875MHz to10 MHz	–	0.32	0.38	ps	
		F _{out} = 600 MHz @ BW: 1.875MHz to10 MHz	–	0.26	0.34	ps	
P _J	RMS Period Jitter	F _{out} = 212.5 MHz	–	1.7	2.1	ps	
		F _{out} = 312.5 MHz	–	1.7	2.1	ps	
		F _{out} = 600 MHz	–	1.7	2.2	ps	
		F _{out} = 800 MHz	–	1.4	1.8	ps	

CML, 1.8V ± 5%, -40 to 85°C

Symbol	Parameter	Condition	Min.	Typ.	Max.	Unit	
F _{out}	Output Frequency		220	–	800	MHz	
F _{stab}	Frequency Stability	Inclusive of initial stability, operating temp., rated power supply voltage change, load change	0 to 70°C	-15	–	+15	PPM
			-20 to 70°C	-20	–	+20	PPM
			-40 to 85°C	-25		+25	PPM
				-50		+50	PPM
F _{age}	Aging	First year @ 25°C	–	–	1	PPM	
DC	Duty Cycle	F _{out} = 220 - 460 MHz, 490 - 610 MHz or 750 - 800 MHz	45	–	55	%	
		F _{out} = 460.1 - 489.9 MHz or 610.1 - 749.9 MHz	35	–	65	%	
t _R /t _F	Output Rise/Fall Time	20% to 80%	270	350	470	ps	
PH _J	RMS Phase Jitter (random)	F _{out} = 212.5MHz @ BW: 1.875MHz to10 MHz	–	0.47	0.53	ps	
		F _{out} = 312.5 MHz @ BW: 1.875MHz to10 MHz	–	0.33	0.42	ps	
		F _{out} = 600 MHz @ BW: 1.875MHz to10 MHz	–	0.26	0.34	ps	
P _J	RMS Period Jitter	F _{out} = 212.5 MHz	–	1.9	2.3	ps	
		F _{out} = 312.5 MHz	–	1.8	2.2	ps	
		F _{out} = 600 MHz	–	1.7	2.3	ps	
		F _{out} = 800 MHz	–	1.6	1.9	ps	

Termination Diagrams

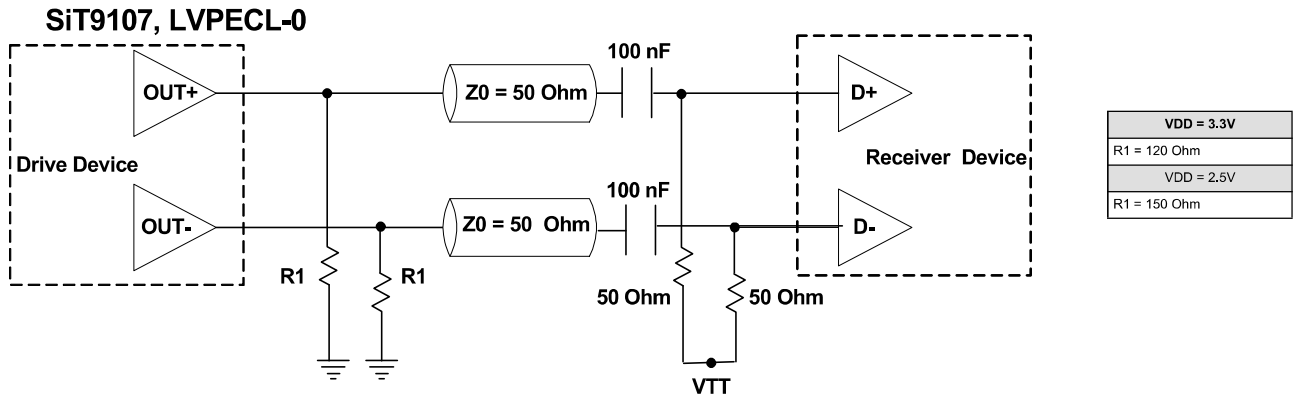

Figure 1. LVPECL AC Coupled Typical Termination

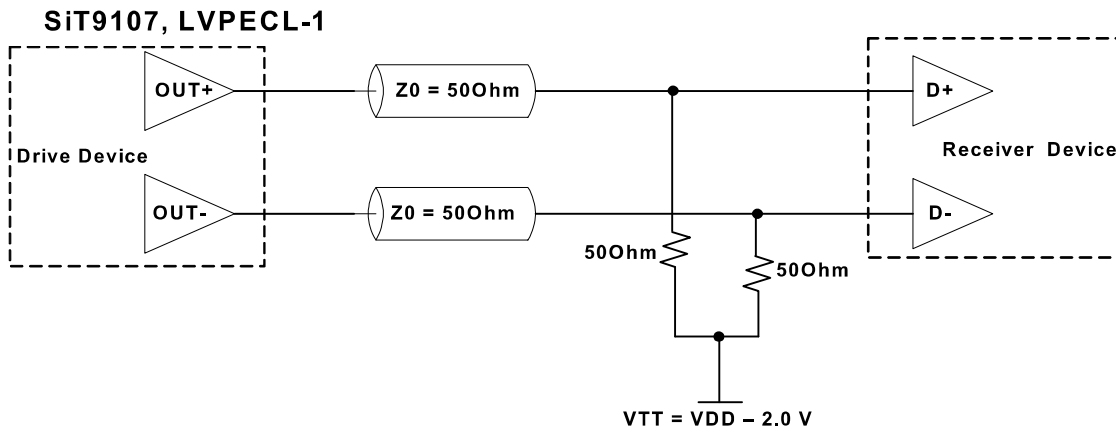

Figure 2. LVPECL DC Coupled Typical Termination with Termination Voltage

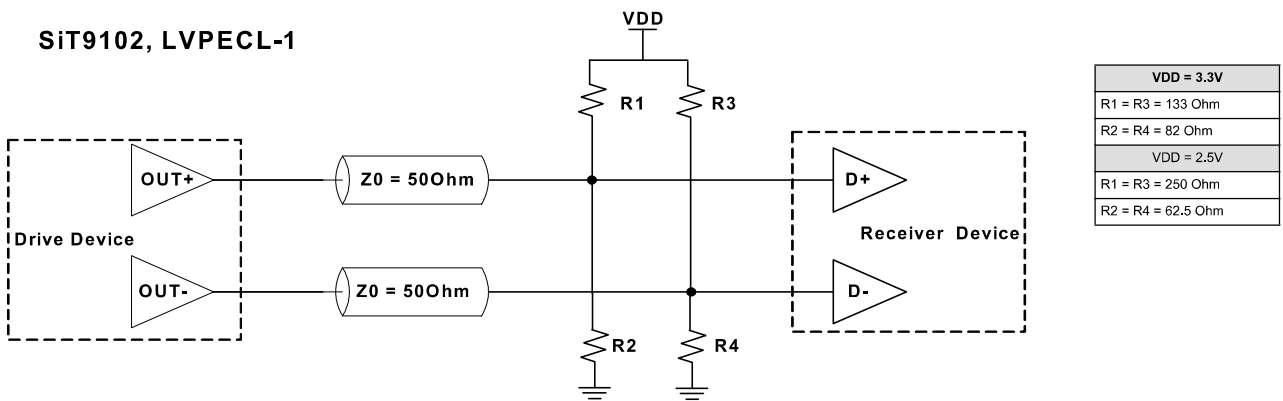

Figure 3. LVPECL DC Coupled Typical Termination without Termination Voltage

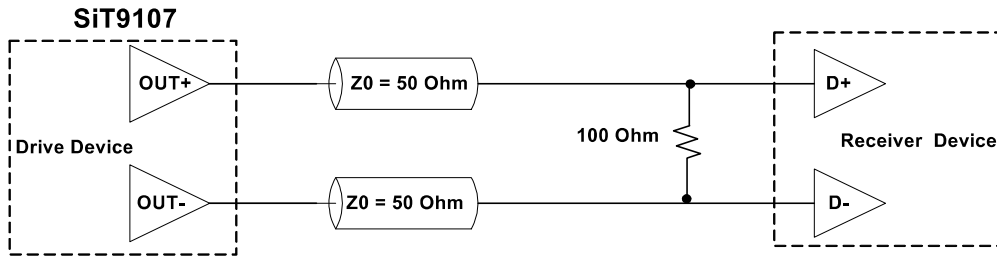
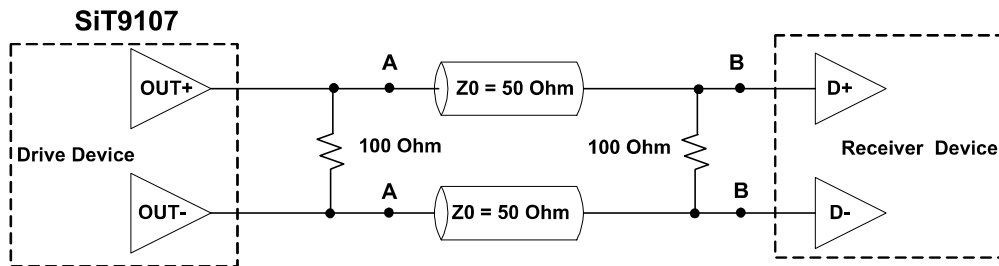

Figure 4. LVDS Single Termination (Load Terminated)



Note: For AC coupled operation, include/insert decoupling caps at points A or B

Figure 5. LVDS Double Termination (Source + Load Terminated)

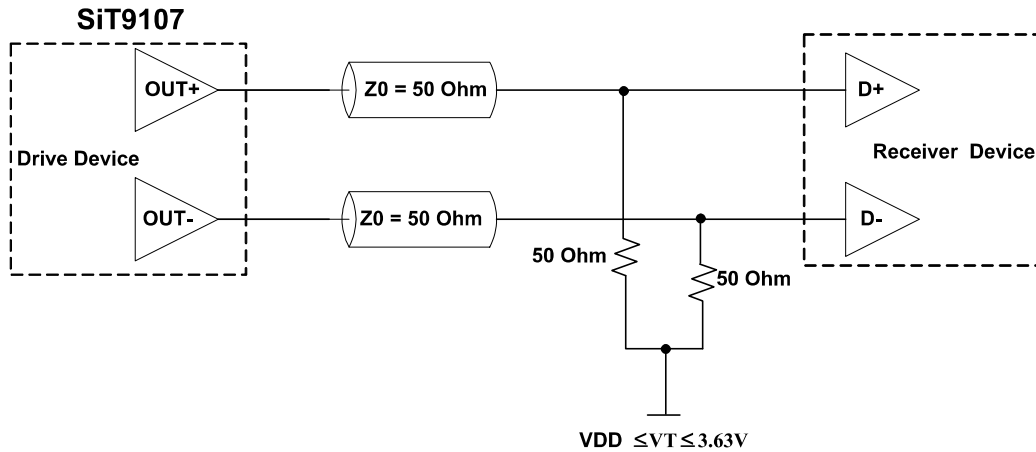
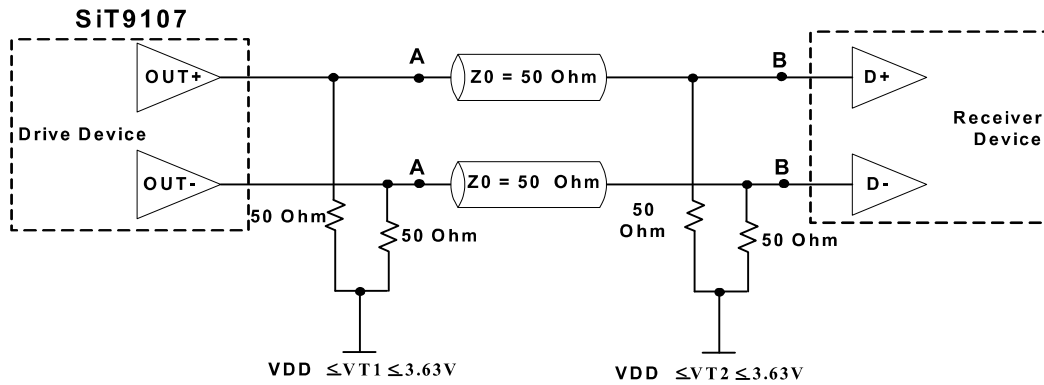

Figure 6. CML Single Load Termination



Notes:

1. For DC-coupled operation, $VT1 = VT2$
2. For AC coupled operation, include/insert decoupling caps at points A or B
2. For AC-coupled operation with capacitors placed at point A, $VT2$ sets the input common mode of Receiver Device and need not to be related to $VT1$

Figure 7. CML Double Load Termination

Ordering Information

The Part No. Guide is for reference only. For real-time customization and exact part number, use the SiTime [Part Number Generator](#).

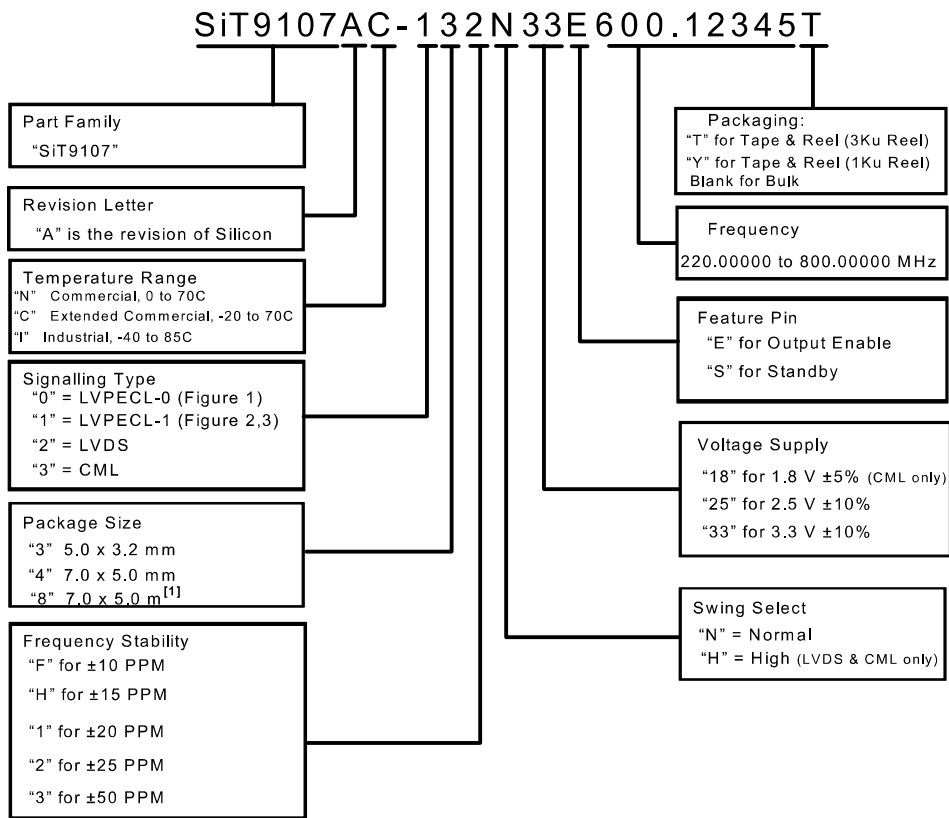

Frequency Stability vs. Temperature Range Options

Frequency Stability (PPM)	Temperature Range	Supply Voltage		
		1.8 V	2.5 V	3.3 V
±10	N (0 to +70°C)	-	✓	✓
	C (-20 to +70°C)	-	-	-
	I (-40 to +85°C)	-	-	-
±15	N (0 to +70°C)	✓	✓	✓
	C (-20 to +70°C)	-	✓	✓
	I (-40 to +85°C)	-	✓	✓
±20	N (0 to +70°C)	✓	✓	✓
	C (-20 to +70°C)	✓	✓	✓
	I (-40 to +85°C)	✓	✓	✓
±25	N (0 to +70°C)	✓	✓	✓
	C (-20 to +70°C)	✓	✓	✓
	I (-40 to +85°C)	✓	✓	✓
±50	N (0 to +70°C)	✓	✓	✓
	C (-20 to +70°C)	✓	✓	✓
	I (-40 to +85°C)	✓	✓	✓

Note:

1. Without Center Pad.

Signaling Type vs. Swing Select Options

Signaling Type	Swing Select	Supply Voltage		
		1.8 V	2.5 V	3.3 V
LVPECL-0	Normal	-	✓	✓
	High	-	-	-
LVPECL-1	Normal	-	✓	✓
	High	-	-	-
LVDS	Normal	-	✓	✓
	High	-	✓	✓
CML	Normal	✓	✓	✓
	High	✓	✓	✓

Package Information ^[2]

Dimension (mm)

5.0 x 3.2 x 0.75mm

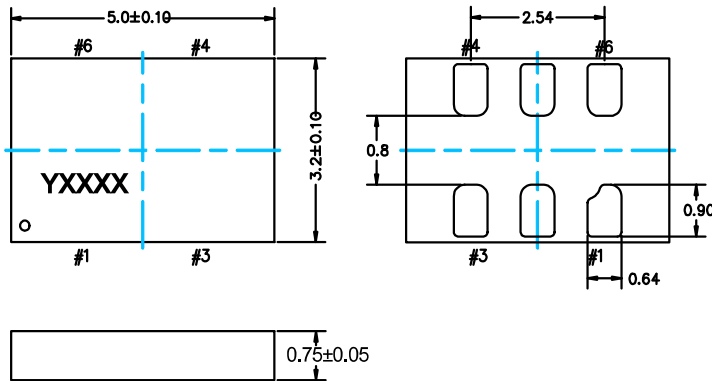

Land Pattern^[3] (recommended) (mm)

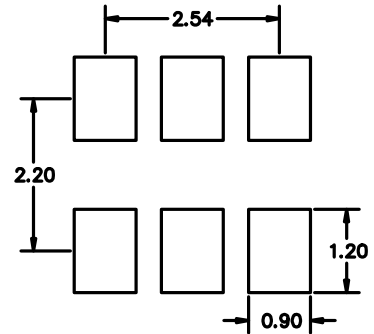

7.0 x 5.0 x 0.90mm ^[4]

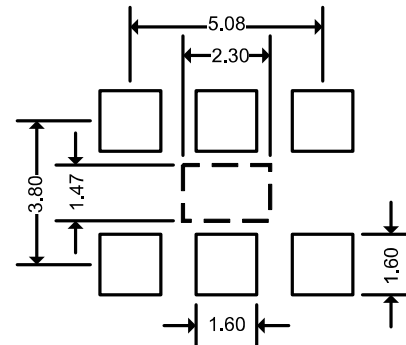
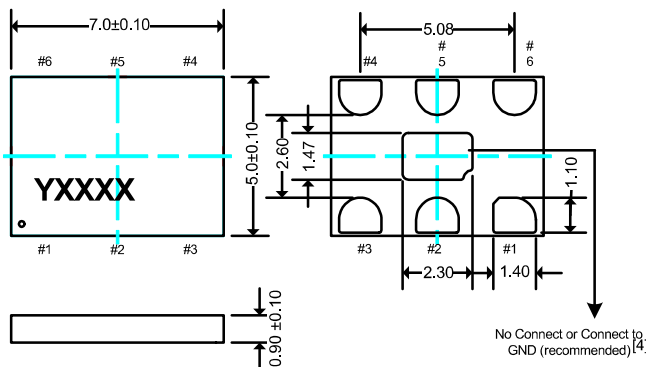

Notes:

- "Y" denotes manufacturing origin and "XXXX" denotes manufacturing lot number. The value of "Y" depend on the assembly location of the device.
- A capacitor of value 0.1µF between VDD and GND is recommended.
- The 7050 package with part number designation "-8" has NO center pad.

© SiTime Corporation 2010. The information contained herein is subject to change at any time without notice. SiTime assumes no responsibility or liability for any loss, damage or defect of a Product which is caused in whole or in part by (i) use of any circuitry other than circuitry embodied in a SiTime product, (ii) misuse or abuse including static discharge, neglect or accident, (iii) unauthorized modification or repairs which have been soldered or altered during assembly and are not capable of being tested by SiTime under its normal test conditions, or (iv) improper installation, storage, handling, warehousing or transportation, or (v) being subjected to unusual physical, thermal, or electrical stress.

Disclaimer: SiTime makes no warranty of any kind, express or implied, with regard to this material, and specifically disclaims any and all express or implied warranties, either in fact or by operation of law, statutory or otherwise, including the implied warranties of merchantability and fitness for use or a particular purpose, and any implied warranty arising from course of dealing or usage of trade, as well as any common-law duties relating to accuracy or lack of negligence, with respect to this material, any SiTime product and any product documentation. Products sold by SiTime are not suitable or intended to be used in a life support application or component, to operate nuclear facilities, or in other mission critical applications where human life may be involved or at stake. All sales are made conditioned upon compliance with the critical uses policy set forth below.

CRITICAL USE EXCLUSION POLICY

BUYER AGREES NOT TO USE SITIME'S PRODUCTS FOR ANY APPLICATION OR IN ANY COMPONENTS USED IN LIFE SUPPORT DEVICES OR TO OPERATE NUCLEAR FACILITIES OR FOR USE IN OTHER MISSION-CRITICAL APPLICATIONS OR COMPONENTS WHERE HUMAN LIFE OR PROPERTY MAY BE AT STAKE.

SiTime owns all rights, title and interest in the intellectual property related to SiTime's products, including any software, firmware, copyright, patent, or trademark. The sale of SiTime products does not convey or imply any license under patent or other rights. SiTime retains the copyright and trademark rights in all documents, catalogs and plans supplied pursuant to or ancillary to the sale of products or services by SiTime. Unless otherwise agreed to in writing by SiTime, any reproduction, modification, translation, compilation, or representation of this material shall be strictly prohibited.