

Features

- Fast charge of nickel cadmium or nickel-metal hydride batteries
- Direct LED output displays charge status
- Fast-charge termination by $-\Delta V$, maximum voltage, maximum temperature, and maximum time
- Internal band-gap voltage reference
- Selectable pulse trickle charge rates
- Low-power mode
- 8-pin 300-mil DIP or 150-mil SOIC

General Description

The bq2002C Fast-Charge IC is a low-cost CMOS battery-charge controller providing reliable charge termination for both NiCd and NiMH battery applications. Controlling a current-limited or constant-current supply allows the bq2002C to be the basis for a cost-effective stand-alone or system-integrated charger. The bq2002C integrates fast charge with pulsed-trickle control in a single IC for charging one or more NiCd or NiMH battery cells.

Fast charge is initiated on application of the charging supply or battery replacement. For safety, fast charge is inhibited if the battery temperature and voltage are outside configured limits.

Fast charge is terminated by any of the following:

- Peak voltage detection (PVD)
- Negative delta voltage ($-\Delta V$)
- Maximum voltage
- Maximum temperature
- Maximum time

After fast charge, the bq2002C pulse-trickles the battery per the pre-configured limits. Fast charge may be inhibited using the INH pin. The bq2002C may also be placed in low-standby-power mode to reduce system power consumption.

Pin Connections

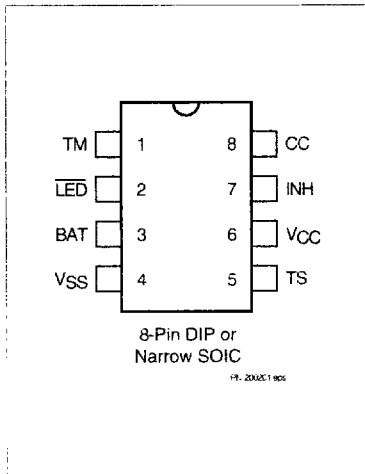

Pin Names

| | | | |
|-------------------------|-------------------------|----------|-------------------------|
| TM | Timer mode select input | TS | Temperature sense input |
| $\overline{\text{LED}}$ | Charging status output | V_{CC} | 5.0V \pm 20% power |
| BAT | Battery voltage input | INH | Charge inhibit input |
| V_{SS} | System ground | CC | Charge control output |

Pin Descriptions

| | |
|------------|--|
| TM | Timer mode input A three-level input that controls the settings for the fast charge safety timer, voltage termination mode, pulse-trickle, and voltage hold-off time. |
| LED | Charging output status Open-drain output that indicates the charging status. |
| BAT | Battery input voltage The battery voltage sense input. The input to this pin is created by a high-impedance resistor divider network connected between the positive and negative terminals of the battery. |
| VSS | System ground |
| TS | Temperature sense input Input for an external battery temperature monitoring thermistor. |
| VCC | VCC supply input 5.0V ±20% power input. |
| INH | Charge inhibit input When high, INH suspends the fast charge in progress. When returned low, the IC resumes operation at the point where initially suspended. |

CC **Charge control output**

An open-drain output used to control the charging current to the battery. CC switching to high impedance (Z) enables charging current to flow, and low to inhibit charging current. CC is modulated to provide pulse trickle.

Functional Description

Figure 3 shows a state diagram and Figure 4 shows a block diagram of the bq2002C.

Battery Voltage and Temperature Measurements

Battery voltage and temperature are monitored for maximum allowable values. The voltage presented on the battery sense input, BAT, should represent a single-cell potential for the battery under charge. A resistor-divider ratio of

$$\frac{RB1}{RB2} = N - 1$$

is recommended to maintain the battery voltage within the valid range, where N is the number of cells, RB1 is the resistor connected to the positive battery terminal, and RB2 is the resistor connected to the negative battery terminal. See Figure 1.

Note: This resistor-divider network input impedance to end-to-end should be at least 200kΩ and less than 1 MΩ.

A ground-referenced negative temperature coefficient thermistor placed near the battery may be used as a low-cost temperature-to-voltage transducer. The temperature sense voltage input at TS is developed using a resistor-thermistor network between VCC and VSS. See Figure 1.

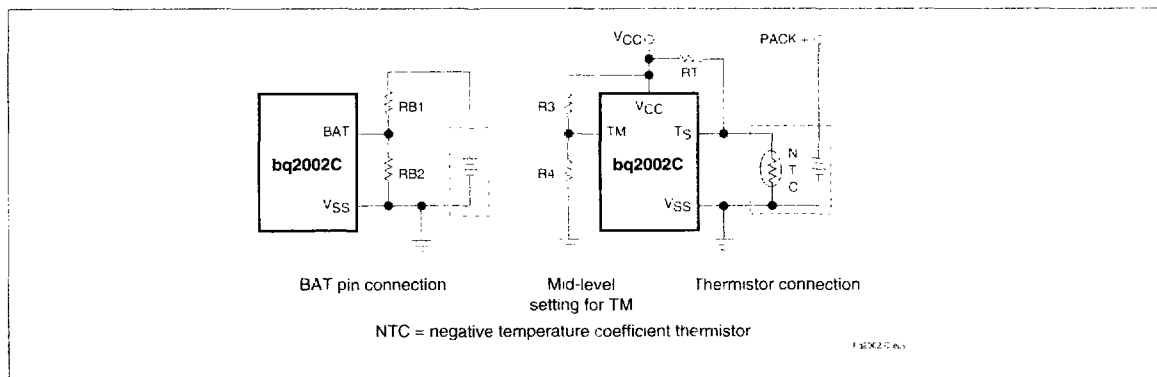

Figure 1. Voltage and Temperature Monitoring and TM Pin Configuration

Starting A Charge Cycle

Either of two events starts a charge cycle (see Figure 2):

1. Application of power to V_{CC} or
2. Voltage at the BAT pin falling through the maximum cell voltage V_{MCV} where

$$V_{MCV} = 2V \pm 5\%$$

If the battery is within the configured temperature and voltage limits, the IC begins fast charge. The valid battery voltage range is $V_{LBAT} < V_{BAT} < V_{MCV}$, where

$$V_{LBAT} = 0.175 * V_{CC} \pm 20\%$$

The valid temperature range is $V_{TS} > V_{HTF}$ where

$$V_{HTF} = 0.6 * V_{CC} \pm 5\%$$

If $V_{BAT} \leq V_{LBAT}$ or $V_{TS} \leq V_{HTF}$, the IC enters the charge-pending state. In this state pulse trickle charge is applied to the battery and the LED flashes until the voltage and temperature come into the allowed fast charge range or V_{BAT} rises above V_{MCV} . Anytime $V_{BAT} \geq V_{MCV}$, the IC enters the Charge Complete/Battery Absent state. In this state the LED is off and trickle charge is applied to the battery until the next new charge cycle begins.

Fast charge continues until termination by one or more of the five possible termination conditions:

- Peak voltage detection (PVD)
- Negative delta voltage ($-\Delta V$)
- Maximum voltage
- Maximum temperature
- Maximum time

PVD and $-\Delta V$ Termination

There are two modes for voltage termination, depending on the state of TM. For $-\Delta V$ (TM = high), if V_{BAT} is lower than any previously measured value by 12mV $\pm 3mV$, fast charge is terminated. For PVD (TM = low or mid), a decrease of 2.5mV $\pm 2.5mV$ terminates fast charge. The PVD and $-\Delta V$ tests are valid in the range $1V < V_{BAT} < 2V$.

Synchronized Voltage Sampling

Voltage sampling at the BAT pin for PVD and $-\Delta V$ termination may be synchronized to an external stimulus using the INH input. Low-high-low input pulses between 100ns and 3.5ms in width must be applied at the INH pin with a frequency greater than the "maximum synchronized sampling period" set by the state of the TM pin as shown in Table 1. Voltage is sampled on the falling edge of such pulses. If the time between pulses is greater than the synchronizing period, voltage sampling "free-runs" at once every 17 seconds. A sample is taken by averaging together voltage measurements taken 57 μs apart. The IC takes 32 measurements in PVD mode and 16 measurements in $-\Delta V$ mode. The resulting sample periods (9.17 and 18.18ms, respectively) filter out harmonics centered around 55 and 109Hz. This technique minimizes the effect of any AC line ripple that may feed through the power supply from either 50 or 60Hz AC sources. If the INH input remains high for more than 12ms, the voltage sample history kept by the IC and used for PVD and $-\Delta V$ termination decisions is erased and a new history is started. Such a reset is required when transitioning from free-running to synchronized voltage sampling. The response of the IC to pulses less than 100ns in width or between 3.5ms and 12ms is indeterminate. The tolerance on all timing is $\pm 12\%$.

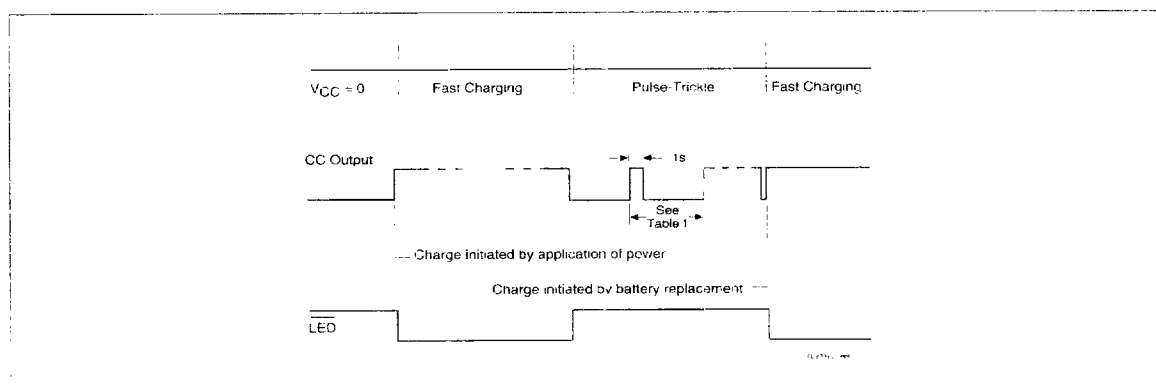

Figure 2. Charge Cycle Phases

Voltage Termination Hold-off

A hold-off period occurs at the start of fast charging. During the hold-off time, the PVD and $-\Delta V$ terminations are disabled. This avoids premature termination on the voltage spikes sometimes produced by older batteries when fast-charge current is first applied. Maximum voltage and temperature terminations are not affected by the hold-off period.

Maximum Voltage, Temperature, and Time

Any time the voltage on the BAT pin exceeds the maximum cell voltage, V_{MCV} , fast charge is terminated.

Maximum temperature termination occurs anytime the voltage on the TS pin falls below the temperature cut-off threshold V_{TCO} , where

$$V_{TCO} = 0.5 * V_{CC} \pm 5\%$$

Maximum charge time is configured using the TM pin. Time settings are available for corresponding charge rates of C/2, 1C, and 2C. Maximum time-out termination is enforced on the fast-charge phase, then reset, and enforced again on the top-off phase, if selected. There is no time limit on the trickle-charge phase.

Pulse-Trickle Charge

Pulse-trickle is used to compensate for self-discharge while the battery is idle in the charger. The battery is pulse-trickle charged by driving the CC pin active once per second for the period specified in Table 1. This results in a trickle rate of C/32.

TM Pin

The TM pin is a three-level pin used to select the charge timer, top-off, voltage termination mode, trickle

rate, and voltage hold-off period options. Table 1 describes the states selected by the TM pin. The mid-level selection input is developed by a resistor divider between V_{CC} and ground that fixes the voltage on TM at $V_{CC}/2 \pm 0.5V$. See Figure 2.

Charge Status Indication

A fast charge in progress is uniquely indicated when the \overline{LED} pin goes low. In the charge pending state, the \overline{LED} pin is driven low for 500ms, then to high-Z for 500ms. The \overline{LED} pin is driven to the high-Z state for all other conditions. Figure 3 outlines the state of the \overline{LED} pin during charge.

Charge Inhibit

Fast charge and top-off may be inhibited by using the INH pin. When high, INH suspends all fast charge and top-off activity and the internal charge timer. INH freezes the current state of \overline{LED} until inhibit is removed. Temperature monitoring is not affected by the INH pin. During charge inhibit, the bq2002C continues to pulse-trickle charge the battery per the TM selection. When INH returns low, charge control and the charge timer resume from the point where INH became active.

Low-Power Mode

The IC enters a low-power state when V_{BAT} is driven above the power-down threshold (V_{PD}) where

$$V_{PD} = V_{CC} - (1V \pm 0.5V)$$

Both the CC pin and the \overline{LED} pin are driven to the high-Z state. The operating current is reduced to less than 1 μ A in this mode. When V_{BAT} returns to a value below V_{PD} , the IC pulse-trickle charges until the next new charge cycle begins.

Table 1. Fast-Charge Safety Time/Hold-Off Table

| Corresponding Fast-Charge Rate | TM | Termination | Typical Fast-Charge Time Limits (minutes) | Typical PVD and $-\Delta V$ Hold-Off Time (seconds) | Pulse-Trickle Rate | Pulse-Trickle Pulse Width (ms) | Maximum Synchronized Sampling Period (seconds) |
|--------------------------------|------|-------------|---|---|--------------------|--------------------------------|--|
| C/2 | Mid | PVD | 160 | 300 | C/32 | 73 | 18.7 |
| 1C | Low | PVD | 80 | 150 | C/32 | 37 | 18.7 |
| 2C | High | $-\Delta V$ | 40 | 75 | C/32 | 18 | 9.4 |

Notes: Typical conditions = 25°C, $V_{CC} = 5.0V$
 Mid = $0.5 * V_{CC} \pm 0.5V$
 Tolerance on all timing is $\pm 12\%$.

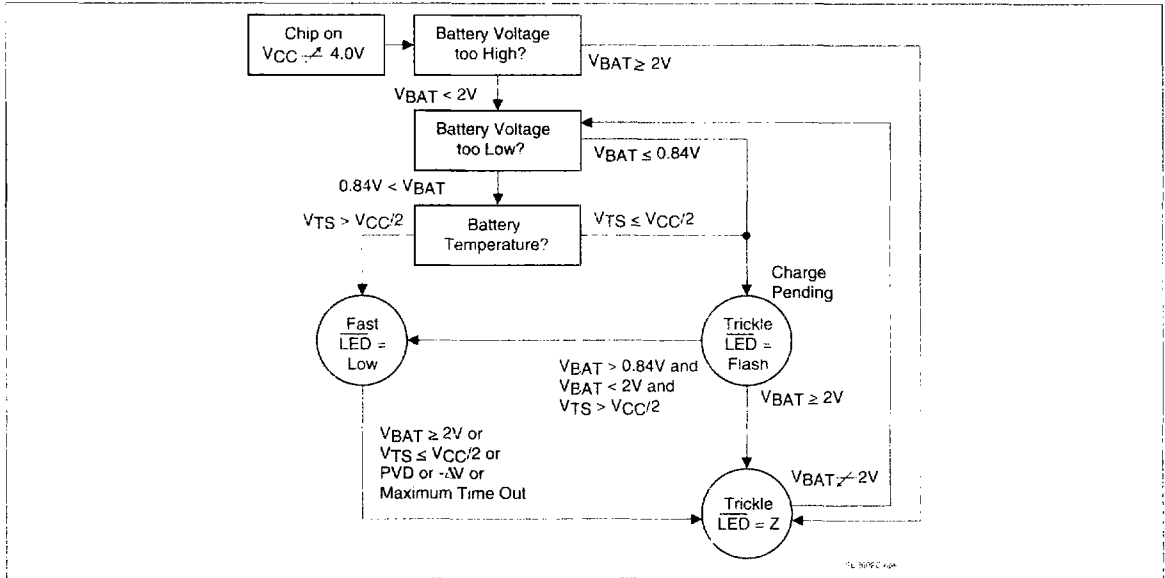

Figure 3. State Diagram

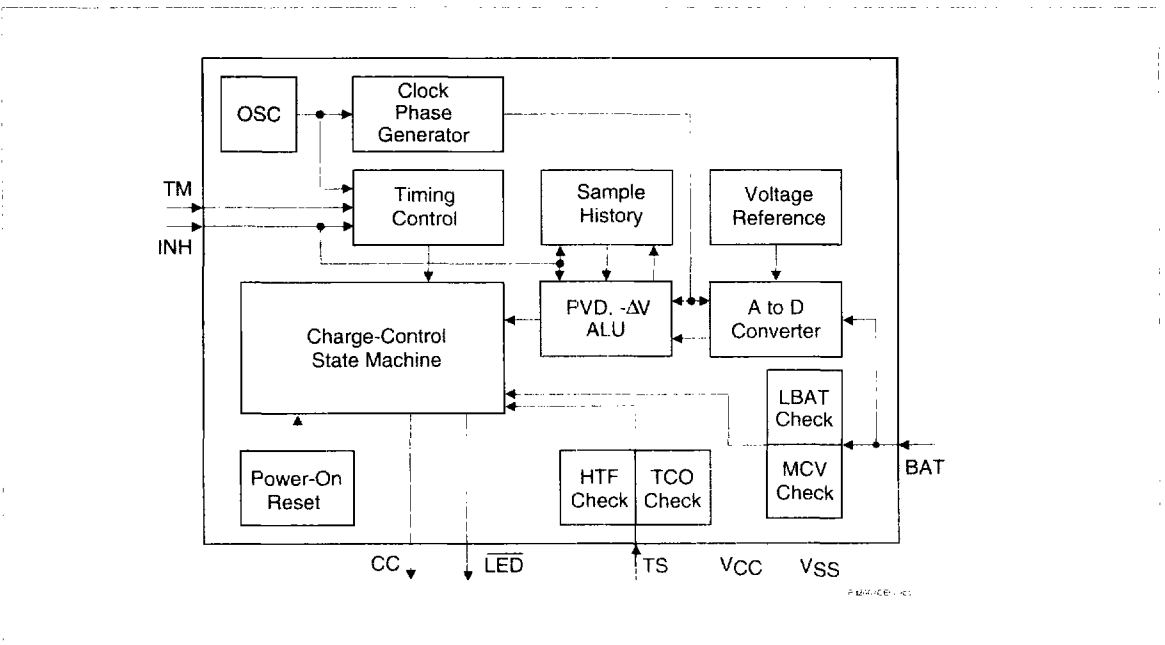

Figure 4. Block Diagram

Absolute Maximum Ratings

| Symbol | Parameter | Minimum | Maximum | Unit | Notes |
|---------------------|---|---------|---------|------|-------------|
| V _{CC} | V _{CC} relative to V _{SS} | -0.3 | +7.0 | V | |
| V _T | DC voltage applied on any pin excluding V _{CC} relative to V _{SS} | -0.3 | +7.0 | V | |
| T _{OPR} | Operating ambient temperature | 0 | +70 | °C | Commercial |
| T _{STG} | Storage temperature | -40 | +85 | °C | |
| T _{SOLDER} | Soldering temperature | - | +260 | °C | 10 sec max. |
| T _{BIAS} | Temperature under bias | -40 | +85 | °C | |

Note: Permanent device damage may occur if **Absolute Maximum Ratings** are exceeded. Functional operation should be limited to the Recommended DC Operating Conditions detailed in this data sheet. Exposure to conditions beyond the operational limits for extended periods of time may affect device reliability.

DC Thresholds (T_A = 0 to 70°C; V_{CC} ±20%)

| Symbol | Parameter | Rating | Tolerance | Unit | Notes |
|-------------------|------------------------------------|-------------------------|-----------|------|---|
| V _{TCO} | Temperature cutoff | 0.5 * V _{CC} | ±5% | V | V _{TS} ≤ V _{TCO} inhibits/terminates fast charge |
| V _{HTF} | High-temperature fault | 0.6 * V _{CC} | ±5% | V | V _{TS} ≤ V _{HTF} inhibits fast charge start |
| V _{MCV} | Maximum cell voltage | 2 | ±5% | V | V _{BAT} ≥ V _{MCV} inhibits/terminates fast charge |
| V _{LBAT} | Minimum cell voltage | 0.175 * V _{CC} | ±20% | V | V _{BAT} ≤ V _{LBAT} inhibits fast charge |
| -ΔV | BAT input change for -ΔV detection | -12 | ±3 | mV | |
| PVD | BAT input change for PVD detection | -2.5 | ±2.5 | mV | |

Recommended DC Operating Conditions ($T_A = 0$ to 70°C)

| Symbol | Condition | Minimum | Typical | Maximum | Unit | Notes |
|------------------|-----------------------------------|--------------------------|---------|--------------------------|------|---|
| V _{CC} | Supply voltage | 4.0 | 5.0 | 6.0 | V | |
| V _{DET} | -ΔV, PVD detect voltage | 1 | - | 2 | V | |
| V _{BAT} | Battery input | 0 | - | V _{CC} | V | |
| V _{TS} | Thermistor input | 0.5 | - | V _{CC} | V | V _{TS} < 0.5V prohibited |
| V _{IH} | Logic input high | 0.5 | - | - | V | INH |
| | Logic input high | V _{CC} - 0.5 | - | - | V | TM |
| V _{IM} | Logic input mid | $\frac{V_{CC}}{2} - 0.5$ | - | $\frac{V_{CC}}{2} + 0.5$ | V | TM |
| V _{IL} | Logic input low | - | - | 0.1 | V | INH |
| | Logic input low | - | - | 0.5 | V | TM |
| V _{OL} | Logic output low | - | - | 0.8 | V | $\overline{\text{LED}}$, CC, I _{OL} = 10mA |
| V _{PD} | Power down | V _{CC} - 1.5 | - | V _{CC} - 0.5 | V | V _{BAT} ≥ V _{PD} max. powers down bq2002C; V _{BAT} < V _{PD} min. = normal operation. |
| I _{CC} | Supply current | - | - | 500 | μA | Outputs unloaded, V _{CC} = 5.1V |
| I _{SB} | Standby current | - | - | 1 | μA | V _{CC} = 5.1V, V _{BAT} = V _{PD} |
| I _{OL} | $\overline{\text{LED}}$, CC sink | 10 | - | - | mA | @V _{OL} = V _{SS} + 0.8V |
| I _L | Input leakage | - | - | ±1 | μA | INH, CC, V = V _{SS} to V _{CC} |
| I _{OZ} | Output leakage in high-Z state | -5 | - | - | μA | $\overline{\text{LED}}$, CC |

Note: All voltages relative to V_{SS}.

bq2002C

Impedance

| Symbol | Parameter | Minimum | Typical | Maximum | Unit |
|------------------|-------------------------|---------|---------|---------|------|
| R _{BAT} | Battery input impedance | 50 | - | - | MΩ |
| R _{TS} | TS input impedance | 50 | - | - | MΩ |

Timing (T_A = 0 to +70°C; V_{CC} ±10%)

| Symbol | Parameter | Minimum | Typical | Maximum | Unit | Notes |
|------------------|---------------------|---------|---------|---------|------|-------|
| d _{FCV} | Time base variation | -12 | - | 12 | % | |

Note: Typical is at T_A = 25°C, V_{CC} = 5.0V.

Data Sheet Revision History

| Change No. | Page No. | Description |
|------------|----------|---|
| 1 | All | Revised format and outline of this data sheet |

Note: Change 1 = Sept. 1997 B changes from Dec. 1995.

Ordering Information

bq2002C

Package Option:

PN = 8-pin plastic DIP
SN = 8-pin narrow SOIC

Device:

bq2002C Fast-Charge IC