

National Semiconductor is now part of  
Texas Instruments.

Search <http://www.ti.com/> for the latest technical  
information and details on our current products and services.

# LM3722/LM3723/LM3724

## 5-Pin Microprocessor Reset Circuits

### General Description

The LM3722/LM3723/LM3724 microprocessor supervisory circuits monitor the power supplies in microprocessor and digital systems. They provide a reset to the microprocessor during power-up, power-down, brown-out conditions, and manual reset.

The LM3722/LM3723/LM3724 asserts a reset signal whenever the supply decreases below the factory-programmed reset threshold. Reset will be asserted for at least 100ms even after  $V_{CC}$  rises above the reset threshold.

The LM3722 has an active-low  $\overline{\text{RESET}}$  push-pull output. The LM3723 has an active-high  $\text{RESET}$  push-pull output. The LM3724 has an active-low open-drain  $\overline{\text{RESET}}$  output.

Three standard reset voltage options are available, suitable for monitoring 5V, 3.3V, and 2.5V supply voltages. Additional reset voltages are also available; contact National Semiconductor for details.

With a low supply current of only 6 $\mu\text{A}$ , the LM3722/LM3723/LM3724 are ideal for use in portable equipment. The LM3722/LM3723/LM3724 are available in the 5-pin SOT23 package.

### Features

- Precise monitoring of 2.5V, 3.3V, and 5V supply voltages
- Fully specified over temperature
  - Industrial:  $-40^{\circ}\text{C}$  to  $+85^{\circ}\text{C}$
  - Extended:  $-40^{\circ}\text{C}$  to  $+125^{\circ}\text{C}$
- 100 ms minimum Power-On Reset pulse width, 190 ms typical:
  - Active-Low  $\overline{\text{RESET}}$  Output (LM3722)
  - Active-High  $\text{RESET}$  Output (LM3723)
  - Active-Low  $\overline{\text{RESET}}$  Open Drain Output (LM3724)
- Guaranteed  $\overline{\text{RESET}}$  Output valid for  $V_{CC} \geq 1\text{V}$
- Low Supply Current, 6 $\mu\text{A}$  typical
- Power supply transient immunity
- Compatible with MAX811/812 applications

### Applications

- Microprocessor Systems
- Computers
- Controllers
- Intelligent Instruments
- Portable/Battery-Powered Equipment

### Typical Application Circuit

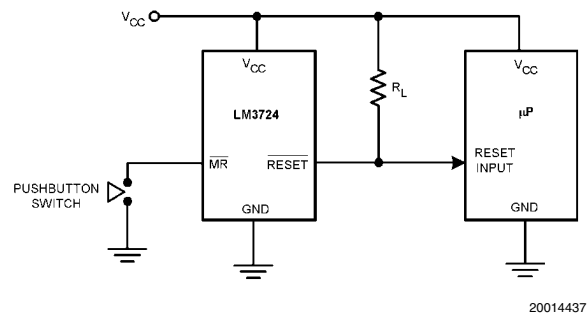
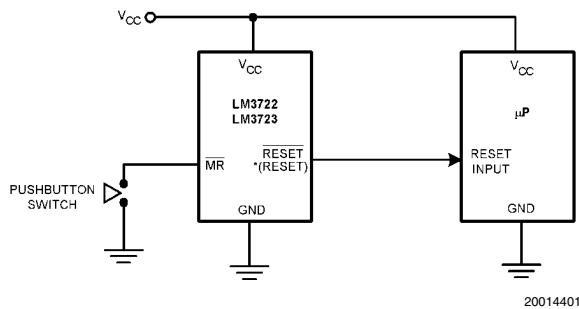

### Connection Diagram

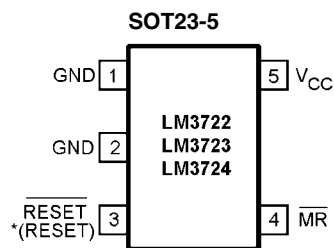

\*( ) are for LM3723

## Ordering Information

### Industrial Temperature Range (–40°C to +85°C):

Reset Threshold (V)	LM3722 Supplied as 1000 units, tape & reel	LM3722 Supplied as 3000 units, tape & reel	Package Top Mark	Package Type	NSC Package
4.63	LM3722IM5-4.63	LM3722IM5X-4.63	R43B	SOT23-5	MF05A
3.08	LM3722IM5-3.08	LM3722IM5X-3.08	R41B		
2.32	LM3722IM5-2.32	LM3722IM5X-2.32	R34B		

Reset Threshold (V)	LM3723 Supplied as 1000 units, tape & reel	LM3723 Supplied as 3000 units, tape & reel	Package Top Mark	Package Type	NSC Package
4.63	LM3723IM5-4.63	LM3723IM5X-4.63	R13B	SOT23-5	MF05A
3.08	LM3723IM5-3.08	LM3723IM5X-3.08	R11B		
2.32	LM3723IM5-2.32	LM3723IM5X-2.32	R46B		

Reset Threshold (V)	LM3724 Supplied as 1000 units, tape & reel	LM3724 Supplied as 3000 units, tape & reel	Package Top Mark	Package Type	NSC Package
4.63	LM3724IM5-4.63	LM3724IM5X-4.63	R55B	SOT23-5	MF05A
3.08	LM3724IM5-3.08	LM3724IM5X-3.08	R53B		
2.32	LM3724IM5-2.32	LM3724IM5X-2.32	R50B		

### Extended Temperature Range (–40°C to +125°C):

Reset Threshold (V)	LM3722 Supplied as 1000 units, tape & reel	LM3722 Supplied as 3000 units, tape & reel	Package Top Mark	Package Type	NSC Package
4.63	LM3722EM5-4.63	LM3722EM5X-4.63	R56B	SOT23-5	MF05A
3.08	LM3722EM5-3.08	LM3722EM5X-3.08	R57B		
2.32	LM3722EM5-2.32	LM3722EM5X-2.32	R58B		

Reset Threshold (V)	LM3723 Supplied as 1000 units, tape & reel	LM3723 Supplied as 3000 units, tape & reel	Package Top Mark	Package Type	NSC Package
4.63	LM3723EM5-4.63	LM3723EM5X-4.63	R59B	SOT23-5	MF05A
3.08	LM3723EM5-3.08	LM3723EM5X-3.08	R60		
2.32	LM3723EM5-2.32	LM3723EM5X-2.32	R61B		

Reset Threshold (V)	LM3724 Supplied as 1000 units, tape & reel	LM3724 Supplied as 3000 units, tape & reel	Package Top Mark	Package Type	NSC Package
4.63	LM3724EM5-4.63	LM3724EM5X-4.63	R62B	SOT23-5	MF05A
3.08	LM3724EM5-3.08	LM3724EM5X-3.08	R63B		
2.32	LM3724EM5-2.32	LM3724EM5X-2.32	R64B		

Custom voltages and improved accuracies are available, subject to minimum orders. Contact your local National Semiconductor Sales Office for information.

## Pin Descriptions

PIN	NAME	FUNCTION
1	GND	Ground reference
2	GND	Ground reference, device substrate, connect to ground.
3	$\overline{\text{RESET}}$ LM3722/LM3724	Active-low output. $\overline{\text{RESET}}$ remains low while $V_{\text{CC}}$ is below the reset threshold voltage, and for 190 ms after $V_{\text{CC}}$ rises above the reset threshold.
	RESET LM3723	Active-high output. RESET remains high while $V_{\text{CC}}$ is below the reset threshold, and for 190 ms after $V_{\text{CC}}$ rises above the reset threshold.
4	$\overline{\text{MR}}$	Active-low input. Reset is asserted whenever this pin is pulled low and remains asserted for 190 ms after the $\overline{\text{MR}}$ pin goes high. May be left open.
5	$V_{\text{CC}}$	Supply Voltage (+5V, +3.3V, or +2.5V, nominal)

## Block Diagram

LM3722/LM3723/LM3724 Block Diagram

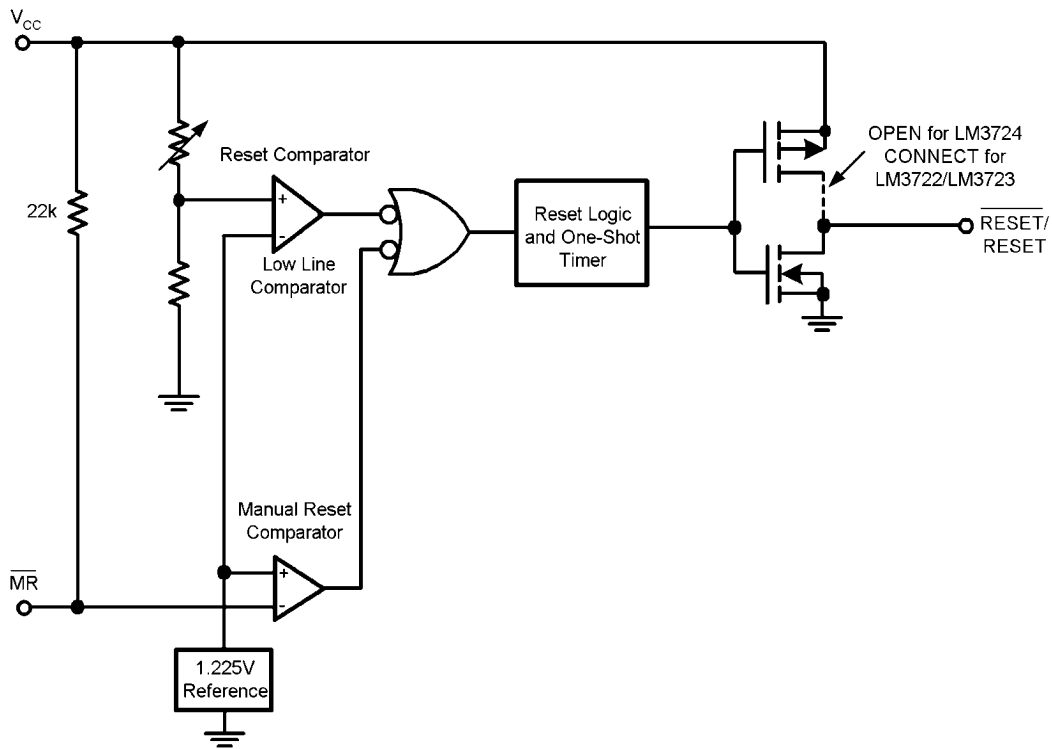

20014435

**Absolute Maximum Ratings** (Note 1)

If Military/Aerospace specified devices are required, please contact the National Semiconductor Sales Office/Distributors for availability and specifications.

$V_{CC}, \overline{MR}$	-0.3V to 6.0V
RESET, $\overline{RESET}$	-0.3V to ( $V_{CC} + 0.3V$ )
Input Current, $V_{CC}$ Pin	20mA
Output Current, RESET, $\overline{RESET}$ Pin	20mA
ESD Rating (Note 2)	2kV

Continuous Power Dissipation ( $T_A = +70^\circ\text{C}$ )

SOT-23 (Note 3)

320mW

Operating Temperature Range

Industrial:

-40°C to +85°C

Extended:

-40°C to +125°C

Maximum Junction Temperature

125°C

Storage Temperature Range

-65°C to +160°C

Lead Temperature (soldering, 10sec)

+300°C

**Electrical Characteristics**

Typical values are at  $T_A = +25^\circ\text{C}$ . Limits with standard typeface are for  $T_A = +25^\circ\text{C}$ , and limits in boldface type apply for the operating temperature range (-40°C to +85°C) for LM3722\_IM5X, and (-40°C to +125°C) for LM3722\_EM5X, unless otherwise noted. (Note 4)

Symbol	Parameter	Conditions	Min	Typ	Max	Units
$V_{CC}$	$V_{CC}$ Range		<b>1.0</b>		<b>5.5</b>	V
$I_{CC}$	Supply Current ( $I_{LOAD} = 0A$ )	LM3722 -4.63 $V_{CC} = 5.5V$		8	<b>15</b>	$\mu A$
		LM3722 -3.08 $V_{CC} = 3.6V$		7	<b>10</b>	
		LM3722 -2.32 $V_{CC} = 2.5V$		6	<b>10</b>	
$V_{TH}$	Reset Threshold	LM3722 -4.63	4.54 <b>4.50</b>	4.63	4.72 <b>4.75</b>	V
		LM3722 -3.08	3.03 <b>3.00</b>	3.08	3.14 <b>3.15</b>	
		LM3722 -2.32	2.27 <b>2.25</b>	2.32	2.37 <b>2.40</b>	
$V_{TH}$ Tempco	Reset Threshold Temperature Coefficient			30		ppm/°C
$t_{RD}$	$V_{CC}$ to Reset Delay (Note 5)	$V_{CC} = V_{TH}$ to ( $V_{TH} - 100mV$ )		20		$\mu s$
$t_{RP}$	Reset Active Timeout Period		<b>100</b>	190	<b>560</b>	ms
$t_{MR}$	$\overline{MR}$ Minimum Pulse Width		<b>10</b>			$\mu s$
$t_{MD}$	$\overline{MR}$ to Reset Propagation Delay			2		$\mu s$
	$\overline{MR}$ Glitch Immunity (Note 6)			100		ns
$V_{IH}$	$\overline{MR}$ Input Threshold	$V_{CC} > V_{TH(MAX)}$ , LM3722 -4.63	<b>2.3</b>			V
$V_{IL}$					<b>0.8</b>	
$V_{IH}$		$V_{CC} > V_{TH(MAX)}$ , LM3722 -3.08, LM3722 -2.32	<b>0.7 <math>V_{CC}</math></b>			
$V_{IL}$					<b>0.25 <math>V_{CC}</math></b>	
	$\overline{MR}$ Pull-Up Resistance			22		k $\Omega$
$V_{OL}$	$\overline{RESET}$ Output Voltage Low (LM3722)	$V_{CC} = V_{TH}$ min, $I_{SINK} = 1.2mA$ , (LM3722-2.32/3.08)			<b>0.3</b>	V
		$V_{CC} = V_{TH}$ min, $I_{SINK} = 3.2mA$ , (LM3722-4.63)			<b>0.4</b>	
		$V_{CC} > 1V$ , $I_{SINK} = 50\mu A$			<b>0.3</b>	
$V_{OH}$	$\overline{RESET}$ Output Voltage High (LM3722)	$V_{CC} > V_{TH}$ max, $I_{SOURCE} = 500\mu A$ , (LM3722-2.32/3.08)	<b>0.8 <math>V_{CC}</math></b>			V
		$V_{CC} > V_{TH}$ max, $I_{SOURCE} = 800\mu A$ , (LM3722-4.63)	<b><math>V_{CC} - 1.5</math></b>			
$V_{OL}$	RESET Output Voltage Low (LM3723)	$V_{CC} = V_{TH}$ max, $I_{SINK} = 1.2mA$ (LM3723 -2.32/3.08)			<b>0.3</b>	V
		$V_{CC} = V_{TH}$ max, $I_{SINK} = 3.2mA$ (LM3723 -4.63)			<b>0.4</b>	
$V_{OH}$	RESET Output Voltage High (LM3723)	$1.8V < V_{CC} < V_{TH}$ min, $I_{SOURCE} = 150\mu A$	<b>0.8 <math>V_{CC}</math></b>			V

Symbol	Parameter	Conditions	Min	Typ	Max	Units
$V_{OL}$	RESET Output Voltage Low (LM3724)	$V_{CC} = V_{TH} \text{ min, } I_{SINK} = 1.2 \text{ mA}$ (LM3724 -2.32/3.08)			0.3	V
		$V_{CC} = V_{TH} \text{ min, } I_{SINK} = 3.2 \text{ mA}$ (LM3724 -4.63)			0.4	
		$V_{CC} > 1V, I_{SINK} = 50\mu A$			0.3	
$I_{IN}$	RESET Output Leakage Current (LM3724)	$V_{CC} > V_{TH}, \overline{\text{RESET}} = 5.5V$			0.5	$\mu A$

**Note 1:** Absolute Maximum Ratings are limits beyond which damage to the device may occur. Operating Ratings are conditions under which the device operates correctly. Operating ratings do not imply guaranteed performance limits. For guaranteed performance limits and associated test conditions, see the Electrical Characteristics.

**Note 2:** The human body model is a 100pF capacitor discharged through a 1.5k $\Omega$  resistor into each pin.

**Note 3:** At elevated temperatures, devices must be derated based on package thermal resistance. The device in the SOT23-5 package must be derated at 4.5mW/ $^{\circ}C$  at ambient temperatures above 70 $^{\circ}C$ . The device has internal thermal protection.

**Note 4:** Production testing done at  $T_A = +25^{\circ}C$ . Limits over the operating temperature range are guaranteed through correlation using Statistical Quality Control (SQC) methods.

**Note 5:** RESET Output for LM3722 and LM3724, RESET output for LM3723.

**Note 6:** Glitches of 100 ns or less typically will not generate a reset pulse.

## Typical Performance Characteristics

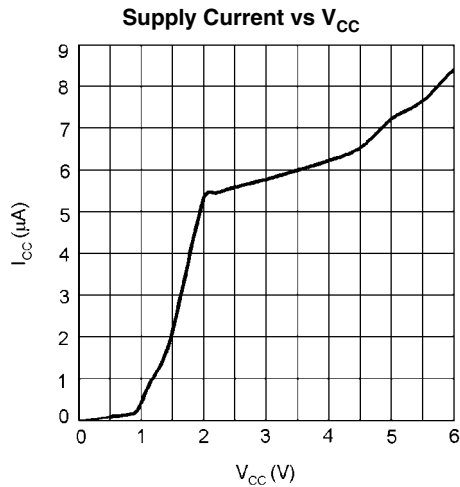

20014403

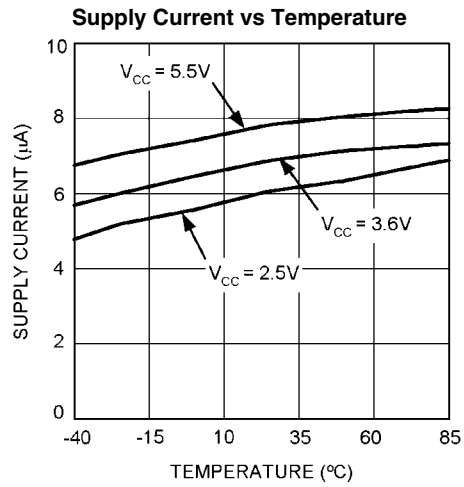

20014407

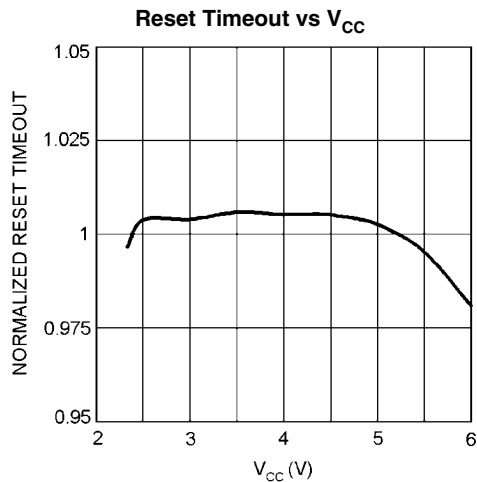

20014404

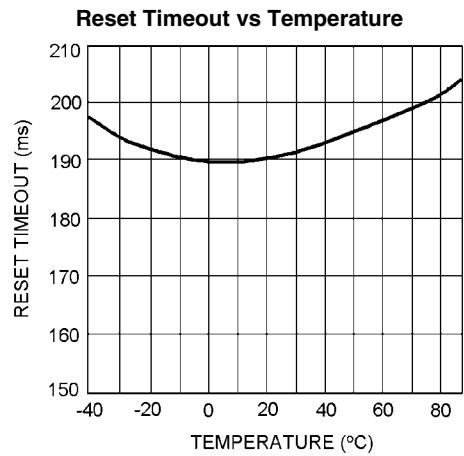

20014408

Normalized  $V_{TH}$  vs Temperature

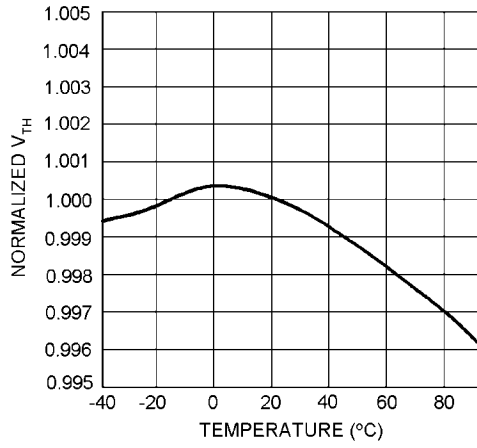

20014416

LM3724  $V_{OL}$  vs Current

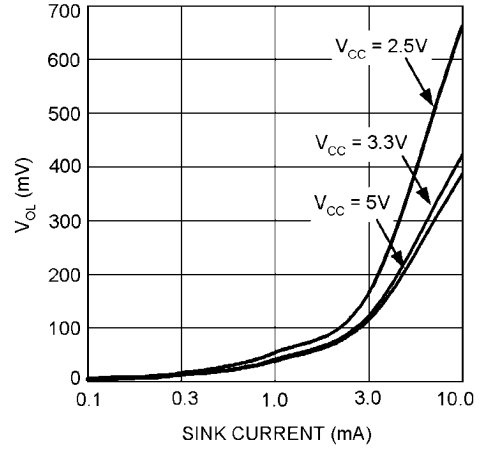

20014405

LM3724 Low  $V_{CC}$  Characteristics

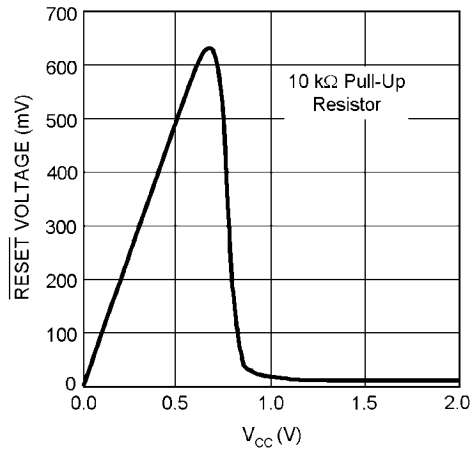

20014406

## Timing Diagram

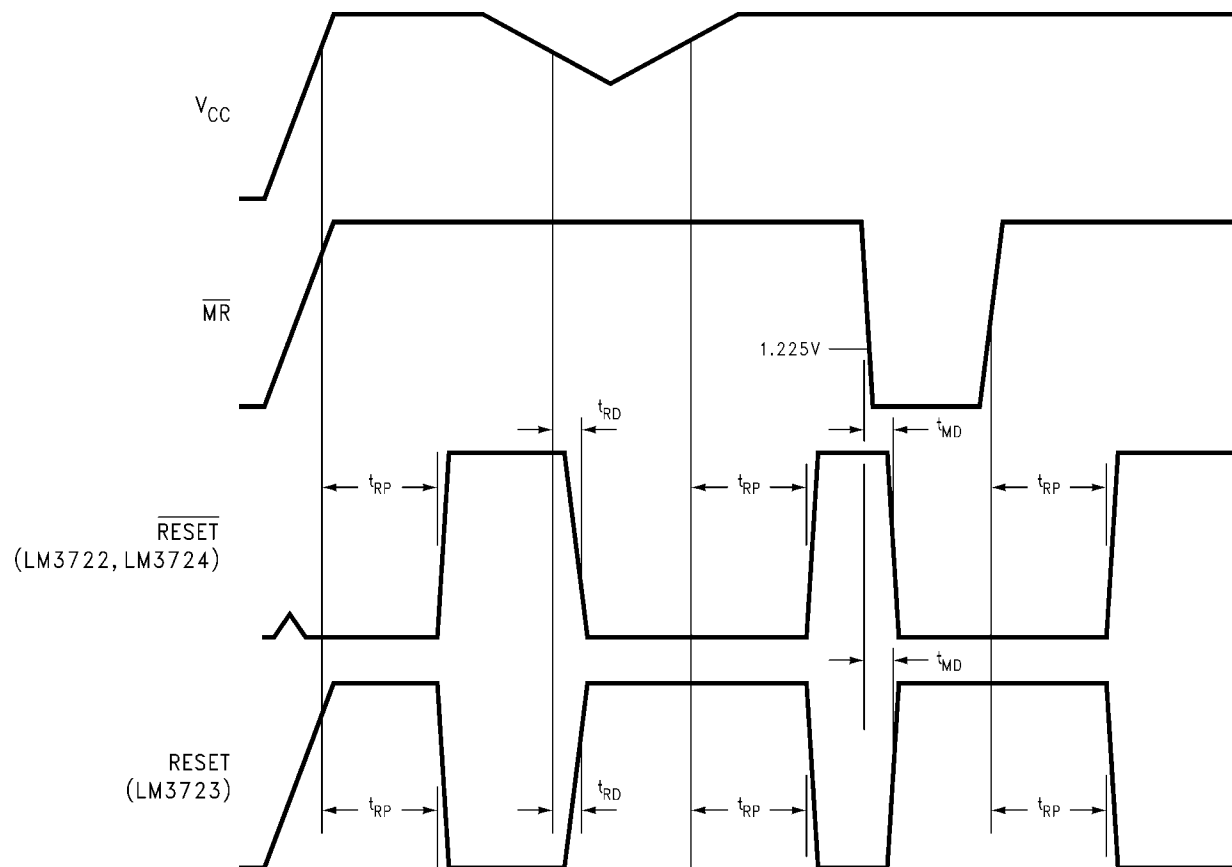

20014412

## Circuit Information

### RESET OUTPUT

The reset input of a  $\mu P$  initializes the device into a known state. The LM3722/LM3723/LM3724 microprocessor voltage monitoring circuits assert a forced reset output to prevent code execution errors during power-up, power-down, and brownout conditions.

$\overline{RESET}$  is guaranteed valid for  $V_{CC} \geq 1V$ . Once  $V_{CC}$  exceeds the reset threshold, an internal timer maintains the output for the reset timeout period. After this interval, reset goes high and the microprocessor initializes itself into a known state. The LM3722 and LM3724 offer an active-low  $\overline{RESET}$ ; the LM3723 offers an active-high  $RESET$ .

As  $V_{CC}$  drops below the reset threshold (such as during a brownout), the reset activates (see the *Negative-Going  $V_{CC}$  Transients* section). When  $V_{CC}$  again rises above the reset threshold, the internal timer starts. Reset holds until  $V_{CC}$  exceeds the reset threshold for longer than the reset timeout period. After this time, reset releases.

Additionally, the Manual Reset input ( $\overline{MR}$ ) will initiate a forced reset. See the *Manual Reset Input* section.

The LM3722/LM3723/LM3724 reset outputs ignore short duration glitches on  $V_{CC}$  and  $\overline{MR}$ . See the *Applications Information* section for details.

### RESET THRESHOLD

The LM3722/LM3723/LM3724 are available with reset voltages of 4.63V, 3.08V, and 2.32V which are suitable for mon-

itoring 5.0V, 3.3V, and 2.5V supplies respectively. Other reset thresholds in the 2.20V to 5.0V range, in 10 mV steps, are available; contact National Semiconductor for details.

### MANUAL RESET INPUT ( $\overline{MR}$ )

Many  $\mu P$ -based products require a manual reset capability, allowing the operator to initiate a reset. The  $\overline{MR}$  input is fully debounced and provides an internal 22 k $\Omega$  pull-up. When the  $\overline{MR}$  input is pulled below  $V_{IL}$  ( $0.25V_{CC}$ ) for more than 100 ns, reset is asserted after a typical delay of 2  $\mu s$ . Reset remains active as long as  $\overline{MR}$  is held low, and releases after  $\overline{MR}$  rises above  $V_{IH}$  and the reset timeout period expires. Use  $\overline{MR}$  with digital logic to assert reset or to daisy chain supervisory circuits.

## Applications Information

### BENEFITS OF PRECISION RESET THRESHOLDS

A microprocessor supply supervisor must provide a reset output within a predictable range of the supply voltage. A common threshold range is between 5% and 10% below the nominal supply voltage. The 4.63V, 3.08V and 2.32V options of the LM3722/LM3723/LM3724 use highly accurate circuitry to ensure that the reset threshold occurs only within this range (for 5.0V, 3.3V and 2.5V supplies). *Table 1* shows how the standard reset thresholds apply to 5.0V, 3.3V, and 2.5V nominal supply voltages.



TABLE 1. Monitored Tolerance Table

Reset Threshold	Supply Voltage		
	2.5V	3.3V	5.0V
4.63 ± %			90.8-94.4 %
3.08 ± %		91.8-95.2 %	
2.32 ± %	90.8-94.8 %		

**ENSURING A VALID RESET OUTPUT DOWN TO  $V_{CC} = 0V$** 

When  $V_{CC}$  falls below 1V, the LM3722  $\overline{RESET}$  output is unable to sink the rated current. A high-impedance CMOS logic input connected to  $\overline{RESET}$  can therefore drift to undetermined voltages. To prevent this situation, a 100k $\Omega$  resistor should be connected from the  $\overline{RESET}$  output to ground, as shown in Figure 1.

A 100k $\Omega$  pull-up resistor to  $V_{CC}$  is also recommended for the LM3723, if  $\overline{RESET}$  is required to remain valid for  $V_{CC} < 1V$ .

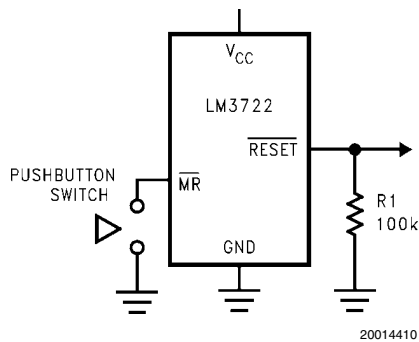
FIGURE 1. Circuit for  $\overline{RESET}$  Valid from  $V_{CC} = 0V$ **OPEN DRAIN OUTPUT (LM3724)**

An open drain output allows easy paralleling of multiple microprocessor reset circuits without requiring additional logic gates. Open drain outputs also allow interfacing devices of differing logic levels or families, since the output pull-up resistor may be connected to any supply voltage up to 5.5V, regardless of LM3724  $V_{CC}$ .

The pull up resistor is calculated so that maximum current flow into  $\overline{RESET}$  is less than 10 mA when activated. The resistor must be small enough so that the leakage current of all con-

nected devices does not create an excessive voltage drop when the output is not activated. A resistor value of 100 k $\Omega$  will generally suffice.

**NEGATIVE-GOING  $V_{CC}$  TRANSIENTS**

The LM3722/LM3723/LM3724 are relatively immune to short negative-going transients or glitches on  $V_{CC}$ . Figure 2 shows the maximum pulse width a negative-going  $V_{CC}$  transient can have without causing a reset pulse. In general, as the magnitude of the transient increases, going further below the threshold, the maximum allowable pulse width decreases. Typically, a  $V_{CC}$  transient that goes 125 mV below the reset threshold and lasts 40  $\mu s$  or less will not cause a reset pulse. A 0.1  $\mu F$  bypass capacitor mounted as close as possible to the  $V_{CC}$  pin will provide additional transient rejection.

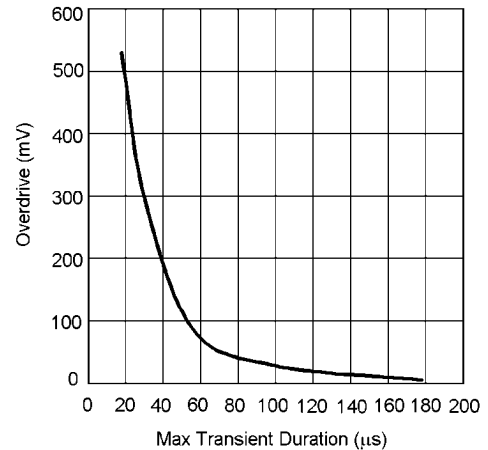

20014414

FIGURE 2. Maximum Transient Duration without Causing a Reset Pulse vs. Reset Comparator Overdrive

**INTERFACING TO  $\mu PS$  WITH BIDIRECTIONAL RESET PINS**

Microprocessors with bidirectional reset pins, such as the Motorola 68HC11 series, can be connected to the LM3722  $\overline{RESET}$  output. To ensure a correct output on the LM3722 even when the microprocessor reset pin is in the opposite state, connect a 4.7k $\Omega$  resistor between the LM3722  $\overline{RESET}$  output and the  $\mu P$  reset pin, as shown in Figure 3. Buffer the LM3722  $\overline{RESET}$  output to other system components.

# Typical Application Circuits

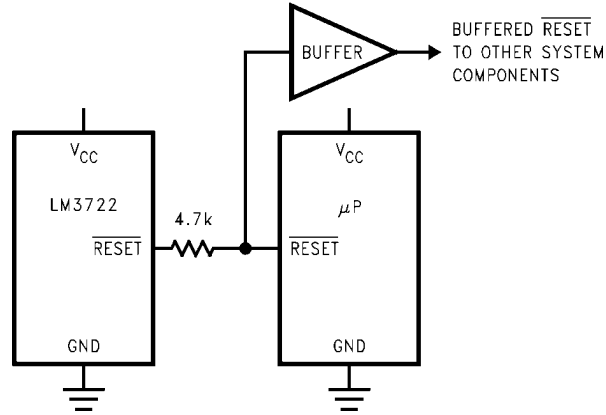

20014411

FIGURE 3. Interfacing to Microprocessors with Bidirectional Reset I/O

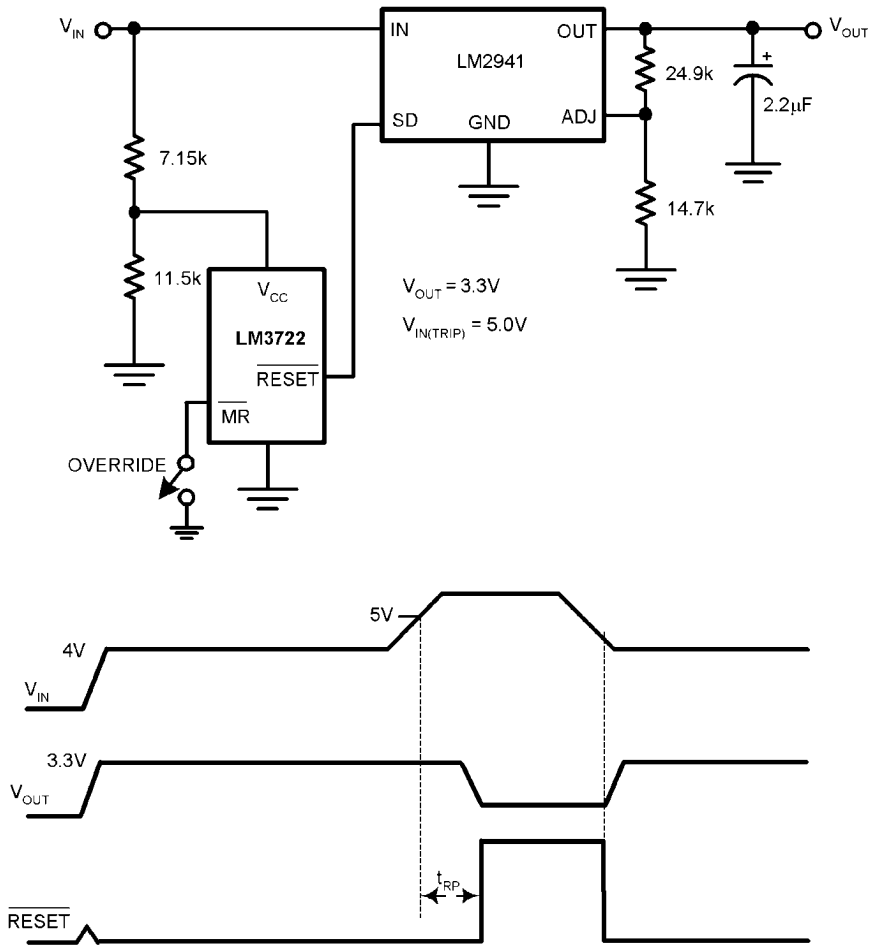

20014422

FIGURE 4. Regulator/Switch with Long-Term Overvoltage Lockout Prevents Overdissipation in Linear Regulator

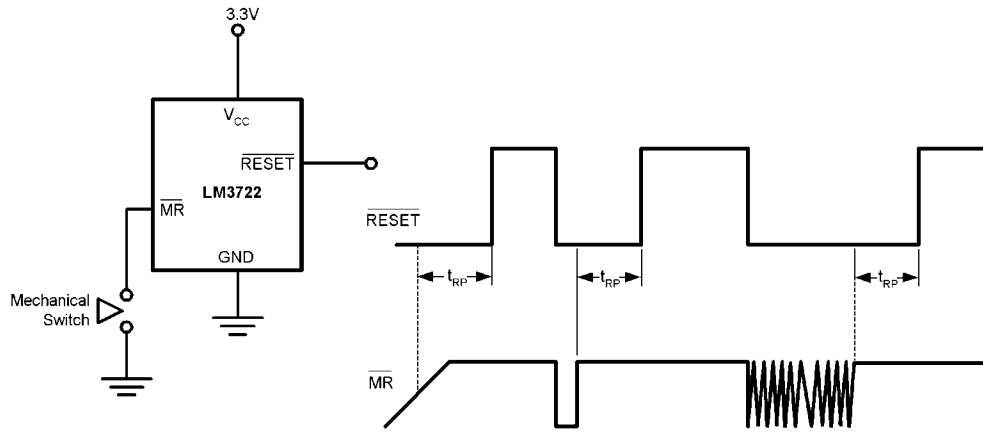

20014431

FIGURE 5. LM3722 Switch Debouncer

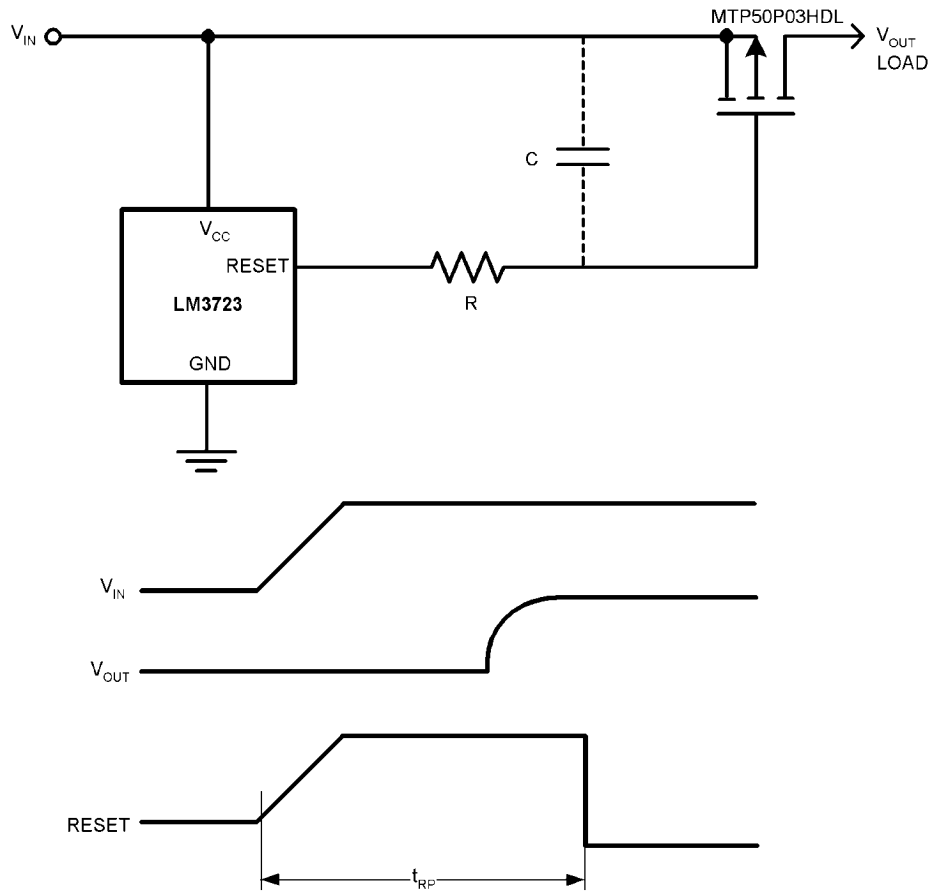

20014424

FIGURE 6. LM3723 Power-On Delay

**Physical Dimensions** inches (millimeters) unless otherwise noted

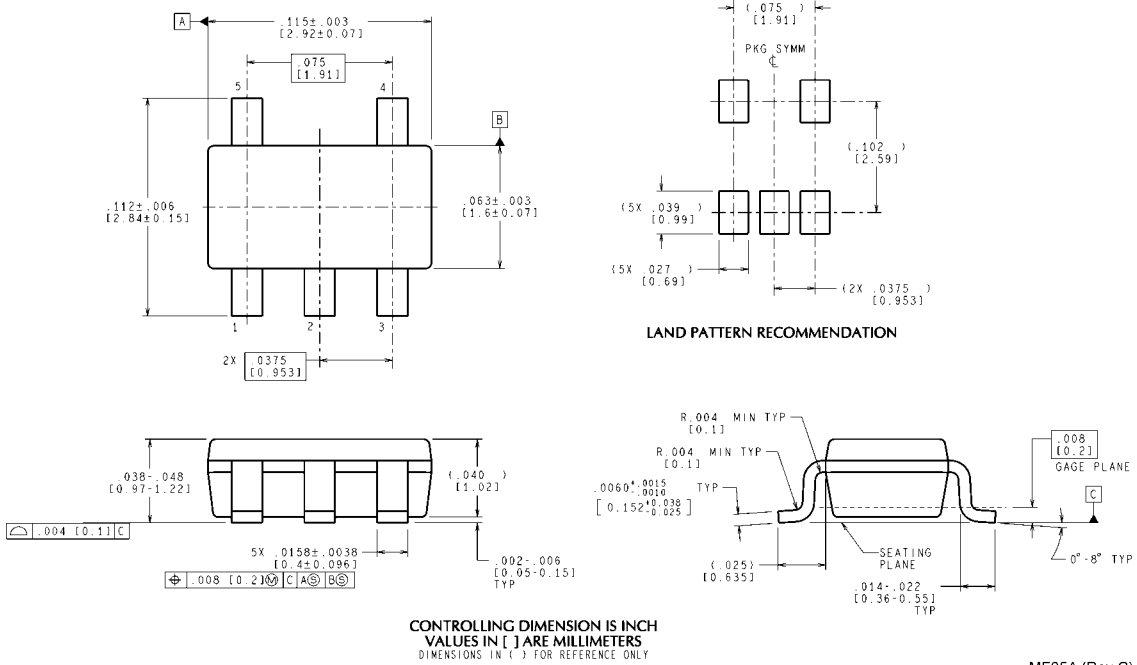

**5-Lead SOT23-5**  
**For Ordering, refer to Ordering Information table**  
**NS Package Number MF05A**

MF05A (Rev C)

## Notes

THE CONTENTS OF THIS DOCUMENT ARE PROVIDED IN CONNECTION WITH NATIONAL SEMICONDUCTOR CORPORATION ("NATIONAL") PRODUCTS. NATIONAL MAKES NO REPRESENTATIONS OR WARRANTIES WITH RESPECT TO THE ACCURACY OR COMPLETENESS OF THE CONTENTS OF THIS PUBLICATION AND RESERVES THE RIGHT TO MAKE CHANGES TO SPECIFICATIONS AND PRODUCT DESCRIPTIONS AT ANY TIME WITHOUT NOTICE. NO LICENSE, WHETHER EXPRESS, IMPLIED, ARISING BY ESTOPPEL OR OTHERWISE, TO ANY INTELLECTUAL PROPERTY RIGHTS IS GRANTED BY THIS DOCUMENT.

TESTING AND OTHER QUALITY CONTROLS ARE USED TO THE EXTENT NATIONAL DEEMS NECESSARY TO SUPPORT NATIONAL'S PRODUCT WARRANTY. EXCEPT WHERE MANDATED BY GOVERNMENT REQUIREMENTS, TESTING OF ALL PARAMETERS OF EACH PRODUCT IS NOT NECESSARILY PERFORMED. NATIONAL ASSUMES NO LIABILITY FOR APPLICATIONS ASSISTANCE OR BUYER PRODUCT DESIGN. BUYERS ARE RESPONSIBLE FOR THEIR PRODUCTS AND APPLICATIONS USING NATIONAL COMPONENTS. PRIOR TO USING OR DISTRIBUTING ANY PRODUCTS THAT INCLUDE NATIONAL COMPONENTS, BUYERS SHOULD PROVIDE ADEQUATE DESIGN, TESTING AND OPERATING SAFEGUARDS.

EXCEPT AS PROVIDED IN NATIONAL'S TERMS AND CONDITIONS OF SALE FOR SUCH PRODUCTS, NATIONAL ASSUMES NO LIABILITY WHATSOEVER, AND NATIONAL DISCLAIMS ANY EXPRESS OR IMPLIED WARRANTY RELATING TO THE SALE AND/OR USE OF NATIONAL PRODUCTS INCLUDING LIABILITY OR WARRANTIES RELATING TO FITNESS FOR A PARTICULAR PURPOSE, MERCHANTABILITY, OR INFRINGEMENT OF ANY PATENT, COPYRIGHT OR OTHER INTELLECTUAL PROPERTY RIGHT.

### LIFE SUPPORT POLICY

**NATIONAL'S PRODUCTS ARE NOT AUTHORIZED FOR USE AS CRITICAL COMPONENTS IN LIFE SUPPORT DEVICES OR SYSTEMS WITHOUT THE EXPRESS PRIOR WRITTEN APPROVAL OF THE CHIEF EXECUTIVE OFFICER AND GENERAL COUNSEL OF NATIONAL SEMICONDUCTOR CORPORATION.** As used herein:

Life support devices or systems are devices which (a) are intended for surgical implant into the body, or (b) support or sustain life and whose failure to perform when properly used in accordance with instructions for use provided in the labeling can be reasonably expected to result in a significant injury to the user. A critical component is any component in a life support device or system whose failure to perform can be reasonably expected to cause the failure of the life support device or system or to affect its safety or effectiveness.

National Semiconductor and the National Semiconductor logo are registered trademarks of National Semiconductor Corporation. All other brand or product names may be trademarks or registered trademarks of their respective holders.

Copyright© 2007 National Semiconductor Corporation

For the most current product information visit us at [www.national.com](http://www.national.com)



**National Semiconductor  
Americas Customer  
Support Center**  
Email:  
[new.feedback@nsc.com](mailto:new.feedback@nsc.com)  
Tel: 1-800-272-9959

**National Semiconductor Europe  
Customer Support Center**  
Fax: +49 (0) 180-530-85-86  
Email: [europe.support@nsc.com](mailto:europe.support@nsc.com)  
Deutsch Tel: +49 (0) 69 9508 6208  
English Tel: +49 (0) 870 24 0 2171  
Français Tel: +33 (0) 1 41 91 8790

**National Semiconductor Asia  
Pacific Customer Support Center**  
Email: [ap.support@nsc.com](mailto:ap.support@nsc.com)

**National Semiconductor Japan  
Customer Support Center**  
Fax: 81-3-5639-7507  
Email: [jpn.feedback@nsc.com](mailto:jpn.feedback@nsc.com)  
Tel: 81-3-5639-7560