

To our customers,

Old Company Name in Catalogs and Other Documents

On April 1st, 2010, NEC Electronics Corporation merged with Renesas Technology Corporation, and Renesas Electronics Corporation took over all the business of both companies. Therefore, although the old company name remains in this document, it is a valid Renesas Electronics document. We appreciate your understanding.

Renesas Electronics website: <http://www.renesas.com>

April 1st, 2010
Renesas Electronics Corporation

Issued by: Renesas Electronics Corporation (<http://www.renesas.com>)

Send any inquiries to <http://www.renesas.com/inquiry>.

Notice

1. All information included in this document is current as of the date this document is issued. Such information, however, is subject to change without any prior notice. Before purchasing or using any Renesas Electronics products listed herein, please confirm the latest product information with a Renesas Electronics sales office. Also, please pay regular and careful attention to additional and different information to be disclosed by Renesas Electronics such as that disclosed through our website.
2. Renesas Electronics does not assume any liability for infringement of patents, copyrights, or other intellectual property rights of third parties by or arising from the use of Renesas Electronics products or technical information described in this document. No license, express, implied or otherwise, is granted hereby under any patents, copyrights or other intellectual property rights of Renesas Electronics or others.
3. You should not alter, modify, copy, or otherwise misappropriate any Renesas Electronics product, whether in whole or in part.
4. Descriptions of circuits, software and other related information in this document are provided only to illustrate the operation of semiconductor products and application examples. You are fully responsible for the incorporation of these circuits, software, and information in the design of your equipment. Renesas Electronics assumes no responsibility for any losses incurred by you or third parties arising from the use of these circuits, software, or information.
5. When exporting the products or technology described in this document, you should comply with the applicable export control laws and regulations and follow the procedures required by such laws and regulations. You should not use Renesas Electronics products or the technology described in this document for any purpose relating to military applications or use by the military, including but not limited to the development of weapons of mass destruction. Renesas Electronics products and technology may not be used for or incorporated into any products or systems whose manufacture, use, or sale is prohibited under any applicable domestic or foreign laws or regulations.
6. Renesas Electronics has used reasonable care in preparing the information included in this document, but Renesas Electronics does not warrant that such information is error free. Renesas Electronics assumes no liability whatsoever for any damages incurred by you resulting from errors in or omissions from the information included herein.
7. Renesas Electronics products are classified according to the following three quality grades: “Standard”, “High Quality”, and “Specific”. The recommended applications for each Renesas Electronics product depends on the product’s quality grade, as indicated below. You must check the quality grade of each Renesas Electronics product before using it in a particular application. You may not use any Renesas Electronics product for any application categorized as “Specific” without the prior written consent of Renesas Electronics. Further, you may not use any Renesas Electronics product for any application for which it is not intended without the prior written consent of Renesas Electronics. Renesas Electronics shall not be in any way liable for any damages or losses incurred by you or third parties arising from the use of any Renesas Electronics product for an application categorized as “Specific” or for which the product is not intended where you have failed to obtain the prior written consent of Renesas Electronics. The quality grade of each Renesas Electronics product is “Standard” unless otherwise expressly specified in a Renesas Electronics data sheets or data books, etc.
 - “Standard”: Computers; office equipment; communications equipment; test and measurement equipment; audio and visual equipment; home electronic appliances; machine tools; personal electronic equipment; and industrial robots.
 - “High Quality”: Transportation equipment (automobiles, trains, ships, etc.); traffic control systems; anti-disaster systems; anti-crime systems; safety equipment; and medical equipment not specifically designed for life support.
 - “Specific”: Aircraft; aerospace equipment; submersible repeaters; nuclear reactor control systems; medical equipment or systems for life support (e.g. artificial life support devices or systems), surgical implantations, or healthcare intervention (e.g. excision, etc.), and any other applications or purposes that pose a direct threat to human life.
8. You should use the Renesas Electronics products described in this document within the range specified by Renesas Electronics, especially with respect to the maximum rating, operating supply voltage range, movement power voltage range, heat radiation characteristics, installation and other product characteristics. Renesas Electronics shall have no liability for malfunctions or damages arising out of the use of Renesas Electronics products beyond such specified ranges.
9. Although Renesas Electronics endeavors to improve the quality and reliability of its products, semiconductor products have specific characteristics such as the occurrence of failure at a certain rate and malfunctions under certain use conditions. Further, Renesas Electronics products are not subject to radiation resistance design. Please be sure to implement safety measures to guard them against the possibility of physical injury, and injury or damage caused by fire in the event of the failure of a Renesas Electronics product, such as safety design for hardware and software including but not limited to redundancy, fire control and malfunction prevention, appropriate treatment for aging degradation or any other appropriate measures. Because the evaluation of microcomputer software alone is very difficult, please evaluate the safety of the final products or system manufactured by you.
10. Please contact a Renesas Electronics sales office for details as to environmental matters such as the environmental compatibility of each Renesas Electronics product. Please use Renesas Electronics products in compliance with all applicable laws and regulations that regulate the inclusion or use of controlled substances, including without limitation, the EU RoHS Directive. Renesas Electronics assumes no liability for damages or losses occurring as a result of your noncompliance with applicable laws and regulations.
11. This document may not be reproduced or duplicated, in any form, in whole or in part, without prior written consent of Renesas Electronics.
12. Please contact a Renesas Electronics sales office if you have any questions regarding the information contained in this document or Renesas Electronics products, or if you have any other inquiries.

(Note 1) “Renesas Electronics” as used in this document means Renesas Electronics Corporation and also includes its majority-owned subsidiaries.

(Note 2) “Renesas Electronics product(s)” means any product developed or manufactured by or for Renesas Electronics.

To all our customers

Regarding the change of names mentioned in the document, such as Mitsubishi Electric and Mitsubishi XX, to Renesas Technology Corp.

The semiconductor operations of Hitachi and Mitsubishi Electric were transferred to Renesas Technology Corporation on April 1st 2003. These operations include microcomputer, logic, analog and discrete devices, and memory chips other than DRAMs (flash memory, SRAMs etc.) Accordingly, although Mitsubishi Electric, Mitsubishi Electric Corporation, Mitsubishi Semiconductors, and other Mitsubishi brand names are mentioned in the document, these names have in fact all been changed to Renesas Technology Corp. Thank you for your understanding. Except for our corporate trademark, logo and corporate statement, no changes whatsoever have been made to the contents of the document, and these changes do not constitute any alteration to the contents of the document itself.

Note : Mitsubishi Electric will continue the business operations of high frequency & optical devices and power devices.

Renesas Technology Corp.
Customer Support Dept.
April 1, 2003

M37272M6H/M8H/MAH/MFH-XXXSP/FP M37272E8SP/FP, M37272EFSP/FP

SINGLE-CHIP 8-BIT CMOS MICROCOMPUTER with CLOSED CAPTION DECODER
and ON-SCREEN DISPLAY CONTROLLER

1. DESCRIPTION

The M37272M6H/M8H/MAH/MFH-XXXSP/FP are single-chip micro-computers designed with CMOS silicon gate technology. They have a OSD, data slicer, and I²C-BUS interface, so it is useful for a channel selection system for TV with a closed caption decoder.

The features of the M37272E8SP/FP and M37272EFSP/FP are similar to those of the M37272M6H-XXXSP/FP except that the chip has a built-in PROM which can be written electrically. The difference between M37272M6H/M8H/MAH/MFH-XXXSP/FP are the ROM size and RAM size. Accordingly, the following descriptions will be for the M37272M6H-XXXSP/FP.

2. FEATURES

- Number of basic instructions 71
- Memory size
 - ROM 24K bytes
(M37272M6H-XXXSP/FP)
 - 32K bytes
(M37272M8H-XXXSP/FP, M37272E8SP/FP)
 - 40K bytes
(M37272MAH-XXXSP/FP)
 - 60K bytes
(M37272MFH-XXXSP/FP, M37272EFSP/FP)
 - RAM 1024 bytes
(M37272M6H-XXXSP/FP)
 - 1152 bytes
(M37272M8H-XXXSP/FP, M37272E8SP/FP)
 - 1472 bytes
(M37272MAH-XXXSP/FP, M37272MFH-XXXSP/FP, M37272EFSP/FP)

(*ROM correction memory included)
- Minimum instruction execution time 0.5 μs (at 8 MHz oscillation frequency)
- Power source voltage 5 V ± 10 %
- Subroutine nesting 128 levels (Max.)
- Interrupts 17 types, 16 vectors
- 8-bit timers 6
- Programmable I/O ports (Ports P0, P1, P2, P30, P31) 26
- Input ports (Ports P50, P51) 2
- Output ports (Ports P52–P55) 4
- 12 V withstand ports 6
- LED drive ports 4
- Serial I/O 8-bit X 1 channel
- Multi-master I²C-BUS interface 1 (2 systems)
- A-D comparator (6-bit resolution) 6 channels
- PWM output circuit 8-bit X 6
- Power dissipation
 - In high-speed mode 165 mW
(at Vcc = 5.5V, 8 MHz oscillation frequency, OSD on, and Data slicer on)
 - In low-speed mode 0.33 mW
(at Vcc = 5.5V, 32 kHz oscillation frequency)
- ROM correction function 2 vectors

- Closed caption data slicer
- OSD function
 - Display characters 32 characters X 2 lines
(It is possible to display 3 lines or more by software)
 - Kinds of characters 254 kinds
 - Character display area CC mode: 16 X 26 dots
OSD mode: 16 X 20 dots
 - Kinds of character sizes CC mode: 1 kind
OSD mode: 8 kinds
 - Kinds of character colors 8 colors (R, G, B)
 - Coloring unit character, character background, raster
 - Display position
 - Horizontal: 128 levels Vertical: 512 levels
 - Attribute
 - CC mode: smooth italic, underline, flash, automatic solid space
 - OSD mode: border
 - Smooth roll-up
 - Window function

3. APPLICATION

TV with a closed caption decoder

M37272M6H/M8H/MAH/MFH-XXXSP/FP M37272E8SP/FP, M37272EFSP/FP

SINGLE-CHIP 8-BIT CMOS MICROCOMPUTER with CLOSED CAPTION DECODER
and ON-SCREEN DISPLAY CONTROLLER

TABLE OF CONTENTS

1. DESCRIPTION	1	9. PROGRAMMING NOTES	96
2. FEATURES	1	10. ABSOLUTE MAXIMUM RATINGS	97
3. APPLICATION	1	11. RECOMMENDED OPERATING CONDITIONS	97
4. PIN CONFIGURATION	3	12. ELECTRIC CHARACTERISTICS	98
5. FUNCTIONAL BLOCK DIAGRAM	4	13. A-D CONVERTER CHARACTERISTICS	100
6. PERFORMANCE OVERVIEW	5	14. MULTI-MASTER I2C-BUS BUS LINE CHARACTERISTICS	100
7. PIN DESCRIPTION	7	15. PROM PROGRAMMING METHOD	101
8. FUNCTIONAL DESCRIPTION	11	16. DATA REQUIRED FOR MASK ORDERS	102
8.1 CENTRAL PROCESSING UNIT (CPU)	11	17. ONE TIME PROM VERSION M37272E8SP/FP, M37272EFSP/FP MARKING	103
8.2 MEMORY	12	18. APPENDIX	104
8.3 INTERRUPTS	18	19. PACKAGE OUTLINE	129
8.4 TIMERS	23		
8.5 SERIAL I/O	26		
8.6 MULTI-MASTER I2C-BUS INTERFACE	29		
8.7 PWM OUTPUT FUNCTION	42		
8.8 A-D COMPARATOR	46		
8.9 ROM CORRECTION FUNCTION	48		
8.10 DATA SLICER	49		
8.11 OSD FUNCTIONS	60		
8.11.1 Display Position	65		
8.11.2 Dot Size	69		
8.11.3 Clock for OSD	70		
8.11.4 Field Determination Display	71		
8.11.5 Memory for OSD	73		
8.11.6 Character color	77		
8.11.7 Character background color	77		
8.11.8 OUT1, OUT2 signals	78		
8.11.9 Attribute	79		
8.11.10 Multiline Display	84		
8.11.11 Automatic Solid Space Function	85		
8.11.12 Window Function	86		
8.11.13 OSD Output Pin Control	88		
8.11.14 Raster Coloring Function	89		
8.12 SOFTWARE RUNAWAY DETECT FUNCTION	91		
8.13. RESET CIRCUIT	92		
8.14 CLOCK GENERATING CIRCUIT	93		
8.15 DISPLAY OSCILLATION CIRCUIT	96		
8.16 AUTO-CLEAR CIRCUIT	96		
8.17 ADDRESSING MODE	96		
8.18 MACHINE INSTRUCTIONS	96		

M37272M6H/M8H/MAH/MFH-XXXSP/FP M37272E8SP/FP, M37272EFSP/FP

SINGLE-CHIP 8-BIT CMOS MICROCOMPUTER with CLOSED CAPTION DECODER
and ON-SCREEN DISPLAY CONTROLLER

4. PIN CONFIGURATION

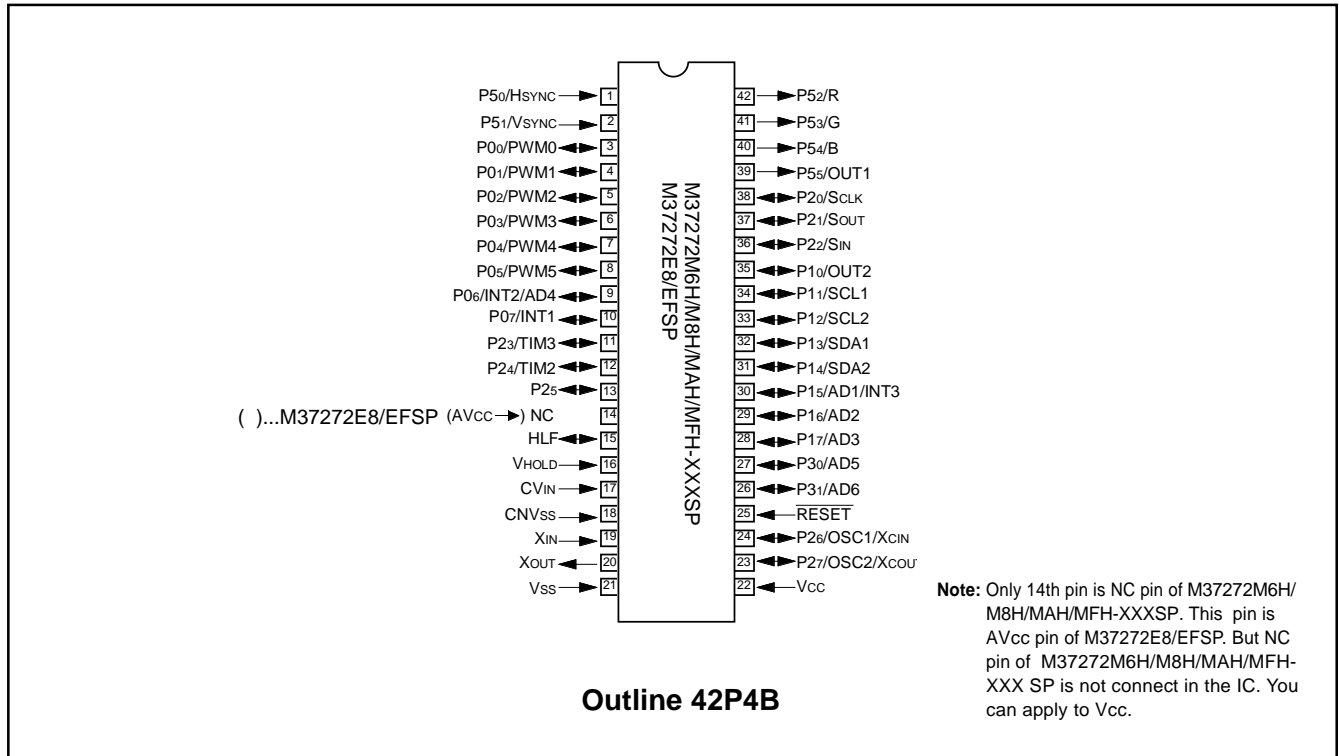

Fig. 4.1 Pin Configuration (1) (Top View)

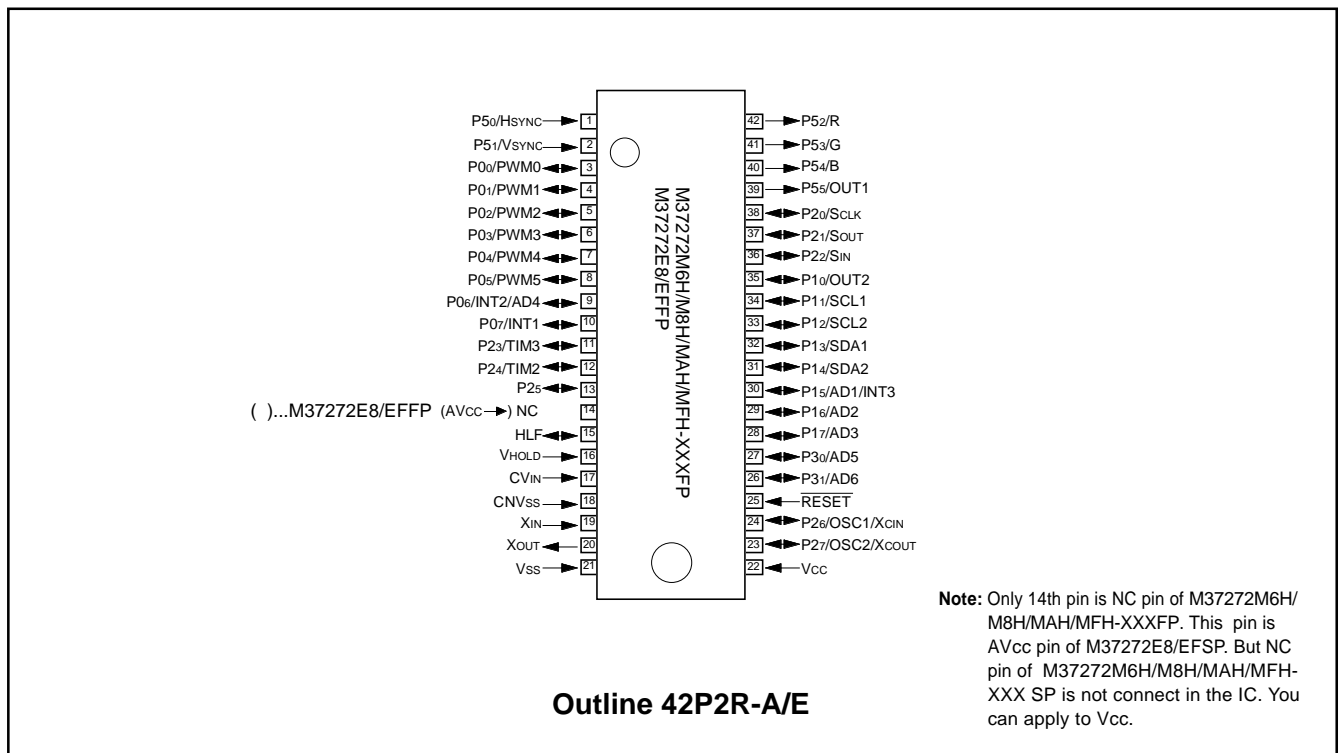

Fig. 4.2 Pin Configuration (2) (Top View)

M37272M6H/M8H/MAH/MFH-XXXSP/FP M37272E8SP/FP, M37272EFSP/FP

SINGLE-CHIP 8-BIT CMOS MICROCOMPUTER with CLOSED CAPTION DECODER
and ON-SCREEN DISPLAY CONTROLLER

5. FUNCTIONAL BLOCK DIAGRAM

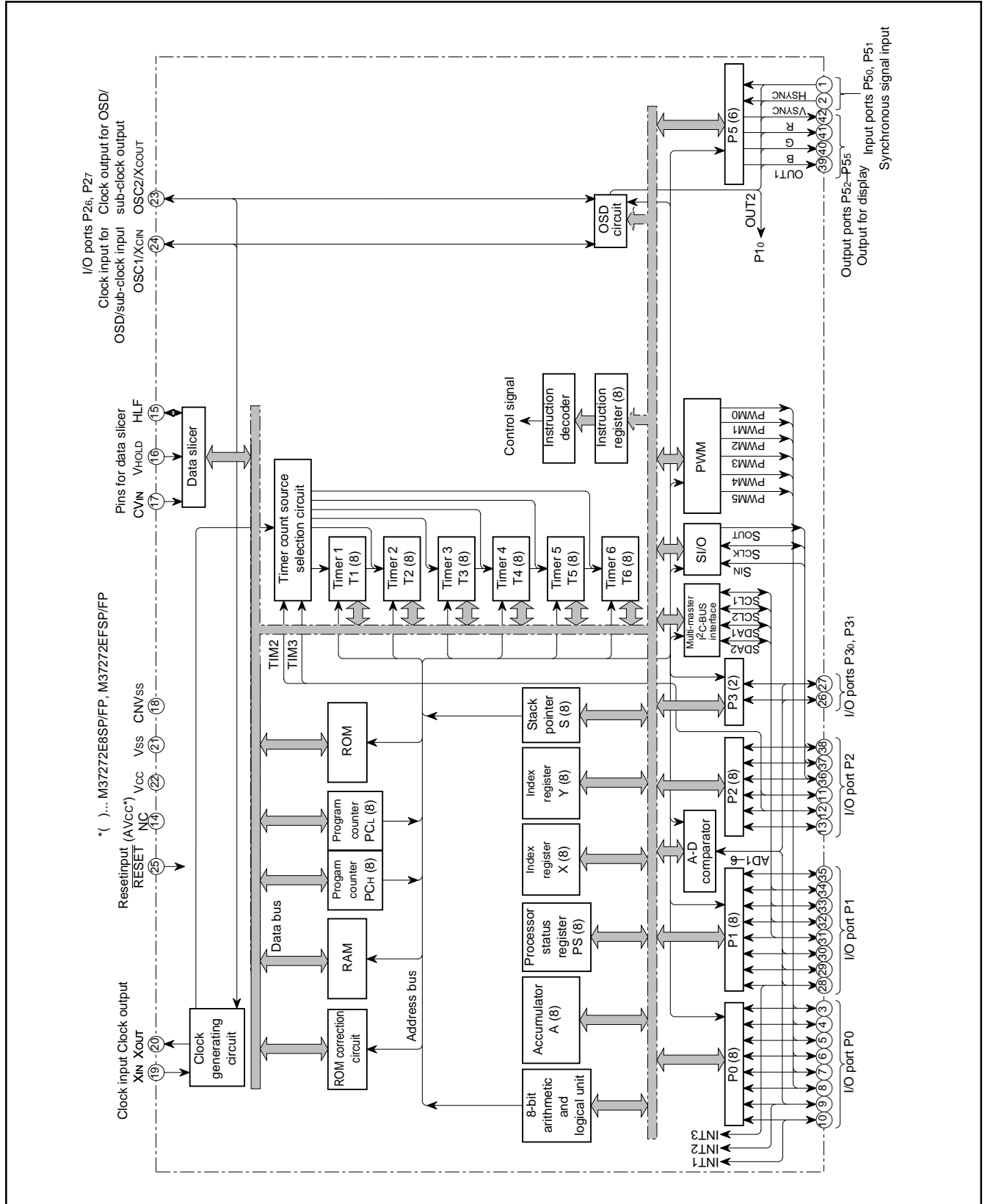

Fig. 5.1 Functional Block Diagram of M37272

M37272M6H/M8H/MAH/MFH-XXXSP/FP M37272E8SP/FP, M37272EFSP/FP

SINGLE-CHIP 8-BIT CMOS MICROCOMPUTER with CLOSED CAPTION DECODER
and ON-SCREEN DISPLAY CONTROLLER

6. PERFORMANCE OVERVIEW

Table 6.1 Performance Overview

Parameter		Functions	
Number of basic instructions		71	
Instruction execution time		0.5 μ s (the minimum instruction execution time, at 8 MHz oscillation frequency)	
Clock frequency		8 MHz (maximum)	
Memory size	ROM	M37272M6H-XXXSP/FP	24K bytes
		M37272M8H-XXXSP/FP, M37272E8SP/FP	32K bytes
		M37272MAH-XXXSP/FP	40K bytes
		M37272MFH-XXXSP/FP, M37272EFSP/FP	60K bytes
	RAM	M37272M6H-XXXSP/FP	1024 bytes (ROM correction memory included)
		M37272M8H-XXXSP/FP, M37272E8SP/FP	1152 bytes (ROM correction memory included)
		M37272MAH-XXXSP/FP, M37272MFH-XXXSP/FP, M37272EFSP/FP	1472 bytes (ROM correction memory included)
OSD ROM		10K bytes	
OSD RAM		128 bytes	
Input/Output ports	P0	I/O	8-bit \times 1 (N-channel open-drain output structure, can be used as PWM output pins, INT input pins, A-D input pin)
	P10–P17	I/O	8-bit \times 1 (CMOS input/output structure, however, N-channel open-drain output structure, when P11–P14 are used as multi-master I ² C-BUS interface, can be used as OSD output pin, A-D input pins, INT input pin, multi-master I ² C-BUS interface)
	P20–P27	I/O	8-bit \times 1 (P2 is CMOS input/output structure, however, N-channel open-drain output structure when P20 and 21 are used as serial output, can be used as serial input/output pins, timer external clock input pins, OSD clock input/output pin, sub-clock input/output pins)
	P30, P31	I/O	2-bit \times 1 (CMOS input/output or N-channel open-drain output structure, can be used as A-D input pins)
	P50, P51	Input	2-bit \times 1 (can be used as OSD input pins)
	P52–P55	Output	4-bit \times 1 (CMOS output structure, can be used as OSD output pins)
Serial I/O		8-bit \times 1	
Multi-master I ² C-BUS interface		1 (2 systems)	
A-D comparator		6 channels (6-bit resolution)	
PWM output circuit		8-bit \times 6	
Timers		8-bit timer \times 6	
ROM correction function		2 vectors	
Subroutine nesting		128 levels (maximum)	
Interrupt		<17 types> INT external interrupt \times 3, Internal timer interrupt \times 6, Serial I/O interrupt \times 1, OSD interrupt \times 1, Multi-master I ² C-BUS interface interrupt \times 1, Data slicer interrupt \times 1, f(XIN)/4096 interrupt \times 1, VSYNC interrupt \times 1, BRK instruction interrupt \times 1, reset \times 1	
Clock generating circuit		2 built-in circuits (externally connected to a ceramic resonator or a quartz-crystal oscillator)	
Data slicer		Built-in	

M37272M6H/M8H/MAH/MFH-XXXSP/FP
M37272E8SP/FP, M37272EFSP/FP

SINGLE-CHIP 8-BIT CMOS MICROCOMPUTER with CLOSED CAPTION DECODER
 and ON-SCREEN DISPLAY CONTROLLER

Table 6.2 Performance Overview (Continued)

Parameter			Functions	
OSD function	Number of display characters		32 characters X 2 lines	
	Dot structure		CC mode: 16 X 26 dots (character display area : 16 X 20 dots) OSD mode: 16 X 20 dots	
	Kinds of characters		254 kinds	
	Kinds of character sizes 1 screen : 8		CC mode: 1 kinds OSD mode: 8 kinds	
	Character font coloring		1 screen: 8 kinds (per character unit)	
	Display position		Horizontal: 128 levels, Vertical: 512 levels	
Power source voltage			5V ± 10%	
Power dissipation	In high-speed mode	OSD ON	Data slicer ON	165 mW typ. (at oscillation frequency $f(X_{IN}) = 8$ MHz, $f_{OSC} = 27$ MHz)
		OSD OFF	Data slicer OFF	82.5 mW typ. (at oscillation frequency $f(X_{IN}) = 8$ MHz)
	In low-speed mode	OSD OFF	Data slicer OFF	0.33 mW typ. (at oscillation frequency $f(X_{CIN}) = 32$ kHz, $f(X_{IN}) =$ stopped)
		In stop mode		0.055 mW (maximum)
Operating temperature range			-10 °C to 70 °C	
Device structure			CMOS silicon gate process	
Package			42-pin plastic molded DIP	
			42-pin plastic molded SSOP	

M37272M6H/M8H/MAH/MFH-XXXSP/FP M37272E8SP/FP, M37272EFSP/FP

SINGLE-CHIP 8-BIT CMOS MICROCOMPUTER with CLOSED CAPTION DECODER
and ON-SCREEN DISPLAY CONTROLLER

7. PIN DESCRIPTION

Table 7.1 Pin Description

Pin	Name	Input/ Output	Functions
Vcc, (AVcc), Vss	Power source		Apply voltage of 5 V ± 10 % to (typical) VCC , and 0 V to Vss. When use M37272E8SP/FP, M37272EFSP/FP, apply voltage of 5 V ± 10 % to (typical) AVcc.
CNVss	CNVss		This is connected to Vss.
RESET	Reset input	Input	To enter the reset state, the reset input pin must be kept at a LOW for 2 μs or more (under normal Vcc conditions). If more time is needed for the quartz-crystal oscillator to stabilize, this LOW condition should be maintained for the required time.
XIN	Clock input	Input	This chip has an internal clock generating circuit. To control generating frequency, an external ceramic resonator or a quartz-crystal oscillator is connected between pins XIN and XOUT. If an external clock is used, the clock source should be connected to the XIN pin and the XOUT pin should be left open.
XOUT	Clock output	Output	
P00/PWM0- P05/PWM5, P06/INT2/AD4, P07/INT1	I/O port P0	I/O	Port P0 is an 8-bit I/O port with direction register allowing each I/O bit to be individually programmed as input or output. At reset, this port is set to input mode. The output structure is N-channel open-drain output. (See note 1)
	PWM output	Output	Pins P00–P05 are also used as PWM output pins PWM0–PWM5 respectively. The output structure is N-channel open-drain output.
	External interrupt input	Input	Pins P06 and P07 are also used as INT external interrupt input pins INT2 and INT1 respectively.
	Analog input	Input	P06 pin is also used as analog input pin AD4.
P10/OUT2, P11/SCL1, P12/SCL2, P13/SDA1, P14/SDA2, P15/AD1/INT3, P16/AD2, P17/AD3	I/O port P1	I/O	Port P1 is an 8-bit I/O port and has basically the same functions as port P0. The output structure is CMOS output. (See note 1)
	OSD output	Output	Pins P10 is also used as OSD output pin OUT2. The output structure is CMOS output.
	Multi-master I ² C-BUS interface	I/O	Pins P11–P14 are used as SCL1, SCL2, SDA1 and SDA2 respectively, when multi-master I ² C-BUS interface is used. The output structure is N-channel open-drain output.
	Analog input	Input	Pins P10, P15–P17 are also used as analog input pin AD8, AD1–AD3 respectively.
P20/SCLK, P21/SOUT, P22/SIN, P23/TIM3, P24/TIM2, P25, P26/OSC1/ XCIN, P27/OSC2/ XCOUT	I/O port P2	I/O	Port P2 is an 8-bit I/O port and has basically the same functions as port P0. The output structure is CMOS output. (See note 1)
	Serial I/O synchronous clock input/output port	I/O	P20 pin is also used as serial I/O synchronous clock input/output pin SCLK. The output structure is N-channel open-drain output.
	Serial I/O data output	I/O	P21 pin is also used as serial I/O data output pin SOUT. The output structure is open-drain output.
	Serial I/O data input	Input	P22 pin is also used as serial I/O data input pin SIN.
	External clock input for timer	Input	Pins P23 and P24 are also used as timer external clock input pins TIM3 and TIM2 respectively.
	Clock input for OSD	Input	P26 pin is also used as OSD clock input pin OSC1. (See note 2)
	Clock output for OSD	Output	P27 pin is also used as OSD clock input pin OSC2. The output structure is CMOS output. (See note 2)
	Sub-clock input	Input	P26 pin is also used as sub-clock input pin XCIN.
Sub-clock output	Output	P27 pin is also used as sub-clock output pin XCOUT.	

M37272M6H/M8H/MAH/MFH-XXXSP/FP
M37272E8SP/FP, M37272EFSP/FP

SINGLE-CHIP 8-BIT CMOS MICROCOMPUTER with CLOSED CAPTION DECODER
 and ON-SCREEN DISPLAY CONTROLLER

Table 7.2 Pin Description (continued)

Pin	Name	Input/ Output	Functions
P30/AD5, P31/AD6	I/O port P3	I/O	Ports P30 and P31 are a 2-bit I/O port and has basically the same functions as port 0. The output structure can be selected either CMOS output or N-channel open-drain output structure. (See notes 1, 3)
	Analog input	Input	Pins P30 and P31 are also used as analog input pins AD5 and AD6 respectively.
P50/HSYNC, P51/VSYNC	Input port P5	Input	Pin P50 and P51 are 2-bit input ports.
	HSYNC input	Input	Pin P50 is also used as HSYNC input. This is a horizontal synchronous signal input for OSD.
	VSYNC input	Input	Pin P51 is also used as VSYNC input. This is a vertical synchronous signal input for OSD.
P52/R, P53/G, P54/B, P55/OUT1	Output port P5	Output	Ports P52–P55 are a 4-bit output port. The output structure is CMOS output.
	OSD output	Output	Pins P52–P55 are also used as OSD output pins R, G, B, OUT1 respectively. The output structure is CMOS output.
CVIN	I/O for data slicer	Input	Input composite video signal through a capacitor.
VHOLD		Input	Connect a capacitor between VHOLD and Vss.
HLF		I/O	Connect a filter using of a capacitor and a resistor between HLF and Vss.

Notes 1: Port Pi (i = 0 to 3) has the port Pi direction register which can be used to program each bit as an input ("0") or an output ("1"). The pins programmed as "1" in the direction register are output pins. When pins are programmed as "0," they are input pins. When pins are programmed as output pins, the output data are written into the port latch and then output. When data is read from the output pins, the output pin level is not read but the data of the port latch is read. This allows a previously-output value to be read correctly even if the output LOW voltage has risen, for example, because a light emitting diode was directly driven. The input pins are in the floating state, so the values of the pins can be read. When data is written into the input pin, it is written only into the port latch, while the pin remains in the floating state.

2: To switch output functions, set the raster color register and OSD control register. When pins P26 and P27 are used as the OSD clock input/output pins, set the corresponding bits of the port P2 direction register to "0" (input mode).

3: To switch output structures, set bits 2 and 3 of the port P3 direction register, When "0," CMOS output ; when "1," N-channel open-drain output.

M37272M6H/M8H/MAH/MFH-XXXSP/FP M37272E8SP/FP, M37272EFSP/FP

SINGLE-CHIP 8-BIT CMOS MICROCOMPUTER with CLOSED CAPTION DECODER
and ON-SCREEN DISPLAY CONTROLLER

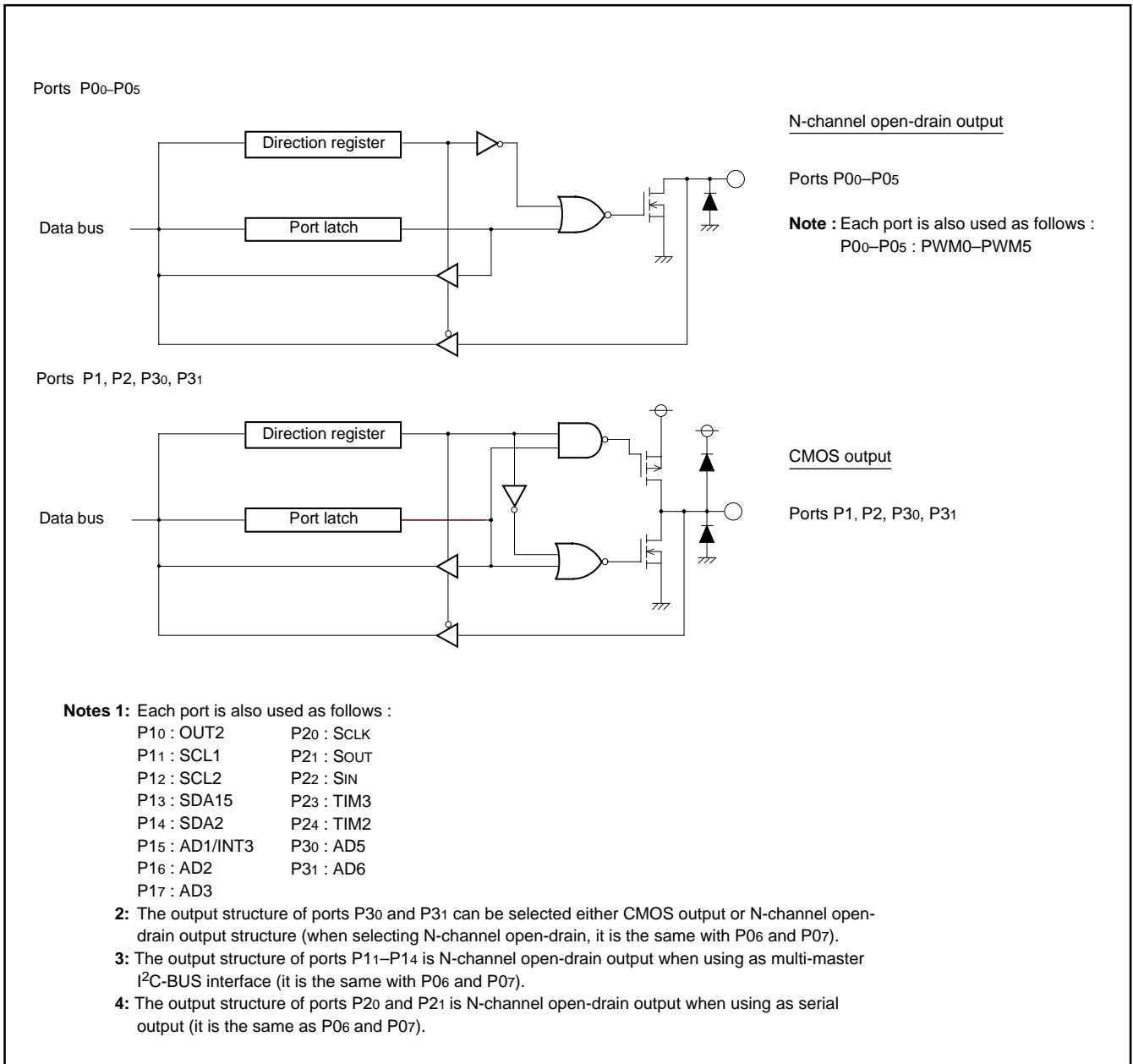

Fig. 7.1 I/O Pin Block Diagram (1)

M37272M6H/M8H/MAH/MFH-XXXSP/FP
M37272E8SP/FP, M37272EFSP/FP

SINGLE-CHIP 8-BIT CMOS MICROCOMPUTER with CLOSED CAPTION DECODER
 and ON-SCREEN DISPLAY CONTROLLER

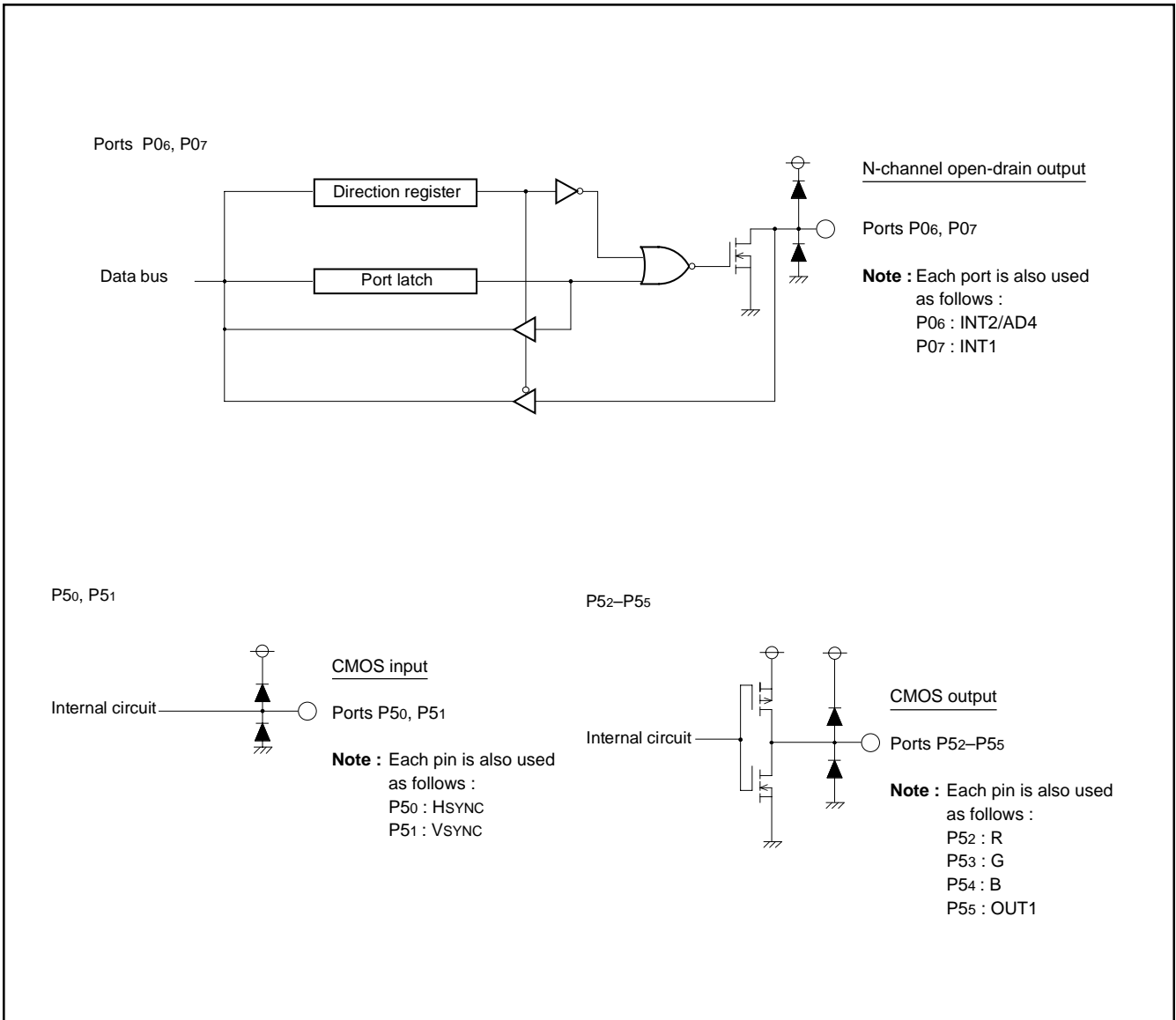

Fig. 7.2 I/O Pin Block Diagram (2)

M37272M6H/M8H/MAH/MFH-XXXSP/FP M37272E8SP/FP, M37272EFSP/FP

SINGLE-CHIP 8-BIT CMOS MICROCOMPUTER with CLOSED CAPTION DECODER
and ON-SCREEN DISPLAY CONTROLLER

8. FUNCTIONAL DESCRIPTION

8.1 CENTRAL PROCESSING UNIT (CPU)

This microcomputer uses the standard 740 Family instruction set. Refer to the table of 740 Family addressing modes and machine instructions or the SERIES 740 <Software> User's Manual for details on the instruction set.

Machine-resident 740 Family instructions are as follows:

The FST, SLW instruction cannot be used.

The MUL, DIV, WIT and STP instructions can be used.

8.1.1 CPU Mode Register

The CPU mode register contains the stack page selection bit and internal system clock selection bit. The CPU mode register is allocated at address 00FB16.

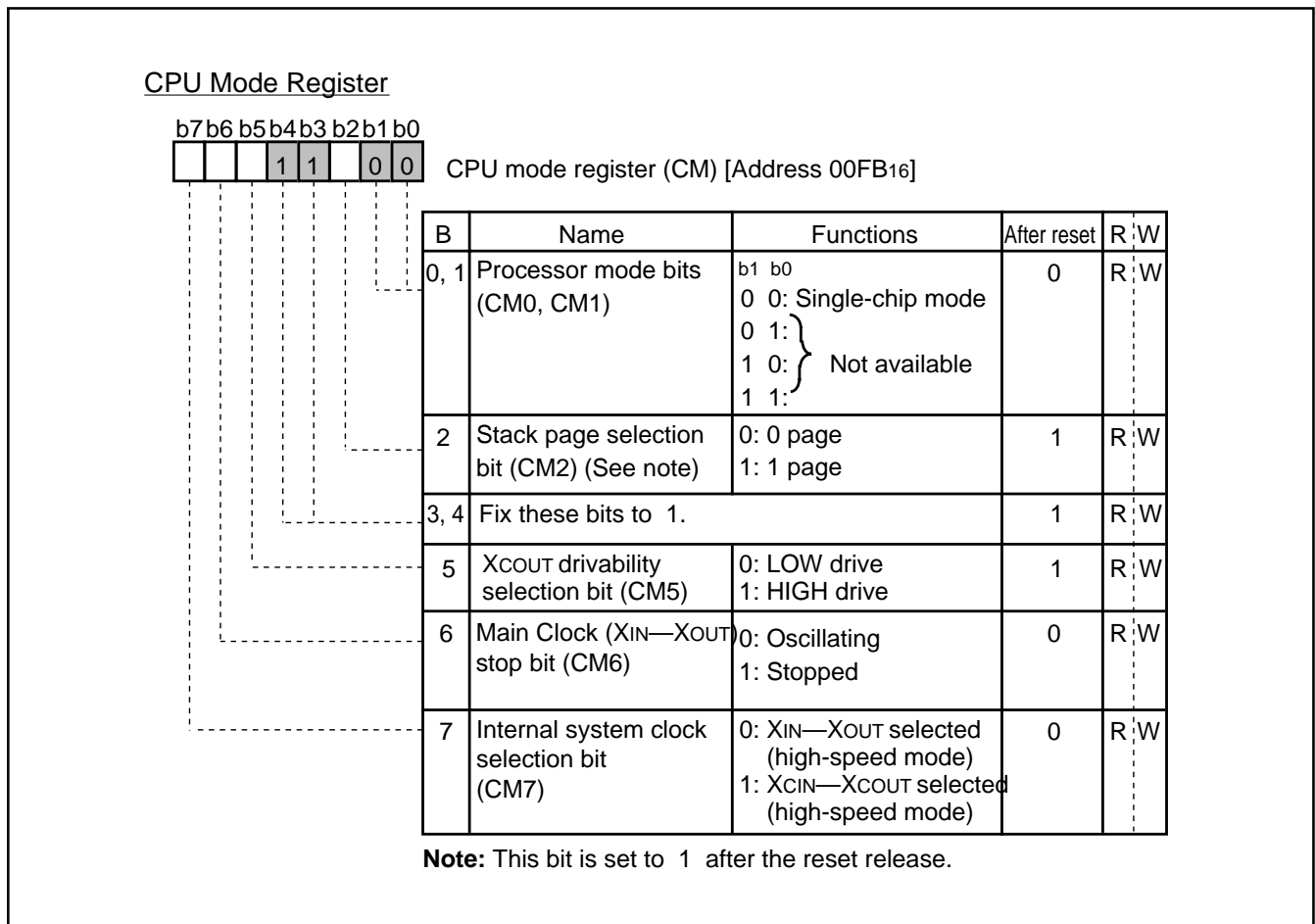

Fig. 8.1.1 CPU Mode Register

M37272M6H/M8H/MAH/MFH-XXXSP/FP M37272E8SP/FP, M37272EFSP/FP

SINGLE-CHIP 8-BIT CMOS MICROCOMPUTER with CLOSED CAPTION DECODER
and ON-SCREEN DISPLAY CONTROLLER

8.2 MEMORY

8.2.1 Special Function Register (SFR) Area

The special function register (SFR) area in the zero page contains control registers such as I/O ports and timers.

8.2.2 RAM

RAM is used for data storage and for stack area of subroutine calls and interrupts.

8.2.3 ROM

ROM is used for storing user programs as well as the interrupt vector area.

8.2.4 OSD RAM

RAM for display is used for specifying the character codes and colors to display.

8.2.5 OSD ROM

ROM for display is used for storing character data.

8.2.6 Interrupt Vector Area

The interrupt vector area contains reset and interrupt vectors.

8.2.7 Zero Page

The 256 bytes from addresses 0000₁₆ to 00FF₁₆ are called the zero page area. The internal RAM and the special function registers (SFR) are allocated to this area.

The zero page addressing mode can be used to specify memory and register addresses in the zero page area. Access to this area with only 2 bytes is possible in the zero page addressing mode.

8.2.8 Special Page

The 256 bytes from addresses FF00₁₆ to FFFF₁₆ are called the special page area. The special page addressing mode can be used to specify memory addresses in the special page area. Access to this area with only 2 bytes is possible in the special page addressing mode.

8.2.9 ROM Correction Memory (RAM)

This is used as the program area for ROM correction.

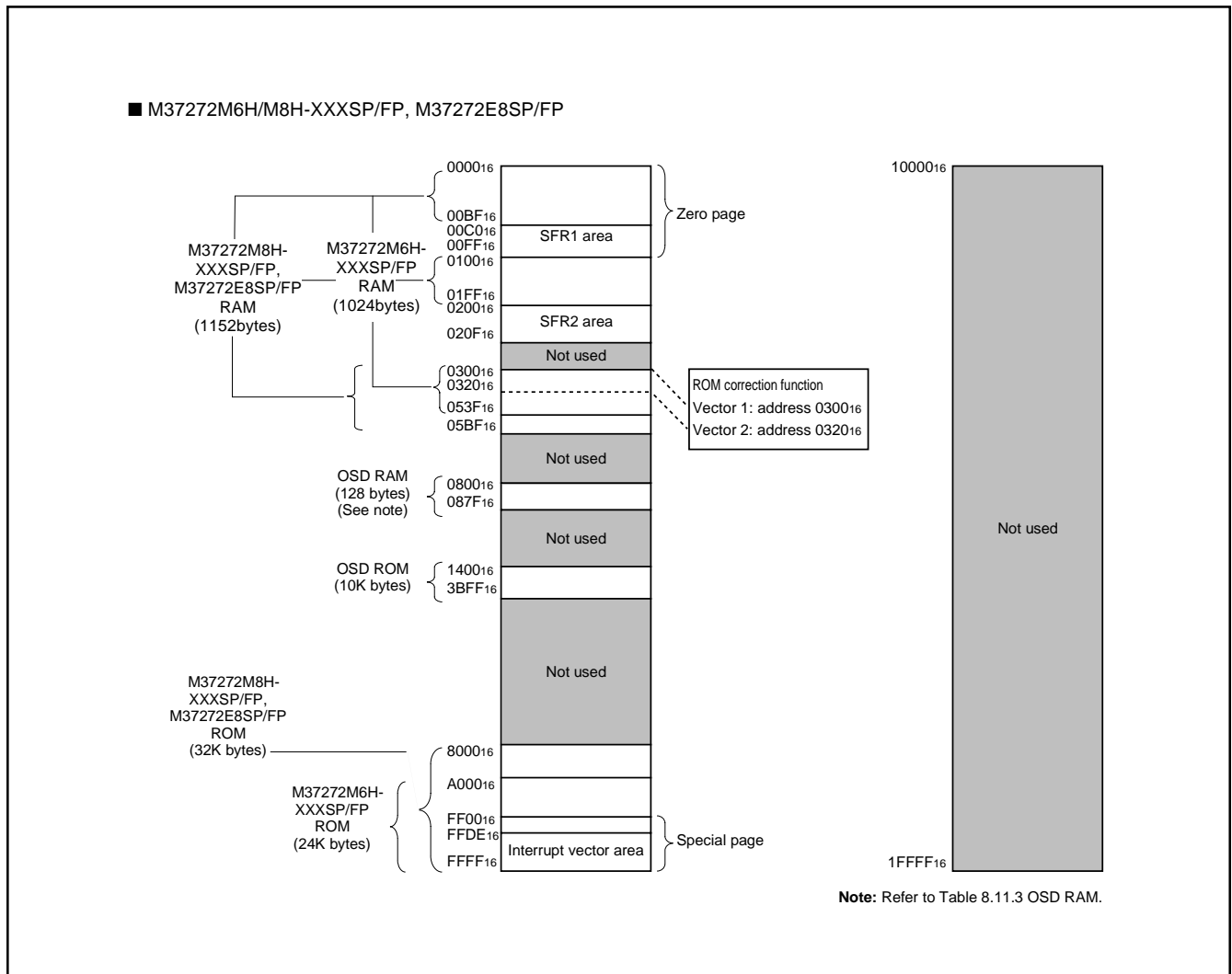

Fig. 8.2.1 Memory Map (M37272M6H/M8H-XXXSP/FP, M37272E8SP/FP)

M37272M6H/M8H/MAH/MFH-XXXSP/FP M37272E8SP/FP, M37272EFSP/FP

SINGLE-CHIP 8-BIT CMOS MICROCOMPUTER with CLOSED CAPTION DECODER
and ON-SCREEN DISPLAY CONTROLLER

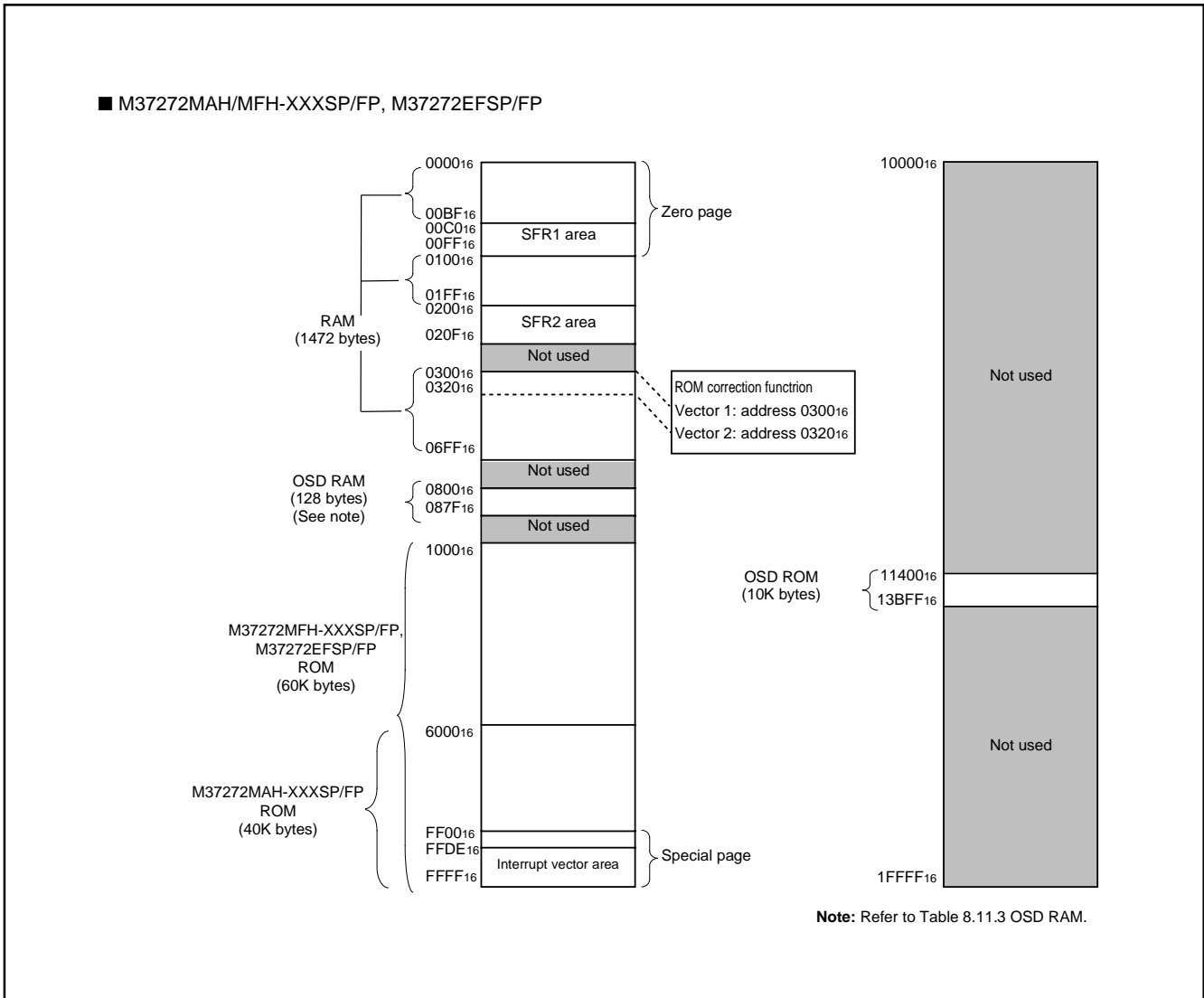

Fig. 8.2.2 Memory Map (M37272MAH/MFH-XXXSP/FP, M37272EFSP/FP)

M37272M6H/M8H/MAH/MFH-XXXSP/FP
M37272E8SP/FP, M37272EFSP/FP

SINGLE-CHIP 8-BIT CMOS MICROCOMPUTER with CLOSED CAPTION DECODER
 and ON-SCREEN DISPLAY CONTROLLER

		<Bit allocation>		<State immediately after reset>	
		<input type="checkbox"/>	: Function bit	<input type="checkbox"/> 0	: "0" immediately after reset
		<input type="checkbox"/>	: No function bit	<input type="checkbox"/> 1	: "1" immediately after reset
		<input checked="" type="checkbox"/> 0	: Fix this bit to "0" (do not write "1")	<input type="checkbox"/> ?	: Indeterminate immediately after reset
		<input checked="" type="checkbox"/> 1	: Fix this bit to "1" (do not write "0")		

Address	Register	Bit allocation		State immediately after reset	
		b7	b0	b7	b0
C0 ₁₆	Port P0 (P0)			?	
C1 ₁₆	Port P0 direction register (D0)			00 ₁₆	
C2 ₁₆	Port P1 (P1)			?	
C3 ₁₆	Port P1 direction register (D1)			00 ₁₆	
C4 ₁₆	Port P2 (P2)			?	
C5 ₁₆	Port P2 direction register (D2)			00 ₁₆	
C6 ₁₆	Port P3 (P3)		P31 P30	0	0 0 0 ? ?
C7 ₁₆	Port P3 direction register (D3)	T3SC	P31C P30C P31D P30D	00 ₁₆	
C8 ₁₆				?	
C9 ₁₆				?	
CA ₁₆	Port P5 (P5)			?	
CB ₁₆	OSD port control register (PF)	PF7	PF5 PF4 PF3 PF2	0	0
CC ₁₆		00 ₁₆		00 ₁₆	
CD ₁₆				?	
CE ₁₆	Caption data register 3 (CD3)	CDL27 CDL26 CDL25 CDL24	CDL23 CDL22 CDL21 CDL20	?	
CF ₁₆	Caption data register 4 (CD4)	CDH27 CDH26 CDH25 CDH24	CDH23 CDH22 CDH21 CDH20	?	
D0 ₁₆	OSD control register (OC)	0	OC6 OC5 OC4 OC3 OC2 OC1 OC0	00 ₁₆	
D1 ₁₆	Horizontal position register (HP)	HP6	HP5 HP4 HP3 HP2 HP1 HP0	00 ₁₆	
D2 ₁₆	Block control register 1 (BC1)	BC17 BC16	BC15 BC14 BC13 BC12 BC11 BC10	?	
D3 ₁₆	Block control register 2 (BC2)	BC27 BC26	BC25 BC24 BC23 BC22 BC21 BC20	?	
D4 ₁₆	Vertical position register 1 (VP1)	VP17 VP16	VP15 VP14 VP13 VP12 VP11 VP10	?	
D5 ₁₆	Vertical position register 2 (VP2)	VP27 VP26	VP25 VP24 VP23 VP22 VP21 VP20	?	
D6 ₁₆	Window register 1 (WN1)	WN17 WN16	WN15 WN14 WN13 WN12 WN11 WN10	?	
D7 ₁₆	Window register 2 (WN2)	WN27 WN26	WN25 WN24 WN23 WN22 WN21 WN20	?	
D8 ₁₆	I/O polarity control register (PC)	0	PC6 PC5 PC4 PC3 PC2 PC1 PC0	40 ₁₆	
D9 ₁₆	Raster color register (RC)	RC7	0 RC4 RC3 RC2 RC1 RC0	00 ₁₆	
DA ₁₆				?	
DB ₁₆				?	
DC ₁₆	Interrupt input polarity control register (RE)		INT3 INT2 INT1	00 ₁₆	
DD ₁₆		00 ₁₆		00 ₁₆	
DE ₁₆		00 ₁₆		00 ₁₆	
DF ₁₆		00 ₁₆ (See note 1)		00 ₁₆ (See note 2)	

Notes 1: This is only M37272MAH/MFH-XXXSP/FP, M37272EFSP/FP.
 2: As for M37272M6H/M8H-XXXSP/FP and M37272E8SP/FP, the reset value is ? (indeterminate).

Fig. 8.2.3 Memory Map of Special Function Register 1 (SFR1) (1)

M37272M6H/M8H/MAH/MFH-XXXSP/FP M37272E8SP/FP, M37272EFSP/FP

SINGLE-CHIP 8-BIT CMOS MICROCOMPUTER with CLOSED CAPTION DECODER
and ON-SCREEN DISPLAY CONTROLLER

■ SFR1 Area (addresses E0₁₆ to FF₁₆)

<Bit allocation>

- : } Function bit
- Name : }
- : No function bit
- 0 : Fix this bit to "0"
(do not write "1")
- 1 : Fix this bit to "1"
(do not write "0")

<State immediately after reset>

- 0 : "0" immediately after reset
- 1 : "1" immediately after reset
- ? : Indeterminate immediately after reset

Address	Register	Bit allocation								State immediately after reset								
		b7						b0		b7						b0		
E0 ₁₆	Data slicer control register 1 (DSC1)	0	1	1	0	0	DSC12	DSC11	DSC10									00 ₁₆
E1 ₁₆	Data slicer control register 2 (DSC2)		0				DSC25	DSC24	DSC23			1						? 0 ? 0 ? ? 0 ?
E2 ₁₆	Caption data register 1 (CD1)	CDL17	CDL16	CDL15	CDL14	CDL13	CDL12	CDL11	CDL10									00 ₁₆
E3 ₁₆	Caption data register 2 (CD2)	CDH17	CDH16	CDH15	CDH14	CDH13	CDH12	CDH11	CDH10									00 ₁₆
E4 ₁₆	Clock run-in detect register (CRD)	CRD7	CRD6	CRD5	CRD4	CRD3												00 ₁₆
E5 ₁₆	Data clock position register (DPS)	DPS7	DPS6	DPS5	DPS4	DPS3	0	1	0									09 ₁₆
E6 ₁₆	Caption position register (CPS)	CPS7	CPS6	CPS5	CPS4	CPS3	CPS2	CPS1	CPS0									0 0 ? 0 0 0 0 0
E7 ₁₆	Data slicer test register 2																	00 ₁₆
E8 ₁₆	Data slicer test register 1																	00 ₁₆
E9 ₁₆	Synchronous signal counter register			HC5	HC4	HC3	HC2	HC1	HC0									00 ₁₆
EA ₁₆	Serial I/O register (SIO)																	?
EB ₁₆	Serial I/O mode register (SM)	0	SM6	SM5	0	SM3	SM2	SM1	SM0									00 ₁₆
EC ₁₆	A-D control register 1 (AD1)				ADC14		ADC12	ADC11	ADC10									0 0 0 ? 0 0 0 0
ED ₁₆	A-D control register 2 (AD2)				ADC25	ADC24	ADC23	ADC22	ADC21	ADC20								00 ₁₆
EE ₁₆	Timer 5 (T5)																	07 ₁₆
EF ₁₆	Timer 6 (T6)																	FF ₁₆
F0 ₁₆	Timer 1 (T1)																	FF ₁₆
F1 ₁₆	Timer 2 (T2)																	07 ₁₆
F2 ₁₆	Timer 3 (T3)																	FF ₁₆
F3 ₁₆	Timer 4 (T4)																	07 ₁₆
F4 ₁₆	Timer mode register 1 (TM1)	TM17	TM16	TM15	TM14	TM13	TM12	TM11	TM10									00 ₁₆
F5 ₁₆	Timer mode register 2 (TM2)	TM27	TM26	TM25	TM24	TM23	TM22	TM21	TM20									00 ₁₆
F6 ₁₆	I ² C data shift register (S0)	D7	D6	D5	D4	D3	D2	D1	D0									?
F7 ₁₆	I ² C address register (S0D)	SAD6	SAD5	SAD4	SAD3	SAD2	SAD1	SAD0	RBW									00 ₁₆
F8 ₁₆	I ² C status register (S1)	MST	TRX	BB	PIN	AL	AAS	AD0	LRB									0 0 0 1 0 0 0 ?
F9 ₁₆	I ² C control register (S1D)	BSEL1	BSEL0	¹⁰ BIT SAD	ALS	ESO	BC2	BC1	BC0									00 ₁₆
FA ₁₆	I ² C clock control register (S2)	ACK BIT	ACK MODE	FAST MODE	CCR4	CCR3	CCR2	CCR1	CCR0									00 ₁₆
FB ₁₆	CPU mode register (CPUM)	CM7	CM6	CM5	1	1	CM2	0	0									3C ₁₆
FC ₁₆	Interrupt request register 1 (IREQ1)		IN3R	VSCR	OSDR	TM4R	TM3R	TM2R	TM1R									00 ₁₆
FD ₁₆	Interrupt request register 2 (IREQ2)	0	TM56R	RICR	IN2R	CKR	S1R	DSR	IN1R									00 ₁₆
FE ₁₆	Interrupt control register 1 (ICON1)		IN3E	VSCOE	OSDE	TM4E	TM3E	TM2E	TM1E									00 ₁₆
FF ₁₆	Interrupt control register 2 (ICON2)	TM56C	TM56E	IICE	IN2E	CKE	S1E	DSE	IN1E									00 ₁₆

Fig. 8.2.4 Memory Map of Special Function Register 1 (SFR1) (2)

M37272M6H/M8H/MAH/MFH-XXXSP/FP M37272E8SP/FP, M37272EFSP/FP

SINGLE-CHIP 8-BIT CMOS MICROCOMPUTER with CLOSED CAPTION DECODER
and ON-SCREEN DISPLAY CONTROLLER

■ SFR2 Area (addresses 200₁₆ to 20F₁₆)

<Bit allocation>

: } Function bit
Name : }

: No function bit

0 : Fix this bit to "0"
(do not write "1")

1 : Fix this bit to "1"
(do not write "0")

<State immediately after reset>

0 : "0" immediately after reset

1 : "1" immediately after reset

? : Indeterminate immediately
after reset

Address	Register	Bit allocation								State immediately after reset							
		b7						b0	b7	b7						b0	
200 ₁₆	PWM0 register (PWM0)																?
201 ₁₆	PWM1 register (PWM1)																?
202 ₁₆	PWM2 register (PWM2)																?
203 ₁₆	PWM3 register (PWM3)																?
204 ₁₆	PWM4 register (PWM4)																?
205 ₁₆	PWM5 register (PWM5)																?
206 ₁₆		00 ₁₆								?							
207 ₁₆		00 ₁₆								?							
208 ₁₆	PWM mode register 1 (PM1)						PM13								PM10		?
209 ₁₆	PWM mode register 2 (PM2)	0	0	PM25	PM24	PM23	PM22	PM21	PM20								00 ₁₆
20A ₁₆	ROM correction address 1 (high-order)									00 ₁₆							
20B ₁₆	ROM correction address 1 (low-order)									00 ₁₆							
20C ₁₆	ROM correction address 2 (high-order)									00 ₁₆							
20D ₁₆	ROM correction address 2 (low-order)									00 ₁₆							
20E ₁₆	ROM correction enable register (RCR)														RC1	RC0	00 ₁₆
20F ₁₆										?							

Fig. 8.2.5 Memory Map of Special Function Register 2 (SFR2)

M37272M6H/M8H/MAH/MFH-XXXSP/FP
M37272E8SP/FP, M37272EFSP/FP

SINGLE-CHIP 8-BIT CMOS MICROCOMPUTER with CLOSED CAPTION DECODER
 and ON-SCREEN DISPLAY CONTROLLER

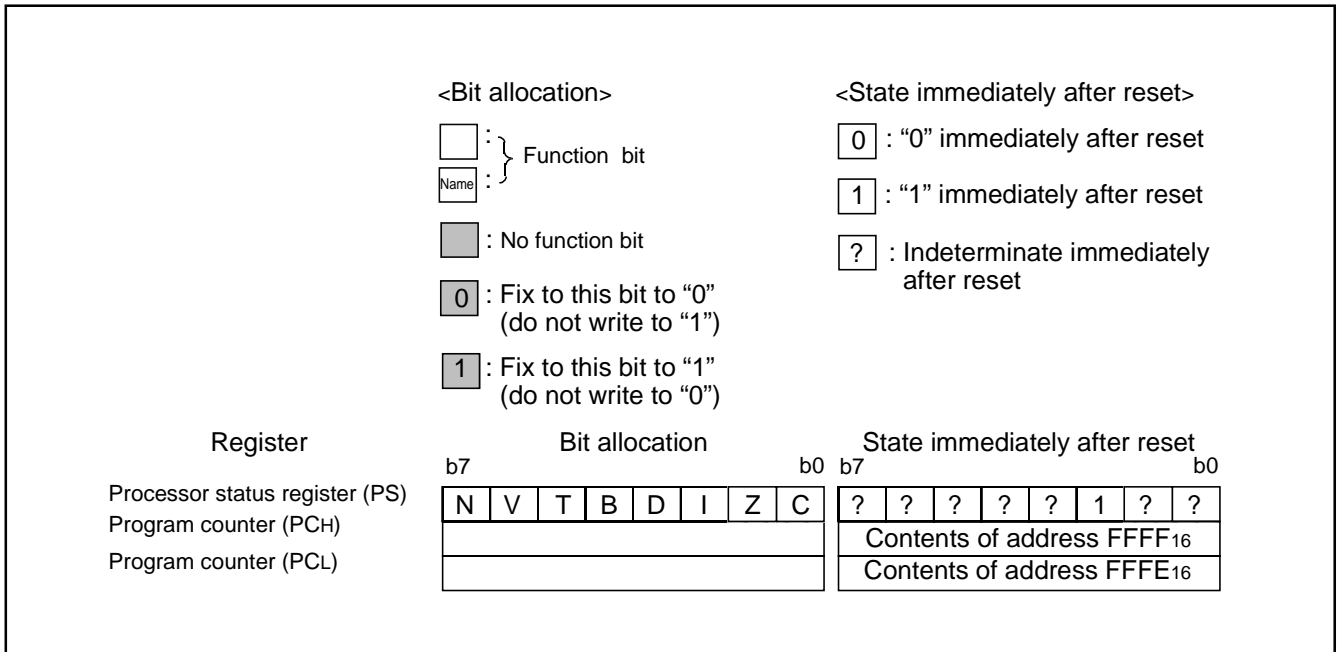

Fig. 8.2.6 Internal State of Processor Status Register and Program Counter at Reset

M37272M6H/M8H/MAH/MFH-XXXSP/FP M37272E8SP/FP, M37272EFSP/FP

SINGLE-CHIP 8-BIT CMOS MICROCOMPUTER with CLOSED CAPTION DECODER
and ON-SCREEN DISPLAY CONTROLLER

8.3 INTERRUPTS

Interrupts can be caused by 17 different sources consisting of 4 external, 11 internal, 1 software, and reset. Interrupts are vectored interrupts with priorities as shown in Table 8.3.1. Reset is also included in the table because its operation is similar to an interrupt.

When an interrupt is accepted,

- ① The contents of the program counter and processor status register are automatically stored into the stack.
- ② The interrupt disable flag I is set to "1" and the corresponding interrupt request bit is set to "0."
- ③ The jump destination address stored in the vector address enters the program counter.

Other interrupts are disabled when the interrupt disable flag is set to "1."

All interrupts except the BRK instruction interrupt have an interrupt request bit and an interrupt enable bit. The interrupt request bits are in interrupt request registers 1 and 2 and the interrupt enable bits are in interrupt control registers 1 and 2. Figures 8.3.2 to 8.3.6 show the interrupt-related registers.

Interrupts other than the BRK instruction interrupt and reset are accepted when the interrupt enable bit is "1," interrupt request bit is "1," and the interrupt disable flag is "0." The interrupt request bit can be set to "0" by a program, but not set to "1." The interrupt enable bit can be set to "0" and "1" by a program.

Reset is treated as a non-maskable interrupt with the highest priority.

Figure 8.3.1 shows interrupt control.

8.3.1 Interrupt Causes

(1) VSYNC, OSD interrupts

The VSYNC interrupt is an interrupt request synchronized with the vertical sync signal.

The OSD interrupt occurs after character block display to the CRT is completed.

(2) INT1 to INT3 external interrupts

The INT1 to INT3 interrupts are external interrupt inputs, the system detects that the level of a pin changes from LOW to HIGH or from HIGH to LOW, and generates an interrupt request. The input active edge can be selected by bits 3 to 5 of the interrupt input polarity register (address 00DC16) : when this bit is "0," a change from LOW to HIGH is detected; when it is "1," a change from HIGH to LOW is detected. Note that both bits are cleared to "0" at reset.

(3) Timers 1 to 4 interrupts

An interrupt is generated by an overflow of timers 1 to 4.

Table 8.3.1 Interrupt Vector Addresses and Priority

Priority	Interrupt Source	Vector Addresses	Remarks
1	Reset	FFFF ₁₆ , FFFE ₁₆	Non-maskable
2	OSD interrupt	FFFD ₁₆ , FFFC ₁₆	
3	INT1 external interrupt	FFFB ₁₆ , FFFA ₁₆	Active edge selectable
4	Data slicer interrupt	FFF9 ₁₆ , FFF8 ₁₆	
5	Serial I/O interrupt	FFF7 ₁₆ , FFF6 ₁₆	
6	Timer 4 interrupt	FFF5 ₁₆ , FFF4 ₁₆	
7	f(XIN)/4096 interrupt	FFF3 ₁₆ , FFF2 ₁₆	
8	VSYNC interrupt	FFF1 ₁₆ , FFF0 ₁₆	
9	Timer 3 interrupt	FFEF ₁₆ , FFEE ₁₆	
10	Timer 2 interrupt	FFED ₁₆ , FFEC ₁₆	
11	Timer 1 interrupt	FFEB ₁₆ , FFEA ₁₆	
12	INT3 external interrupt	FFE9 ₁₆ , FFE8 ₁₆	Active edge selectable
13	INT2 external interrupt	FFE7 ₁₆ , FFE6 ₁₆	Active edge selectable
14	Multi-master I ² C-BUS interface interrupt	FFE5 ₁₆ , FFE4 ₁₆	
15	Timer 5 • 6 interrupt	FFE3 ₁₆ , FFE2 ₁₆	Source switch by software (see note)
16	BRK instruction interrupt	FFDF ₁₆ , FFDE ₁₆	Non-maskable

Note: Switching a source during a program causes an unnecessary interrupt. Therefore, set a source at initializing of program.

M37272M6H/M8H/MAH/MFH-XXXSP/FP
M37272E8SP/FP, M37272EFSP/FP

SINGLE-CHIP 8-BIT CMOS MICROCOMPUTER with CLOSED CAPTION DECODER
 and ON-SCREEN DISPLAY CONTROLLER

(4) Serial I/O interrupt

This is an interrupt request from the clock synchronous serial I/O function.

(5) f(XIN)/4096 interrupt

The f(XIN)/4096 interrupt occurs regularly with a f(XIN)/4096 period. Set bit 0 of the PWM mode register 1 to "0."

(6) Data slicer interrupt

An interrupt occurs when slicing data is completed.

(7) Multi-master I²C-BUS interface interrupt

This is an interrupt request related to the multi-master I²C-BUS interface.

(8) Timer 5 • 6 interrupt

An interrupt is generated by an overflow of timer 5 or 6. Their priorities are same, and can be switched by software.

(9) BRK instruction interrupt

This software interrupt has the least significant priority. It does not have a corresponding interrupt enable bit, and it is not affected by the interrupt disable flag I (non-maskable).

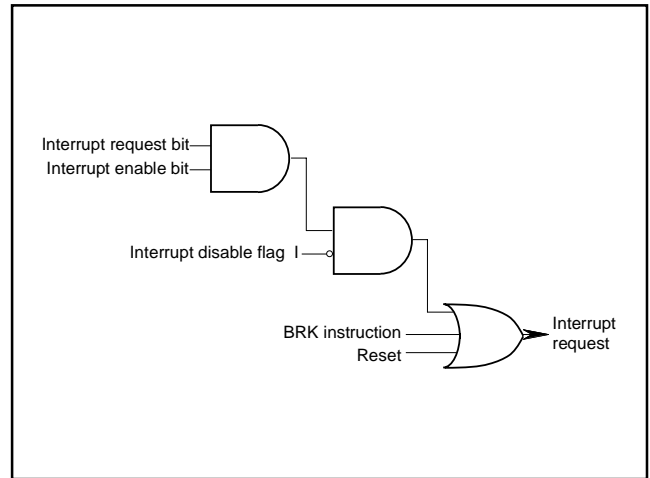

Fig. 8.3.1 Interrupt Control

M37272M6H/M8H/MAH/MFH-XXXSP/FP
M37272E8SP/FP, M37272EFSP/FP

SINGLE-CHIP 8-BIT CMOS MICROCOMPUTER with CLOSED CAPTION DECODER
 and ON-SCREEN DISPLAY CONTROLLER

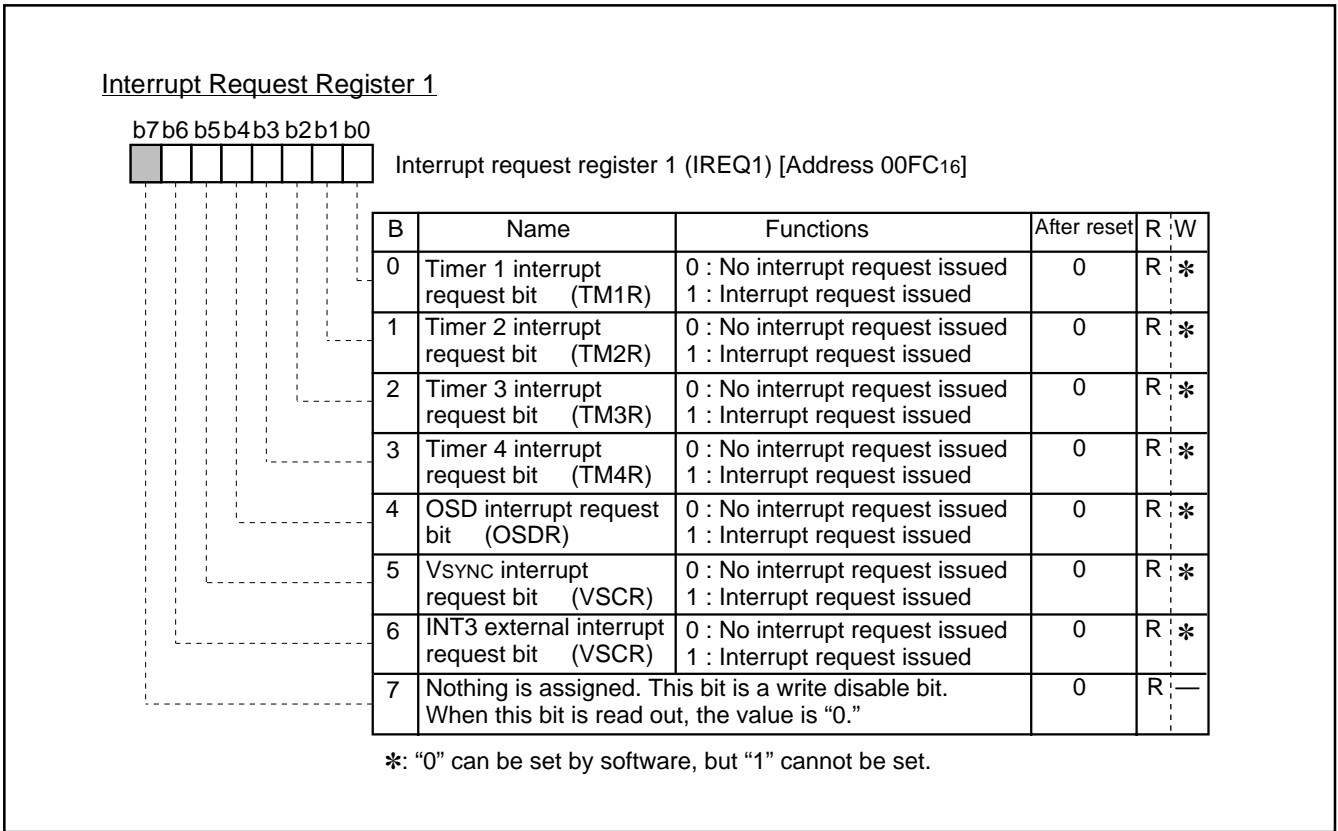

Fig. 8.3.2 Interrupt Request Register 1

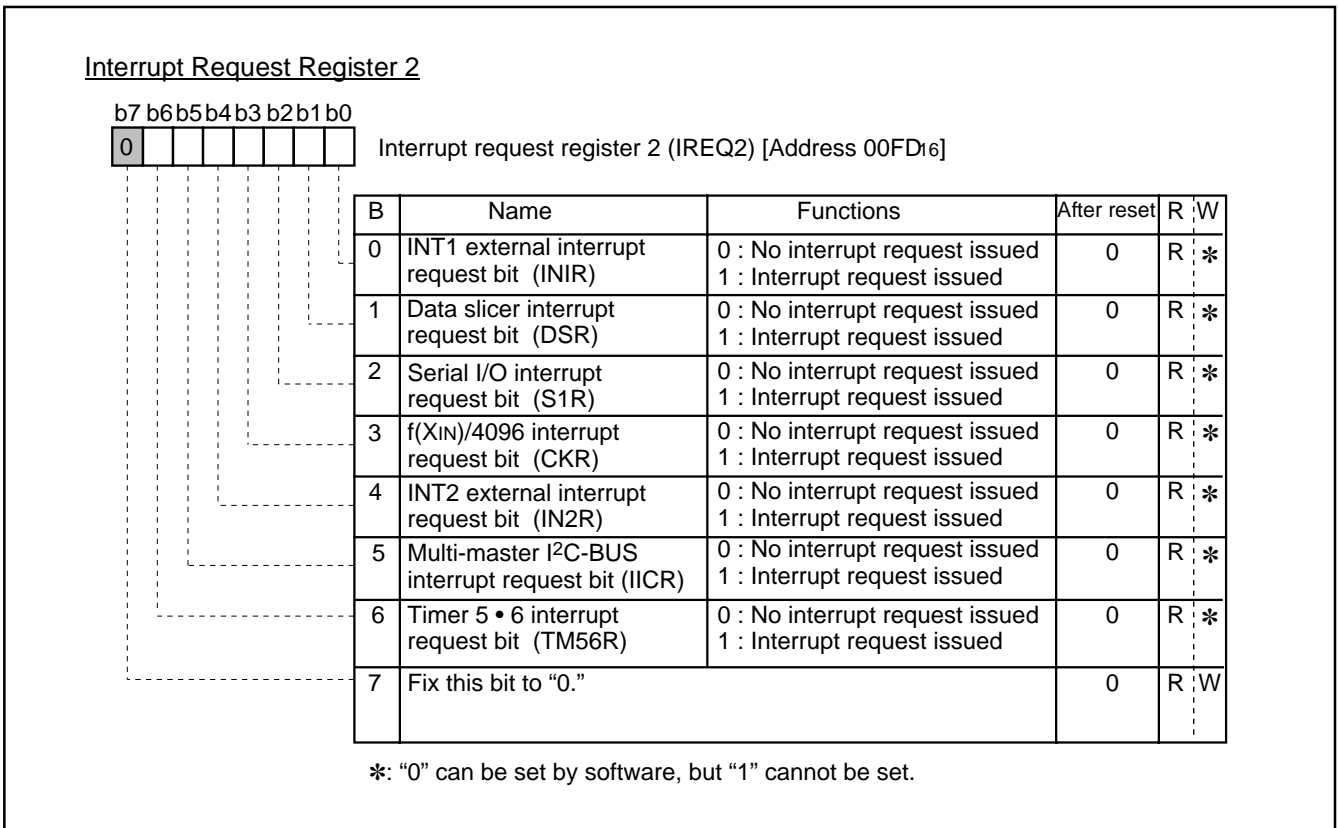

Fig. 8.3.3 Interrupt Request Register 2

M37272M6H/M8H/MAH/MFH-XXXSP/FP
M37272E8SP/FP, M37272EFSP/FP

SINGLE-CHIP 8-BIT CMOS MICROCOMPUTER with CLOSED CAPTION DECODER
 and ON-SCREEN DISPLAY CONTROLLER

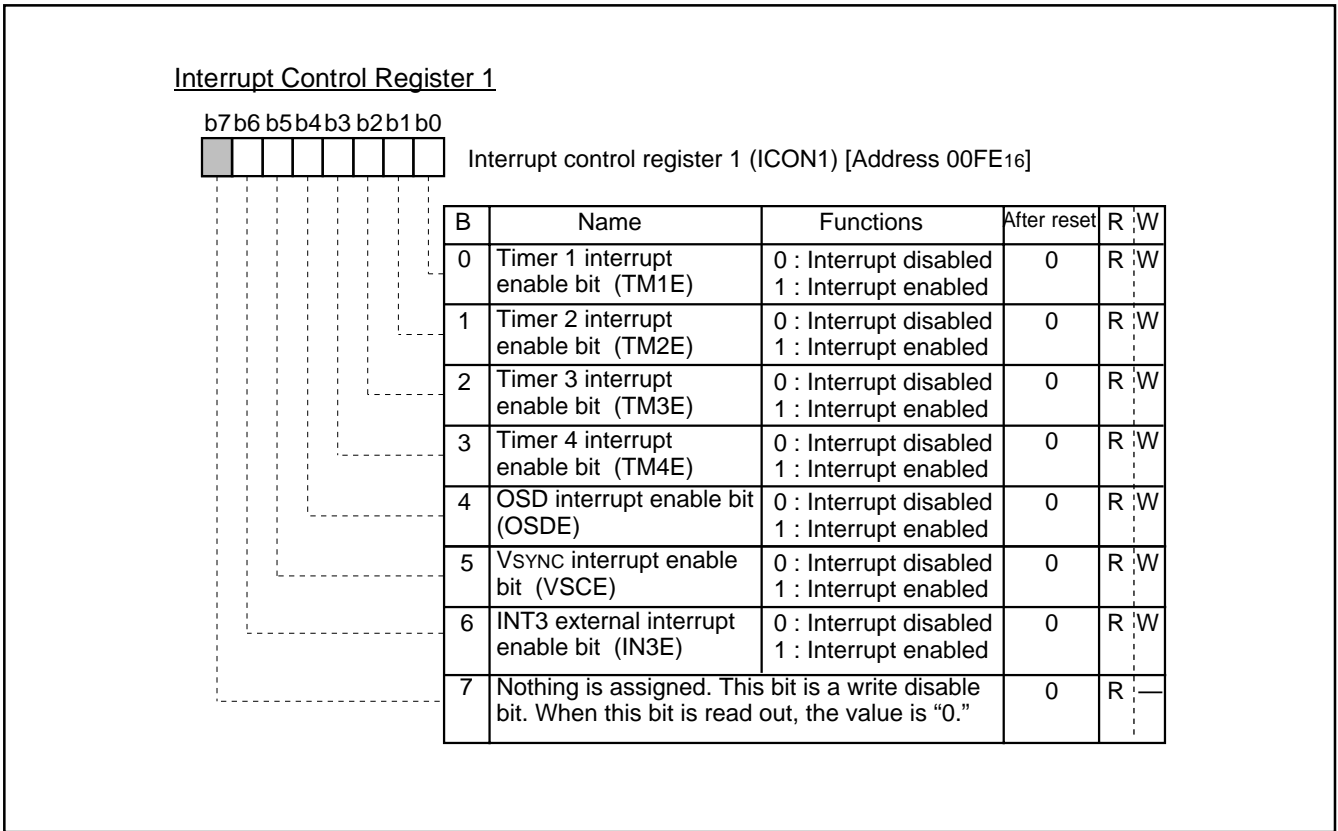

Fig. 8.3.4 Interrupt Control Register 1

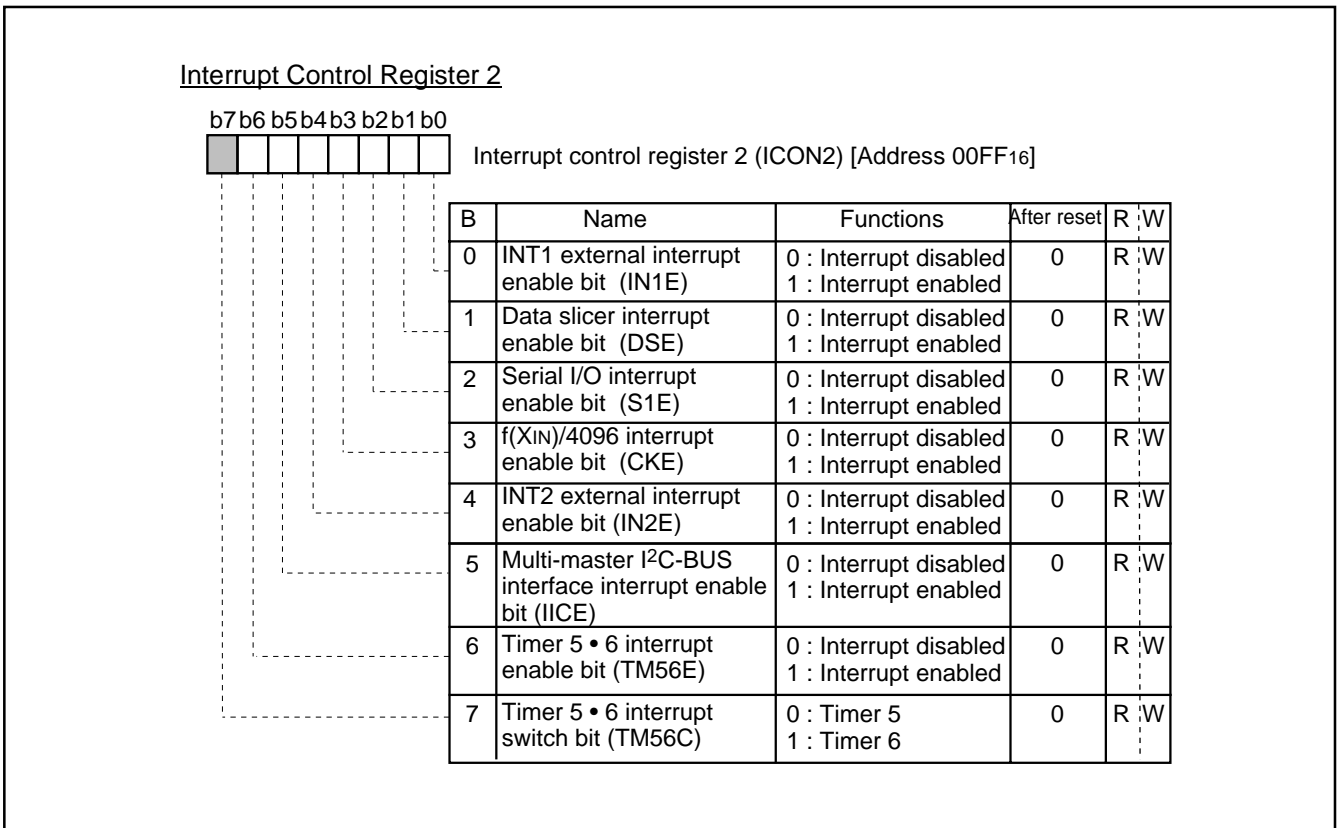

Fig. 8.3.5 Interrupt Control Register 2

M37272M6H/M8H/MAH/MFH-XXXSP/FP
M37272E8SP/FP, M37272EFSP/FP

SINGLE-CHIP 8-BIT CMOS MICROCOMPUTER with CLOSED CAPTION DECODER
 and ON-SCREEN DISPLAY CONTROLLER

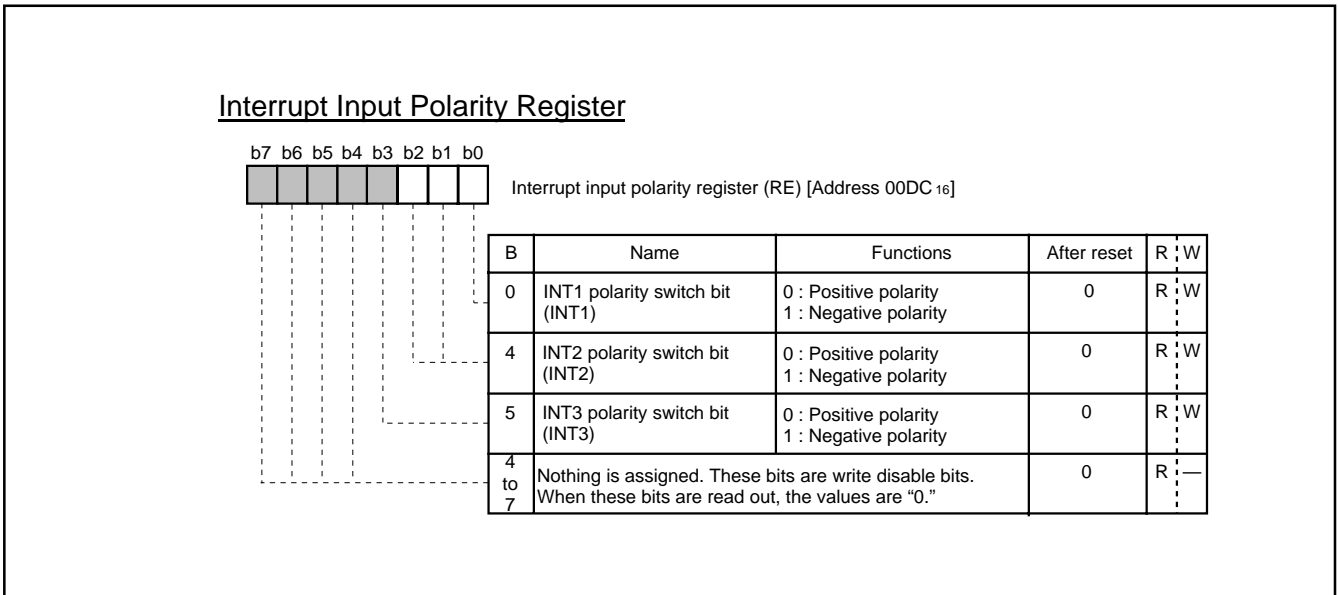

Fig. 8.3.6 Interrupt Input Polarity Register

M37272M6H/M8H/MAH/MFH-XXXSP/FP M37272E8SP/FP, M37272EFSP/FP

SINGLE-CHIP 8-BIT CMOS MICROCOMPUTER with CLOSED CAPTION DECODER
and ON-SCREEN DISPLAY CONTROLLER

8.4 TIMERS

This microcomputer has 6 timers: timer 1, timer 2, timer 3, timer 4, timer 5, and timer 6. All timers are 8-bit timers with the 8-bit timer latch. The timer block diagram is shown in Figure 8.4.3.

All of the timers count down and their divide ratio is $1/(n+1)$, where n is the value of timer latch. By writing a count value to the corresponding timer latch (addresses 00F0₁₆ to 00F3₁₆: timers 1 to 4, addresses 00EE₁₆ and 00EF₁₆: timers 5 and 6), the value is also set to a timer, simultaneously.

The count value is decremented by 1. The timer interrupt request bit is set to "1" by a timer overflow at the next count pulse, after the count value reaches "00₁₆".

8.4.1 Timer 1

Timer 1 can select one of the following count sources:

- $f(X_{IN})/16$ or $f(X_{CIN})/16$
- $f(X_{IN})/4096$ or $f(X_{CIN})/4096$
- External clock from the TIM2 pin

The count source of timer 1 is selected by setting bits 5 and 0 of timer mode register 1 (address 00F4₁₆). Either $f(X_{IN})$ or $f(X_{CIN})$ is selected by bit 7 of the CPU mode register.

Timer 1 interrupt request occurs at timer 1 overflow.

8.4.2 Timer 2

Timer 2 can select one of the following count sources:

- $f(X_{IN})/16$ or $f(X_{CIN})/16$
- Timer 1 overflow signal
- External clock from the TIM2 pin

The count source of timer 2 is selected by setting bits 4 and 1 of timer mode register 1 (address 00F4₁₆). Either $f(X_{IN})$ or $f(X_{CIN})$ is selected by bit 7 of the CPU mode register. When timer 1 overflow signal is a count source for the timer 2, the timer 1 functions as an 8-bit prescaler.

Timer 2 interrupt request occurs at timer 2 overflow.

8.4.3 Timer 3

Timer 3 can select one of the following count sources:

- $f(X_{IN})/16$ or $f(X_{CIN})/16$
- $f(X_{CIN})$
- External clock from the TIM3 pin

The count source of timer 3 is selected by setting bit 0 of timer mode register 2 (address 00F5₁₆) and bit 6 at address 00C7₁₆. Either $f(X_{IN})$ or $f(X_{CIN})$ is selected by bit 7 of the CPU mode register.

Timer 3 interrupt request occurs at timer 3 overflow.

8.4.4 Timer 4

Timer 4 can select one of the following count sources:

- $f(X_{IN})/16$ or $f(X_{CIN})/16$
- $f(X_{IN})/2$ or $f(X_{CIN})/2$
- $f(X_{CIN})$

The count source of timer 3 is selected by setting bits 1 and 4 of the timer mode register 2 (address 00F5₁₆). Either $f(X_{IN})$ or $f(X_{CIN})$ is selected by bit 7 of the CPU mode register. When timer 3 overflow signal is a count source for the timer 4, the timer 3 functions as an 8-bit prescaler.

Timer 4 interrupt request occurs at timer 4 overflow.

8.4.5 Timer 5

Timer 5 can select one of the following count sources:

- $f(X_{IN})/16$ or $f(X_{CIN})/16$
- Timer 2 overflow signal
- Timer 4 overflow signal

The count source of timer 3 is selected by setting bit 6 of timer mode register 1 (address 00F4₁₆) and bit 7 of the timer mode register 2 (address 00F5₁₆). When overflow of timer 2 or 4 is a count source for timer 5, either timer 2 or 4 functions as an 8-bit prescaler. Either $f(X_{IN})$ or $f(X_{CIN})$ is selected by bit 7 of the CPU mode register.

Timer 5 interrupt request occurs at timer 5 overflow.

8.4.6 Timer 6

Timer 6 can select one of the following count sources:

- $f(X_{IN})/16$ or $f(X_{CIN})/16$
- Timer 5 overflow signal

The count source of timer 6 is selected by setting bit 7 of the timer mode register 1 (address 00F4₁₆). Either $f(X_{IN})$ or $f(X_{CIN})$ is selected by bit 7 of the CPU mode register. When timer 5 overflow signal is a count source for timer 6, the timer 5 functions as an 8-bit prescaler. Timer 6 interrupt request occurs at timer 6 overflow.

At reset, timers 3 and 4 are connected by hardware and "FF₁₆" is automatically set in timer 3; "07₁₆" in timer 4. The $f(X_{IN})^*/16$ is selected as the timer 3 count source. The internal reset is released by timer 4 overflow in this state and the internal clock is connected.

At execution of the STP instruction, timers 3 and 4 are connected by hardware and "FF₁₆" is automatically set in timer 3; "07₁₆" in timer 4. However, the $f(X_{IN})^*/16$ is not selected as the timer 3 count source. So set both bit 0 of timer mode register 2 (address 00F5₁₆) and bit 6 at address 00C7₁₆ to "0" before the execution of the STP instruction ($f(X_{IN})^*/16$ is selected as timer 3 count source). The internal STP state is released by timer 4 overflow in this state and the internal clock is connected.

As a result of the above procedure, the program can start under a stable clock.

*: When bit 7 of the CPU mode register (CM7) is "1," $f(X_{IN})$ becomes $f(X_{CIN})$.

The timer-related registers is shown in Figures 8.4.1 and 8.4.2.

M37272M6H/M8H/MAH/MFH-XXXSP/FP M37272E8SP/FP, M37272EFSP/FP

SINGLE-CHIP 8-BIT CMOS MICROCOMPUTER with CLOSED CAPTION DECODER
and ON-SCREEN DISPLAY CONTROLLER

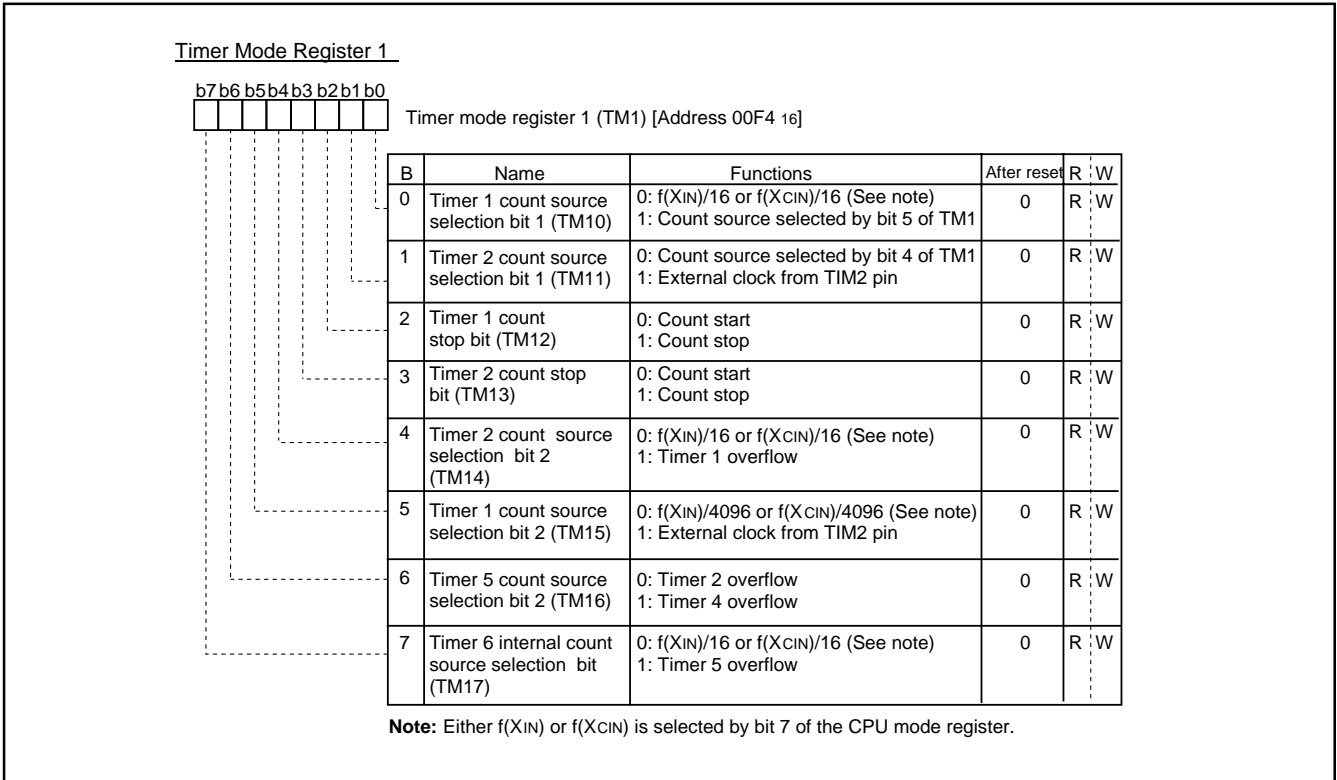

Fig. 8.4.1 Timer Mode Register 1

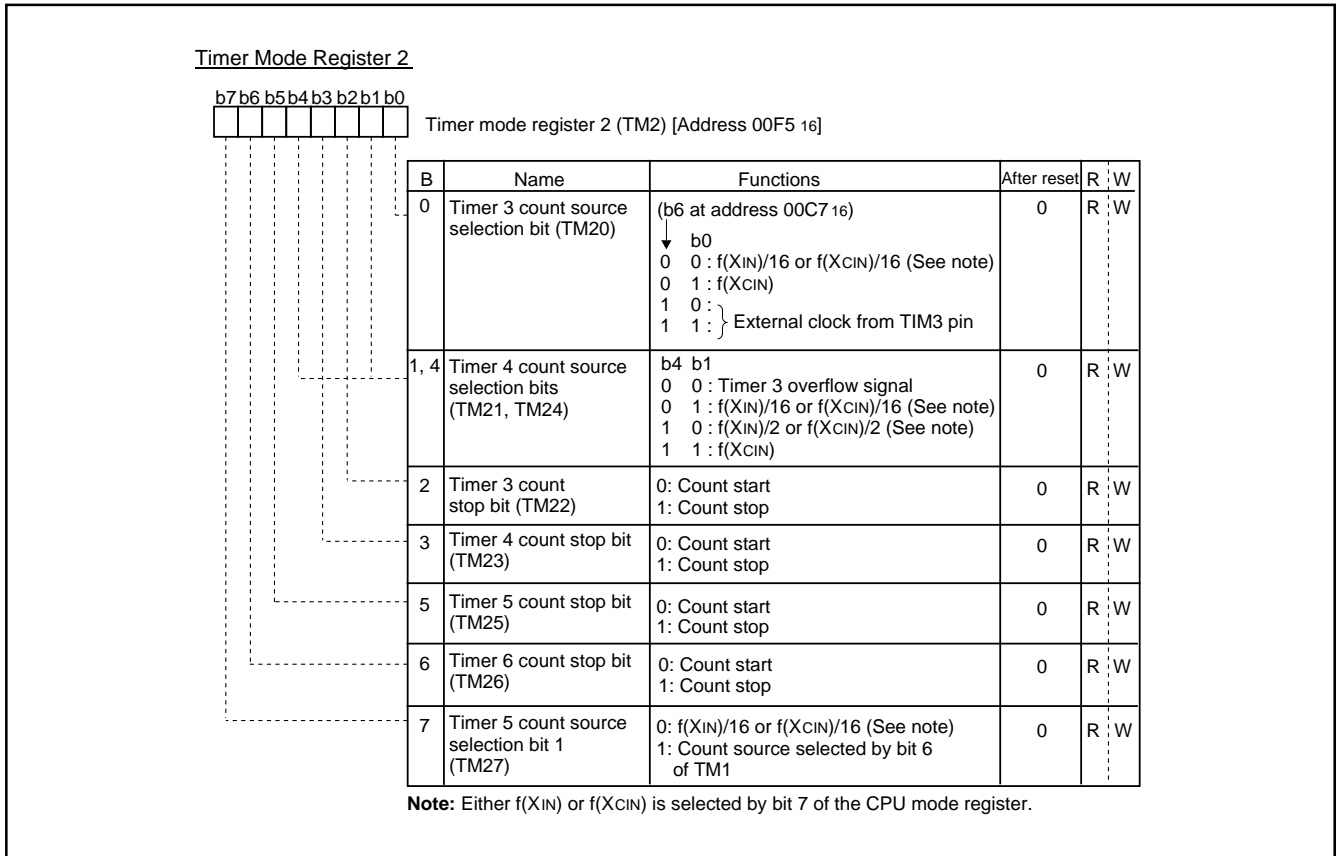

Fig. 8.4.2 Timer Mode Register 2

M37272M6H/M8H/MAH/MFH-XXXSP/FP
M37272E8SP/FP, M37272EFSP/FP

SINGLE-CHIP 8-BIT CMOS MICROCOMPUTER with CLOSED CAPTION DECODER
 and ON-SCREEN DISPLAY CONTROLLER

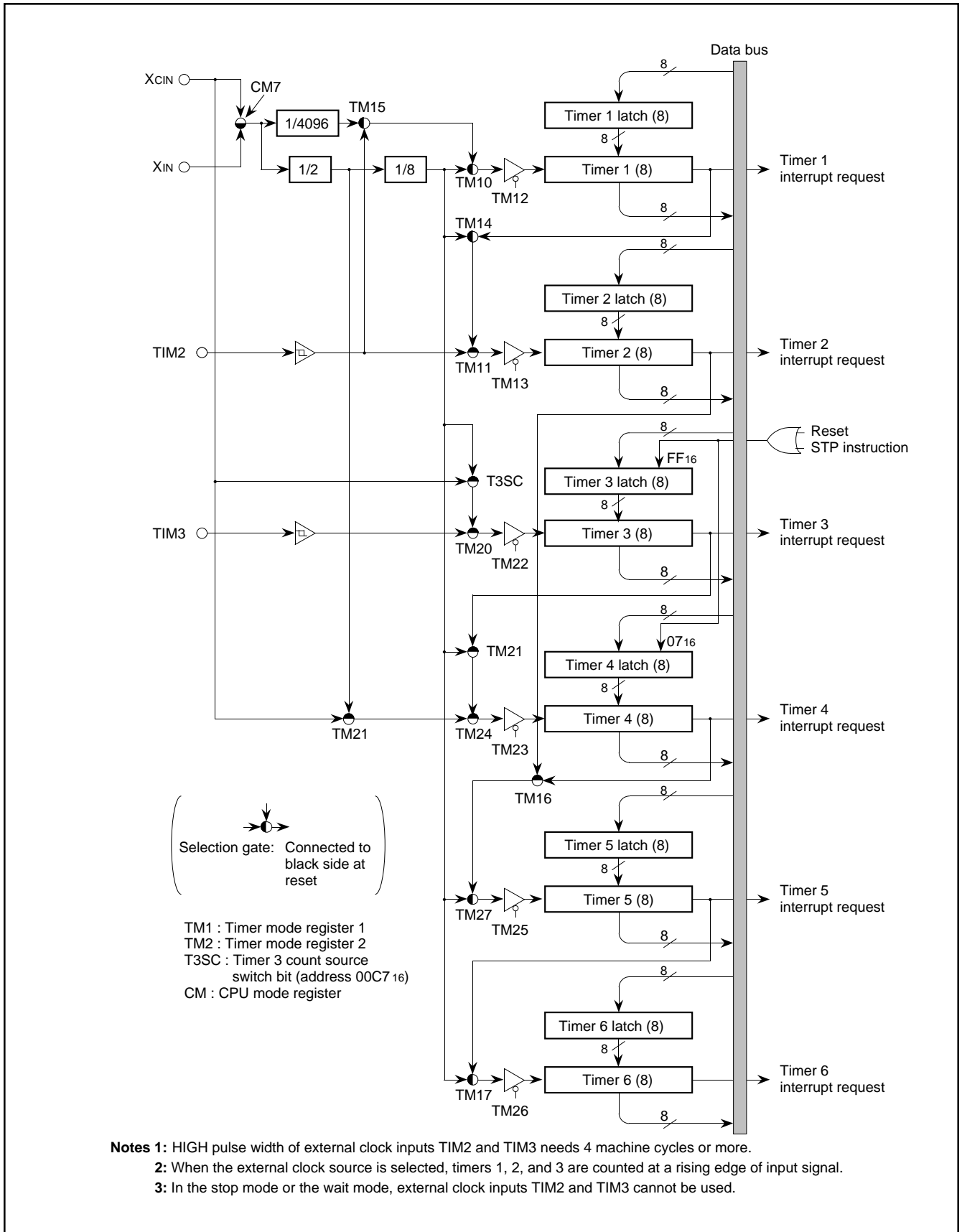

Fig. 8.4.3 Timer Block Diagram

M37272M6H/M8H/MAH/MFH-XXXSP/FP M37272E8SP/FP, M37272EFSP/FP

SINGLE-CHIP 8-BIT CMOS MICROCOMPUTER with CLOSED CAPTION DECODER
and ON-SCREEN DISPLAY CONTROLLER

8.5 SERIAL I/O

This microcomputer has a built-in serial I/O which can either transmit or receive 8-bit data serially in the clock synchronous mode.

The serial I/O block diagram is shown in Figure 8.5.1. The synchronous clock I/O pin (SCLK), and data output pin (SOUT) also function as port P4, data input pin (SIN) also functions as port P20-P22.

Bit 3 of the serial I/O mode register (address 00EB16) selects whether the synchronous clock is supplied internally or externally (from the SCLK pin). When an internal clock is selected, bits 1 and 0 select whether $f(XIN)$ or $f(XCIN)$ is divided by 8, 16, 32, or 64. To use the SIN pin for serial I/O, set the corresponding bit of the port P2 direction register (address 00C516) to "0."

The operation of the serial I/O is described below. The operation of the serial I/O differs depending on the clock source; external clock or internal clock.

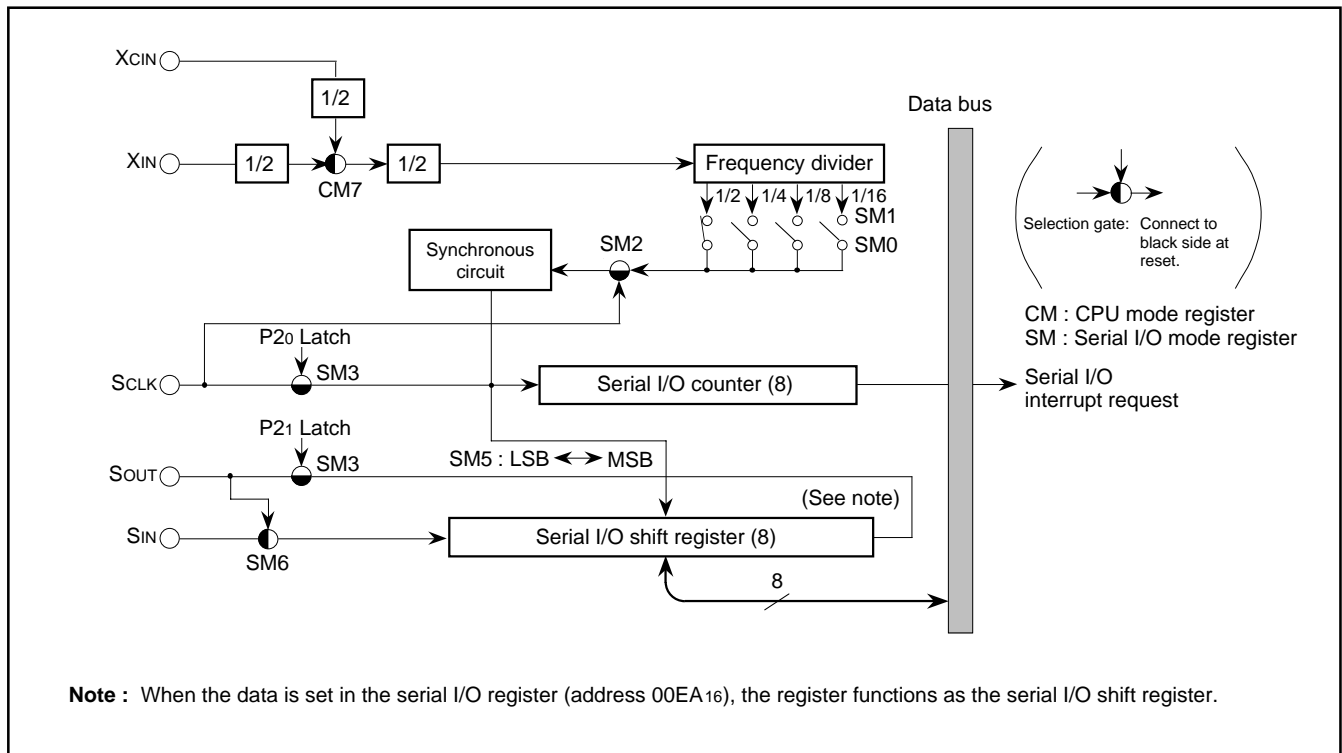

Fig. 8.5.1 Serial I/O Block Diagram

M37272M6H/M8H/MAH/MFH-XXXSP/FP M37272E8SP/FP, M37272EFSP/FP

SINGLE-CHIP 8-BIT CMOS MICROCOMPUTER with CLOSED CAPTION DECODER
and ON-SCREEN DISPLAY CONTROLLER

Internal clock : The serial I/O counter is set to "7" during the write cycle into the serial I/O register (address 00EA16), and the transfer clock goes HIGH forcibly. At each falling edge of the transfer clock after the write cycle, serial data is output from the SOUT pin. Transfer direction can be selected by bit 5 of the serial I/O mode register. At each rising edge of the transfer clock, data is input from the SIN pin and data in the serial I/O register is shifted 1 bit. After the transfer clock has counted 8 times, the serial I/O counter becomes "0" and the transfer clock stops at HIGH. At this time the interrupt request bit is set to "1."

External clock : The an external clock is selected as the clock source, the interrupt request is set to "1" after the transfer clock has been counted 8 counts. However, transfer operation does not stop, so the clock should be controlled externally. Use the external clock of 1 MHz or less with a duty cycle of 50%. The serial I/O timing is shown in Figure 8.5.2. When using an external clock for transfer, the external clock must be held at HIGH for initializing the serial I/O counter. When switching between an internal clock and an external clock, do not switch during transfer. Also, be sure to initialize the serial I/O counter after switching.

- Notes 1:** On programming, note that the serial I/O counter is set by writing to the serial I/O register with the bit managing instructions, such as SEB and CLB.
- 2:** When an external clock is used as the synchronous clock, write transmit data to the serial I/O register when the transfer clock input level is HIGH.

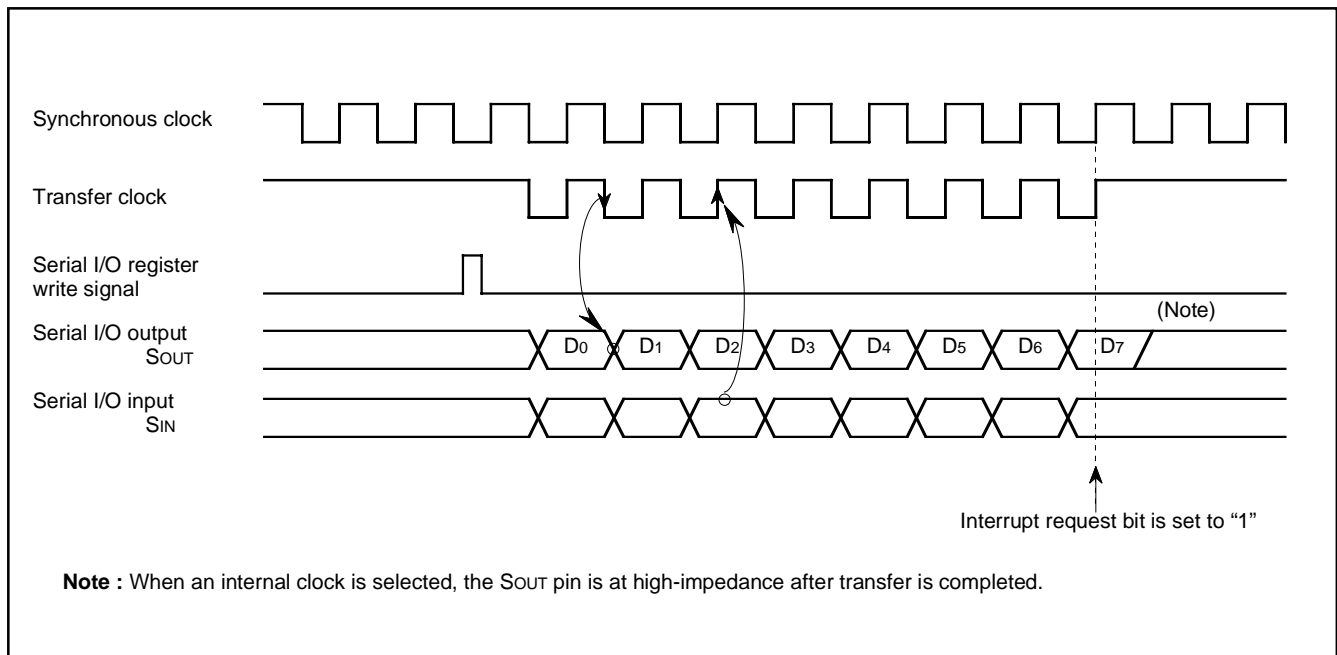

Fig. 8.5.2 Serial I/O Timing (for LSB first)

M37272M6H/M8H/MAH/MFH-XXXSP/FP
M37272E8SP/FP, M37272EFSP/FP

SINGLE-CHIP 8-BIT CMOS MICROCOMPUTER with CLOSED CAPTION DECODER
 and ON-SCREEN DISPLAY CONTROLLER

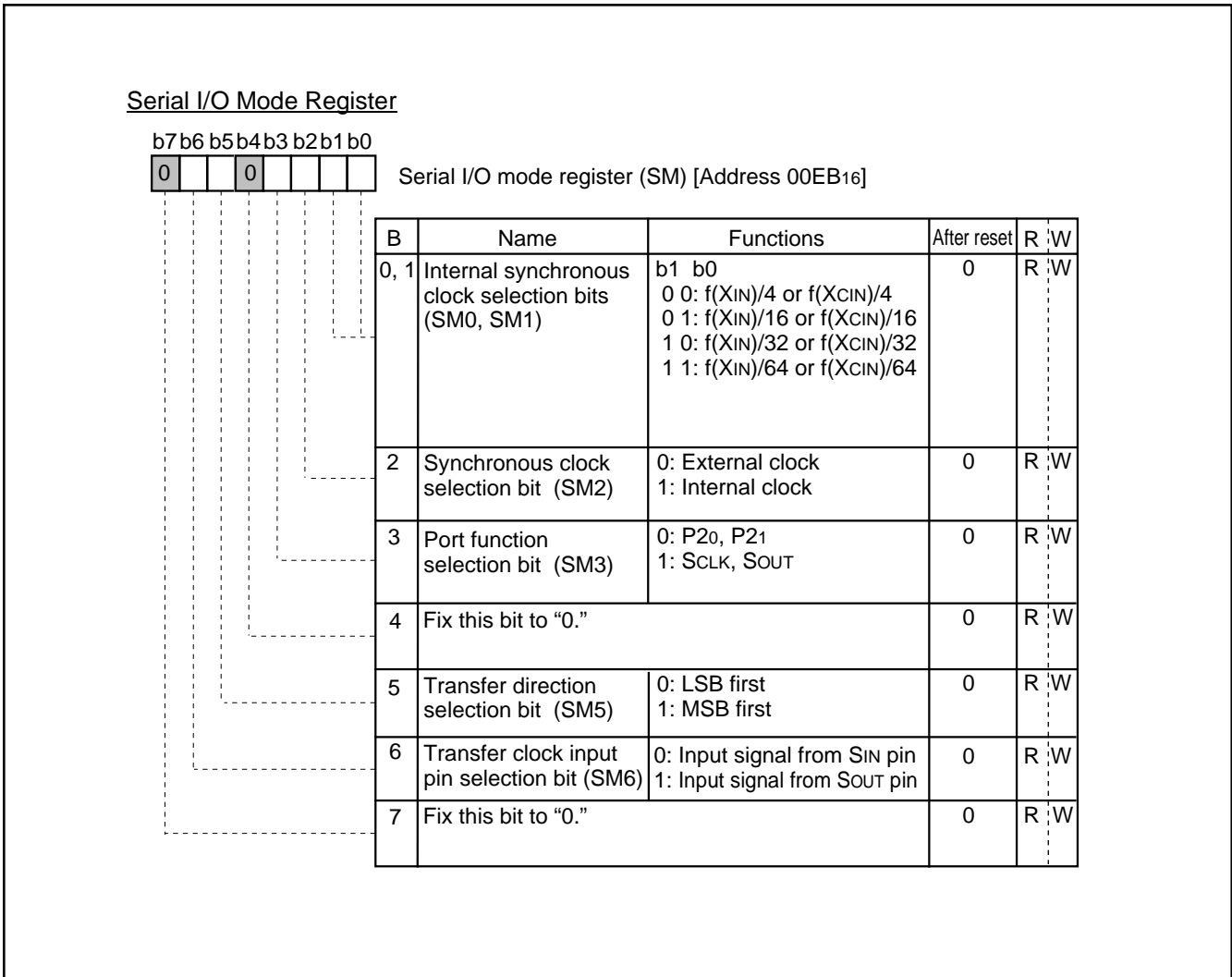

Fig. 8.5.3 Serial I/O Mode Register

M37272M6H/M8H/MAH/MFH-XXXSP/FP M37272E8SP/FP, M37272EFSP/FP

SINGLE-CHIP 8-BIT CMOS MICROCOMPUTER with CLOSED CAPTION DECODER
and ON-SCREEN DISPLAY CONTROLLER

8.6 MULTI-MASTER I²C-BUS INTERFACE

The multi-master I²C-BUS interface is a serial communications circuit, conforming to the Philips I²C-BUS data transfer format. This interface, offering both arbitration lost detection and a synchronous functions, is useful for the multi-master serial communications. Figure 8.6.1 shows a block diagram of the multi-master I²C-BUS interface and Table 8.6.1 shows multi-master I²C-BUS interface functions.

This multi-master I²C-BUS interface consists of the I²C address register, the I²C data shift register, the I²C clock control register, the I²C control register, the I²C status register and other control circuits.

Table 8.6.1 Multi-master I²C-BUS Interface Functions

Item	Function
Format	In conformity with Philips I ² C-BUS standard: 10-bit addressing format 7-bit addressing format High-speed clock mode Standard clock mode
Communication mode	In conformity with Philips I ² C-BUS standard: Master transmission Master reception Slave transmission Slave reception
SCL clock frequency	16.1 kHz to 400 kHz (at $\phi = 4$ MHz)

ϕ : System clock = $f(XIN)/2$

Note : We are not responsible for any third party's infringement of patent rights or other rights attributable to the use of the control function (bits 6 and 7 of the I²C control register at address 00F916) for connections between the I²C-BUS interface and ports (SCL1, SCL2, SDA1, SDA2).

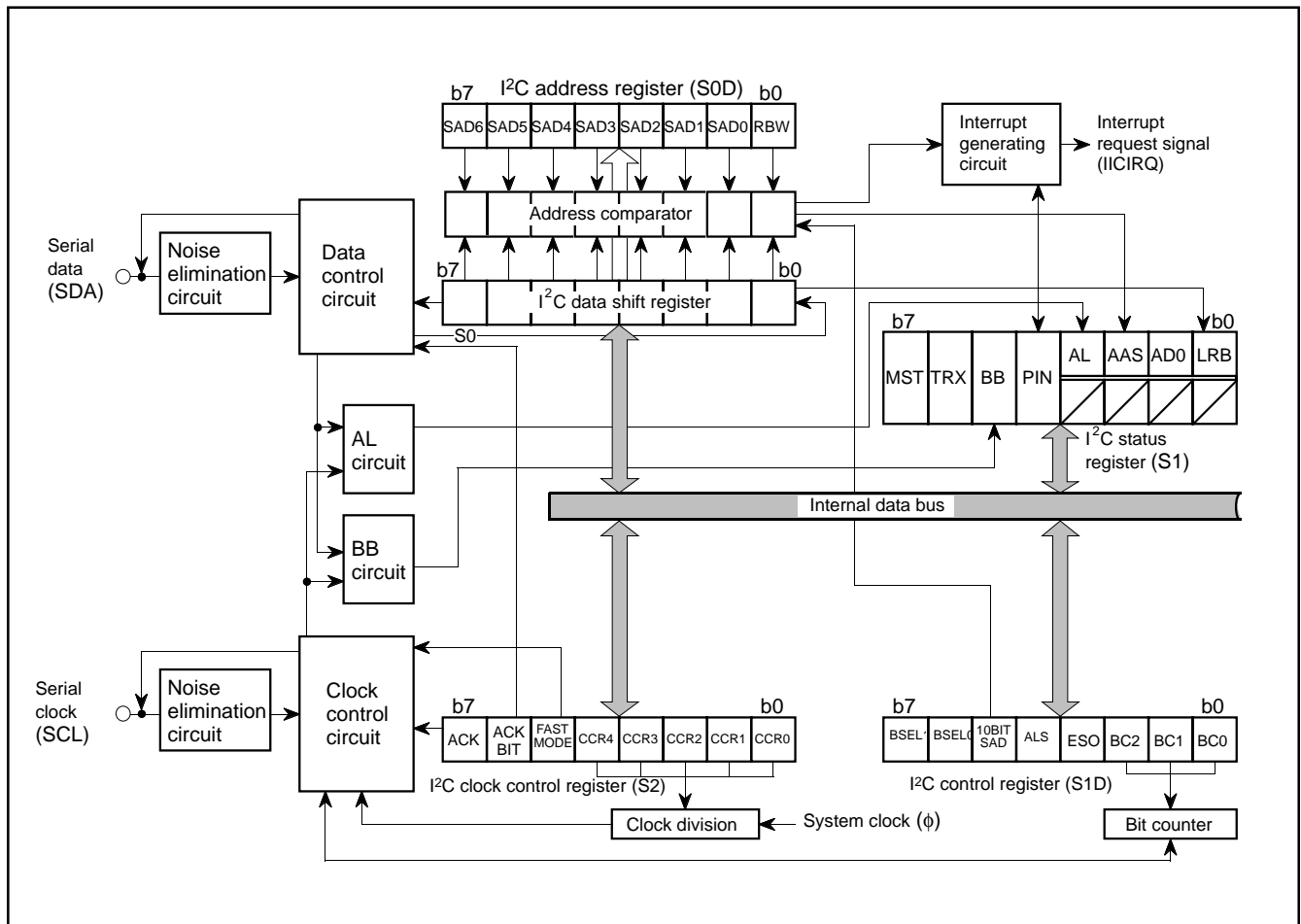

Fig. 8.6.1 Block Diagram of Multi-master I²C-BUS Interface

M37272M6H/M8H/MAH/MFH-XXXSP/FP M37272E8SP/FP, M37272EFSP/FP

SINGLE-CHIP 8-BIT CMOS MICROCOMPUTER with CLOSED CAPTION DECODER
and ON-SCREEN DISPLAY CONTROLLER

8.6.1 I²C Data Shift Register

The I²C data shift register (S0 : address 00F6₁₆) is an 8-bit shift register to store receive data and write transmit data.

When transmit data is written into this register, it is transferred to the outside from bit 7 in synchronization with the SCL clock, and each time one-bit data is output, the data of this register are shifted one bit to the left. When data is received, it is input to this register from bit 0 in synchronization with the SCL clock, and each time one-bit data is input, the data of this register are shifted one bit to the left.

The I²C data shift register is in a write enable status only when the ESO bit of the I²C control register (address 00F9₁₆) is "1." The bit counter is reset by a write instruction to the I²C data shift register. When both the ESO bit and the MST bit of the I²C status register (address 00F8₁₆) are "1," the SCL is output by a write instruction to the I²C data shift register. Reading data from the I²C data shift register is always enabled regardless of the ESO bit value.

Note: To write data into the I²C data shift register after setting the MST bit to "0" (slave mode), keep an interval of 8 machine cycles or more.

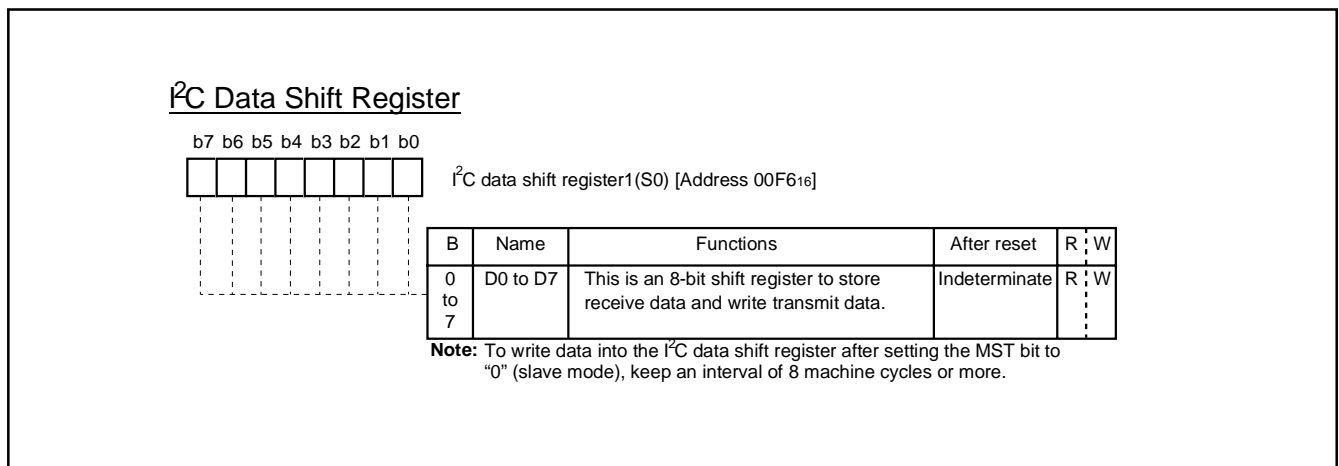

Fig. 8.6.2 Data Shift Register

M37272M6H/M8H/MAH/MFH-XXXSP/FP M37272E8SP/FP, M37272EFSP/FP

SINGLE-CHIP 8-BIT CMOS MICROCOMPUTER with CLOSED CAPTION DECODER
and ON-SCREEN DISPLAY CONTROLLER

8.6.2 I²C Address Register

The I²C address register (address 00F7₁₆) consists of a 7-bit slave address and a read/write bit. In the addressing mode, the slave address written in this register is compared with the address data to be received immediately after the START condition are detected.

(1) Bit 0: read/write bit (RBW)

Not used when comparing addresses, in the 7-bit addressing mode. In the 10-bit addressing mode, the first address data to be received is compared with the contents (SAD₆ to SAD₀ + RBW) of the I²C address register.

The RBW bit is cleared to "0" automatically when the stop condition is detected.

(2) Bits 1 to 7: slave address (SAD₀–SAD₆)

These bits store slave addresses. Regardless of the 7-bit addressing mode and the 10-bit addressing mode, the address data transmitted from the master is compared with the contents of these bits.

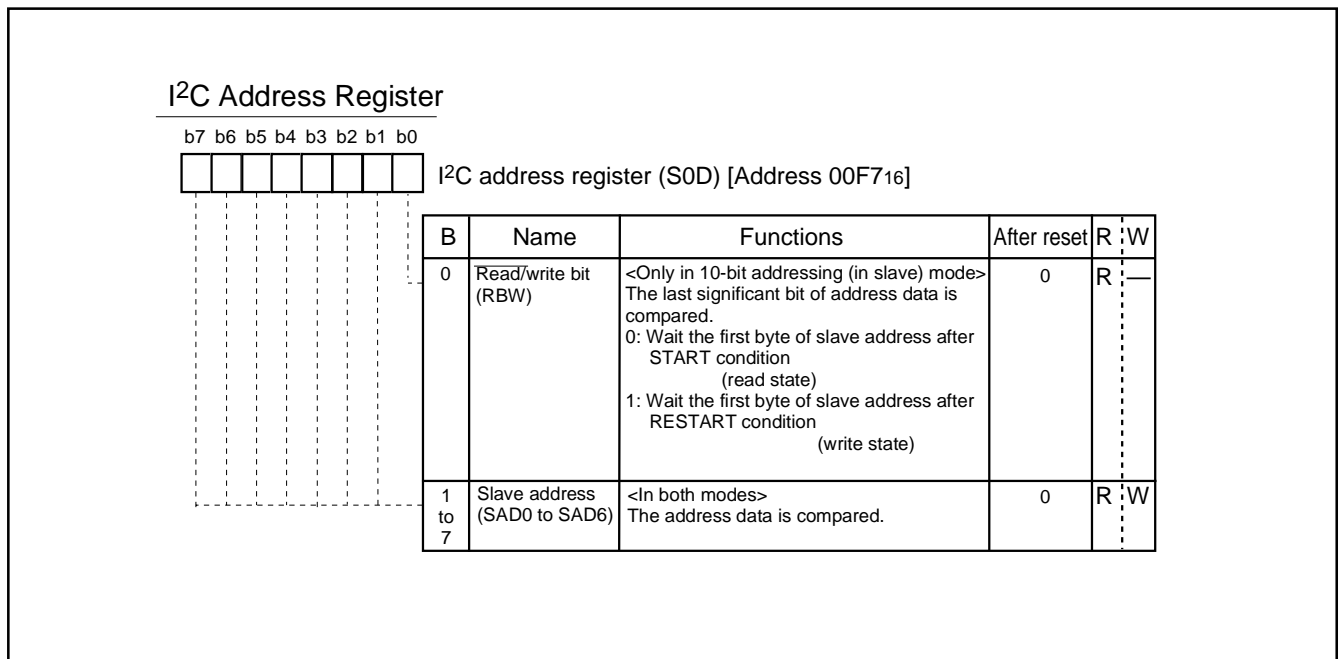

Fig. 8.6.3 I²C Address Register

M37272M6H/M8H/MAH/MFH-XXXSP/FP M37272E8SP/FP, M37272EFSP/FP

SINGLE-CHIP 8-BIT CMOS MICROCOMPUTER with CLOSED CAPTION DECODER
and ON-SCREEN DISPLAY CONTROLLER

8.6.3 I²C Clock Control Register

The I²C clock control register (address 00FA₁₆) is used to set ACK control, SCL mode and SCL frequency.

(1) Bits 0 to 4: SCL frequency control bits (CCR0-CCR4)

These bits control the SCL frequency.

(2) Bit 5: SCL mode specification bit (FAST MODE)

This bit specifies the SCL mode. When this bit is set to "0," the standard clock mode is set. When the bit is set to "1," the high-speed clock mode is set.

(3) Bit 6: ACK bit (ACK BIT)

This bit sets the SDA status when an ACK clock* is generated. When this bit is set to "0," the ACK return mode is set and SDA goes to LOW at the occurrence of an ACK clock. When the bit is set to "1," the ACK non-return mode is set. The SDA is held in the HIGH status at the occurrence of an ACK clock.

However, when the slave address matches the address data in the reception of address data at ACK BIT = "0," the SDA is automatically made LOW (ACK is returned). If there is a mismatch between the slave address and the address data, the SDA is automatically made HIGH (ACK is not returned).

(4) Bit 7: ACK clock bit (ACK)

This bit specifies a mode of acknowledgment which is an acknowledgment response of data transmission. When this bit is set to "0," the no ACK clock mode is set. In this case, no ACK clock occurs after data transmission. When the bit is set to "1," the ACK clock mode is set and the master generates an ACK clock upon completion of each 1-byte data transmission. The device for transmitting address data and control data releases the SDA at the occurrence of an ACK clock (make SDA HIGH) and receives the ACK bit generated by the data receiving device.

Note: Do not write data into the I²C clock control register during transmission. If data is written during transmission, the I²C clock generator is reset, so that data cannot be transmitted normally.

*ACK clock: Clock for acknowledgement

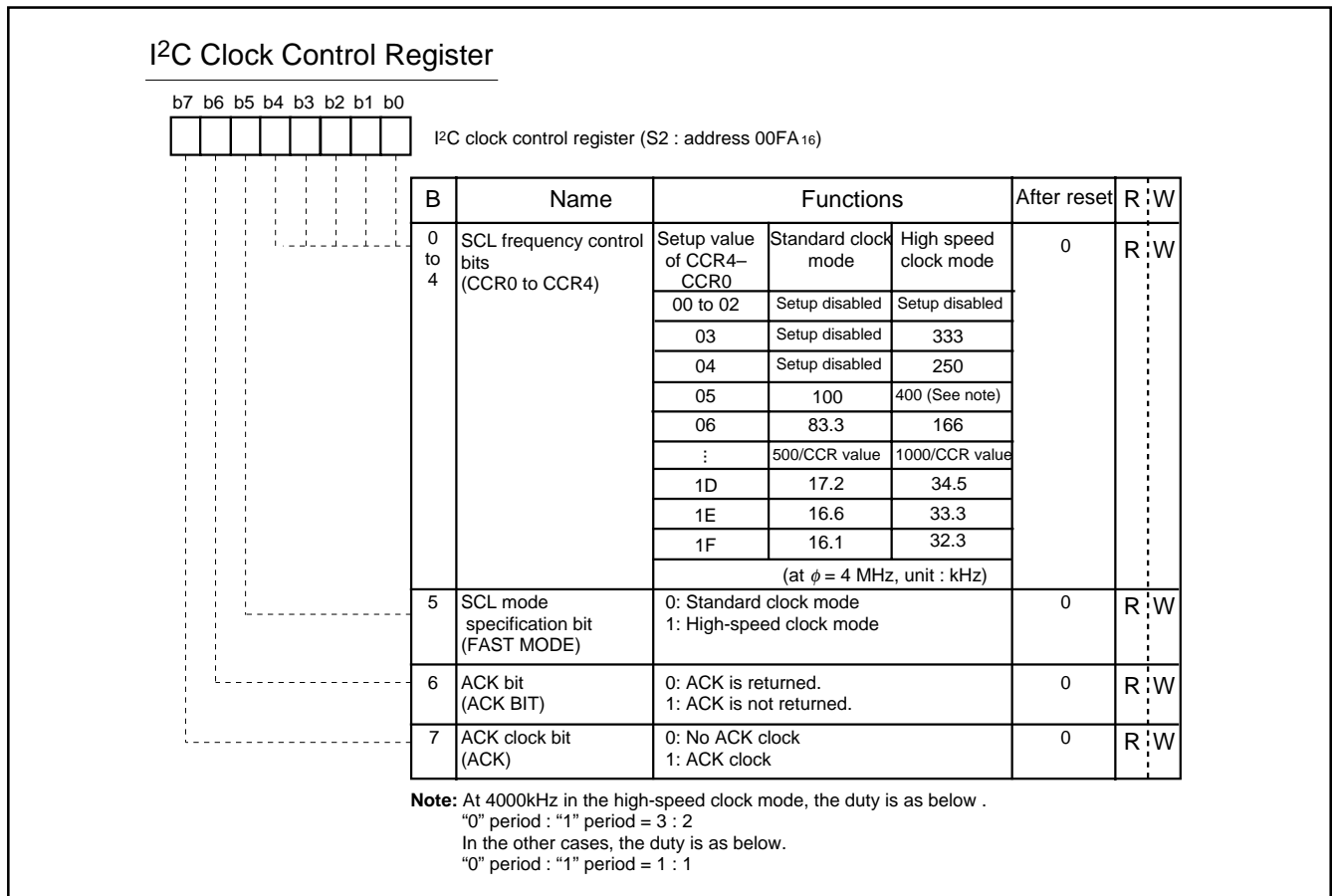

Fig. 8.6.4 I²C Address Register

M37272M6H/M8H/MAH/MFH-XXXSP/FP M37272E8SP/FP, M37272EFSP/FP

SINGLE-CHIP 8-BIT CMOS MICROCOMPUTER with CLOSED CAPTION DECODER
and ON-SCREEN DISPLAY CONTROLLER

8.6.4 I²C Control Register

The I²C control register (address 00F9₁₆) controls the data communication format.

(1) Bits 0 to 2: bit counter (BC0-BC2)

These bits decide the number of bits for the next 1-byte data to be transmitted. An interrupt request signal occurs immediately after the number of bits specified with these bits are transmitted.

When a START condition is received, these bits become "000₂" and the address data is always transmitted and received in 8 bits.

(2) Bit 3: I²C interface use enable bit (ESO)

This bit enables usage of the multimaster I²C BUS interface. When this bit is set to "0," the use disable status is provided, so the SDA and the SCL become high-impedance. When the bit is set to "1," use of the interface is enabled.

When ESO = "0," the following is performed.

- PIN = "1," BB = "0" and AL = "0" are set (they are bits of the I²C status register at address 00F8₁₆).
- Writing data to the I²C data shift register (address 00F6₁₆) is disabled.

(3) Bit 4: data format selection bit (ALS)

This bit decides whether or not to recognize slave addresses. When this bit is set to "0," the addressing format is selected, so that address data is recognized. When a match is found between a slave address and address data as a result of comparison or when a general call (refer to "8.6.5 I²C Status Register," bit 1) is received, transmission processing can be performed. When this bit is set to "1," the free data format is selected, so that slave addresses are not recognized.

(4) Bit 5: addressing format selection bit (10BIT SAD)

This bit selects a slave address specification format. When this bit is set to "0," the 7-bit addressing format is selected. In this case, only the high-order 7 bits (slave address) of the I²C address register (address 00F7₁₆) are compared with address data. When this bit is set to "1," the 10-bit addressing format is selected, all the bits of the I²C address register are compared with address data.

(5) Bits 6 and 7: connection control bits between I²C-BUS interface and ports (BSEL0, BSEL1)

These bits controls the connection between SCL and ports or SDA and ports (refer to Figure 8.6.5).

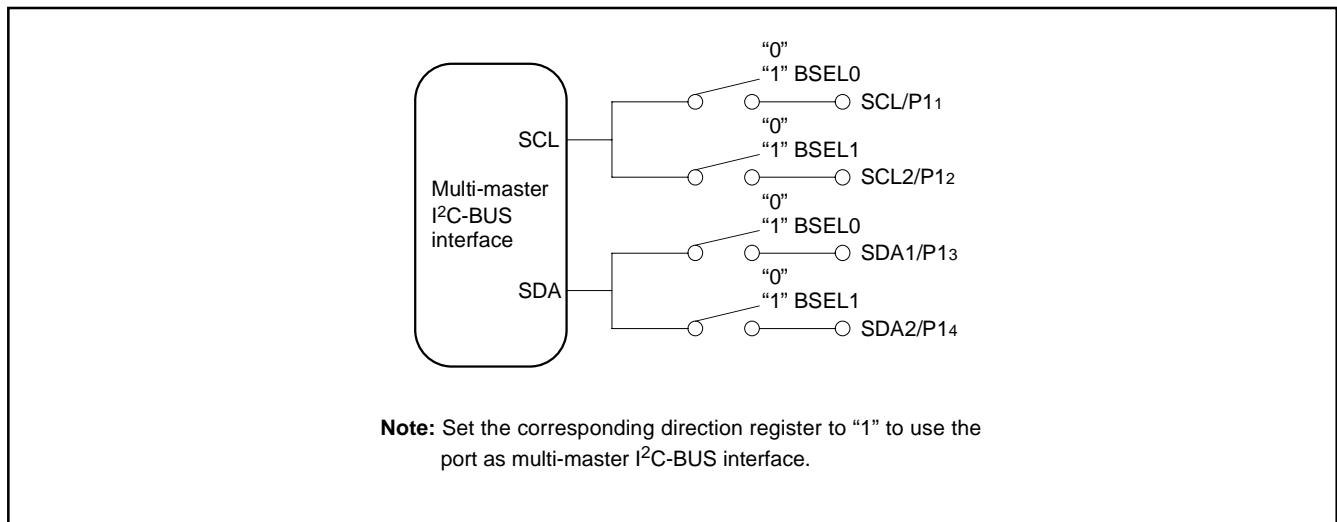

Fig. 8.6.5 Connection Port Control by BSEL0 and BSEL1

M37272M6H/M8H/MAH/MFH-XXXSP/FP
M37272E8SP/FP, M37272EFSP/FP

SINGLE-CHIP 8-BIT CMOS MICROCOMPUTER with CLOSED CAPTION DECODER
 and ON-SCREEN DISPLAY CONTROLLER

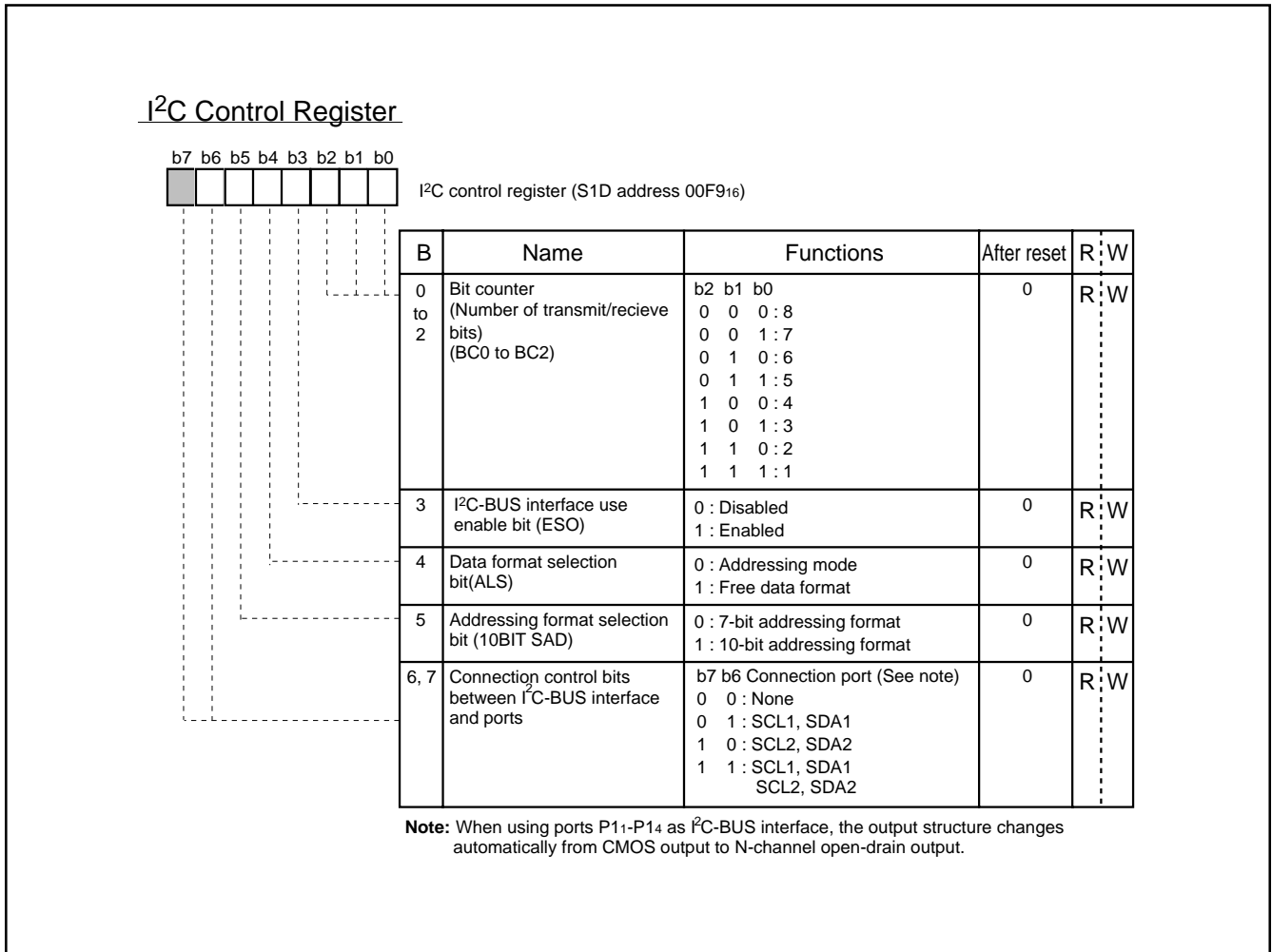

Fig. 8.6.6 I²C Control Register

M37272M6H/M8H/MAH/MFH-XXXSP/FP M37272E8SP/FP, M37272EFSP/FP

SINGLE-CHIP 8-BIT CMOS MICROCOMPUTER with CLOSED CAPTION DECODER
and ON-SCREEN DISPLAY CONTROLLER

8.6.5 I²C Status Register

The I²C status register (address 00F8₁₆) controls the I²C-BUS interface status. The low-order 4 bits are read-only bits and the high-order 4 bits can be read out and written to.

(1) Bit 0: last receive bit (LRB)

This bit stores the last bit value of received data and can also be used for ACK receive confirmation. If ACK is returned when an ACK clock occurs, the LRB bit is set to "0." If ACK is not returned, this bit is set to "1." Except in the ACK mode, the last bit value of received data is input. The state of this bit is changed from "1" to "0" by executing a write instruction to the I²C data shift register (address 00F6₁₆).

(2) Bit 1: general call detecting flag (AD0)

This bit is set to "1" when a general call* whose address data is all "0" is received in the slave mode. By a general call of the master device, every slave device receives control data after the general call. The AD0 bit is set to "0" by detecting the STOP condition or START condition.

*General call: The master transmits the general call address "00₁₆" to all slaves.

(3) Bit 2: slave address comparison flag (AAS)

This flag indicates a comparison result of address data.

- In the slave receive mode, when the 7-bit addressing format is selected, this bit is set to "1" in one of the following conditions.
 - The address data immediately after occurrence of a START condition matches the slave address stored in the high-order 7 bits of the I²C address register (address 00F7₁₆).
 - A general call is received.
- In the slave reception mode, when the 10-bit addressing format is selected, this bit is set to "1" with the following condition.
 - When the address data is compared with the I²C address register (8 bits consists of slave address and RBW), the first bytes match.
- The state of this bit is changed from "1" to "0" by executing a write instruction to the I²C data shift register (address 00F6₁₆).

(4) Bit 3: arbitration lost* detecting flag (AL)

In the master transmission mode, when a device other than the microcomputer sets the SDA to "L," arbitration is judged to have been lost, so that this bit is set to "1." At the same time, the TRX bit is set to "0," so that immediately after transmission of the byte whose arbitration was lost is completed, the MST bit is set to "0." When arbitration is lost during slave address transmission, the TRX bit is set to "0" and the reception mode is set. Consequently, it becomes possible to receive and recognize its own slave address transmitted by another master device.

*Arbitration lost: The status in which communication as a master is disabled.

(5) Bit 4: I²C-BUS interface interrupt request bit (PIN)

This bit generates an interrupt request signal. Each time 1-byte data is transmitted, the state of the PIN bit changes from "1" to "0." At the same time, an interrupt request signal is sent to the CPU. The PIN bit is set to "0" in synchronization with a falling edge of the last clock (including the ACK clock) of an internal clock and an interrupt request signal occurs in synchronization with a falling edge of the PIN bit. When detecting the STOP condition in slave, the multi-master I²C-BUS interface interrupt request bit (IR) is set to "1" (interrupt request) regardless of falling of PIN bit. When the PIN bit is "0," the SCL is kept in the "0" state and clock generation is disabled. Figure 8.6.8 shows an interrupt request signal generating timing chart. The PIN bit is set to "1" in any one of the following conditions.

- Writing "1" to the PIN bit
- Executing a write instruction to the I²C data shift register (address 00F6₁₆). (See note)
- When the ESO bit is "0"
- At reset

Note: It takes 8 BCLK cycles or more until PIN bit becomes "1" after write instructions are executed to these registers.

The conditions in which the PIN bit is set to "0" are shown below:

- Immediately after completion of 1-byte data transmission (including when arbitration lost is detected)
- Immediately after completion of 1-byte data reception
- In the slave reception mode, with ALS = "0" and immediately after completion of slave address or general call address reception
- In the slave reception mode, with ALS = "1" and immediately after completion of address data reception

(6) Bit 5: bus busy flag (BB)

This bit indicates the status of use of the bus system. When this bit is set to "0," this bus system is not busy and a START condition can be generated. When this bit is set to "1," this bus system is busy and the occurrence of a START condition is disabled by the START condition duplication prevention function (See note).

This flag can be written by software only in the master transmission mode. In the other modes, this bit is set to "1" by detecting a START condition and set to "0" by detecting a STOP condition. When the ESO bit of the I²C control register (address 00F9₁₆) is "0" and at reset, the BB flag is kept in the "0" state.

(7) Bit 6: communication mode specification bit (transfer direction specification bit: TRX)

This bit decides the direction of transfer for data communication. When this bit is "0," the reception mode is selected and the data of a transmitting device is received. When the bit is "1," the transmission mode is selected and address data and control data are output into the SDA in synchronization with the clock generated on the SCL.

When the ALS bit of the I²C control register (address 00F9₁₆) is "0" in the slave reception mode is selected, the TRX bit is set to "1" (transmit) if the least significant bit (R/ \bar{W} bit) of the address data transmitted by the master is "1." When the ALS bit is "0" and the R/ \bar{W} bit is "0," the TRX bit is cleared to "0" (receive).

The TRX bit is cleared to "0" in one of the following conditions.

- When arbitration lost is detected.
- When a STOP condition is detected.
- When occurrence of a START condition is disabled by the START condition duplication prevention function (Note).
- With MST = "0" and when a START condition is detected.
- With MST = "0" and when ACK non-return is detected.
- At reset

M37272M6H/M8H/MAH/MFH-XXXSP/FP M37272E8SP/FP, M37272EFSP/FP

SINGLE-CHIP 8-BIT CMOS MICROCOMPUTER with CLOSED CAPTION DECODER
and ON-SCREEN DISPLAY CONTROLLER

(8) Bit 7: Communication mode specification bit (master/slave specification bit: MST)

This bit is used for master/slave specification for data communication. When this bit is "0," the slave is specified, so that a START condition and a STOP condition generated by the master are received, and data communication is performed in synchronization with the clock generated by the master. When this bit is "1," the master is specified and a START condition and a STOP condition are generated, and also the clocks required for data communication are generated on the SCL.

The MST bit is cleared to "0" in one of the following conditions.

- Immediately after completion of 1-byte data transmission when arbitration lost is detected
- When a STOP condition is detected.
- When occurrence of a START condition is disabled by the START condition duplication preventing function (Note).
- At reset

Note: The START condition duplication prevention function disables the START condition generation, reset of bit counter reset, and SCL output, when the following condition is satisfied:
a START condition is set by another master device.

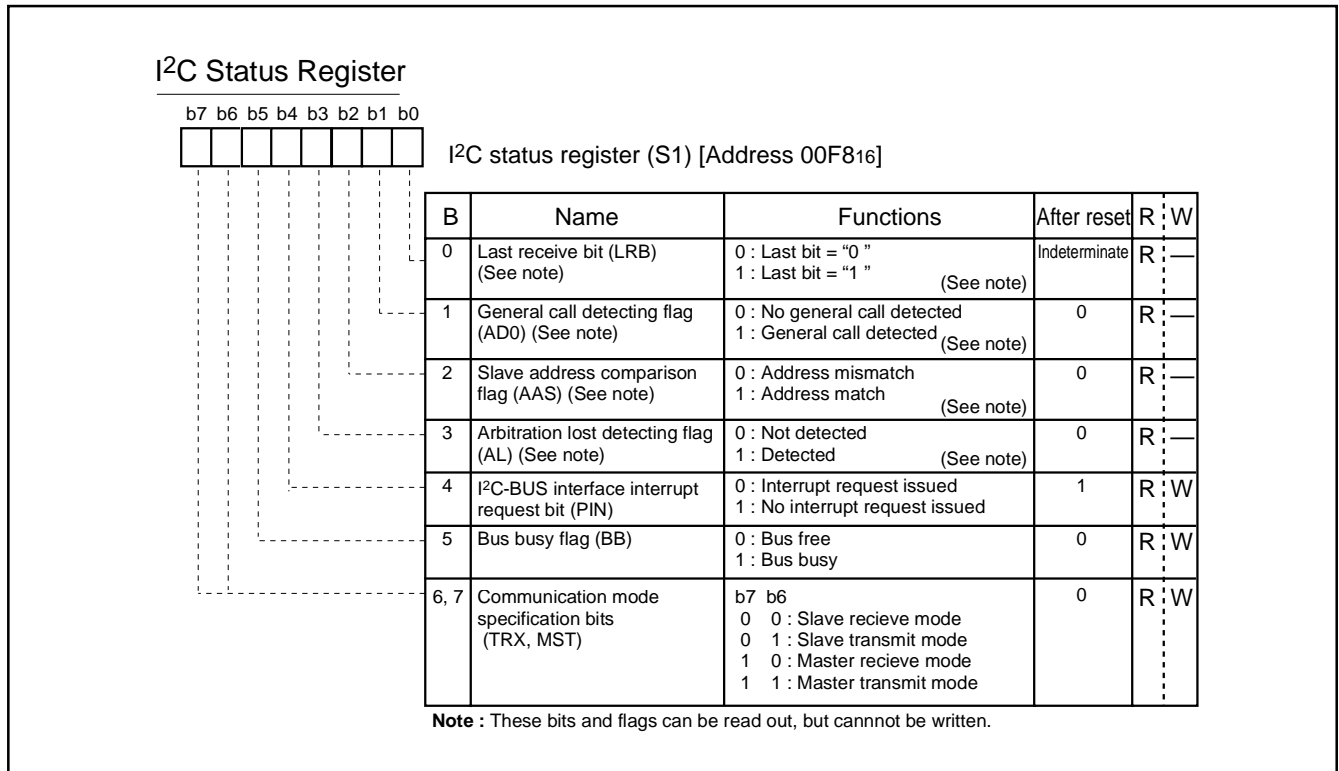

Fig. 8.6.7 I²C Status Register

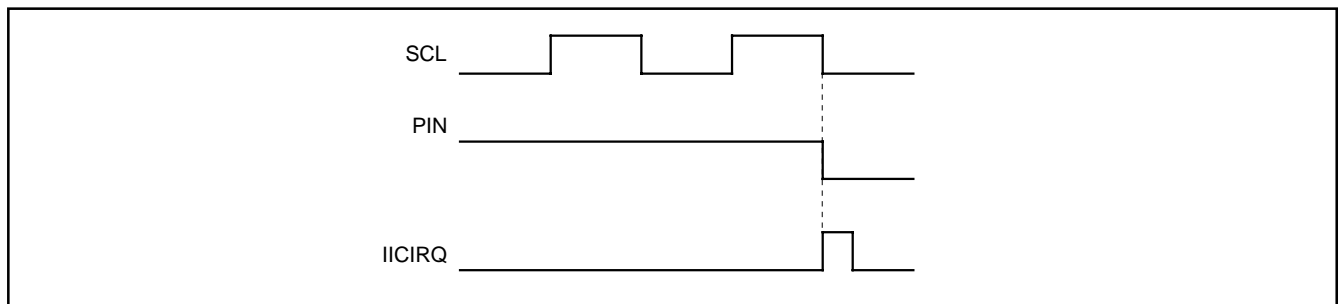

Fig. 8.6.8 Interrupt Request Signal Generation Timing

M37272M6H/M8H/MAH/MFH-XXXSP/FP M37272E8SP/FP, M37272EFSP/FP

SINGLE-CHIP 8-BIT CMOS MICROCOMPUTER with CLOSED CAPTION DECODER
and ON-SCREEN DISPLAY CONTROLLER

8.6.6 START Condition Generation Method

When the ESO bit of the I²C control register (address 00F9₁₆) is "1," execute a write instruction to the I²C status register (address 00F8₁₆) to set the MST, TRX and BB bits to "1." A START condition will then be generated. After that, the bit counter becomes "000₂" and an SCL for 1 byte is output. The START condition generation timing and BB bit set timing are different in the standard clock mode and the high-speed clock mode. Refer to Figure 8.6.9 for the START condition generation timing diagram, and Table 8.6.2 for the START condition/STOP condition generation timing table.

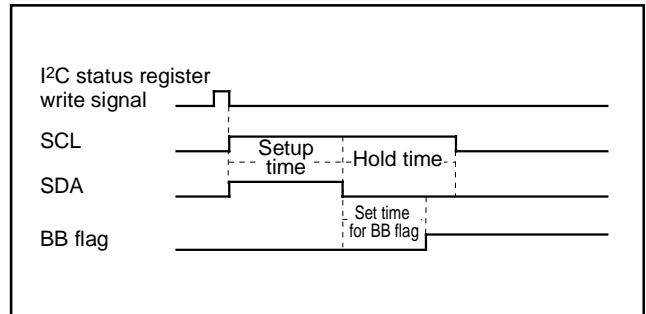

Fig. 8.6.9 START Condition Generation Timing Diagram

8.6.7 STOP Condition Generation Method

When the ESO bit of the I²C control register (address 00F9₁₆) is "1," execute a write instruction to the I²C status register (address 00F8₁₆) for setting the MST bit and the TRX bit to "1" and the BB bit to "0". A STOP condition will then be generated. The STOP condition generation timing and the BB flag reset timing are different in the standard clock mode and the high-speed clock mode. Refer to Figure 8.6.10 for the STOP condition generation timing diagram, and Table 8.6.2 for the START condition/STOP condition generation timing table.

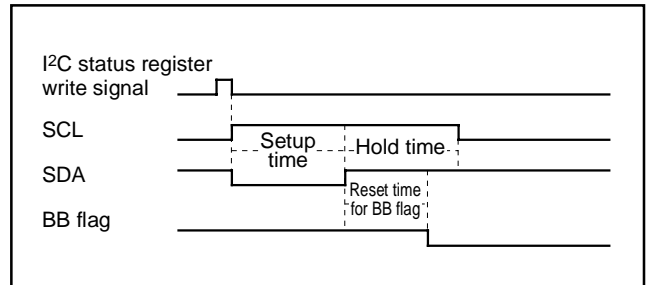

Fig. 8.6.10 STOP Condition Generation Timing Diagram

Table 8.6.2 START Condition/STOP Condition Generation Timing Table

Item	Standard Clock Mode	High-speed Clock Mode
Setup time (START condition)	5.0 μs (20 cycles)	2.5 μs (10 cycles)
Setup time (STOP condition)	4.25 μs (17 cycles)	1.75 μs (7 cycles)
Hold time	5.0 μs (20 cycles)	2.5 μs (10 cycles)
Set/reset time for BB flag	3.0 μs (12 cycles)	1.5 μs (6 cycles)

Note: Absolute time at φ = 4 MHz. The value in parentheses denotes the number of φ cycles.

M37272M6H/M8H/MAH/MFH-XXXSP/FP M37272E8SP/FP, M37272EFSP/FP

SINGLE-CHIP 8-BIT CMOS MICROCOMPUTER with CLOSED CAPTION DECODER
and ON-SCREEN DISPLAY CONTROLLER

8.6.8 START/STOP Condition Detect Conditions

The START/STOP condition detect conditions are shown in Figure 8.6.11 and Table 8.6.3. Only when the 3 conditions of Table 8.6.3 are satisfied, a START/STOP condition can be detected.

Note: When a STOP condition is detected in the slave mode (MST = 0), an interrupt request signal "LICIRQ" is generated to the CPU.

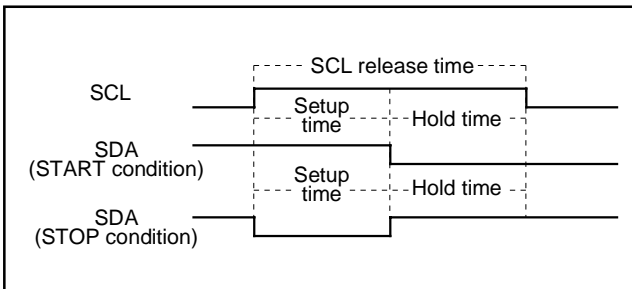

Fig. 8.6.11 START Condition/STOP Condition Detect Timing Diagram

Table 8.6.3 START Condition/STOP Condition Detect Conditions

Standard Clock Mode	High-speed Clock Mode
6.5 μs (26 cycles) < SCL release time	1.0 μs (4 cycles) < SCL release time
3.25 μs (13 cycles) < Setup time	0.5 μs (2 cycles) < Setup time
3.25 μs (13 cycles) < Hold time	0.5 μs (2 cycles) < Hold time

Note: Absolute time at φ = 4 MHz. The value in parentheses denotes the number of φ cycles.

8.6.9 Address Data Communication

There are two address data communication formats, namely, 7-bit addressing format and 10-bit addressing format. The respective address communication formats is described below.

(1) 7-bit addressing format

To meet the 7-bit addressing format, set the 10BIT SAD bit of the I²C control register (address 00F9₁₆) to "0." The first 7-bit address data transmitted from the master is compared with the high-order 7-bit slave address stored in the I²C address register (address 00F7₁₆). At the time of this comparison, address comparison of the RBW bit of the I²C address register (address 00F7₁₆) is not made. For the data transmission format when the 7-bit addressing format is selected, refer to Figure 8.6.12, (1) and (2).

(2) 10-bit addressing format

To meet the 10-bit addressing format, set the 10BIT SAD bit of the I²C control register (address 00F9₁₆) to "1." An address comparison is made between the first-byte address data transmitted from the master and the 7-bit slave address stored in the I²C address register (address 00F7₁₆). At the time of this comparison, an address comparison between the RBW bit of the I²C address register (address 00F7₁₆) and the R/W bit which is the last bit of the address data transmitted from the master is made. In the 10-bit addressing mode, the R/W bit which is the last bit of the address data not only specifies the direction of communication for control data but also is processed as an address data bit.

When the first-byte address data matches the slave address, the AAS bit of the I²C status register (address 00F8₁₆) is set to "1." After the second-byte address data is stored into the I²C data shift register (address 00F6₁₆), make an address comparison between the second-byte data and the slave address by software. When the address data of the 2nd bytes matches the slave address, set the RBW bit of the I²C address register (address 00F7₁₆) to "1" by software. This processing can match the 7-bit slave address and R/W data, which are received after a RESTART condition is detected, with the value of the I²C address register (address 00F7₁₆). For the data transmission format when the 10-bit addressing format is selected, refer to Figure 8.6.12, (3) and (4).

M37272M6H/M8H/MAH/MFH-XXXSP/FP M37272E8SP/FP, M37272EFSP/FP

SINGLE-CHIP 8-BIT CMOS MICROCOMPUTER with CLOSED CAPTION DECODER
and ON-SCREEN DISPLAY CONTROLLER

8.6.10 Example of Master Transmission

An example of master transmission in the standard clock mode, at the SCL frequency of 100 kHz and in the ACK return mode is shown below.

- ① Set a slave address in the high-order 7 bits of the I²C address register (address 00F7₁₆) and "0" in the RBW bit.
- ② Set the ACK return mode and SCL = 100 kHz by setting "85₁₆" in the I²C clock control register (address 00FA₁₆).
- ③ Set "10₁₆" in the I²C status register (address 00F8₁₆) and hold the SCL at the HIGH.
- ④ Set a communication enable status by setting "48₁₆" in the I²C control register (address 00F9₁₆).
- ⑤ Set the address data of the destination of transmission in the high-order 7 bits of the I²C data shift register (address 00F6₁₆) and set "0" in the least significant bit.
- ⑥ Set "F0₁₆" in the I²C status register (address 00F8₁₆) to generate a START condition. At this time, an SCL for 1 byte and an ACK clock automatically occurs.
- ⑦ Set transmit data in the I²C data shift register (address 00F6₁₆). At this time, an SCL and an ACK clock automatically occurs.
- ⑧ When transmitting control data of more than 1 byte, repeat step ⑦.
- ⑨ Set "D0₁₆" in the I²C status register (address 00F8₁₆). After this, if ACK is not returned or transmission ends, a STOP condition will be generated.

8.6.11 Example of Slave Reception

An example of slave reception in the high-speed clock mode, at the SCL frequency of 400 kHz, in the ACK non-return mode, using the addressing format, is shown below.

- ① Set a slave address in the high-order 7 bits of the I²C address register (address 00F7₁₆) and "0" in the RBW bit.
- ② Set the no ACK clock mode and SCL = 400 kHz by setting "25₁₆" in the I²C clock control register (address 00FA₁₆).
- ③ Set "10₁₆" in the I²C status register (address 00F8₁₆) and hold the SCL at the HIGH.
- ④ Set a communication enable status by setting "48₁₆" in the I²C control register (address 00F9₁₆).
- ⑤ When a START condition is received, an address comparison is made.
- ⑥ •When all transmitted address are "0" (general call):
ADO of the I²C status register (address 00F8₁₆) is set to "1" and an interrupt request signal occurs.
•When the transmitted addresses match the address set in ①:
ASS of the I²C status register (address 00F8₁₆) is set to "1" and an interrupt request signal occurs.
•In the cases other than the above:
ADO and AAS of the I²C status register (address 00F8₁₆) are set to "0" and no interrupt request signal occurs.
- ⑦ Set dummy data in the I²C data shift register (address 00F6₁₆).
- ⑧ When receiving control data of more than 1 byte, repeat step ⑦.
- ⑨ When a STOP condition is detected, the communication ends.

M37272M6H/M8H/MAH/MFH-XXXSP/FP M37272E8SP/FP, M37272EFSP/FP

SINGLE-CHIP 8-BIT CMOS MICROCOMPUTER with CLOSED CAPTION DECODER
and ON-SCREEN DISPLAY CONTROLLER

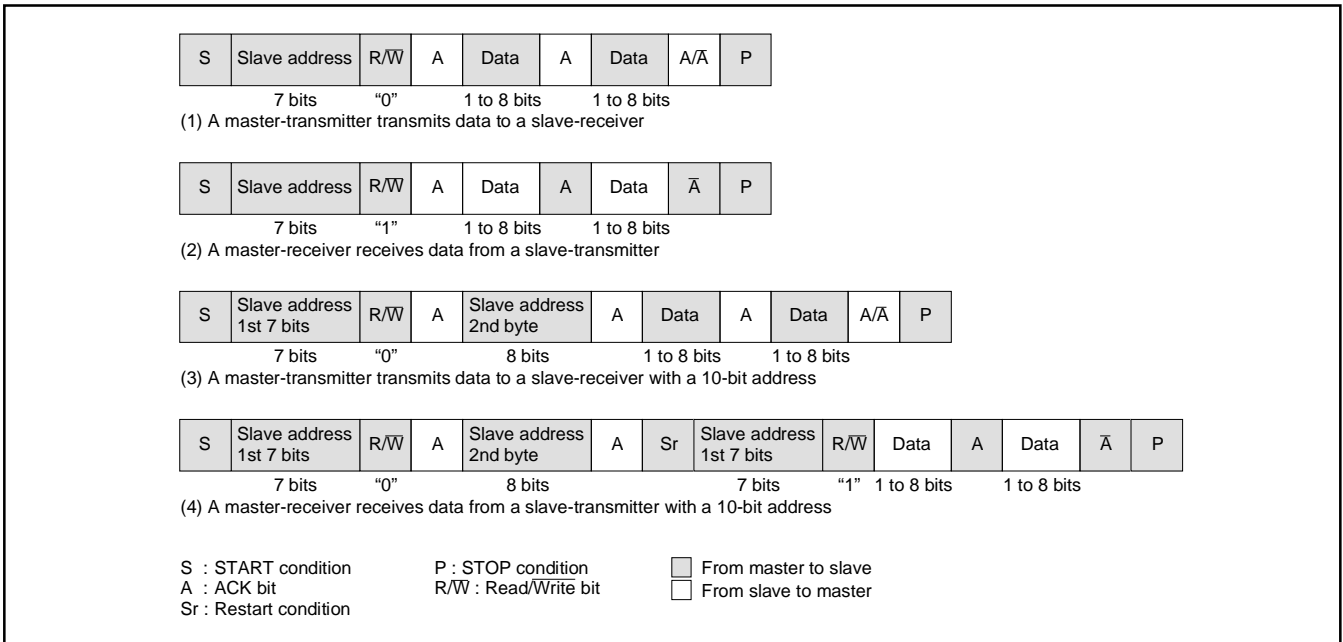

Fig. 8.6.12 Address Data Communication Format

8.6.12 Precautions when using multi-master I²C-BUS interface

(1) Read-modify-write instruction

The precautions when the read-modify-write instruction such as SEB, CLB etc. is executed for each register of the multi-master I²C-BUS interface are described below.

- I²C data shift register (S0)
When executing the read-modify-write instruction for this register during transfer, data may become a value not intended.
- I²C address register (S0D)
When the read-modify-write instruction is executed for this register at detecting the STOP condition, data may become a value not intended. It is because hardware changes the read/write bit (RBW) at the above timing.
- I²C status register (S1)
Do not execute the read-modify-write instruction for this register because all bits of this register are changed by hardware.
- I²C control register (S1D)
When the read-modify-write instruction is executed for this register at detecting the START condition or at completing the byte transfer, data may become a value not intended. Because hardware changes the bit counter (BC0-BC2) at the above timing.
- I²C clock control register (S2)
The read-modify-write instruction can be executed for this register.

(2) START condition generating procedure using multi-master

①Procedure example (The necessary conditions of the generating procedure are described as the following ② to ⑤).

```

•
•
LDA    —          (Taking out of slave address value)
SEI    (Interrupt disabled)
BBS    5,S1,BUSBUSY (BB flag confirming and branch process)
BUSFREE:
STA    S0          (Writing of slave address value)
LDM    #$F0, S1   (Trigger of START condition generating)
CLI    (Interrupt enabled)
•
•
BUSBUSY:
CLI    (Interrupt enabled)
•
•

```

- ②Use "STA," "STX" or "STY" of the zero page addressing instruction for writing the slave address value to the I²C data shift register.
- ③Use "LDM" instruction for setting trigger of START condition generating.
- ④Write the slave address value of above ② and set trigger of START condition generating of above ③ continuously shown the above procedure example.
- ⑤Disable interrupts during the following three process steps:
 - BB flag confirming
 - Writing of slave address value
 - Trigger of START condition generating
When the condition of the BB flag is bus busy, enable interrupts immediately.

M37272M6H/M8H/MAH/MFH-XXXSP/FP M37272E8SP/FP, M37272EFSP/FP

SINGLE-CHIP 8-BIT CMOS MICROCOMPUTER with CLOSED CAPTION DECODER
and ON-SCREEN DISPLAY CONTROLLER

(3) RESTART condition generating procedure

①Procedure example (The necessary conditions of the generating procedure are described as the following ② to ⑥.)

Execute the following procedure when the PIN bit is "0."

```

      •
      •
LDM  #$00, S1    (Select slave receive mode)
LDA  —          (Taking out of slave address value)
SEI  —          (Interrupt disabled)
STA  S0         (Writing of slave address value)
LDM  #$F0, S1   (Trigger of RESTART condition generating)
CLI  —          (Interrupt enabled)
      •
      •
    
```

②Select the slave receive mode when the PIN bit is "0." Do not write "1" to the PIN bit. Neither "0" nor "1" is specified for the writing to the BB bit.

The TRX bit becomes "0" and the SDA pin is released.

③The SCL pin is released by writing the slave address value to the I²C data shift register. Use "STA," "STX" or "STY" of the zero page addressing instruction for writing.

④Use "LDM" instruction for setting trigger of RESTART condition generating.

⑤Write the slave address value of above ③ and set trigger of RESTART condition generating of above ④ continuously shown the above procedure example.

⑥Disable interrupts during the following two process steps:

- Writing of slave address value
- Trigger of RESTART condition generating

(4) STOP condition generating procedure

①Procedure example (The necessary conditions of the generating procedure are described as the following ② to ④.)

```

      •
      •
SEI  —          (Interrupt disabled)
LDM  #$C0, S1   (Select master transmit mode)
NOP  —          (Set NOP)
LDM  #$D0, S1   (Trigger of STOP condition generating)
CLI  —          (Interrupt enabled)
      •
      •
    
```

②Write "0" to the PIN bit when master transmit mode is select.

③Execute "NOP" instruction after setting of master transmit mode. Also, set trigger of STOP condition generating within 10 cycles after selecting of master transmit mode.

④Disable interrupts during the following two process steps:

- Select of master transmit mode
- Trigger of STOP condition generating

(5) Writing to I²C status register

Do not execute an instruction to set the PIN bit to "1" from "0" and an instruction to set the MST and TRX bits to "0" from "1" simultaneously. It is because it may enter the state that the SCL pin is released and the SDA pin is released after about one machine cycle. Do not execute an instruction to set the MST and TRX bits to "0" from "1" simultaneously when the PIN bit is "1." It is because it may become the same as above.

(6) Process of after STOP condition generating

Do not write data in the I²C data shift register S0 and the I²C status register S1 until the bus busy flag BB becomes "0" after generating the STOP condition in the master mode. It is because the STOP condition waveform might not be normally generated. Reading to the above registers do not have the problem.

M37272M6H/M8H/MAH/MFH-XXXSP/FP M37272E8SP/FP, M37272EFSP/FP

SINGLE-CHIP 8-BIT CMOS MICROCOMPUTER with CLOSED CAPTION DECODER
and ON-SCREEN DISPLAY CONTROLLER

8.7 PWM OUTPUT FUNCTION

This microcomputer is equipped with six 8-bit PWMs (PWM0–PWM5). PWM0–PWM5 have the same circuit structure and an 8-bit resolution with minimum resolution bit width of $4\ \mu\text{s}$ (for $f(\text{XIN}) = 8\ \text{MHz}$) and repeat period of $1024\ \mu\text{s}$ (for $f(\text{XIN}) = 8\ \text{MHz}$).

Figure 8.7.1 shows the PWM block diagram. The PWM timing generating circuit applies individual control signals to PWM0–PWM5 using $f(\text{XIN})$ divided by 2 as a reference signal.

8.7.1 Data Setting

When outputting PWM0–PWM5, set 8-bit output data to the PWM i register (i means 0 to 5; addresses 0200 $_{16}$ to 0205 $_{16}$).

8.7.2 Transmitting Data from Register to PWM circuit

Data transfer from the 8-bit PWM register to the 8-bit PWM circuit is executed at writing data to the register.

The signal output from the 8-bit PWM output pin corresponds to the contents of this register.

8.7.3 Operating of 8-bit PWM

The following explains PWM operation.

First, set the bit 0 of PWM mode register 1 (address 0208 $_{16}$) to “0” (at reset, bit 0 is already set to “0” automatically), so that the PWM count source is supplied.

PWM0–PWM5 are also used as pins P0 $_0$ –P0 $_5$. Set the corresponding bits of the port P0 direction register to “1” (output mode). And select each output polarity by bit 3 of PWM mode register 1 (address 0208 $_{16}$). Then, set bits 5 to 0 of PWM mode register 2 (address 0209 $_{16}$) to “1” (PWM output).

The PWM waveform is output from the PWM output pins by setting these registers.

Figure 17 shows the 8-bit PWM timing. One cycle (T) is composed of 256 (2^8) segments. The 8 kinds of pulses relative to the weight of each bit (bits 0 to 7), are output inside the circuit during 1 cycle. Refer to Figure 17 (a). The 8-bit PWM outputs waveform which is the logical sum (OR) of pulses corresponding to the contents of bits 0 to 7 of the 8-bit PWM register. Several examples are shown in Figure 17 (b). 256 kinds of output (HIGH area: 0/256 to 255/256) are selected by changing the contents of the PWM register. A length of entirely HIGH cannot be output, i.e. 256/256.

8.7.4 Output after Reset

At reset, the output of ports P0 $_0$ –P0 $_5$ is in the high-impedance state, and the contents of the PWM register and the PWM circuit are undefined. Note that after reset, the PWM output is undefined until setting the PWM register.

M37272M6H/M8H/MAH/MFH-XXXSP/FP M37272E8SP/FP, M37272EFSP/FP

SINGLE-CHIP 8-BIT CMOS MICROCOMPUTER with CLOSED CAPTION DECODER
and ON-SCREEN DISPLAY CONTROLLER

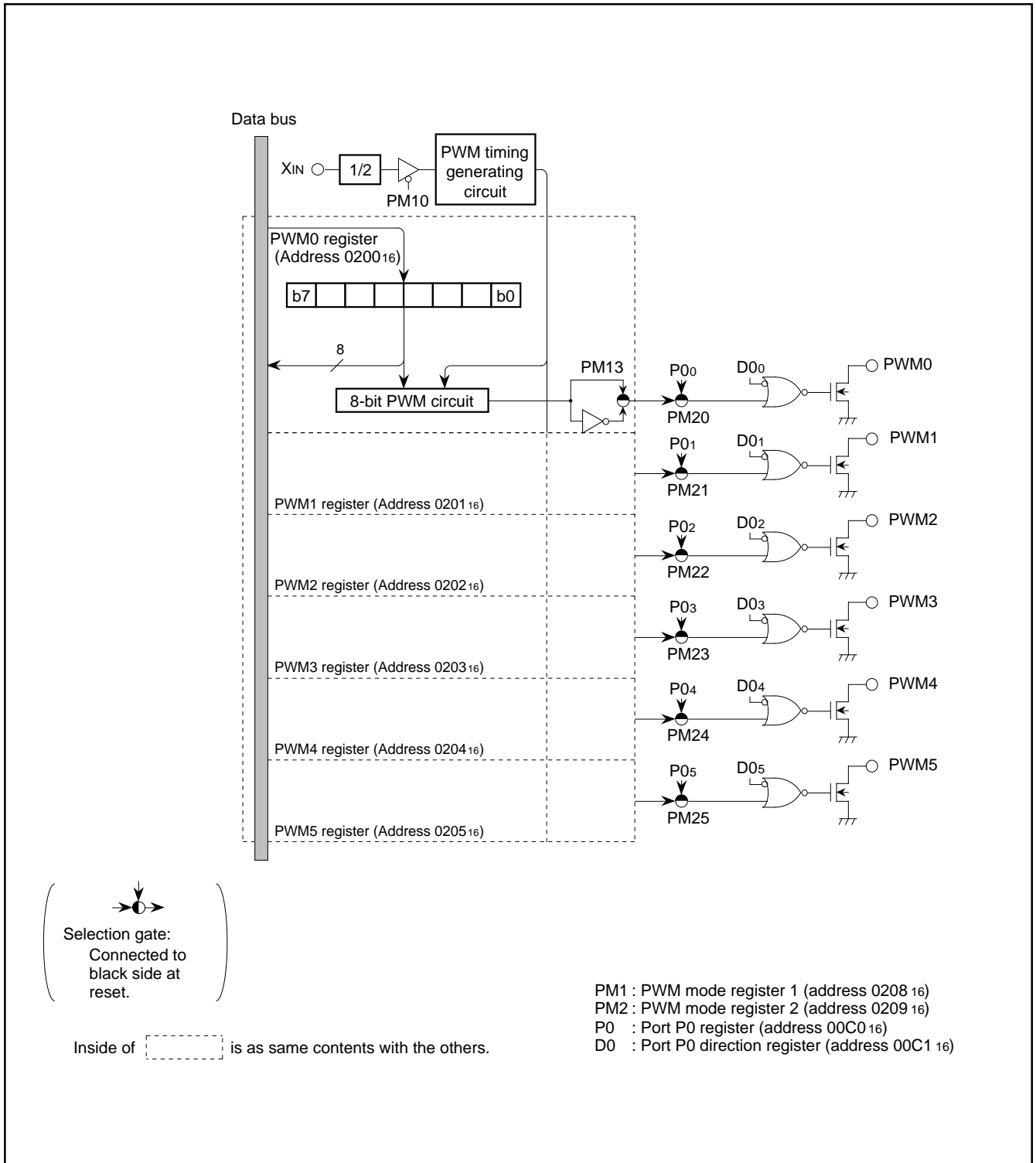

Fig. 8.7.1 PWM Block Diagram

M37272M6H/M8H/MAH/MFH-XXXSP/FP M37272E8SP/FP, M37272EFSP/FP

SINGLE-CHIP 8-BIT CMOS MICROCOMPUTER with CLOSED CAPTION DECODER
and ON-SCREEN DISPLAY CONTROLLER

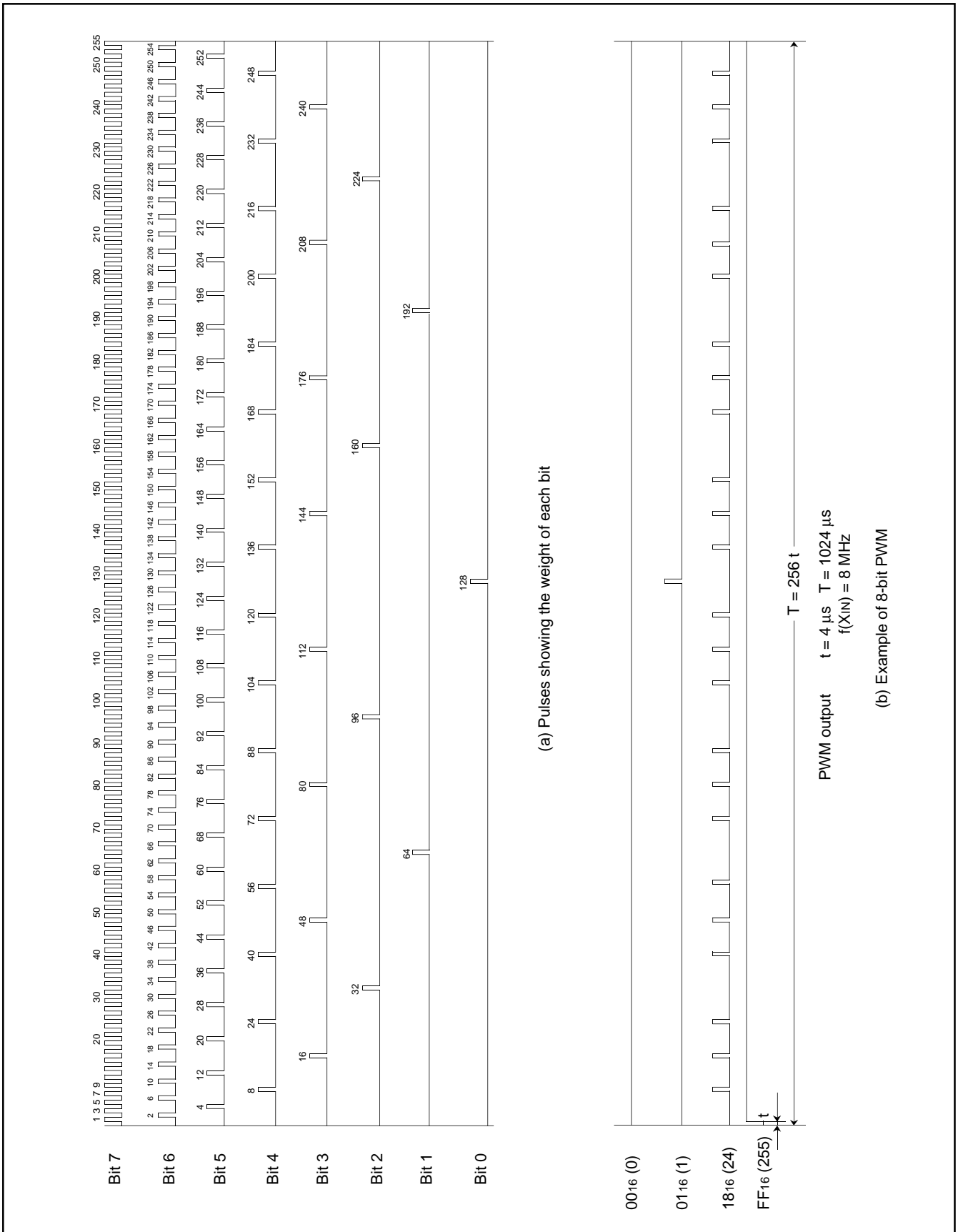

Fig. 8.7.2 PWM Timing

M37272M6H/M8H/MAH/MFH-XXXSP/FP M37272E8SP/FP, M37272EFSP/FP

SINGLE-CHIP 8-BIT CMOS MICROCOMPUTER with CLOSED CAPTION DECODER
and ON-SCREEN DISPLAY CONTROLLER

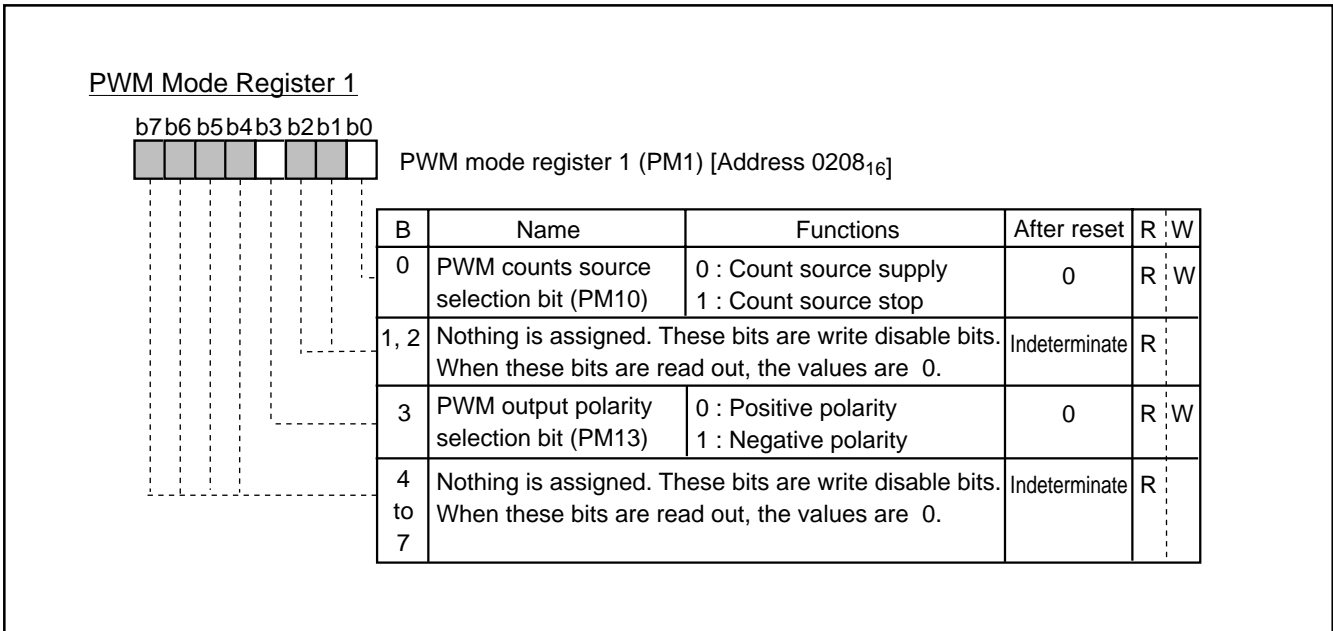

Fig. 8.7.3 PWM Mode Register 1

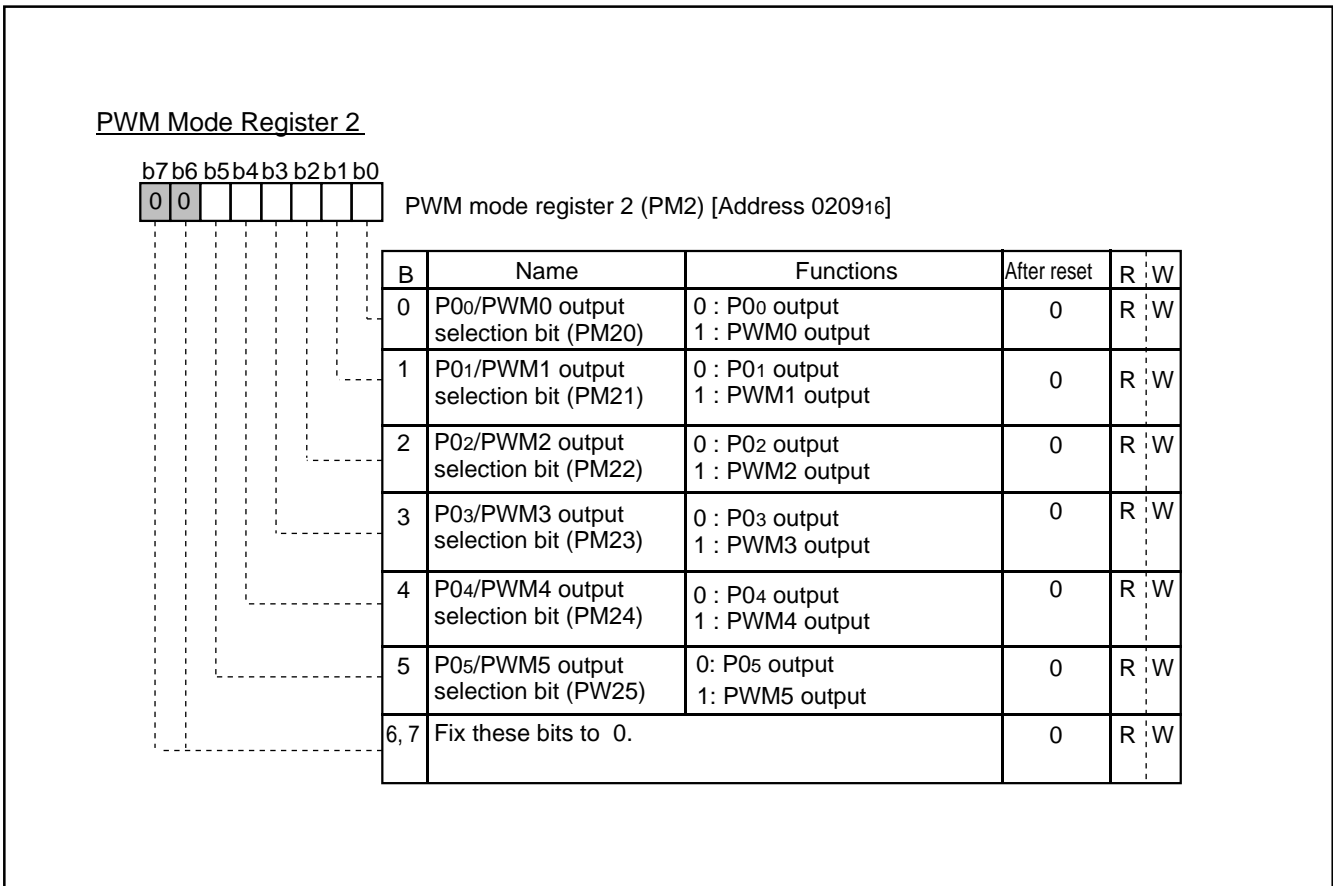

Fig. 8.7.4 PWM Mode Register 2

M37272M6H/M8H/MAH/MFH-XXXSP/FP M37272E8SP/FP, M37272EFSP/FP

SINGLE-CHIP 8-BIT CMOS MICROCOMPUTER with CLOSED CAPTION DECODER
and ON-SCREEN DISPLAY CONTROLLER

8.8 A-D COMPARATOR

A-D comparator consists of 6-bit D-A converter and comparator. A-D comparator block diagram is shown in Figure 8.8.1.

The reference voltage "V_{ref}" for D-A conversion is set by bits 0 to 5 of A-D control register 2 (address 00ED16).

The comparison result of the analog input voltage and the reference voltage "V_{ref}" is stored in bit 4 of A-D control register 1 (address 00EC16).

For A-D comparison, set "0" to corresponding bits of the direction register to use ports as analog input pins. Write the data for select of analog input pins to bits 0 to 2 of A-D control register 1 and write the digital value corresponding to V_{ref} to be compared to the bits 0 to 5 of A-D control register 2. The voltage comparison starts by writing to A-D control register 2, and it is completed after 16 machine cycles (NOP instruction X 8).

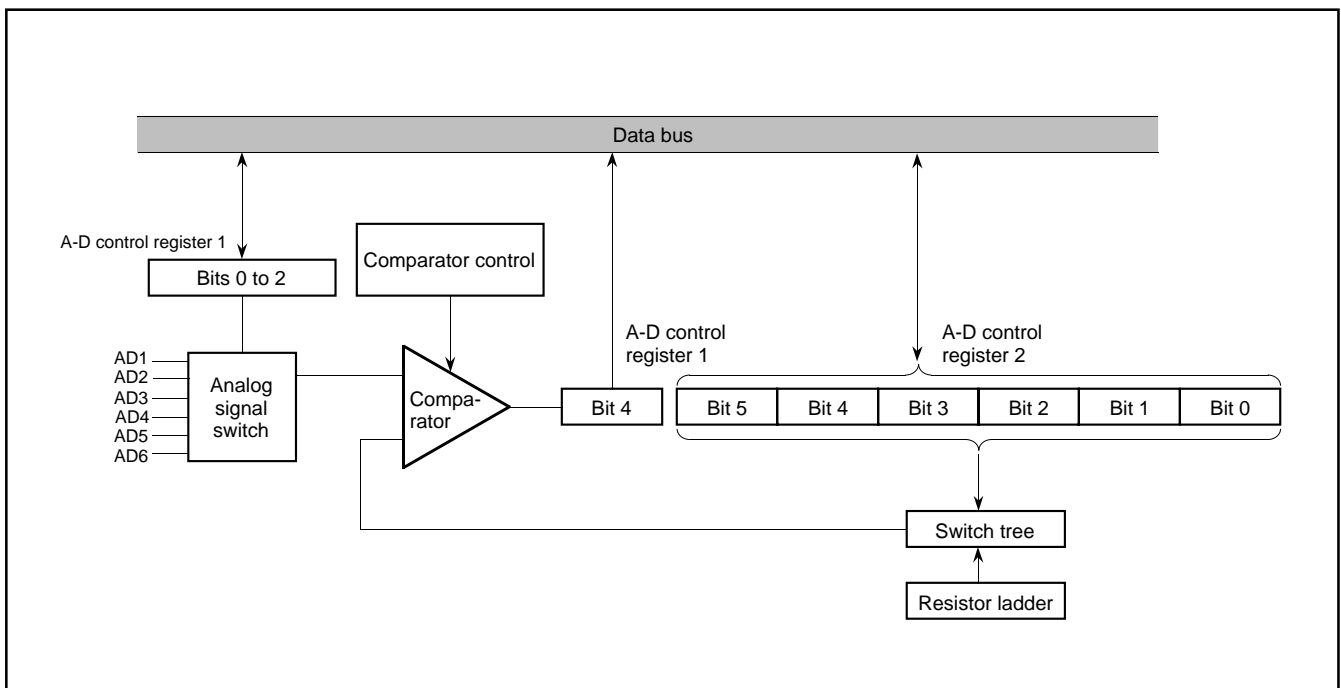

Fig. 8.8.1 A-D Comparator Block Diagram

M37272M6H/M8H/MAH/MFH-XXXSP/FP
M37272E8SP/FP, M37272EFSP/FP

SINGLE-CHIP 8-BIT CMOS MICROCOMPUTER with CLOSED CAPTION DECODER
 and ON-SCREEN DISPLAY CONTROLLER

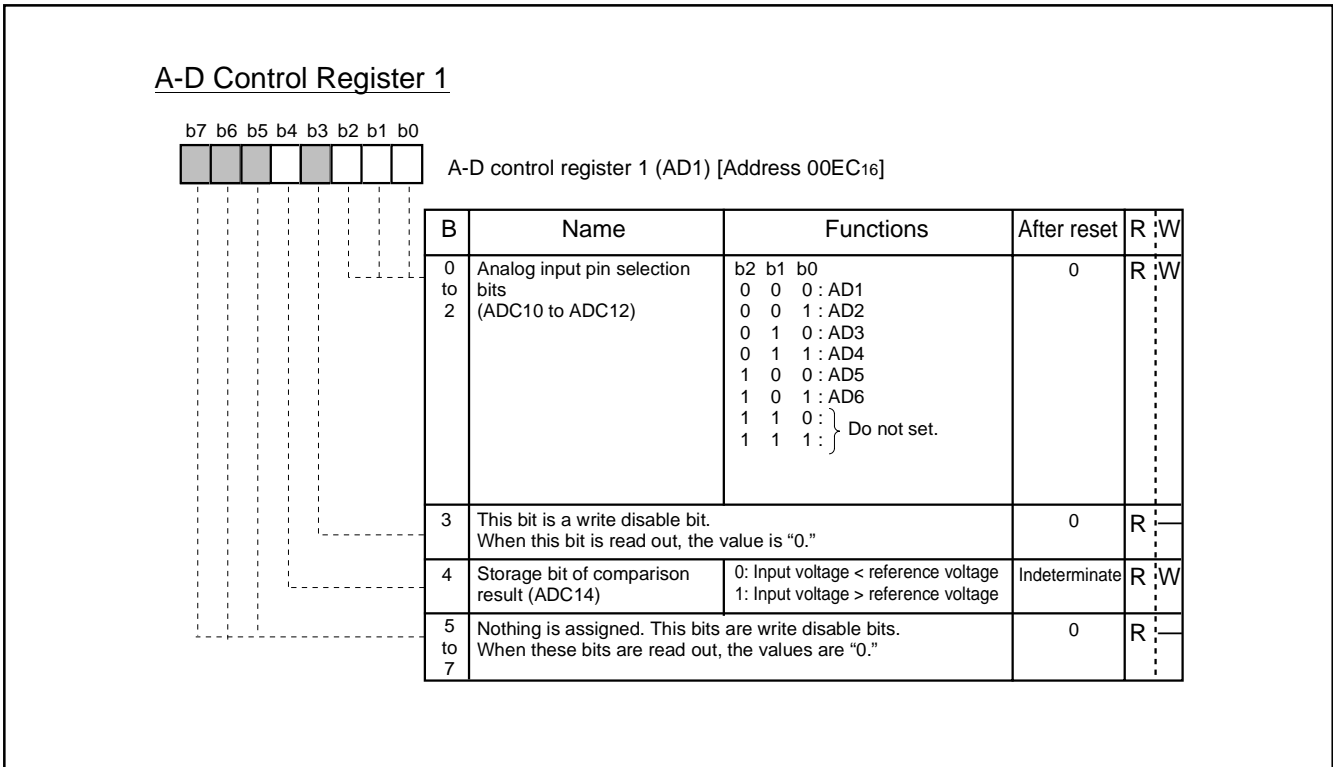

Fig. 8.8.2 A-D Control Register 1

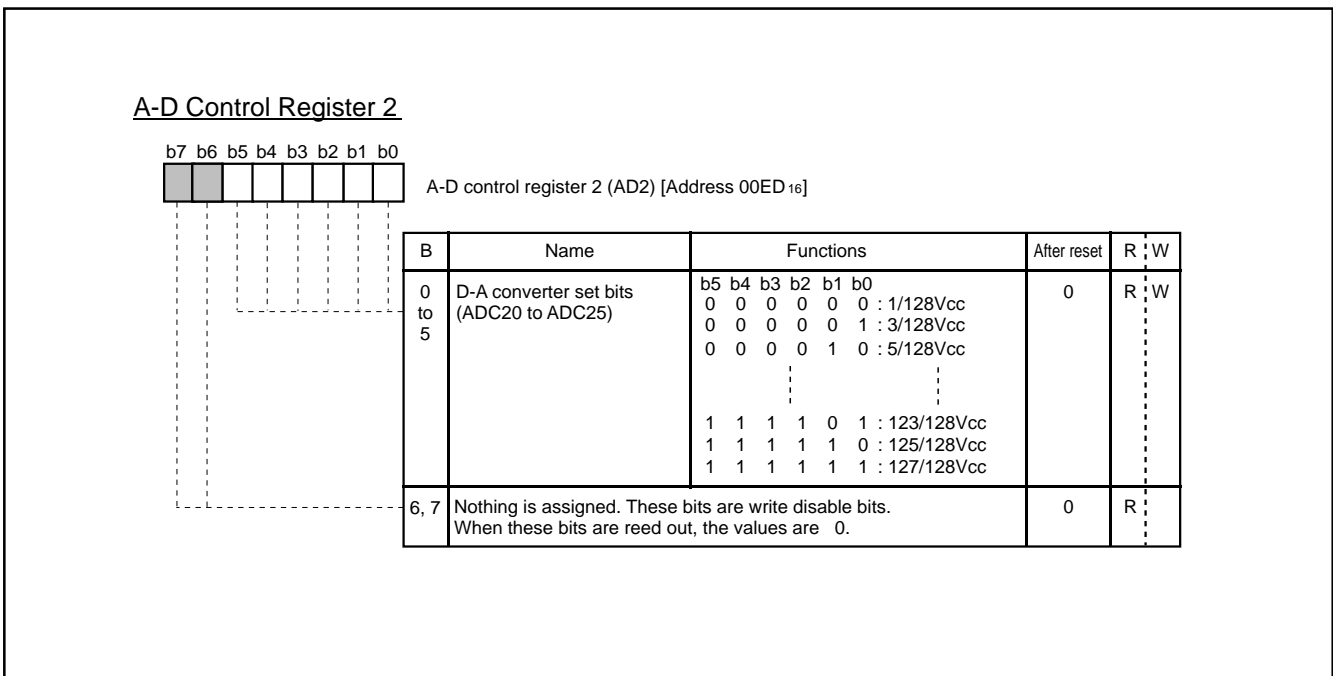

Fig. 8.8.3 A-D Control Register 2

M37272M6H/M8H/MAH/MFH-XXXSP/FP M37272E8SP/FP, M37272EFSP/FP

SINGLE-CHIP 8-BIT CMOS MICROCOMPUTER with CLOSED CAPTION DECODER
and ON-SCREEN DISPLAY CONTROLLER

8.9 ROM CORRECTION FUNCTION

This can correct program data in ROM. Up to 2 addresses can be corrected, a program for correction is stored in the ROM correction vector in RAM as the top address. The ROM correction vectors are 2 vectors.

Vector 1 : address 0300₁₆

Vector 2 : address 0320₁₆

Set the address of the ROM data to be corrected into the ROM correction address register. When the value of the counter matches the ROM data address in the ROM correction vector as the top address, the main program branches to the correction program stored in the ROM memory for correction. To return from the correction program to the main program, the op code and operand of the JMP instruction (total of 3 bytes) are necessary at the end of the correction program. The ROM correction function is controlled by the ROM correction enable register.

- Notes 1:** Specify the first address (op code address) of each instruction as the ROM correction address.
2: Use the JMP instruction (total of 3 bytes) to return from the correction program to the main program.
3: Do not set the same ROM correction address to vectors 1 and 2.

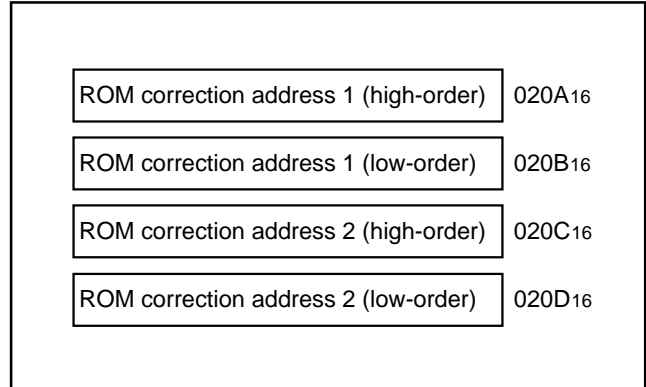

Fig. 8.9.1 ROM Correction Address Registers

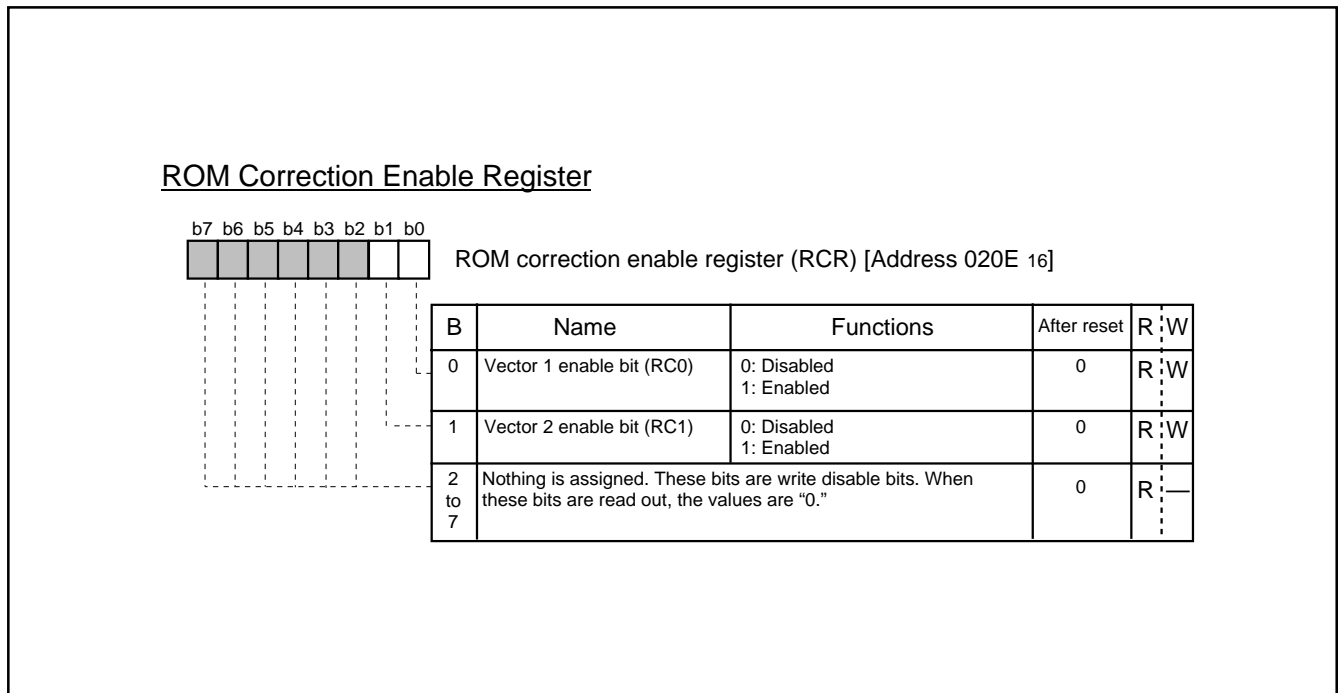

Fig. 8.9.2 ROM Correction Enable Register

M37272M6H/M8H/MAH/MFH-XXXSP/FP M37272E8SP/FP, M37272EFSP/FP

SINGLE-CHIP 8-BIT CMOS MICROCOMPUTER with CLOSED CAPTION DECODER and ON-SCREEN DISPLAY CONTROLLER

8.10 DATA SLICER

This microcomputer includes the data slicer function for the closed caption decoder (referred to as the CCD). This function takes out the caption data superimposed in the vertical blanking interval of a composite video signal. A composite video signal which makes the sync chip's polarity negative is input to the CV_{IN} pin.

When the data slicer function is not used, the data slicer circuit and the timing signal generating circuit can be cut off by setting bit 0 of the data slicer control register 1 (address 00E016) to "0." These settings can realize the low-power dissipation.

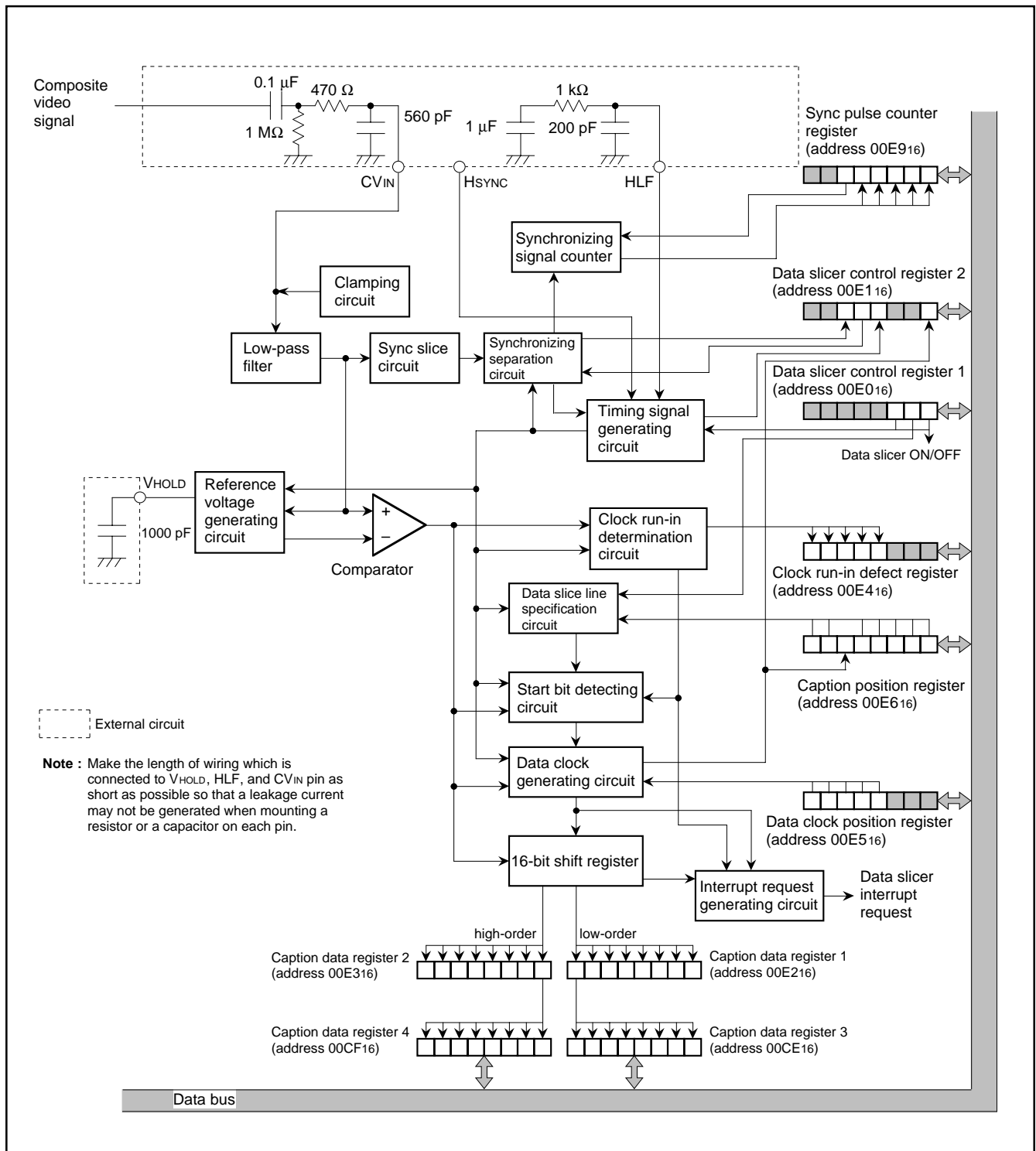

Fig. 8.10.1 Data Slicer Block Diagram

M37272M6H/M8H/MAH/MFH-XXXSP/FP
M37272E8SP/FP, M37272EFSP/FP

SINGLE-CHIP 8-BIT CMOS MICROCOMPUTER with CLOSED CAPTION DECODER
 and ON-SCREEN DISPLAY CONTROLLER

8.10.1 Notes When not Using Data Slicer

When bit 0 of data slicer control register 1 (address 00E016) is "0," terminate the pins as shown in Figure 8.10.2.

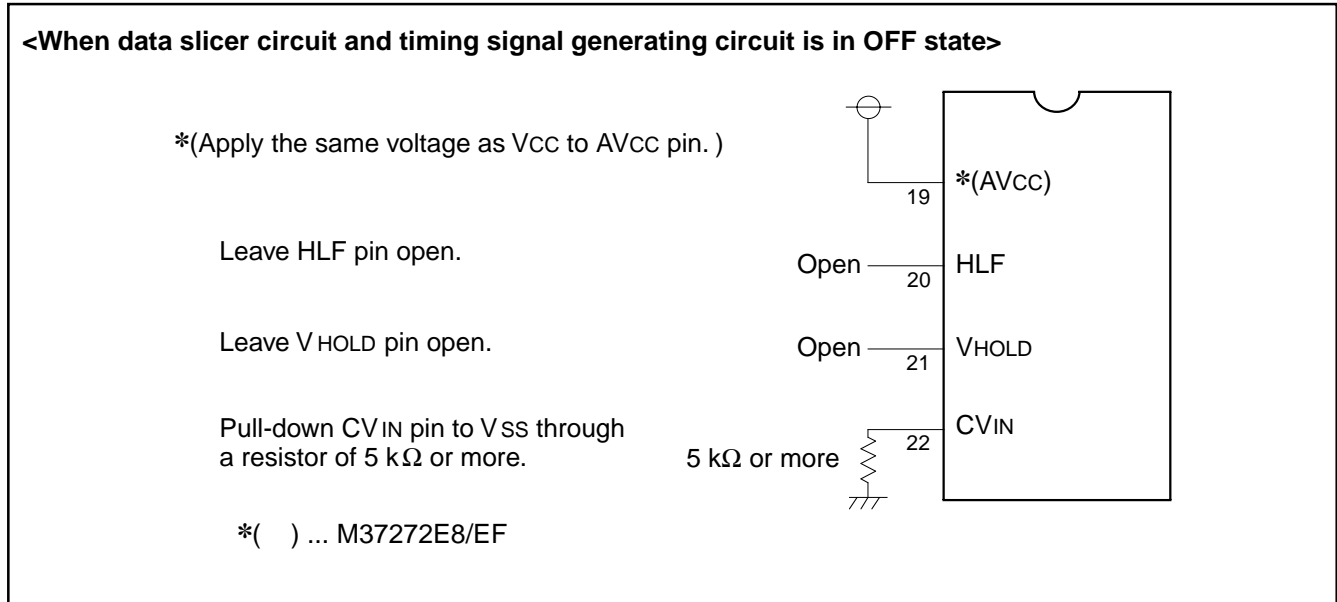

Fig. 8.10.2 Termination of Data Slicer Input/Output Pins when Data Slicer Circuit and Timing Generating Circuit Is in OFF State

When both bits 0 and 2 of data slicer control register 1 (address 00E016) are "1," terminate the pins as shown in Figure 8.10.3.

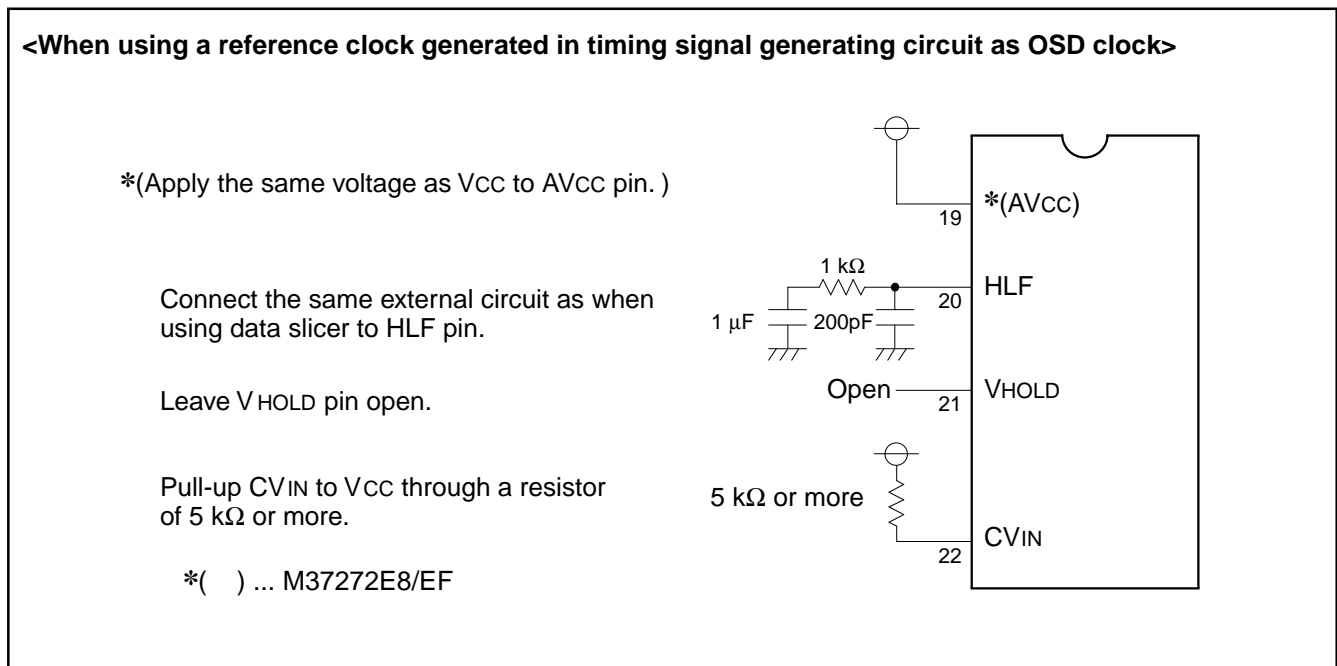

Fig. 8.10.3 Termination of Data Slicer Input/Output Pins when Timing Signal Generating Circuit Is in ON State

M37272M6H/M8H/MAH/MFH-XXXSP/FP M37272E8SP/FP, M37272EFSP/FP

SINGLE-CHIP 8-BIT CMOS MICROCOMPUTER with CLOSED CAPTION DECODER
and ON-SCREEN DISPLAY CONTROLLER

Figures 8.10.4 and 8.10.5 the data slicer control registers.

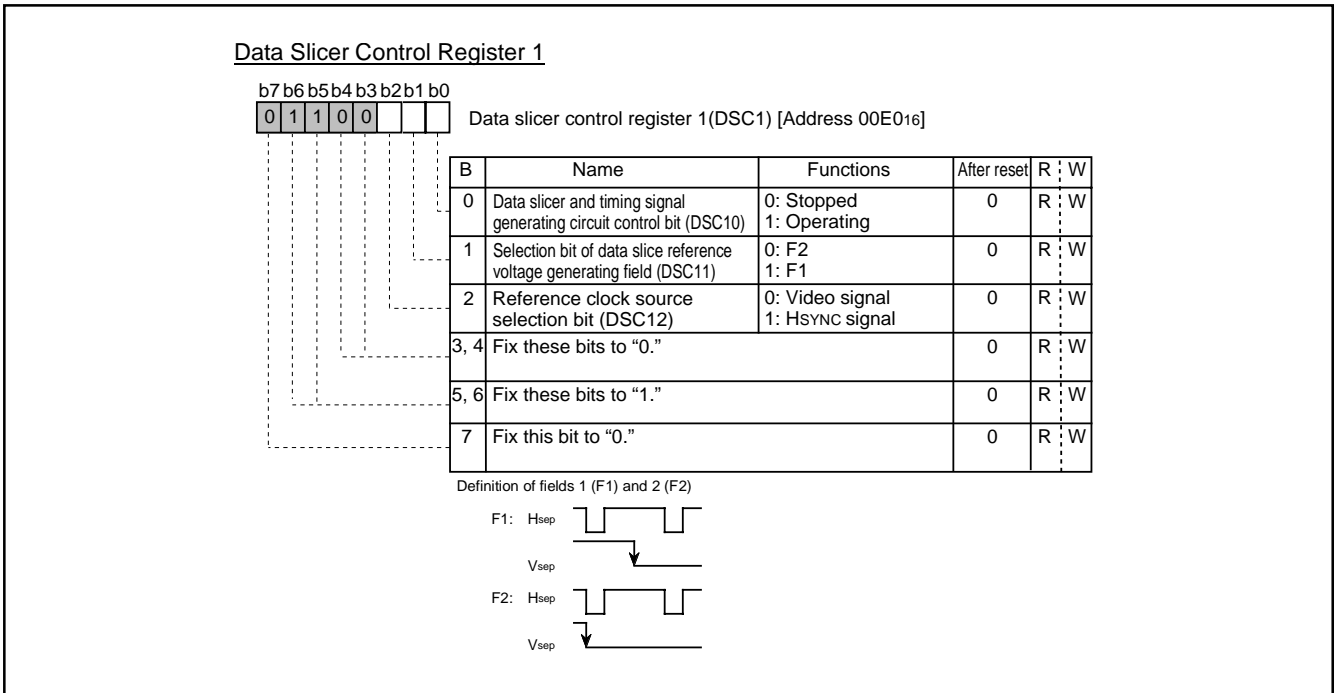

Fig. 8.10.4 Data Slicer Control Register 1

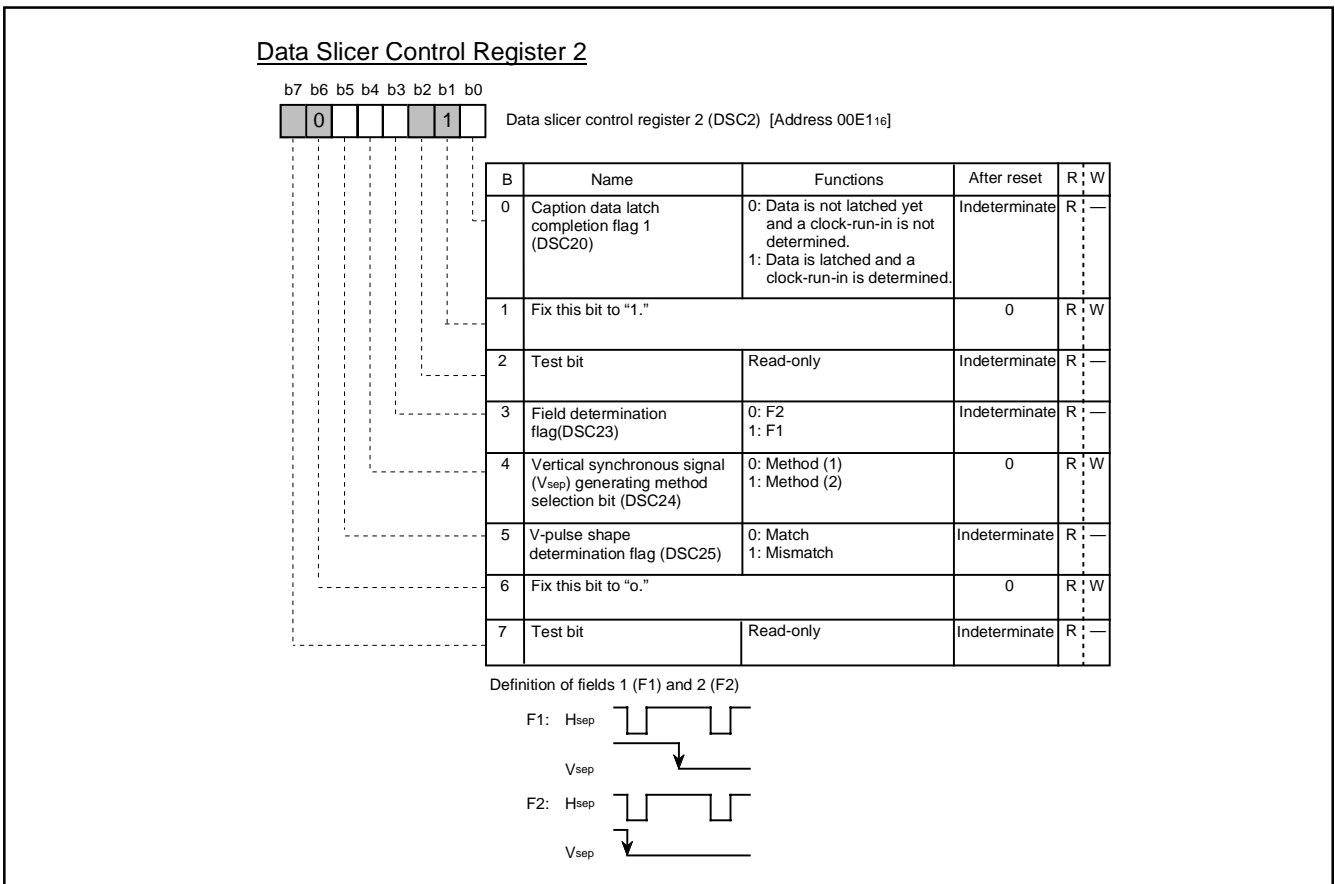

Fig. 8.10.5 Data Slicer Control Register 2

M37272M6H/M8H/MAH/MFH-XXXSP/FP M37272E8SP/FP, M37272EFSP/FP

SINGLE-CHIP 8-BIT CMOS MICROCOMPUTER with CLOSED CAPTION DECODER
and ON-SCREEN DISPLAY CONTROLLER

8.10.2 Clamping Circuit and Low-pass Filter

The clamp circuit clamps the sync chip part of the composite video signal input from the CVIN pin. The low-pass filter attenuates the noise of clamped composite video signal. The CVIN pin to which composite video signal is input requires a capacitor (0.1 μ F) coupling outside. Pull down the CVIN pin with a resistor of hundreds of kilohms to 1 M Ω . In addition, we recommend to install externally a simple low-pass filter using a resistor and a capacitor at the CVIN pin (refer to Figure 8.10.1).

8.10.3 Sync Slice Circuit

This circuit takes out a composite sync signal from the output signal of the low-pass filter.

8.10.4 Synchronous Signal Separation Circuit

This circuit separates a horizontal synchronous signal and a vertical synchronous signal from the composite sync signal taken out in the sync slice circuit.

(1) Horizontal Synchronous Signal (Hsep)

A one-shot horizontal synchronizing signal Hsep is generated at the falling edge of the composite sync signal.

(2) Vertical Synchronous Signal (Vsep)

As a Vsep signal generating method, it is possible to select one of the following 2 methods by using bit 4 of the data slicer control register 2 (address 00E116).

- Method 1 The LOW level width of the composite sync signal is measured. If this width exceeds a certain time, a Vsep signal is generated in synchronization with the rising of the timing signal immediately after this LOW level.
- Method 2 The LOW level width of the composite sync signal is measured. If this width exceeds a certain time, it is detected whether a falling of the composite sync signal exits or not in the LOW level period of the timing signal immediately after this LOW level. If a falling exists, a Vsep signal is generated in synchronization with the rising of the timing signal (refer to Figure 8.10.6).

Figure 8.10.6 shows a Vsep generating timing. The timing signal shown in the figure is generated from the reference clock which the timing generating circuit outputs.

Reading bit 5 of data slicer control register 2 permits determining the shape of the V-pulse portion of the composite sync signal. As shown in Figure 8.10.7, when the A level matches the B level, this bit is "0." In the case of a mismatch, the bit is "1."

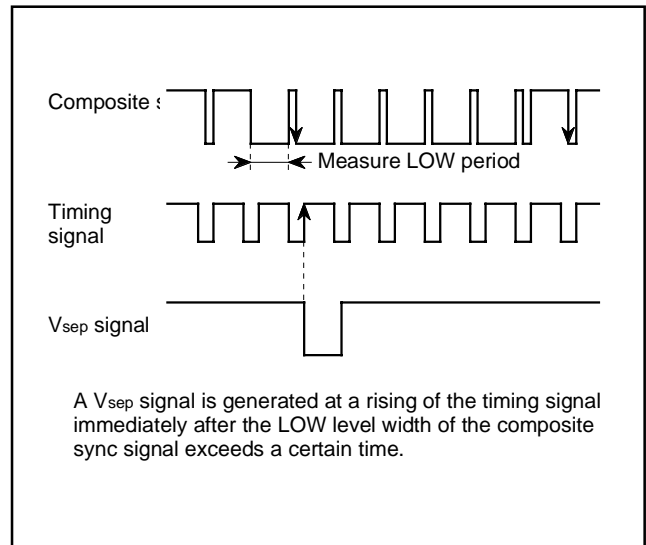

Fig. 8.10.6 Vsep Generating Timing (method 2)

M37272M6H/M8H/MAH/MFH-XXXSP/FP M37272E8SP/FP, M37272EFSP/FP

SINGLE-CHIP 8-BIT CMOS MICROCOMPUTER with CLOSED CAPTION DECODER
and ON-SCREEN DISPLAY CONTROLLER

8.10.5 Timing Signal Generating Circuit

This circuit generates a reference clock which is 832 times as large as the horizontal synchronous signal frequency. It also generates various timing signals on the basis of the reference clock, horizontal synchronous signal and vertical synchronizing signal. The circuit operates by setting bit 0 of data slicer control register 1 (address 00E016) to "1."

The reference clock can be used as a display clock for OSD function in addition to the data slicer. The HSYNC signal can be used as a count source instead of the composite sync signal. However, when the HSYNC signal is selected, the data slicer cannot be used. A count source of the reference clock can be selected by bit 2 of data slicer control register 1 (address 00E016).

For the pins HLF, connect a resistor and a capacitor as shown in Figure 8.10.1. Make the length of wiring which is connected to these pins as short as possible so that a leakage current may not be generated.

Note: It takes a few tens of milliseconds until the reference clock becomes stable after the data slicer and the timing signal generating circuit are started. In this period, various timing signals, H_{sep} signals and V_{sep} signals become unstable. For this reason, take stabilization time into consideration when programming.

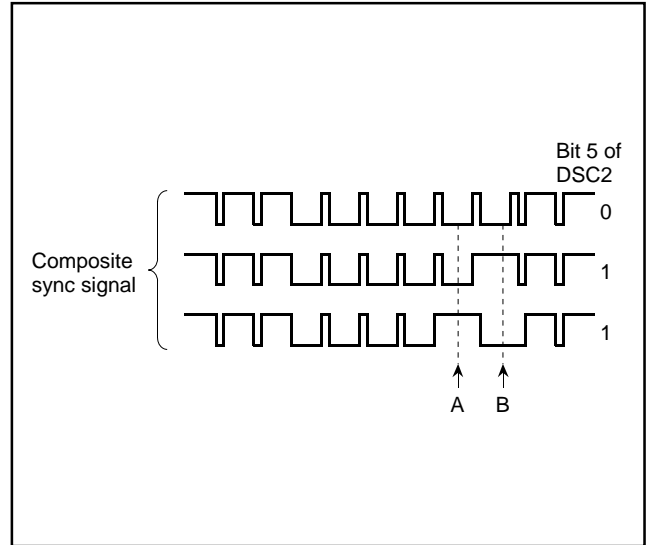

Fig. 8.10.7 Determination of V-pulse Waveform

M37272M6H/M8H/MAH/MFH-XXXSP/FP M37272E8SP/FP, M37272EFSP/FP

SINGLE-CHIP 8-BIT CMOS MICROCOMPUTER with CLOSED CAPTION DECODER
and ON-SCREEN DISPLAY CONTROLLER

8.10.6 Data Slice Line Specification Circuit

(1) Specification of data slice line

This circuit decides a line on which caption data is superimposed. The line 21 (fixed), 1 appropriate line for a period of 1 field (total 2 line for a period of 1 field), and both fields (F1 and F2) are sliced their data. The caption position register (address 00E616) is used for each setting (refer to Table 8.10.1).

The counter is reset at the falling edge of V_{sep} and is incremented by 1 every H_{sep} pulse. When the counter value matched the value specified by bits 4 to 0 of the caption position register, this H_{sep} is sliced.

The values of "0016" to "1F16" can be set in the caption position register (at setting only 1 appropriate line). Figure 8.10.8 shows the signals in the vertical blanking interval. Figure 8.10.9 shows the structure of the caption position register.

(2) Specification of line to set slice voltage

The reference voltage for slicing (slice voltage) is generated for the clock run-in pulse in the particular line (refer to Table 8.10.1). The field to generate slice voltage is specified by bit 1 of data slicer control register 1. The line to generate slice voltage 1 field is specified by bits 6, 7 of the caption position register (refer to Table 8.10.1).

(3) Field determination

The field determination flag can be read out by bit 3 of data slicer control register 2. This flag charge at the falling edge of V_{sep} .

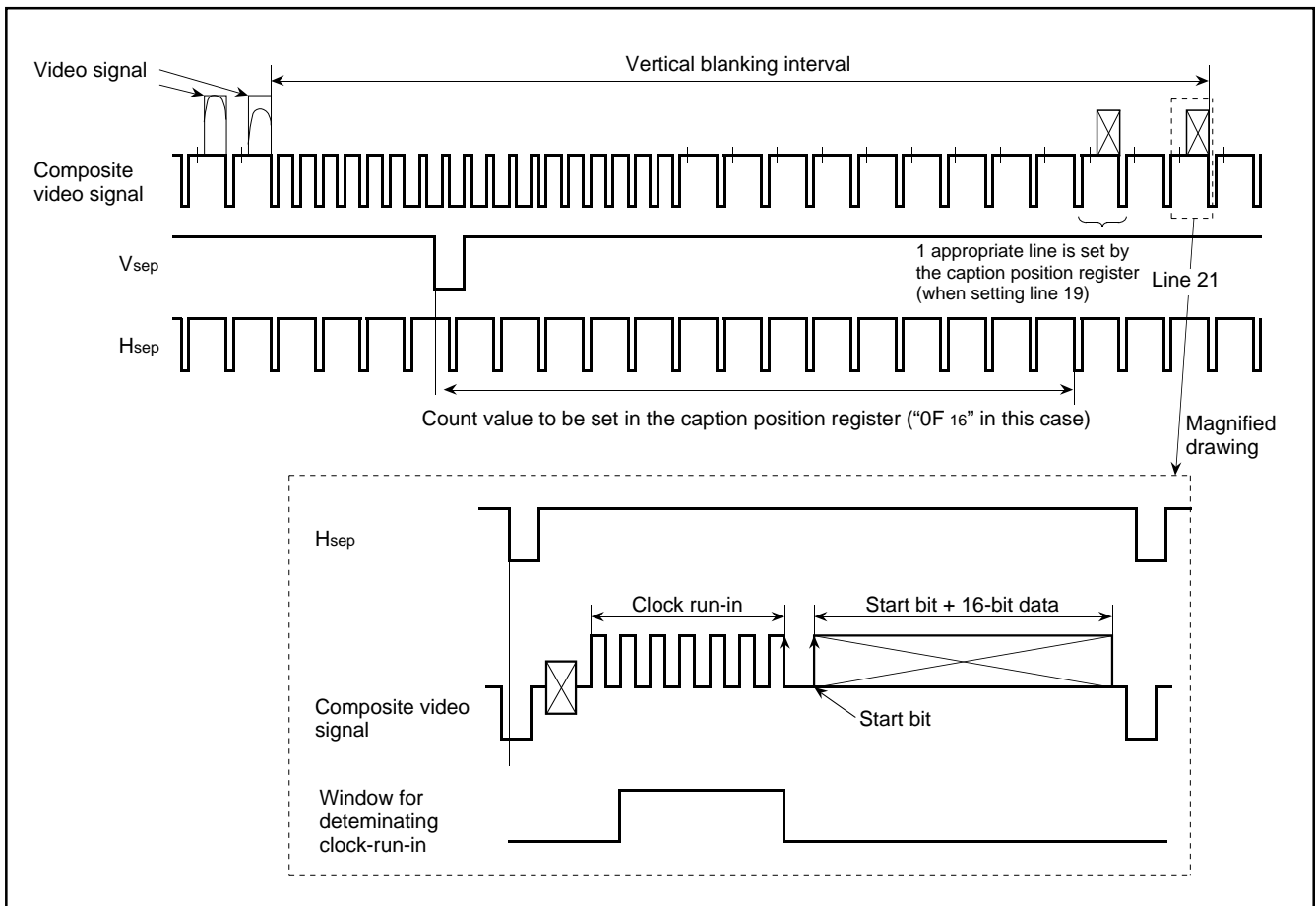

Fig. 8.10.8 Signals in Vertical Blanking Interval

M37272M6H/M8H/MAH/MFH-XXXSP/FP
M37272E8SP/FP, M37272EFSP/FP

SINGLE-CHIP 8-BIT CMOS MICROCOMPUTER with CLOSED CAPTION DECODER
 and ON-SCREEN DISPLAY CONTROLLER

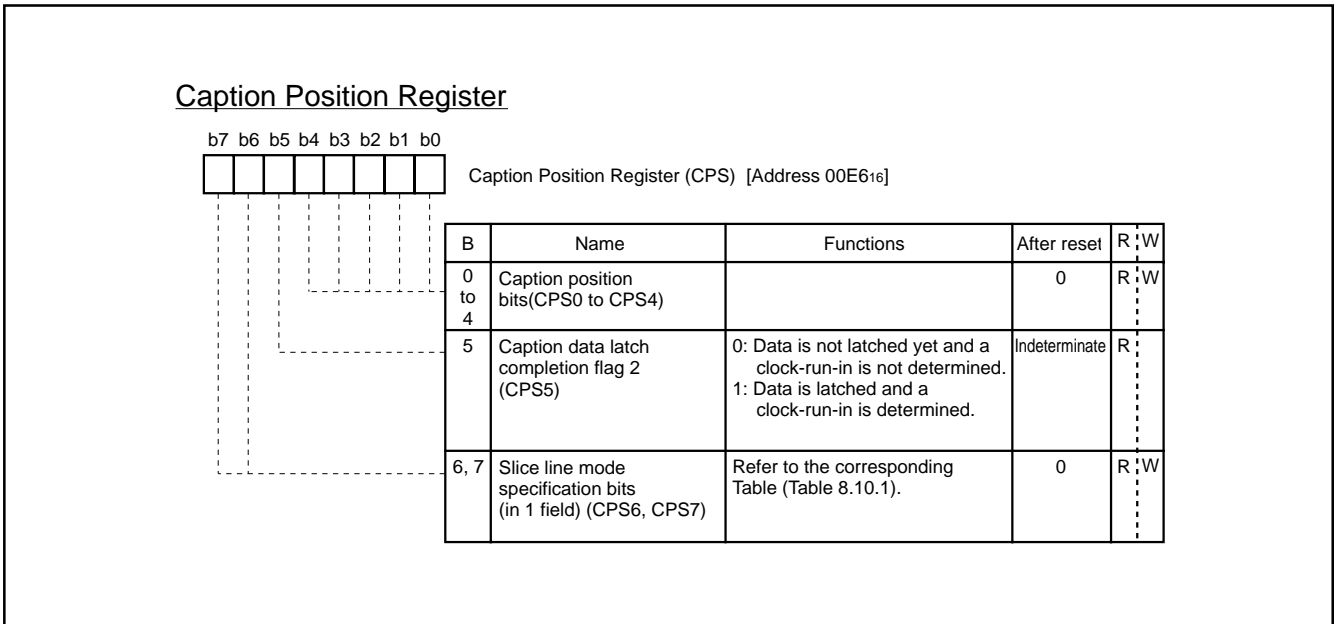

Fig. 8.10.9 Caption Position Register

Table 8.10.1 Specification of Data Slice Line

CPS		Field and Line to Be Sliced Data	Field and Line to Generate Slice Voltage
b7	b6		
0	0	<ul style="list-style-type: none"> Both fields of F1 and F2 Line 21 and a line specified by bits 4 to 0 of CPS (total 2 lines) (See note 2) 	<ul style="list-style-type: none"> Field specified by bit 1 of DSC1 Line 21 (total 1 line)
0	1	<ul style="list-style-type: none"> Both fields of F1 and F2 A line specified by bits 4 to 0 of CPS (total 1 line) (See note 3) 	<ul style="list-style-type: none"> Field specified by bit 1 of DSC1 A line specified by bits 4 to 0 of CPS (total 1 line) (See note 3)
1	0	<ul style="list-style-type: none"> Both fields of F1 and F2 Line 21 (total 1 line) 	<ul style="list-style-type: none"> Field specified by bit 1 of DSC1 Line 21 (total 1 line)
1	1	<ul style="list-style-type: none"> Both fields of F1 and F2 Line 21 and a line specified by bits 4 to 0 of CPS (total 2 lines) (See note 2) 	<ul style="list-style-type: none"> Field specified by bit 1 of DSC1 Line 21 and a line specified by bits 4 to 0 of CPS (total 2 lines) (See note 2)

Notes 1: DSC1 is data slicer control register 1.
 CPS is caption position register.
 2: Set "00₁₆" to "10₁₆" to bits 4 to 0 of CPS.
 3: Set "00₁₆" to "1F₁₆" to bits 4 to 0 of CPS.

M37272M6H/M8H/MAH/MFH-XXXSP/FP M37272E8SP/FP, M37272EFSP/FP

SINGLE-CHIP 8-BIT CMOS MICROCOMPUTER with CLOSED CAPTION DECODER
and ON-SCREEN DISPLAY CONTROLLER

8.10.7 Reference Voltage Generating Circuit and Comparator

The composite video signal clamped by the clamping circuit is input to the reference voltage generating circuit and the comparator.

(1) Reference voltage generating circuit

This circuit generates a reference voltage (slice voltage) by using the amplitude of the clock run-in pulse in line specified by the data slice line specification circuit. Connect a capacitor between the VHOLD pin and the VSS pin, and make the length of wiring as short as possible so that a leakage current may not be generated.

(2) Comparator

The comparator compares the voltage of the composite video signal with the voltage (reference voltage) generated in the reference voltage generating circuit, and converts the composite video signal into a digital value.

8.10.8 Start Bit Detecting Circuit

This circuit detects a start bit at line decided in the data slice line specification circuit.

The detection of a start bit is described below.

- ① A sampling clock is generated by dividing the reference clock output by the timing signal.
- ② A clock run-in pulse is detected by the sampling clock.
- ③ After detection of the pulse, a start bit pattern is detected from the comparator output.

8.10.9 Clock Run-in Determination Circuit

This circuit determinates clock run-in by counting the number of pulses in a window of the composite video signal.

The reference clock count value in one pulse cycle is stored in bits 3 to 7 of the clock run-in detect register (address 00E4₁₆). Read out these bits after the occurrence of a data slicer interrupt (refer to "8.10.12 Interrupt Request Generating Circuit").

Figure 8.10.10 shows the structure of clock run-in detect register.

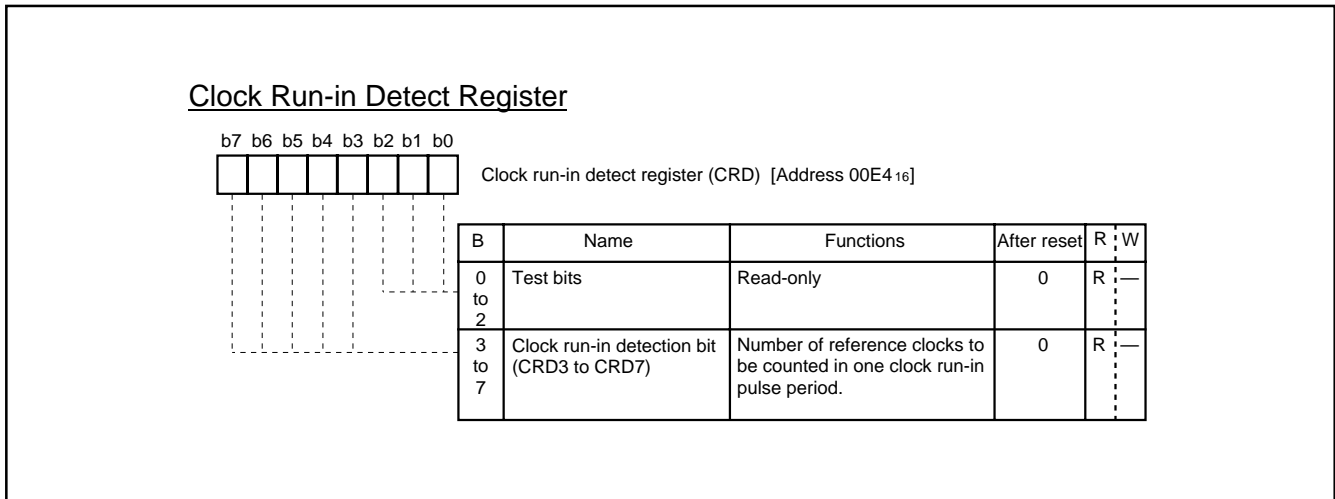

Fig. 8.10.10 Clock Run-in Detect Register

M37272M6H/M8H/MAH/MFH-XXXSP/FP M37272E8SP/FP, M37272EFSP/FP

SINGLE-CHIP 8-BIT CMOS MICROCOMPUTER with CLOSED CAPTION DECODER
and ON-SCREEN DISPLAY CONTROLLER

8.10.10 Data Clock Generating Circuit

This circuit generates a data clock synchronized with the start bit detected in the start bit detecting circuit. The data clock stores caption data to the 16-bit shift register. When the 16-bit data has been stored and the clock run-in determination circuit determines clock run-in, the caption data latch completion flag is set. This flag is reset at a falling of the vertical synchronous signal (Vsep).

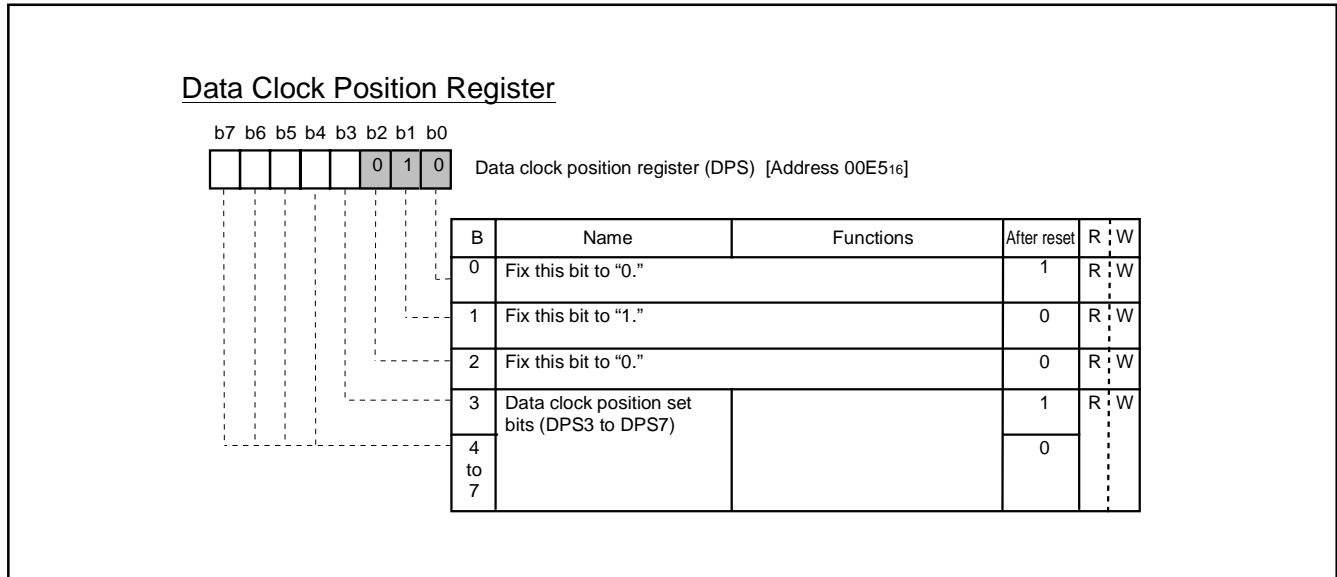

Fig. 8.10.11 Data Clock Position Register

M37272M6H/M8H/MAH/MFH-XXXSP/FP M37272E8SP/FP, M37272EFSP/FP

SINGLE-CHIP 8-BIT CMOS MICROCOMPUTER with CLOSED CAPTION DECODER
and ON-SCREEN DISPLAY CONTROLLER

8.10.11 16-bit Shift Register

The caption data converted into a digital value by the comparator is stored into the 16-bit shift register in synchronization with the data clock. The contents of the high-order 8 bits of the stored caption data can be obtained by reading out data register 2 (address 00E3₁₆) and data register 4 (address 00CF₁₆). The contents of the low-order 8 bits can be obtained by reading out data register 1 (address 00E2₁₆) and data register 3 (address 00CE₁₆), respectively. These registers are reset to "0" at a falling of V_{sep}. Read out data registers 1 and 2 after the occurrence of a data slicer interrupt (refer to "8.10.12 Interrupt Request Generating Circuit").

8.10.12 Interrupt Request Generating Circuit

The interrupt requests as shown in Table 8.10.3 are generated by combination of the following bits; bits 6 and 7 of the caption position register (address 00E6₁₆). Read out the contents of data registers 1 to 4 and the contents of bits 3 to 7 of the clock run-in detect register after the occurrence of a data slicer interrupt request.

Table 8.10.2 Contents of Caption Data Latch Completion Flag and 16-bit Shift Register

Slice Line Specification Mode		Contents of Caption Data Latch Completion Flag		Contents of 16-bit Shift Register	
CPS		Completion Flag 1 (bit 0 of DSC2)	Completion Flag 2 (bit 5 of CPS)	Caption Data Registers 1, 2	Caption Data Registers 3, 4
bit 7	bit 6				
0	0	Line 21	A line specified by bits 4 to 0 of CPS	16-bit data of line 21	16-bit data of a line specified by bits 4 to 0 of CPS
0	1	A line specified by bits 4 to 0 of CPS	Invalid	16-bit data of a line specified by bits 4 to 0 of CPS	Invalid
1	0	Line 21	Invalid	16-bit data of line 21	Invalid
1	1	Line 21	A line specified by bits 4 to 0 of CPS	16-bit data of line 21	16-bit data of a line specified by bits 4 to 0 of CPS

CPS: Caption position register
DSC2: Data slicer control register 2

Table 8.10.3 Occurrence Sources of Interrupt Request

Caption position register		Occurrence Sources of Interrupt Request at End of Data Slice Line
b7	b6	
0	0	After slicing line 21
	1	After a line specified by bits 4 to 0 of CPS
1	0	After slicing line 21
	1	After slicing line 21

M37272M6H/M8H/MAH/MFH-XXXSP/FP M37272E8SP/FP, M37272EFSP/FP

SINGLE-CHIP 8-BIT CMOS MICROCOMPUTER with CLOSED CAPTION DECODER
and ON-SCREEN DISPLAY CONTROLLER

8.10.13 Synchronous Signal Counter

The synchronous signal counter counts the composite sync signal taken out from a video signal in the data slicer circuit or the vertical synchronous signal V_{sep} as a count source.

The count value in a certain time (T time) generated by $f(X_{IN})/2^{13}$ or $f(X_{IN})/2^{13}$ is stored into the 5-bit latch. Accordingly, the latch value changes in the cycle of T time. When the count value exceeds "1F16," "1F16" is stored into the latch.

The latch value can be obtained by reading out the sync pulse counter register (address 00E916). A count source is selected by bit 5 of the sync pulse counter register.

The synchronous signal counter is used when bit 0 of PWM mode register 1 (address 020816).

Figure 8.10.12 shows the structure of the sync pulse counter and Figure 8.10.13 shows the synchronous signal counter block diagram.

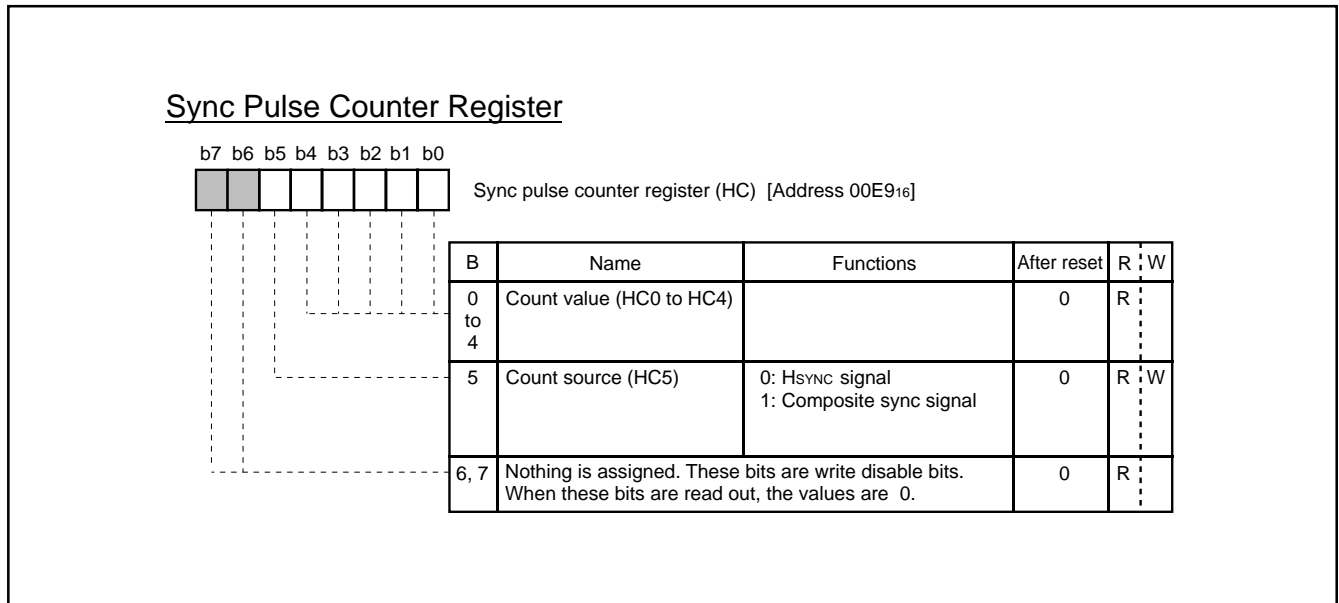

Fig. 8.10.12 Sync Pulse Counter Register

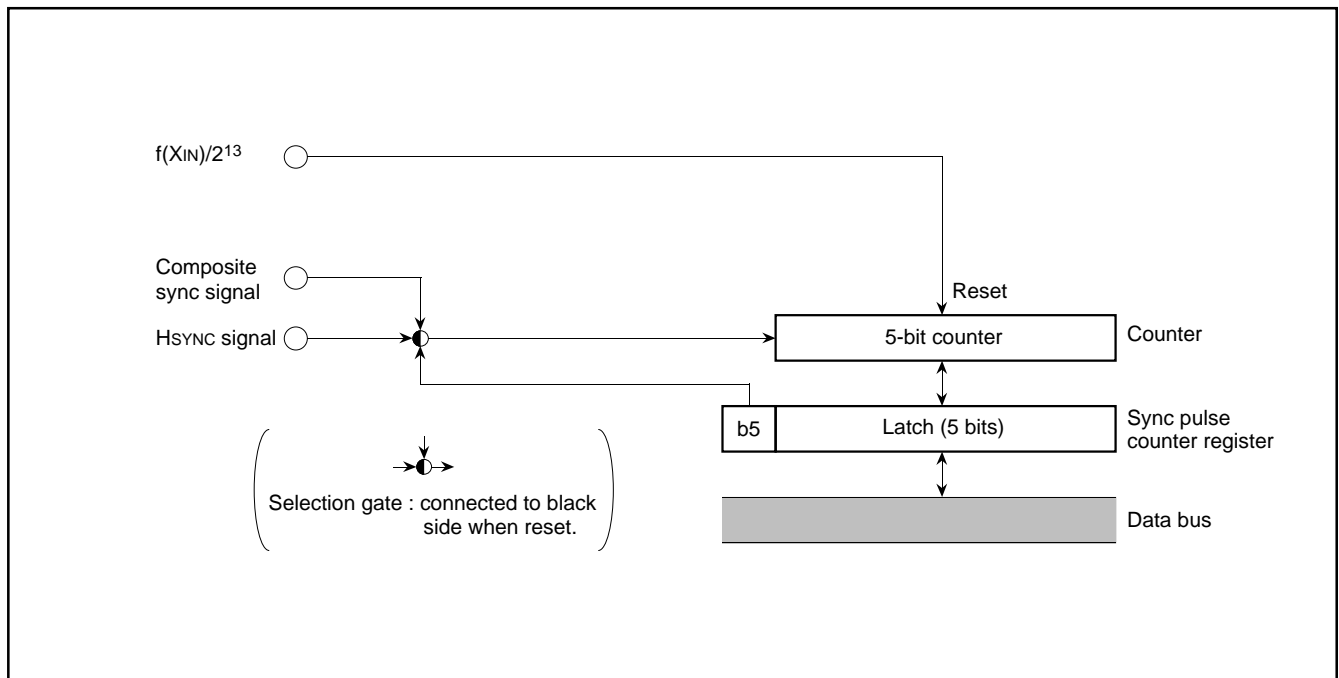

Fig. 8.10.13 Synchronous Signal Counter Block Diagram

M37272M6H/M8H/MAH/MFH-XXXSP/FP
M37272E8SP/FP, M37272EFSP/FP

SINGLE-CHIP 8-BIT CMOS MICROCOMPUTER with CLOSED CAPTION DECODER
 and ON-SCREEN DISPLAY CONTROLLER

8.11 OSD FUNCTIONS

Table 8.11.1 outlines the OSD functions.

This microcomputer incorporates an OSD circuit of 32 characters X 2 lines. And also, there are 2 display modes and they are selected by a block unit. The display modes are selected by bits 0 and 1 of block control register i (i = 1 and 2).

The features of each mode are described below.

Table 8.11.1 Features of Each Display Mode

Parameter	Display mode	
	CC mode (Closed caption mode)	OSD mode (Border OFF) (On-screen display mode)
Number of display characters	32 characters X 2 lines	
Dot structure	16 X 26 dots (Character display area : 16 X 20 dots)	16 X 20 dots
Kinds of characters	254 kinds	
Kinds of character sizes	1 kinds	8 kinds
Pre-divide ratio (See note)	X 2 (fixed)	X 2, X 3
Dot size	1Tc X 1/2H	1Tc X 1/2H, 1Tc X 1H, 2Tc X 2H, 3Tc X 3H
Attribute	Smooth italic, under line, flash	Border (black)
Character font coloring	1 screen : 8 kinds (per character unit)	
Character background coloring	_____	1 screen : 8 kinds (per character unit)
OSD output	R, G, B	
Raster coloring	Possible (per character unit)	
Function	Auto solid space function Window function	_____
Display position	Horizontal: 128 levels, Vertical: 512 levels	
Display expansion (multiline display)	Possible	

Notes 1: The divide ratio of the frequency divider (the pre-divide circuit) is referred as "pre-divide ratio" hereafter.

2: The character size is specified with dot size and pre-divide ratio (refer to 8.11.2 Dot Size).

M37272M6H/M8H/MAH/MFH-XXXSP/FP M37272E8SP/FP, M37272EFSP/FP

SINGLE-CHIP 8-BIT CMOS MICROCOMPUTER with CLOSED CAPTION DECODER
and ON-SCREEN DISPLAY CONTROLLER

The OSD circuit has an extended display mode. This mode allows multiple lines (3 lines or more) to be displayed on the screen by interrupting the display each time one line is displayed and rewriting data in the block for which display is terminated by software.

Figure 8.11.1 shows the configuration of OSD character. Figure 8.11.2 shows the block diagram of the OSD circuit. Figure 8.11.3 shows the OSD control register. Figure 8.11.4 shows the block control register i.

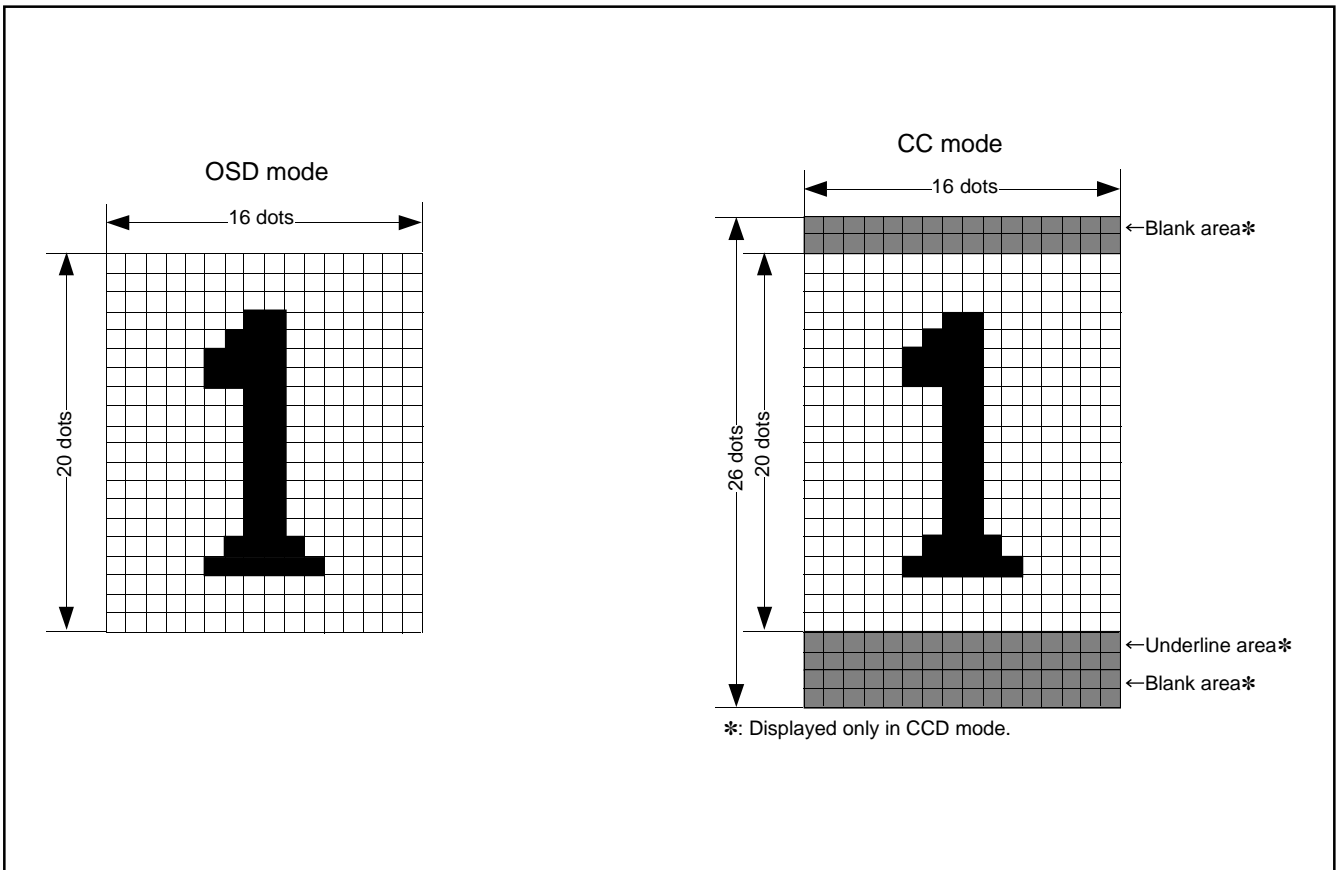

Fig. 8.11.1 Configuration of OSD Character Display Area

M37272M6H/M8H/MAH/MFH-XXXSP/FP
M37272E8SP/FP, M37272EFSP/FP

SINGLE-CHIP 8-BIT CMOS MICROCOMPUTER with CLOSED CAPTION DECODER
 and ON-SCREEN DISPLAY CONTROLLER

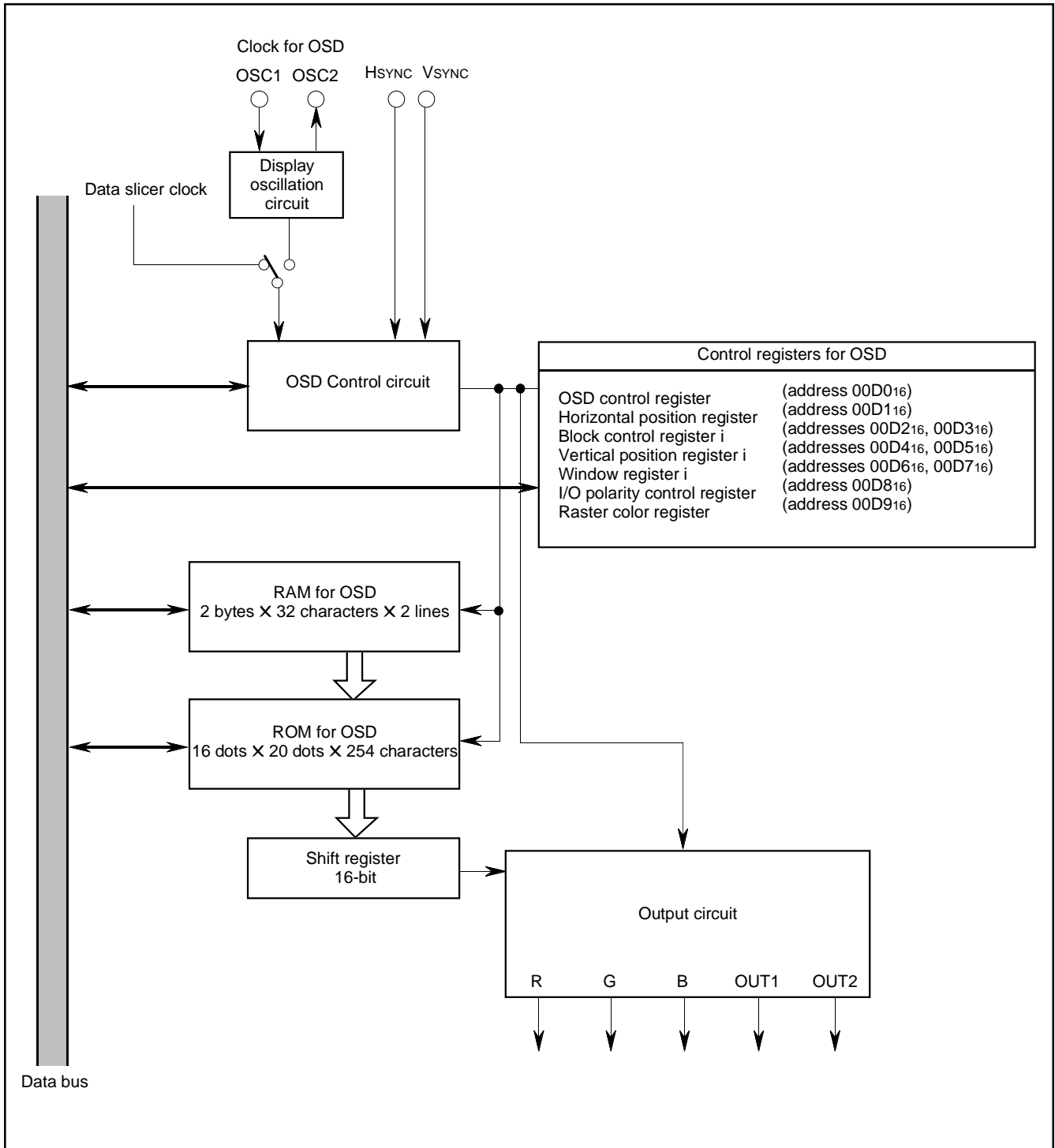
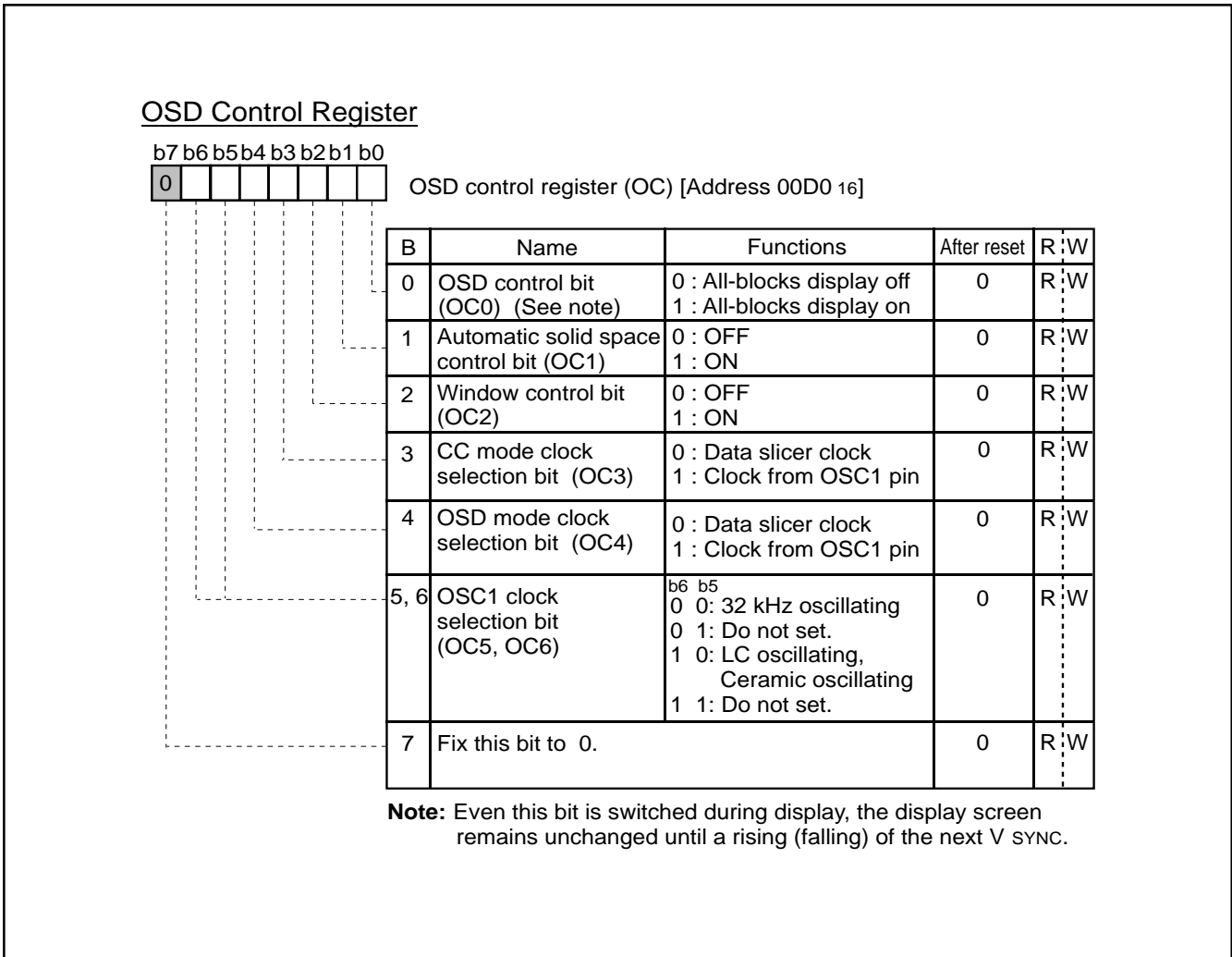

Fig. 8.11.2 Block Diagram of OSD Circuit

M37272M6H/M8H/MAH/MFH-XXXSP/FP
M37272E8SP/FP, M37272EFSP/FP

SINGLE-CHIP 8-BIT CMOS MICROCOMPUTER with CLOSED CAPTION DECODER
 and ON-SCREEN DISPLAY CONTROLLER



Note: Even this bit is switched during display, the display screen remains unchanged until a rising (falling) of the next V SYNC.

Fig. 8.11.3 OSD Control Register

M37272M6H/M8H/MAH/MFH-XXXSP/FP
M37272E8SP/FP, M37272EFSP/FP

SINGLE-CHIP 8-BIT CMOS MICROCOMPUTER with CLOSED CAPTION DECODER
 and ON-SCREEN DISPLAY CONTROLLER

Block Control register i

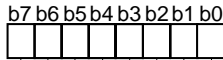

Block control register i (BCi) (i=1, 2) [Addresses 00D2 16 and 00D3 16]

B	Name	Functions	After reset	R	W
0, 1	Display mode selection bits (BCi0, BCi1) (See note 1)	b1 b0 0 0: Display OFF 0 1: CC mode 1 0: OSD mode (Border OFF) 1 1: OSD mode (Border ON)	Indeterminate	R	W
2, 3	Dot size selection bits (BCi2, BCi3)	b4 b3 b2 Pre-divide Ratio Dot Size 0 0 0 X 2 1Tc X 1/2H 0 0 1 1Tc X 1H 1 0 0 2Tc X 2H 1 1 1 3Tc X 3H	Indeterminate	R	W
4	Pre-divide ratio selection bit (BCi4)	b4 b3 b2 Pre-divide Ratio Dot Size 0 0 0 X 3 1Tc X 1/2H 0 0 1 1Tc X 1H 1 1 0 2Tc X 2H 1 1 1 3Tc X 3H	Indeterminate	R	W
5	OUT1/OUT2 output control bit (BCi5) (See note 1)	0: OUT1 output control 1: OUT2 output control	Indeterminate	R	W
6	Vertical display start position control bit (BCi6)	BC16: Block 1 BC26: Block 1	Indeterminate	R	W
7	Window top/bottom boundary control bit (BCi7)	BC17: Window top boundary BC27: Window bottom boundary	Indeterminate	R	W

Notes 1: Bit RA3 of OSD RAM controls OUT1 output when bit 5 is "0."
 Bit RA3 of OSD RAM controls OUT2 output when bit 5 is "1."
2: Tc is OSD clock cycle divided in pre-divide circuit.
3: H is HSYNC.

Fig. 8.11.4 Block Control Register i

M37272M6H/M8H/MAH/MFH-XXXSP/FP M37272E8SP/FP, M37272EFSP/FP

SINGLE-CHIP 8-BIT CMOS MICROCOMPUTER with CLOSED CAPTION DECODER
and ON-SCREEN DISPLAY CONTROLLER

8.11.1 Display Position

The display positions of characters are specified in units called a "block." There are 2 blocks, blocks 1 and 2. Up to 32 characters can be displayed in each block (refer to "8.11.5 Memory for OSD").

The display position of each block can be set in both horizontal and vertical directions by software.

The display start position in the horizontal direction can be selected for all blocks in common from 128-step display positions in units of 4Tosc (Tosc = OSD oscillation cycle).

The display start position in the vertical direction for each block can be selected from 512-step display positions in units of 1 TH (TH = HSYNC cycle).

Blocks are displayed in conformance with the following rules:

- When the display position of block 1 is overlapped with that of block 2 (Figure 8.11.5 (b)), the block 1 is displayed on the front.
- When another block display position appears while one block is displayed (Figure 8.11.5 (c)), the block with a larger set value as the vertical display start position is displayed.

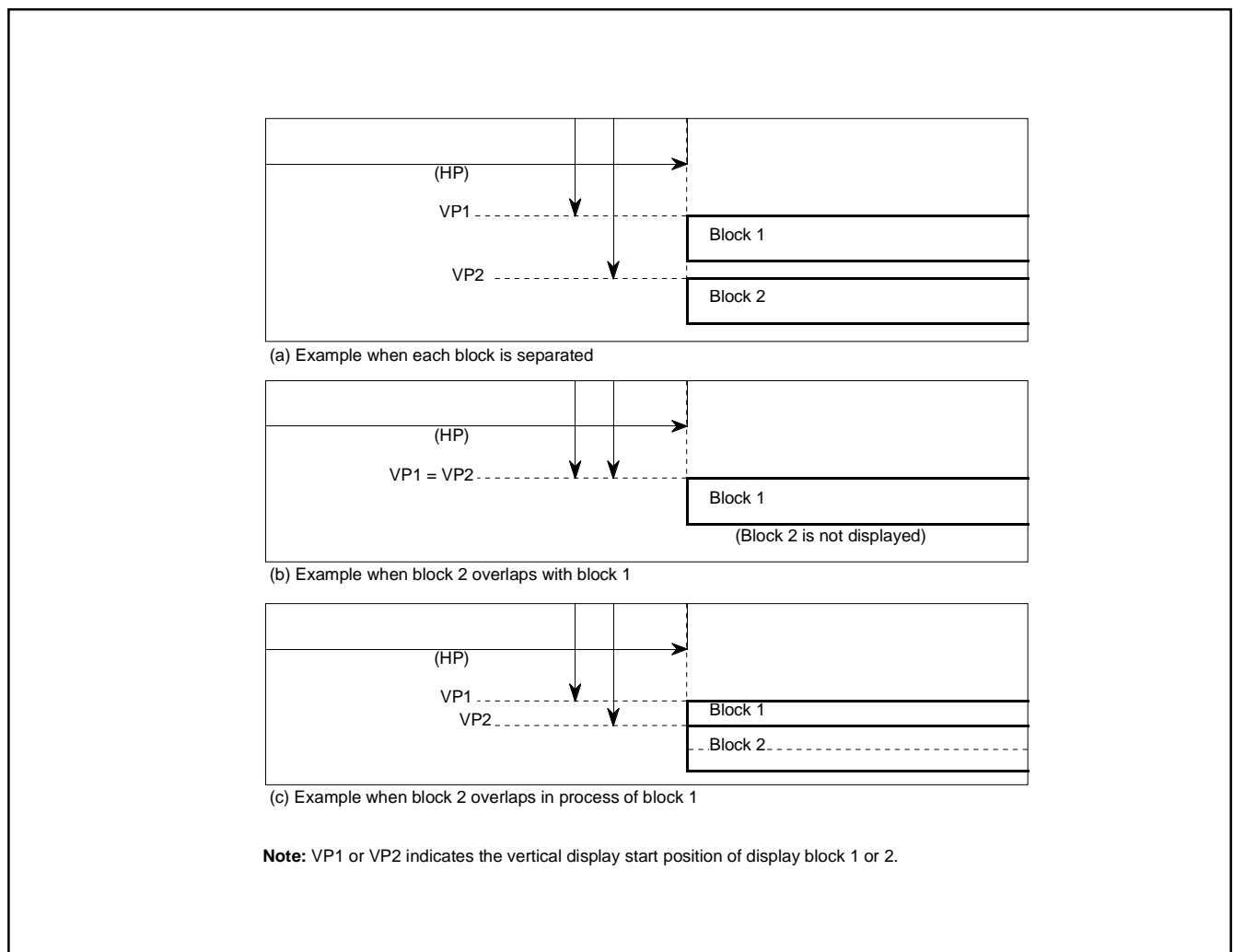

Fig. 8.11.5 Display Position

M37272M6H/M8H/MAH/MFH-XXXSP/FP
M37272E8SP/FP, M37272EFSP/FP

SINGLE-CHIP 8-BIT CMOS MICROCOMPUTER with CLOSED CAPTION DECODER
 and ON-SCREEN DISPLAY CONTROLLER

The vertical display start position is determined by counting the horizontal sync signal (HSYNC). At this time, when VSYNC and HSYNC are positive polarity (negative polarity), it starts to count the rising edge (falling edge) of HSYNC signal from after fixed cycle of rising edge (falling edge) of VSYNC signal. So interval from rising edge (falling edge) of VSYNC signal to rising edge (falling edge) of HSYNC signal needs enough time (2 machine cycles or more) for avoiding jitter. The polarity of HSYNC and VSYNC signals can select with the I/O polarity control register (address 00D816).

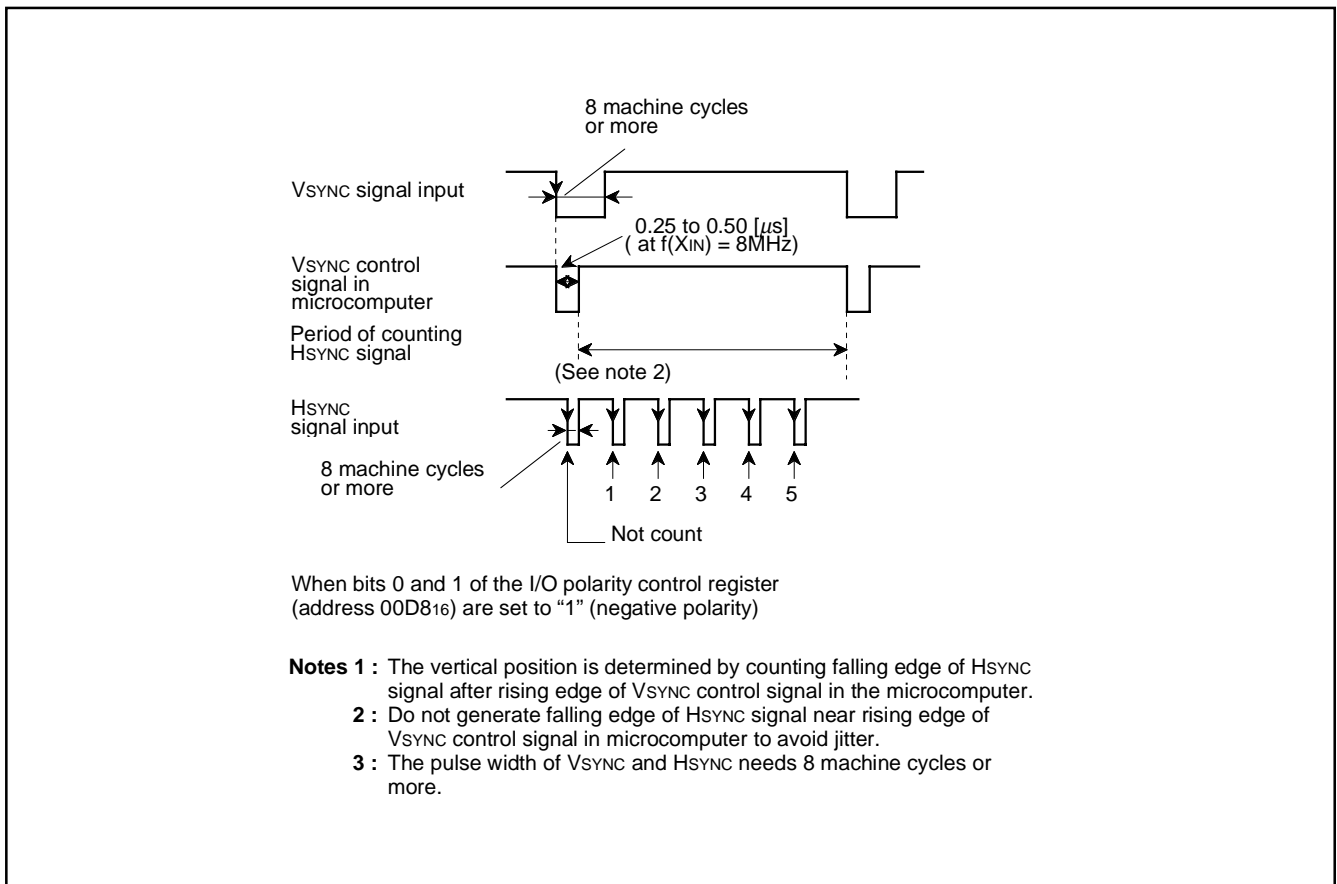

Fig. 8.11.6 Supplement Explanation for Display Position

M37272M6H/M8H/MAH/MFH-XXXSP/FP
M37272E8SP/FP, M37272EFSP/FP

SINGLE-CHIP 8-BIT CMOS MICROCOMPUTER with CLOSED CAPTION DECODER
 and ON-SCREEN DISPLAY CONTROLLER

The vertical display start position for each block can be set in 512 steps (where each step is 1TH (TH: Hsync cycle)) as values "0016" to "FF16" in vertical position register i (i = 1 and 2) (addresses 00D416 and 00D516) and values "0" or "1" in bit 6 of block control register i (i = 1 and 2) (addresses 00D216 and 00D316). The vertical position registers is shown in Figure 8.11.7.

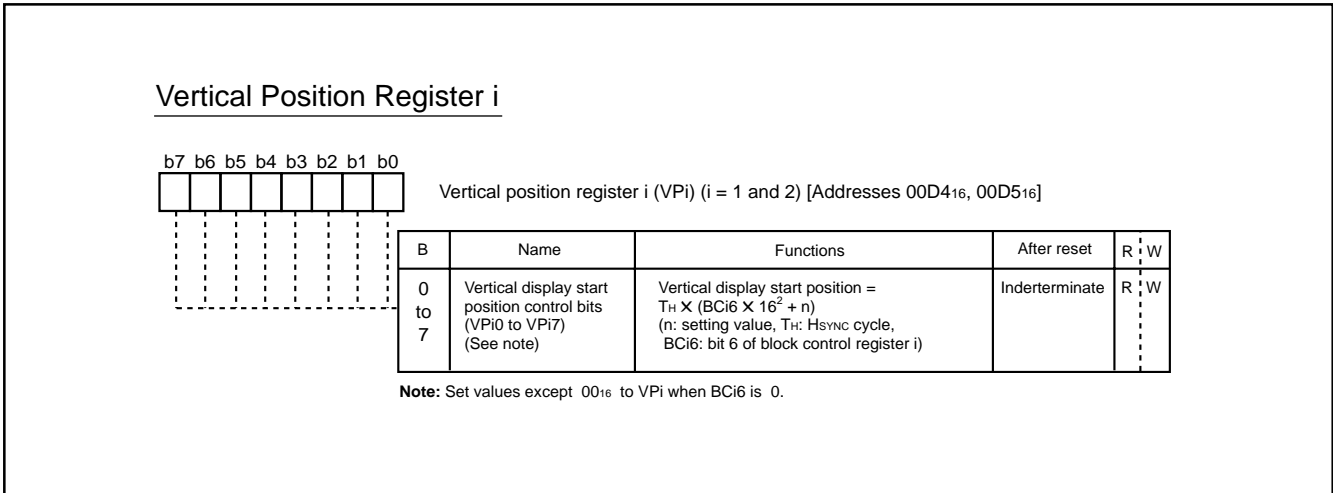

Fig. 8.11.7 Vertical Position Register i (i = 1 and 2)

M37272M6H/M8H/MAH/MFH-XXXSP/FP M37272E8SP/FP, M37272EFSP/FP

SINGLE-CHIP 8-BIT CMOS MICROCOMPUTER with CLOSED CAPTION DECODER
and ON-SCREEN DISPLAY CONTROLLER

The horizontal display start position is common to all blocks, and can be set in 128 steps (where 1 step is 4Tosc, TOSC being the OSD oscillation cycle) as values "0016" to "FF16" in bits 0 to 6 of the horizontal position register (address 00D116). The horizontal position register is shown in Figure 8.11.8.

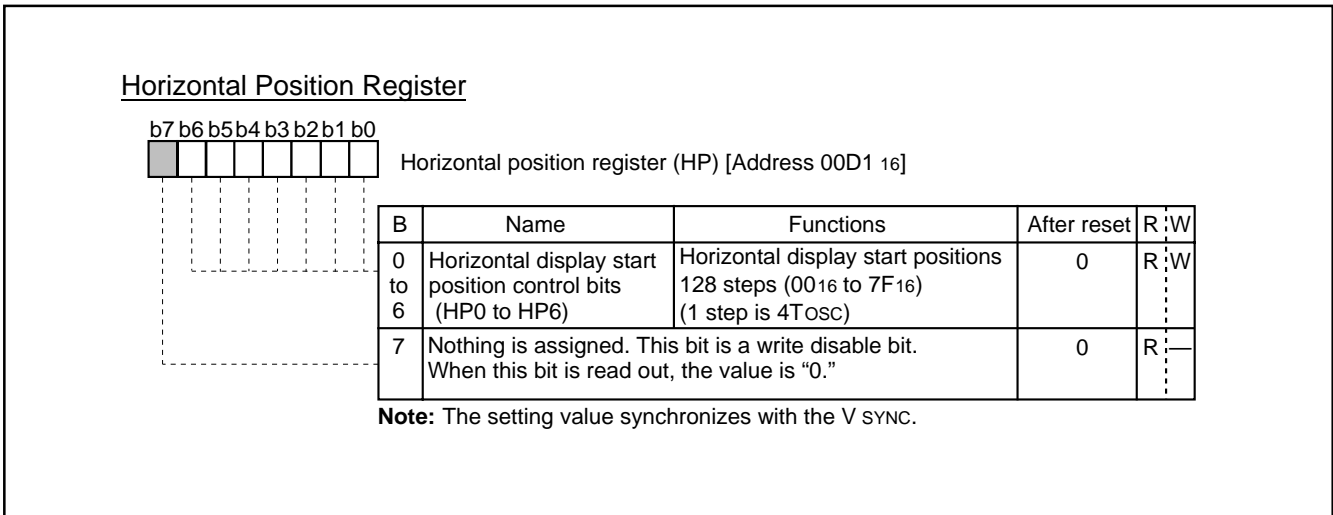

Fig. 8.11.8 Horizontal Position Register

- Notes 1 :** 1Tc (Tc : OSD clock cycle divided in pre-divide circuit) gap occurs between the horizontal display start position set by the horizontal position register and the most left dot of the 1st block. Accordingly, when 2 blocks have different pre-divide ratios, their horizontal display start position will not match.
- 2 :** The horizontal start position is based on the OSD clock source cycle selected for each block. Accordingly, when 2 blocks have different OSD clock source cycles, their horizontal display start position will not match.
- 3 :** When setting "0016" to the horizontal position register, it needs approximately 62Tosc (= Tdef) interval from a rising edge (when negative polarity is selected) of HSYNC signal to the horizontal display start position.

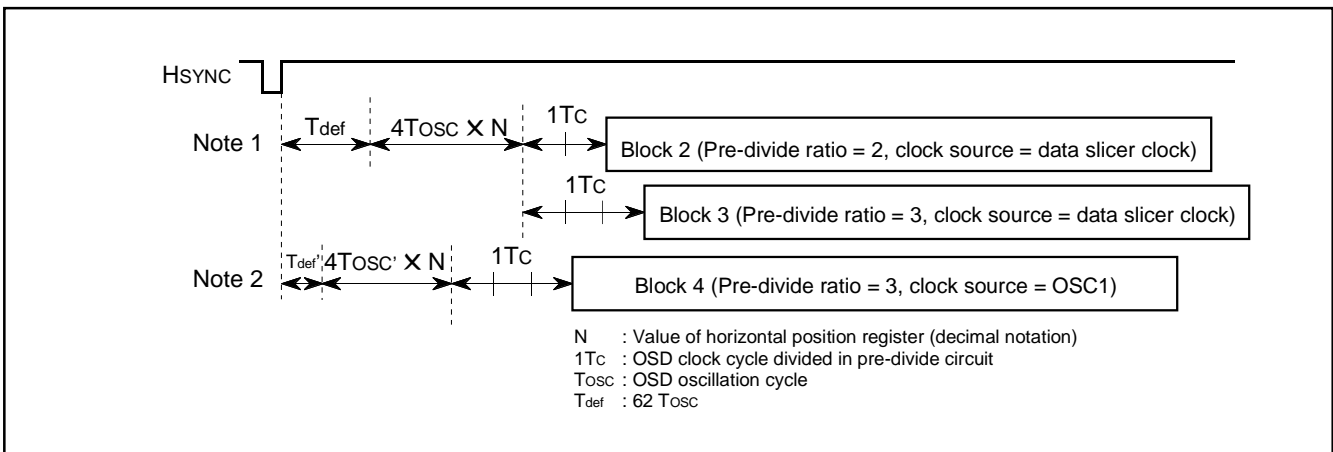

Fig. 8.11.9 Notes on Horizontal Display Start Position

M37272M6H/M8H/MAH/MFH-XXXSP/FP M37272E8SP/FP, M37272EFSP/FP

SINGLE-CHIP 8-BIT CMOS MICROCOMPUTER with CLOSED CAPTION DECODER
and ON-SCREEN DISPLAY CONTROLLER

8.11.2 Dot Size

The dot size can be selected by a block unit. The dot size in vertical direction is determined by dividing HSYNC in the vertical dot size control circuit. The dot size in horizontal is determined by dividing the following clock in the horizontal dot size control circuit : the clock gained by dividing the OSD clock source (data slicer clock, OSC1) in the pre-divide circuit. The clock cycle divided in the pre-divide circuit is defined as 1Tc.

The dot size of each block is specified by bits 2 to 4 of the block control register i.

Refer to Figure 8.11.4 (the structure of the block control register).

The block diagram of dot size control circuit is shown in Figure 8.11.10.

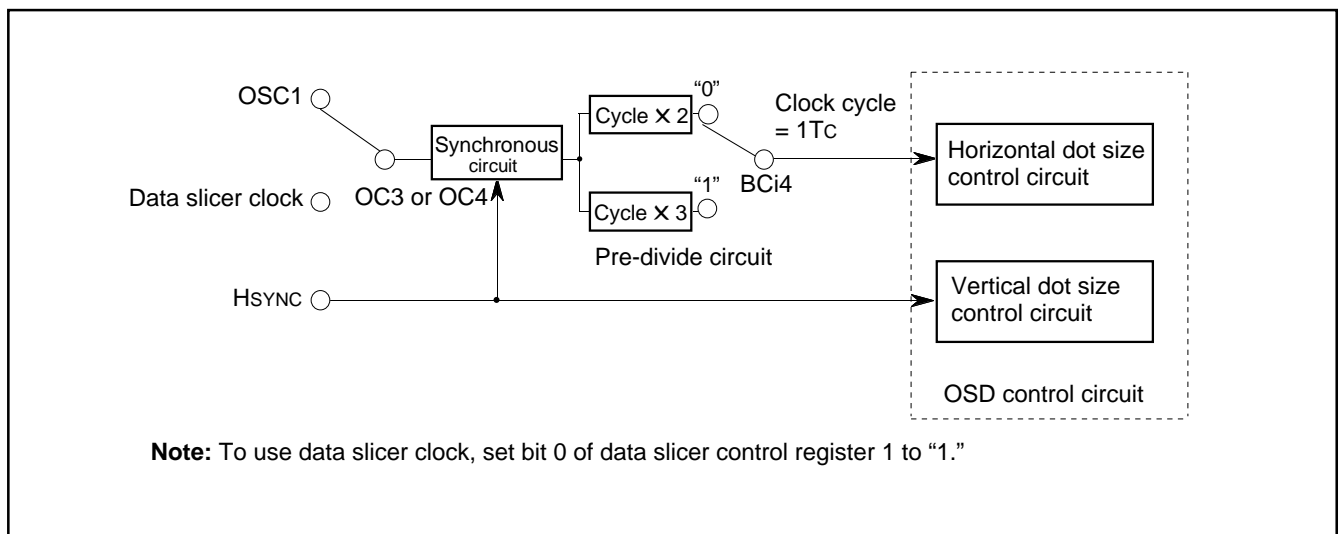

Fig. 8.11.10 Block Diagram of Dot Size Control Circuit

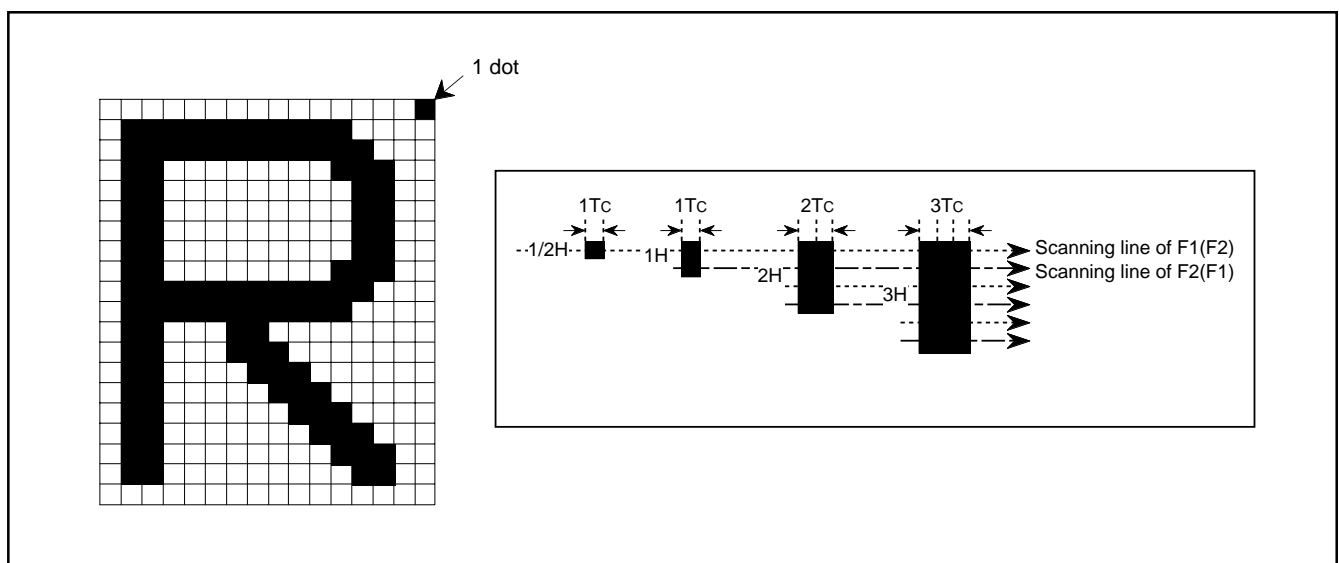

Fig. 8.11.11 Definition of Dot Sizes

M37272M6H/M8H/MAH/MFH-XXXSP/FP M37272E8SP/FP, M37272EFSP/FP

SINGLE-CHIP 8-BIT CMOS MICROCOMPUTER with CLOSED CAPTION DECODER
and ON-SCREEN DISPLAY CONTROLLER

8.11.3 Clock for OSD

As a clock for display to be used for OSD, it is possible to select one of the following 3 types.

- Data slicer clock output from the data slicer (approximately 26 MHz)
- OSC1 clock supplied from the pins OSC1 and OSC2
- Clock from the ceramic resonator or the LC oscillator from the pins OSC1 and OSC2

This OSD clock for each block can be selected by the following bits : bit 7 of the raster color register (address 00D9₁₆), bits 3 to 6 of the clock source control register (addresses 00D0₁₆). A variety of character sizes can be obtained by combining dot sizes with OSD clocks. When not using the pins OSC1 and OSC2 for the OSD clock I/O pins, the pins can be used as sub-clock I/O pins or port P2.

Table 8.11.2 Setting for P26/OSC1/XcIN, P27/OSC2/XcOUT

Register	Function	OSD clock I/O Pin	Sub-clock I/O Pin	I/O Port
b7 of raster color register		0	0	1
OSD control register	b6	1	0	1
	b5	0	0	0

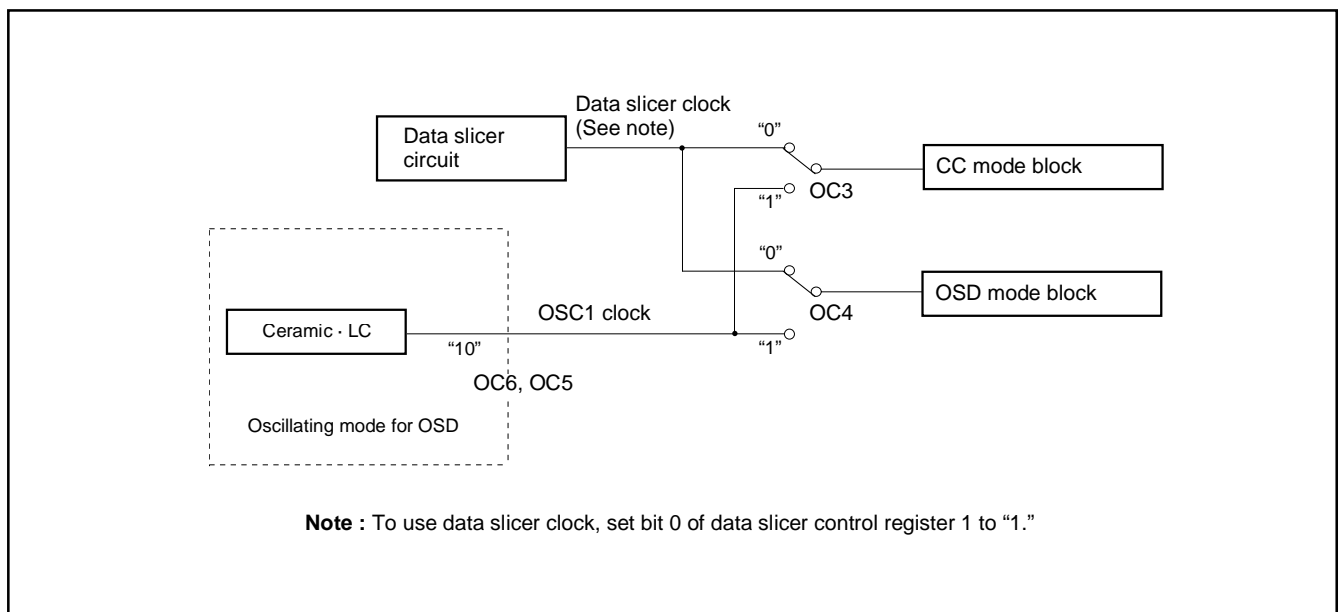

Fig. 8.11.12 Block Diagram of OSD Selection Circuit

M37272M6H/M8H/MAH/MFH-XXXSP/FP M37272E8SP/FP, M37272EFSP/FP

SINGLE-CHIP 8-BIT CMOS MICROCOMPUTER with CLOSED CAPTION DECODER
and ON-SCREEN DISPLAY CONTROLLER

8.11.4 Field Determination Display

To display the block with vertical dot size of 1/2H, whether an even field or an odd field is determined through differences in a synchronizing signal waveform of interlacing system. The dot line 0 or 1 (refer to Figure 8.11.14) corresponding to the field is displayed alternately.

In the following, the field determination standard for the case where both the horizontal sync signal and the vertical sync signal are negative-polarity inputs will be explained. A field determination is determined by detecting the time from a falling edge of the horizontal sync signal until a falling edge of the VSYNC control signal (refer to Figure 8.11.6) in the microcomputer and then comparing this time with the time of the previous field. When the time is longer than the comparing time, it is regarded as even field. When the time is shorter, it is regarded as odd field

The contents of this field can be read out by the field determination flag (bit 6 of the I/O polarity control register at address 00D8₁₆). A dot line is specified by bit 5 of the I/O polarity control register (refer to Figure 8.11.14).

However, the field determination flag read out from the CPU is fixed to "0" at even field or "1" at odd field, regardless of bit 5.

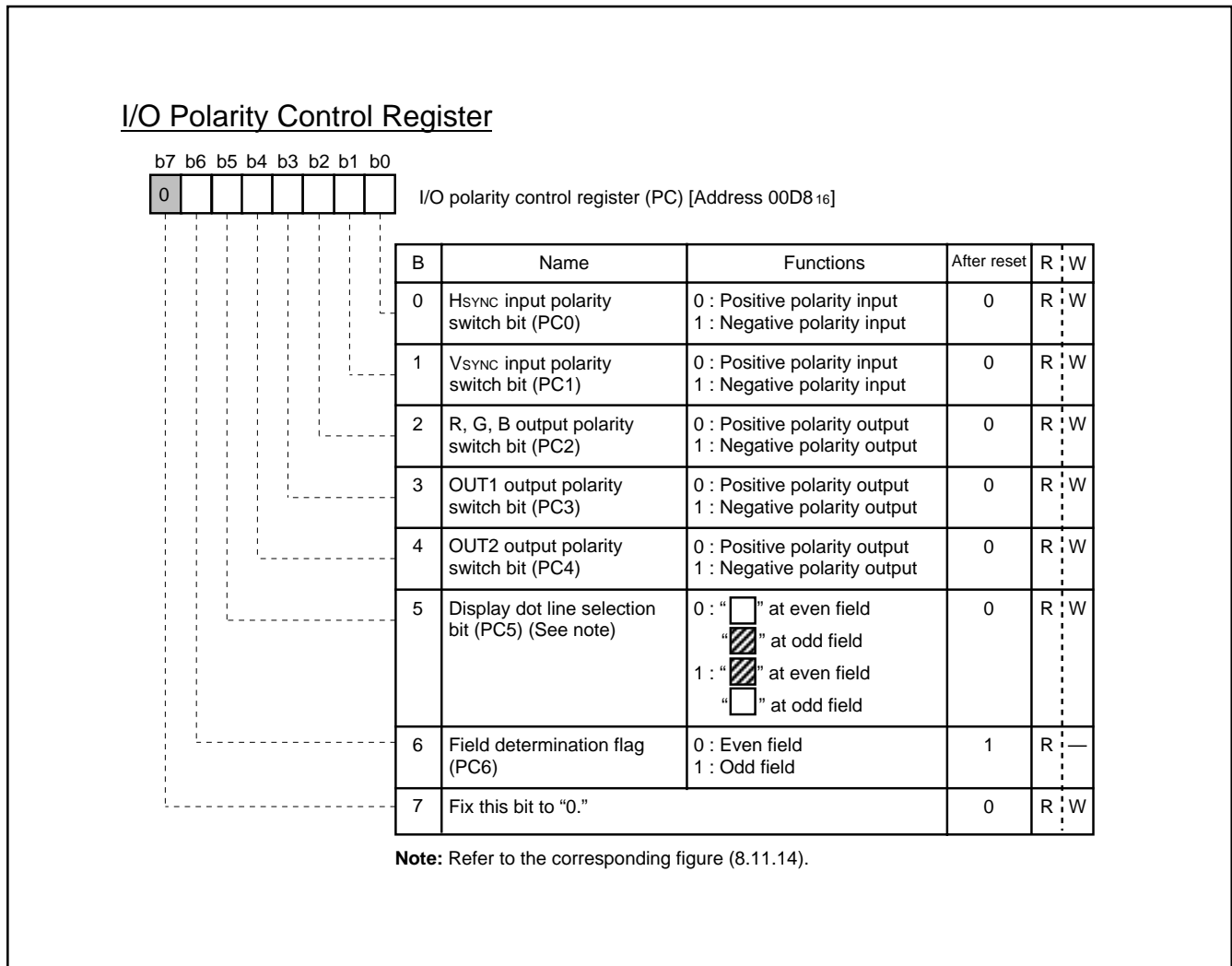

Fig. 8.11.13 I/O Polarity Control Register

M37272M6H/M8H/MAH/MFH-XXXSP/FP M37272E8SP/FP, M37272EFSP/FP

SINGLE-CHIP 8-BIT CMOS MICROCOMPUTER with CLOSED CAPTION DECODER
and ON-SCREEN DISPLAY CONTROLLER

Both HSYNC signal and VSYNC signal are negative-polarity input

Hsync		Field	Field determination flag(Note)	Display dot line selection bit	Display dot line
Vsync and Vsync control signal in microcomputer	 $0.25 \text{ to } 0.50[\mu\text{s}] \text{ at } f(X_{IN}) = 8 \text{ MHz}$	Odd			
Upper : Vsync signal	 $T2$	Even	0 ($T2 > T1$)	0	Dot line 1 <input type="checkbox"/>
Lower : Vsync control signal in microcomputer	 $T3$	Odd	1 ($T3 < T2$)	1	Dot line 0 <input checked="" type="checkbox"/>
				0	Dot line 0 <input checked="" type="checkbox"/>
				1	Dot line 1 <input type="checkbox"/>

When using the field determination flag, be sure to set bit 0 of the PWM mode register 1 (address 0208 16) to 0.

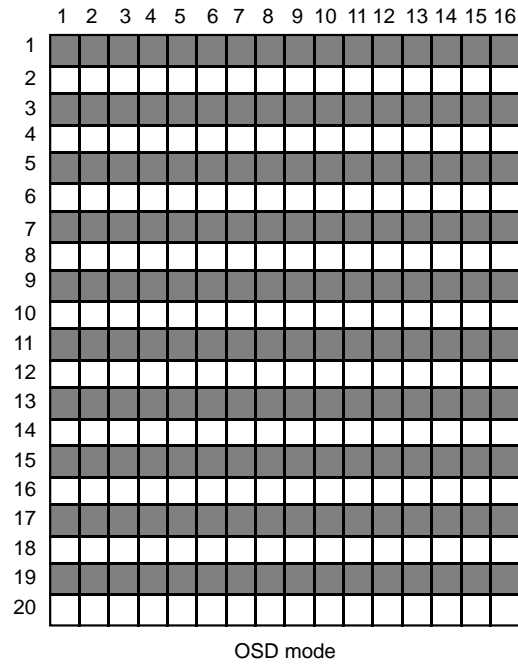
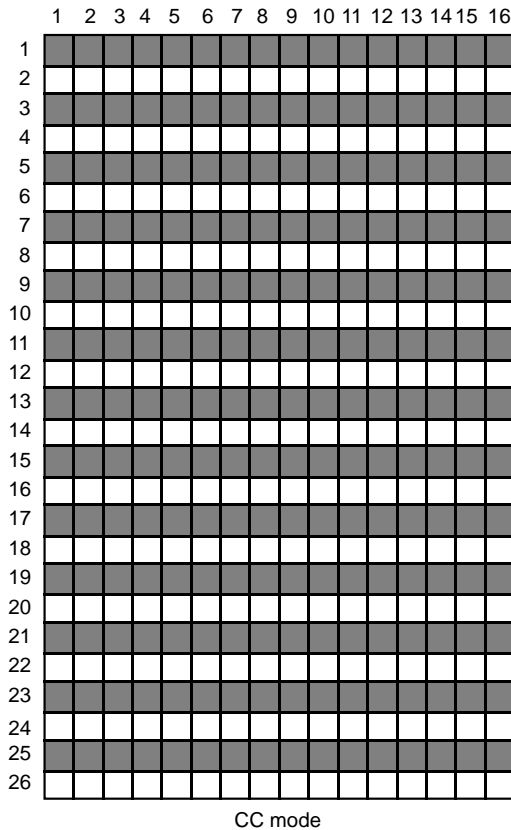

When the display dot line selection bit is 0, the font is displayed at even field, the font is displayed at odd field. Bit 6 of the I/O polarity control register can be read as the field determination flag : 1 is read at odd field, 0 is read at even field.

OSD ROM font configuration diagram

Note : The field determination flag changes at a rising edge of the V sync control signal (negative-polarity input) in the microcomputer.

Fig. 8.11.14 Relation between Field Determination Flag and Display Font

M37272M6H/M8H/MAH/MFH-XXXSP/FP M37272E8SP/FP, M37272EFSP/FP

SINGLE-CHIP 8-BIT CMOS MICROCOMPUTER with CLOSED CAPTION DECODER
and ON-SCREEN DISPLAY CONTROLLER

8.11.5 Memory for OSD

There are 2 types of memory for OSD : OSD ROM used to store character dot data and OSD RAM used to specify the characters and colors to be displayed.

<M37272M6H/M8H-XXXSP/FP, M37272E8SP/FP>

OSD ROM : addresses 1400₁₆ to 3BFF₁₆

OSD RAM : addresses 0800₁₆ to 087F₁₆

<M37272MAH/MFH-XXXSP/FP, M37272EFSP/FP>

OSD ROM : addresses 11400₁₆ to 13BFF₁₆

OSD RAM : addresses 0800₁₆ to 087F₁₆

(1) OSD ROM (addresses 1400₁₆ to 3BFF₁₆)

The dot pattern data for OSD characters is stored in OSD ROM. To specify the kinds of the character font, it is necessary to write the character code into the OSD RAM.

Data of the character font is specified shown in Figure 8.11.15.

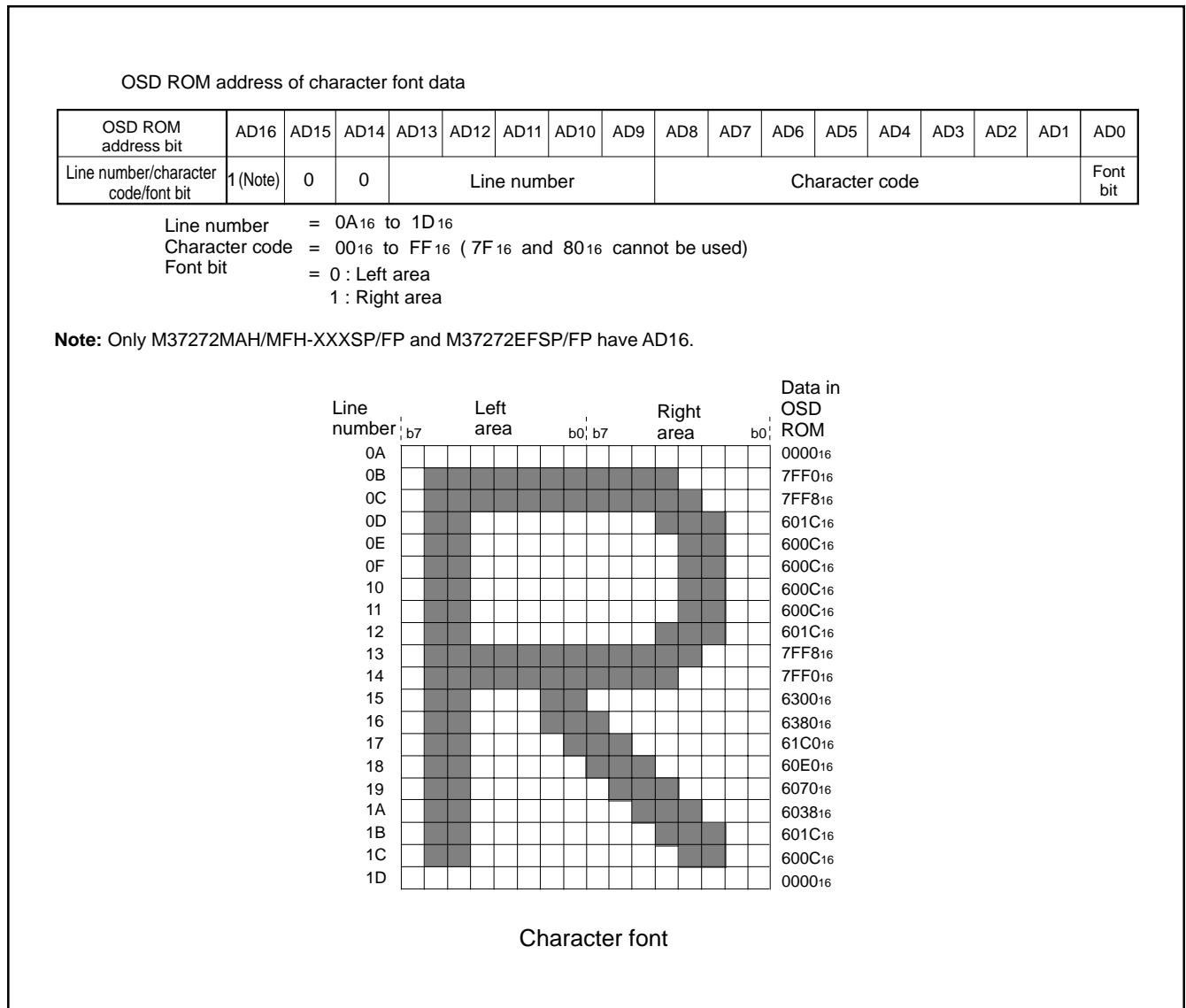

Fig. 8.11.15 Character Font Data Storing Address

M37272M6H/M8H/MAH/MFH-XXXSP/FP M37272E8SP/FP, M37272EFSP/FP

SINGLE-CHIP 8-BIT CMOS MICROCOMPUTER with CLOSED CAPTION DECODER
and ON-SCREEN DISPLAY CONTROLLER

Notes 1 : The 80-byte addresses corresponding to the character code "7F₁₆" and "80₁₆" in OSD ROM are the test data storing area. Set data to the area as follows.

<Test data storing area>

■ M37272M6H/M8H-XXXSP/FP, M37272E8SP/FP

addresses 1000₁₆ + (4 + 2n) X 100₁₆ + FE₁₆ to
1000₁₆ + (5 + 2n) X 100₁₆ + 01₁₆

(n = 0 to 19)

■ M37272MAH/MFH-XXXSP/FP, M37272EFSP/FP

addresses 11000₁₆ + (4 + 2n) X 100₁₆ + FE₁₆ to
11000₁₆ + (5 + 2n) X 100₁₆ + 01₁₆

(n = 0 to 19)

(1) Mask version (M37272M6H/M8H/MAH/MFH-XXXSP/FP)

Set "FF₁₆" to the area (We stores the test data to this area and the different data from "FF₁₆" is stored for the actual products.) When using our font editor, the test data is written automatically.

(2) EPROM version (M37272E8SP/FP, M37272EFSP/FP)

Set the test data to the area. When using our font editor, the test data is written automatically.

■ M37272E8SP/FP

<"FF₁₆"> address (test data)

14FE₁₆ (09₁₆), 14FF₁₆ (51₁₆)
16FE₁₆ (00₁₆), 16FF₁₆ (52₁₆)
18FE₁₆ (12₁₆), 18FF₁₆ (53₁₆)
1AFE₁₆ (00₁₆), 1AFF₁₆ (54₁₆)
1CFE₁₆ (24₁₆), 1CFF₁₆ (55₁₆)
1EFE₁₆ (00₁₆), 1EFF₁₆ (56₁₆)
20FE₁₆ (88₁₆), 20FF₁₆ (57₁₆)
22FE₁₆ (00₁₆), 22FF₁₆ (58₁₆)
24FE₁₆ (90₁₆), 24FF₁₆ (59₁₆)
26FE₁₆ (48₁₆), 26FF₁₆ (5A₁₆)
28FE₁₆ (24₁₆), 28FF₁₆ (5B₁₆)
2AFE₁₆ (00₁₆), 2AFF₁₆ (5C₁₆)
2CFE₁₆ (24₁₆), 2CFF₁₆ (5D₁₆)
2EFE₁₆ (48₁₆), 2EFF₁₆ (5E₁₆)
30FE₁₆ (00₁₆), 30FF₁₆ (5F₁₆)
32FE₁₆ (48₁₆), 32FF₁₆ (50₁₆)
34FE₁₆ (90₁₆), 34FF₁₆ (51₁₆)
36FE₁₆ (00₁₆), 36FF₁₆ (52₁₆)
38FE₁₆ (01₁₆), 38FF₁₆ (53₁₆)
3AFE₁₆ (80₁₆), 3AFF₁₆ (54₁₆)

<"80₁₆"> address (test data)

1500₁₆ (90₁₆), 1501₁₆ (A1₁₆)
1700₁₆ (00₁₆), 1701₁₆ (A2₁₆)
1900₁₆ (48₁₆), 1901₁₆ (A3₁₆)
1B00₁₆ (00₁₆), 1B01₁₆ (A4₁₆)
1D00₁₆ (24₁₆), 1D01₁₆ (A5₁₆)
1F00₁₆ (00₁₆), 1F01₁₆ (A6₁₆)
2100₁₆ (12₁₆), 2101₁₆ (A7₁₆)
2300₁₆ (00₁₆), 2301₁₆ (A8₁₆)
2500₁₆ (09₁₆), 2501₁₆ (A9₁₆)
2700₁₆ (00₁₆), 2701₁₆ (AA₁₆)
2900₁₆ (81₁₆), 2901₁₆ (AB₁₆)
2B00₁₆ (18₁₆), 2B01₁₆ (AC₁₆)
2D00₁₆ (00₁₆), 2D01₁₆ (AD₁₆)
2F00₁₆ (42₁₆), 2F01₁₆ (AE₁₆)
3100₁₆ (24₁₆), 3101₁₆ (AF₁₆)
3300₁₆ (00₁₆), 3301₁₆ (B0₁₆)
3500₁₆ (81₁₆), 3501₁₆ (B1₁₆)
3700₁₆ (0C₁₆), 3701₁₆ (B2₁₆)
3900₁₆ (06₁₆), 3901₁₆ (B3₁₆)
3B00₁₆ (00₁₆), 3B01₁₆ (B4₁₆)

■ M37272EFSP/FP

<"7F₁₆"> address (test data)

114FE₁₆ (09₁₆), 114FF₁₆ (51₁₆)
116FE₁₆ (00₁₆), 116FF₁₆ (52₁₆)
118FE₁₆ (12₁₆), 118FF₁₆ (53₁₆)
11AFE₁₆ (00₁₆), 11AFF₁₆ (54₁₆)
11CFE₁₆ (24₁₆), 11CFF₁₆ (55₁₆)
11EFE₁₆ (00₁₆), 11EFF₁₆ (56₁₆)
120FE₁₆ (88₁₆), 120FF₁₆ (57₁₆)
122FE₁₆ (00₁₆), 122FF₁₆ (58₁₆)
124FE₁₆ (90₁₆), 124FF₁₆ (59₁₆)
126FE₁₆ (48₁₆), 126FF₁₆ (5A₁₆)
128FE₁₆ (24₁₆), 128FF₁₆ (5B₁₆)
12AFE₁₆ (00₁₆), 12AFF₁₆ (5C₁₆)
12CFE₁₆ (24₁₆), 12CFF₁₆ (5D₁₆)
12EFE₁₆ (48₁₆), 12EFF₁₆ (5E₁₆)
12F00₁₆ (42₁₆), 12F01₁₆ (AE₁₆)
130FE₁₆ (00₁₆), 130FF₁₆ (5F₁₆)
132FE₁₆ (48₁₆), 132FF₁₆ (50₁₆)
134FE₁₆ (90₁₆), 134FF₁₆ (51₁₆)
136FE₁₆ (00₁₆), 136FF₁₆ (52₁₆)
138FE₁₆ (01₁₆), 138FF₁₆ (53₁₆)
13AFE₁₆ (80₁₆), 13AFF₁₆ (54₁₆)

<"80₁₆"> address (test data)

11500₁₆ (90₁₆), 11501₁₆ (A1₁₆)
11700₁₆ (00₁₆), 11701₁₆ (A2₁₆)
11900₁₆ (48₁₆), 11901₁₆ (A3₁₆)
11B00₁₆ (00₁₆), 11B01₁₆ (A4₁₆)
11D00₁₆ (24₁₆), 11D01₁₆ (A5₁₆)
11F00₁₆ (00₁₆), 11F01₁₆ (A6₁₆)
12100₁₆ (12₁₆), 12101₁₆ (A7₁₆)
12300₁₆ (00₁₆), 12301₁₆ (A8₁₆)
12500₁₆ (09₁₆), 12501₁₆ (A9₁₆)
12700₁₆ (00₁₆), 12701₁₆ (AA₁₆)
12900₁₆ (81₁₆), 12901₁₆ (AB₁₆)
12B00₁₆ (18₁₆), 12B01₁₆ (AC₁₆)
12D00₁₆ (00₁₆), 12D01₁₆ (AD₁₆)
12F00₁₆ (42₁₆), 12F01₁₆ (AE₁₆)
13100₁₆ (24₁₆), 13101₁₆ (AF₁₆)
13300₁₆ (00₁₆), 13301₁₆ (B0₁₆)
13500₁₆ (81₁₆), 13501₁₆ (B1₁₆)
13700₁₆ (0C₁₆), 13701₁₆ (B2₁₆)
13900₁₆ (06₁₆), 13901₁₆ (B3₁₆)
13B00₁₆ (00₁₆), 13B01₁₆ (B4₁₆)

2 : The character code "09₁₆" is used for "transparent space" when displaying Closed Caption.

Therefore, set "00₁₆" to the 40-byte addresses corresponding to the character code "09₁₆."

<Transparent space font data storing area>

■ M37272M6H/M8H-XXXSP/FP, M37272E8SP/FP

addresses 1000₁₆ + (4 + 2n) X 100₁₆ + 12₁₆ to
1000₁₆ + (4 + 2n) X 100₁₆ + 13₁₆

(n = 0 to 19)

addresses 1412 ₁₆ and 1413 ₁₆
addresses 1612 ₁₆ and 1613 ₁₆
⋮
addresses 3812 ₁₆ and 3813 ₁₆
addresses 3A12 ₁₆ and 3A13 ₁₆

■ M37272MAH/MFH-XXXSP/FP, M37272EFSP/FP

addresses 11000₁₆ + (4 + 2n) X 100₁₆ + 12₁₆ to
11000₁₆ + (4 + 2n) X 100₁₆ + 13₁₆

(n = 0 to 19)

addresses 11412 ₁₆ and 11413 ₁₆
addresses 11612 ₁₆ and 11613 ₁₆
⋮
addresses 13812 ₁₆ and 13813 ₁₆
addresses 13A12 ₁₆ and 13A13 ₁₆

M37272M6H/M8H/MAH/MFH-XXXSP/FP
M37272E8SP/FP, M37272EFSP/FP

SINGLE-CHIP 8-BIT CMOS MICROCOMPUTER with CLOSED CAPTION DECODER
 and ON-SCREEN DISPLAY CONTROLLER

(2) OSD RAM

The RAM for OSD is allocated at addresses 0800₁₆ to 087F₁₆, and is divided into a display character code specification part, color code 1 specification part, and color code 2 specification part for each block. Table 8.11.3 shows the contents of the OSD RAM.

For example, to display 1 character position (the left edge) in block 1, write the character code in address 0800₁₆, write the color code 1 at 0820₁₆.

The structure of the OSD RAM is shown in Figure 8.11.16.

Table 8.11.3 Contents of OSD RAM

Block	Display Position (from left)	Character Code Specification	Color Code Specification
Block 1	1st character	0800 ₁₆	0820 ₁₆
	2nd character	0801 ₁₆	0821 ₁₆
	3rd character	0802 ₁₆	0822 ₁₆
	⋮	⋮	⋮
	30th character	081D ₁₆	083D ₁₆
	31st character	081E ₁₆	083E ₁₆
Block 2	32nd character	081F ₁₆	083F ₁₆
	1st character	0840 ₁₆	0860 ₁₆
	2nd character	0841 ₁₆	0861 ₁₆
	3rd character	0842 ₁₆	0862 ₁₆
	⋮	⋮	⋮
	30th character	085D ₁₆	087D ₁₆
	31st character	085E ₁₆	087E ₁₆
32nd character	085F ₁₆	087F ₁₆	

M37272M6H/M8H/MAH/MFH-XXXSP/FP M37272E8SP/FP, M37272EFSP/FP

SINGLE-CHIP 8-BIT CMOS MICROCOMPUTER with CLOSED CAPTION DECODER
and ON-SCREEN DISPLAY CONTROLLER

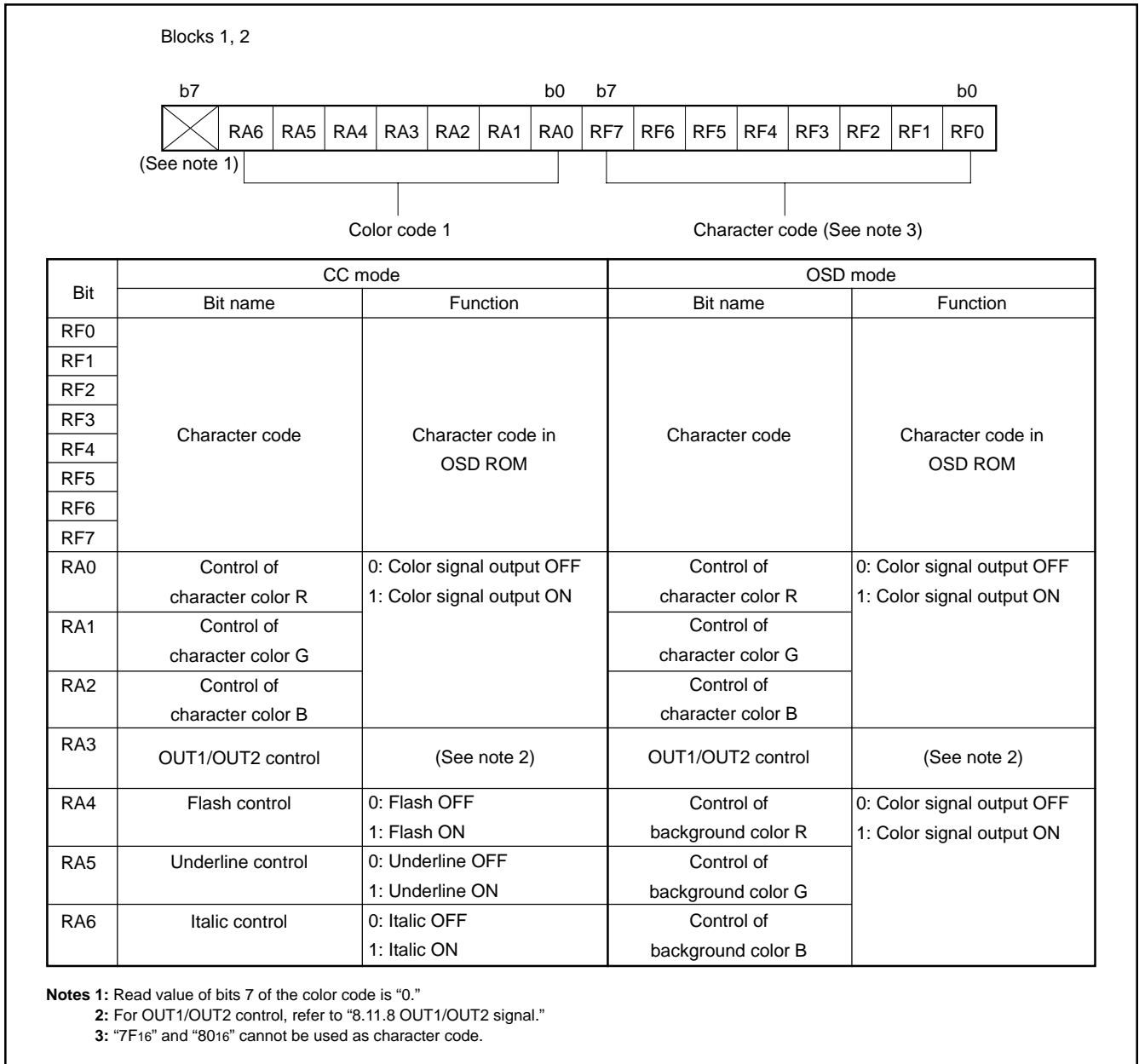

Fig. 8.11.16 Bit structure of OSD RAM

**M37272M6H/M8H/MAH/MFH-XXXSP/FP
M37272E8SP/FP, M37272EFSP/FP**

SINGLE-CHIP 8-BIT CMOS MICROCOMPUTER with CLOSED CAPTION DECODER
and ON-SCREEN DISPLAY CONTROLLER

8.11.6 Character color

The color for each character is displayed by the color code.
<7 kinds>
Specified by bits 0 (R), 1 (G), and 2 (B) of the color code

8.11.7 Character background color

The character background color can be displayed in the character display area only in the OSD mode. The character background color for each character is specified by the color code.
<7 kinds>
Specified by bits 4 (R), 5 (G), and 6 (B) of the color code

Note : The character background color is displayed in the following part :
(character display area)-(character font)-(border).
Accordingly, the character background color does not mix with these color signal.

M37272M6H/M8H/MAH/MFH-XXXSP/FP M37272E8SP/FP, M37272EFSP/FP

SINGLE-CHIP 8-BIT CMOS MICROCOMPUTER with CLOSED CAPTION DECODER
and ON-SCREEN DISPLAY CONTROLLER

8.11.8 OUT1, OUT2 signals

The OUT1, OUT2 signals are used to control the luminance of the video signal. The output waveform of the OUT1, OUT2 signals is controlled by display mode, bit 5 of the block control register *i* (refer to Figure 8.11.4) and RA3 of OSD RAM. The setting values for

controlling OUT1, OUT2 and the corresponding output waveform is shown in Figure 8.11.17.

Note : When OUT2 signal is output, set bit 7 of OSD port control register (refer to Figure 8.11.28) to "1."

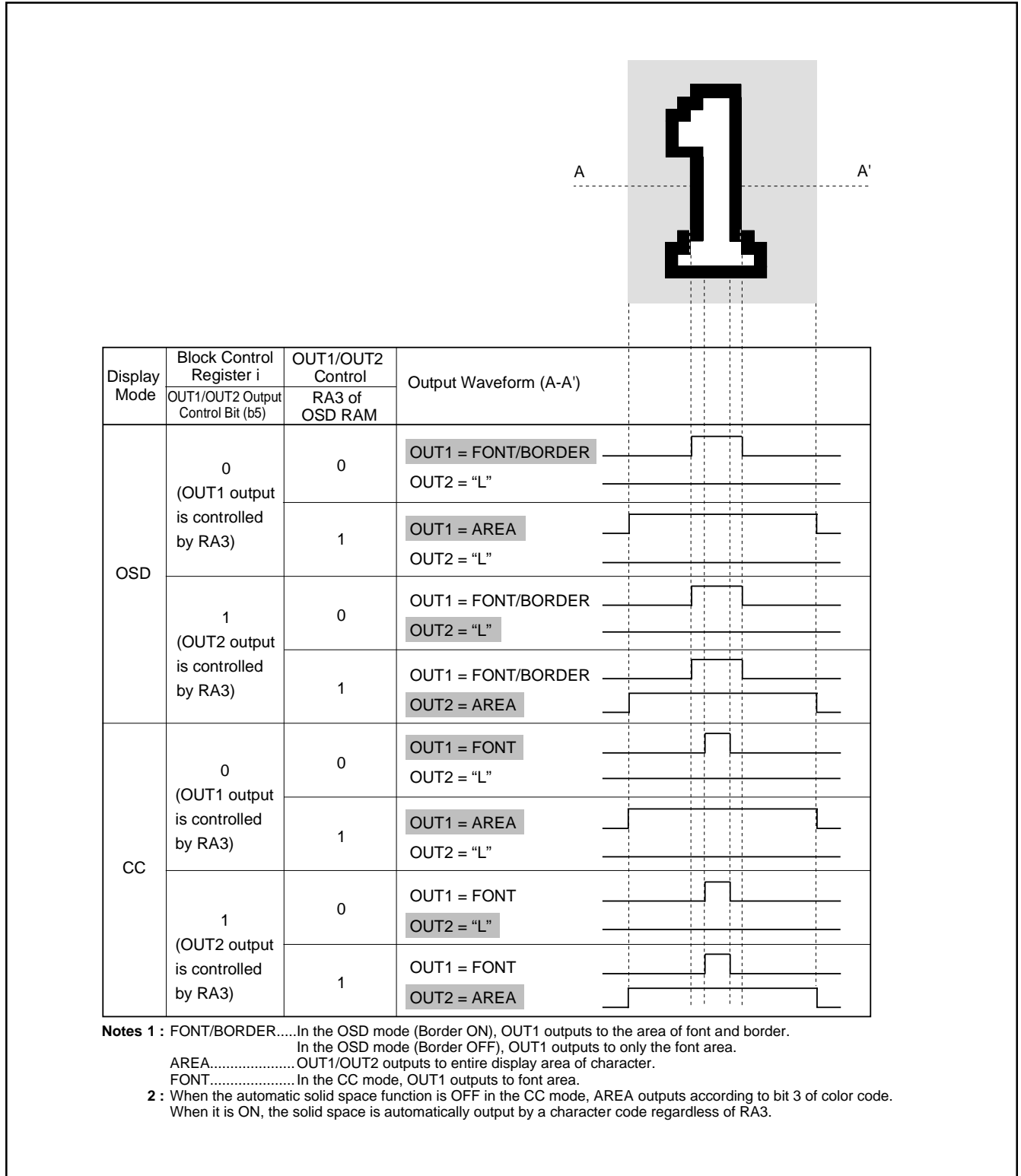

Fig. 8.11.17 Setting Value for Controlling OUT1, OUT2 and Corresponding Output Waveform

**M37272M6H/M8H/MAH/MFH-XXXSP/FP
M37272E8SP/FP, M37272EFSP/FP**

SINGLE-CHIP 8-BIT CMOS MICROCOMPUTER with CLOSED CAPTION DECODER
and ON-SCREEN DISPLAY CONTROLLER

8.11.9 Attribute

The attributes (border, flash, underline, italic) are controlled to the character font. The attributes to be controlled are different depending on each mode.

CC mode Flash, underline, italic (per character unit)
OSD mode Border (per character unit)

(1) Under line

The underline is output at the 23th and 24th dots in vertical direction only in the CC mode. The underline is controlled by RA5 of OSD RAM. The color of underline is the same color as that of the character font.

(2) Flash

The character font and the underline are flashed only in the CC mode. The flash is controlled by RA4 of OSD RAM. As for character font part, the character output part is flashed, the character background part is not flashed. The flash cycle bases on the VSYNC count.

- VSYNC cycle X 48 ≈ 800 ms (at display ON)
- VSYNC cycle X 16 ≈ 267 ms (at display OFF)

(3) Italic

The italic is made by slanting the font stored in OSD ROM to the right only in the CC mode. The italic is controlled by RA6 of OSD RAM.

The display example of the italic and underline is shown in Figure 8.11.8. In this case, "R" is displayed.

- Notes**
- 1: When setting both the italic and the flash, the italic character flashes.
 - 2: The boundary of character color is displayed in italic. However, the boundary of character background color is not affected by the italic (refer to Figure 8.11.19).
 - 3: The adjacent character (one side or both side) to an italic character is displayed in italic even when the character is not specified to display in italic (refer to Figure 8.11.19).

M37272M6H/M8H/MAH/MFH-XXXSP/FP M37272E8SP/FP, M37272EFSP/FP

SINGLE-CHIP 8-BIT CMOS MICROCOMPUTER with CLOSED CAPTION DECODER
and ON-SCREEN DISPLAY CONTROLLER

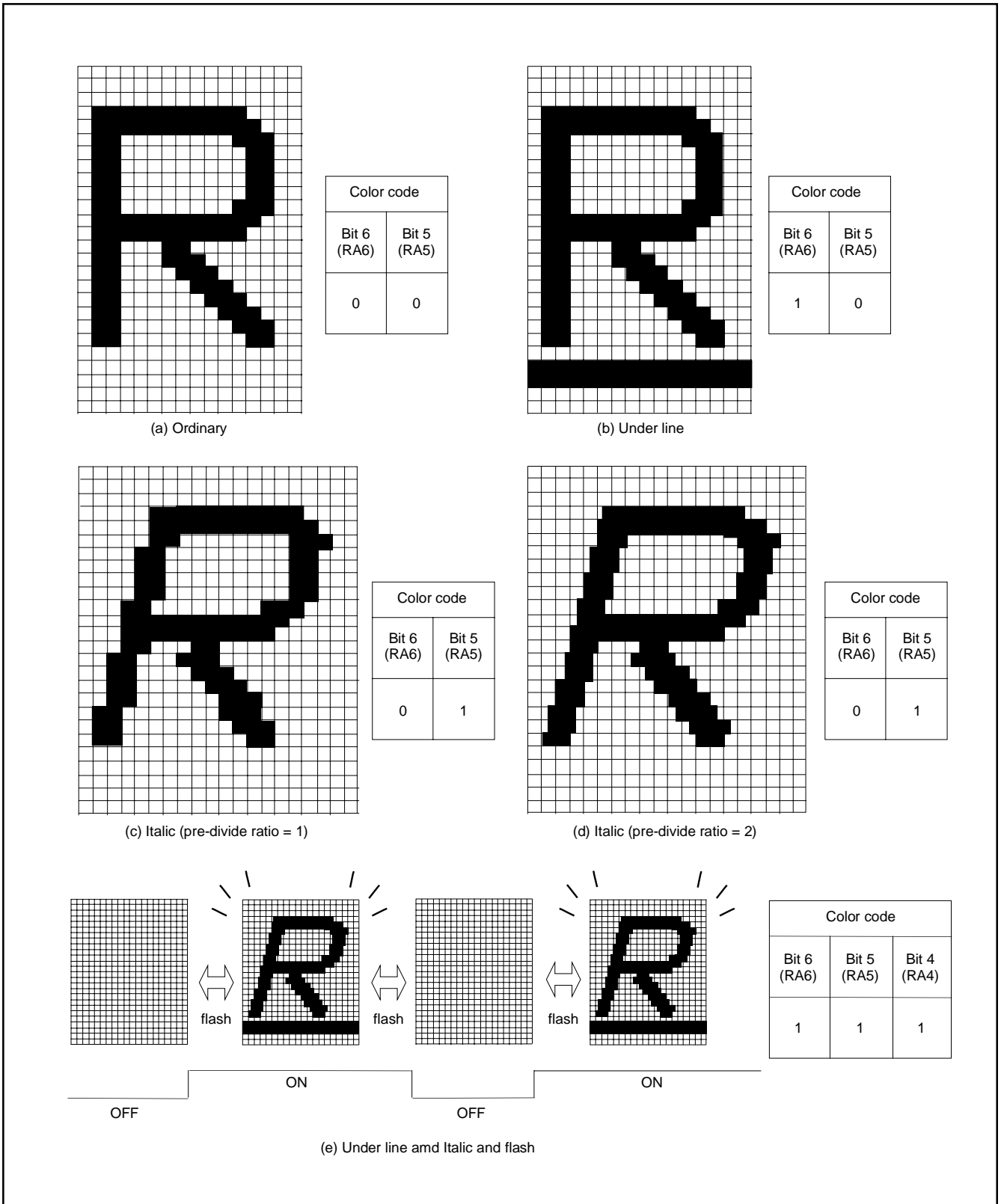

Fig. 8.11.18 Example of Attribute Display (in CC Mode)

M37272M6H/M8H/MAH/MFH-XXXSP/FP
M37272E8SP/FP, M37272EFSP/FP

SINGLE-CHIP 8-BIT CMOS MICROCOMPUTER with CLOSED CAPTION DECODER
 and ON-SCREEN DISPLAY CONTROLLER

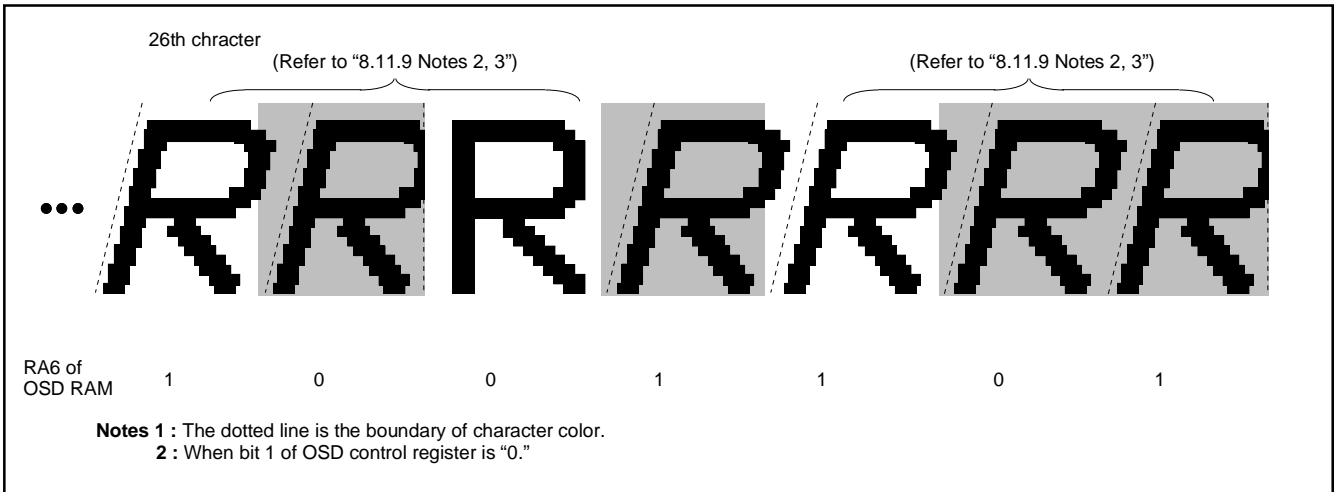

Fig. 8.11.19 Example of Italic Display

M37272M6H/M8H/MAH/MFH-XXXSP/FP M37272E8SP/FP, M37272EFSP/FP

SINGLE-CHIP 8-BIT CMOS MICROCOMPUTER with CLOSED CAPTION DECODER
and ON-SCREEN DISPLAY CONTROLLER

(4) Border

The border is output around of character font (all bordered) in the OSD mode. The border ON/OFF is controlled by bit 0 and 1 of the block control register i (refer to Figure 8.11.4).

The OUT1 signal is used for border output.

The horizontal size (x) of border is 1Tc (OSD clock cycle divided in pre-divide circuit) regardless of the character font dot size. The vertical size (y) different depending on the screen scan mode and the vertical dot size of character font.

- Notes 1 : The border dot area is the shaded area as shown in Figure 8.11.20.
- 2 : When the border dot overlaps on the next character font, the character font has priority (refer to Figure 8.11.22 A).
When the border dot overlaps on the next character back ground, the border has priority (refer to Figure 8.11.22 B).
- 3 : The border in vertical out of character area is not displayed (refer to Figure 8.11.22).

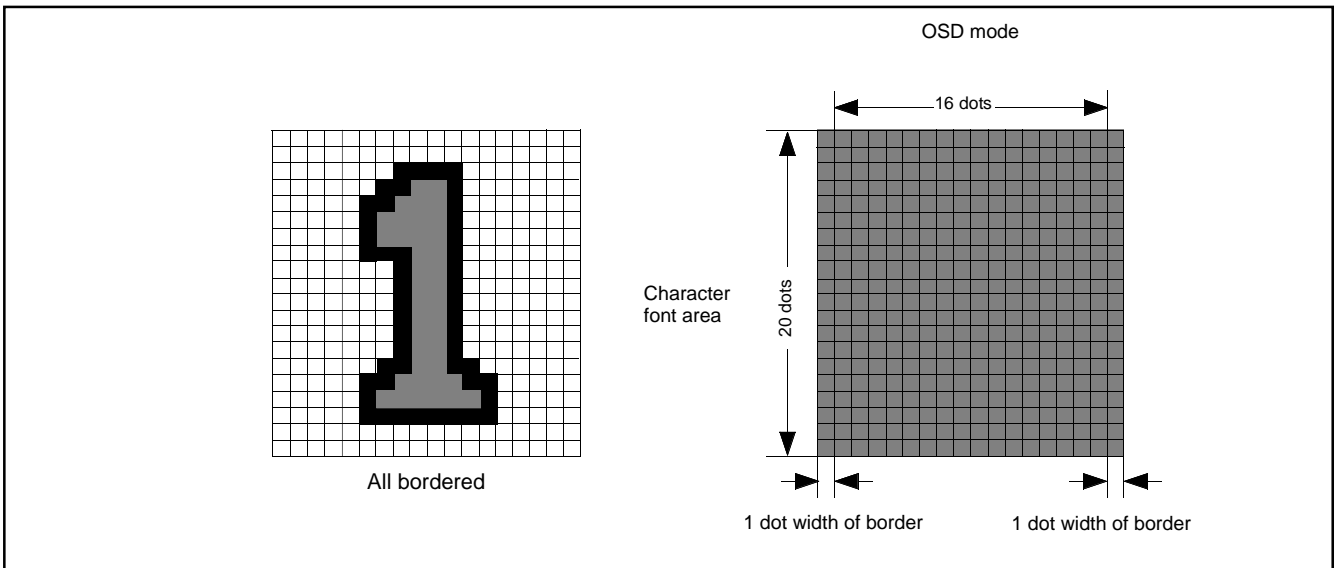

Fig. 8.11.20 Example of Border Display

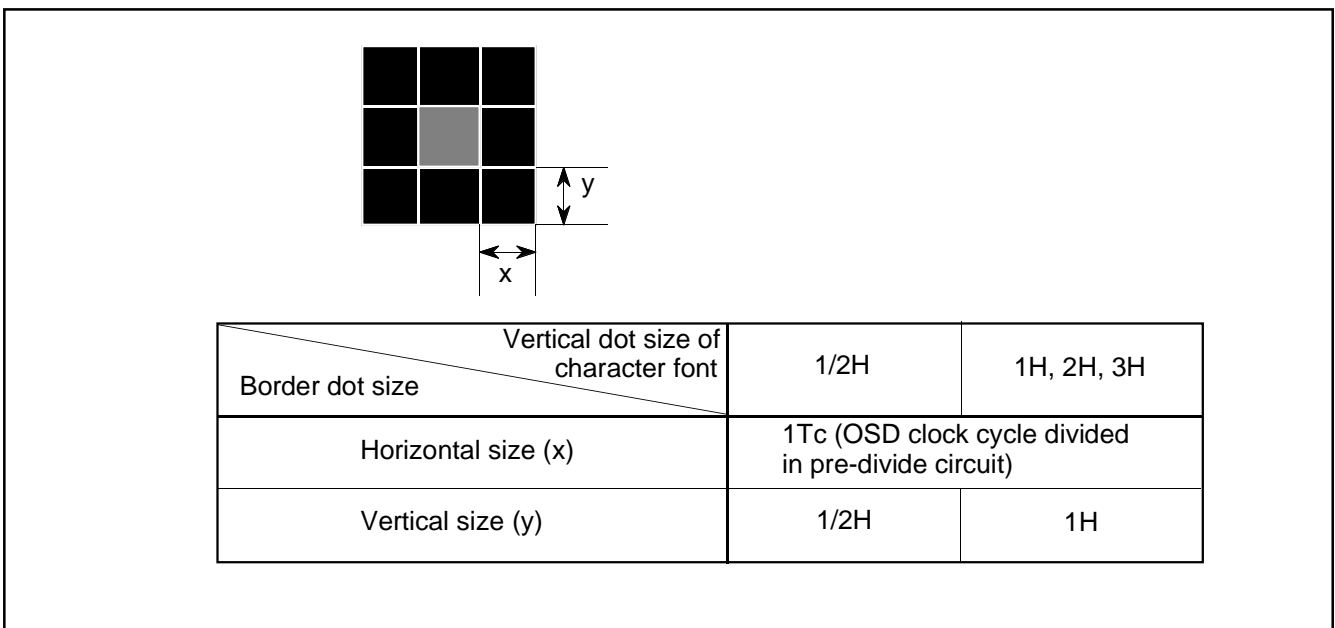

Fig. 8.11.21 Horizontal and Vertical Size of Border

M37272M6H/M8H/MAH/MFH-XXXSP/FP M37272E8SP/FP, M37272EFSP/FP

SINGLE-CHIP 8-BIT CMOS MICROCOMPUTER with CLOSED CAPTION DECODER
and ON-SCREEN DISPLAY CONTROLLER

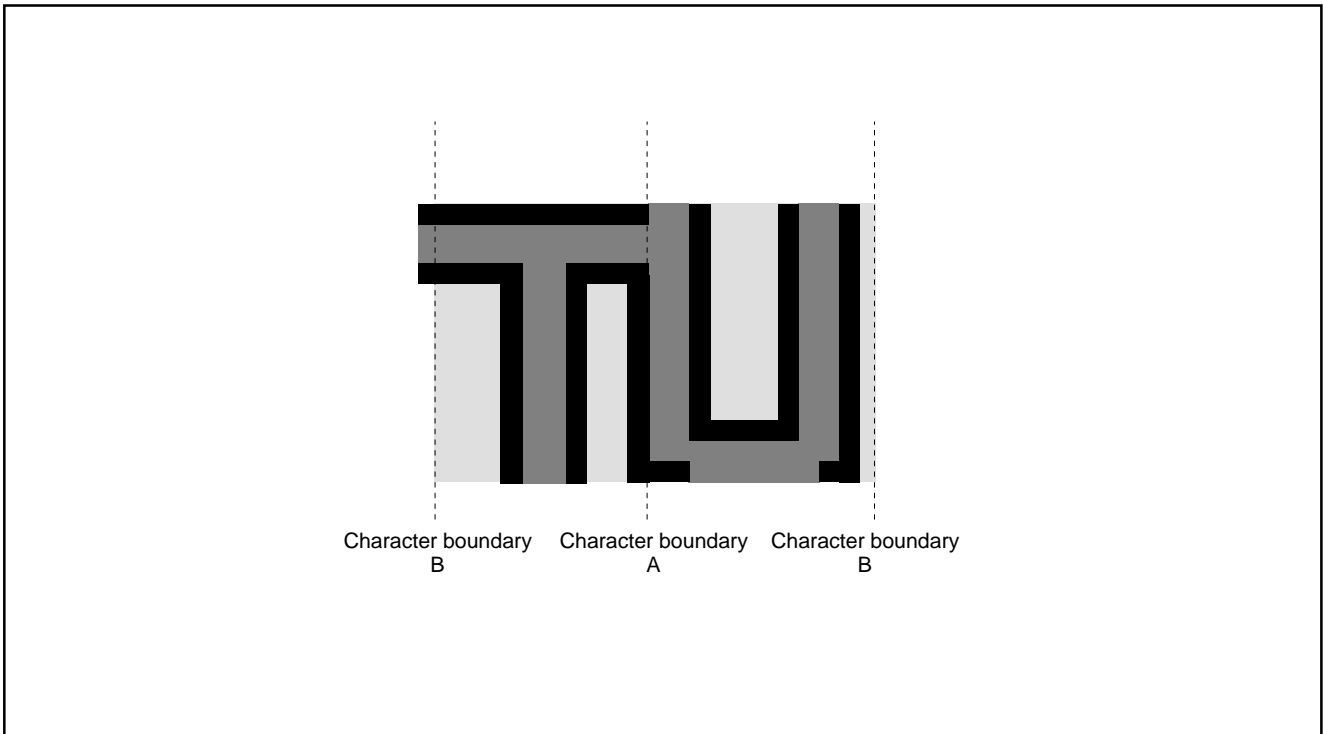

Fig. 8.11.22 Border Priority

M37272M6H/M8H/MAH/MFH-XXXSP/FP M37272E8SP/FP, M37272EFSP/FP

SINGLE-CHIP 8-BIT CMOS MICROCOMPUTER with CLOSED CAPTION DECODER
and ON-SCREEN DISPLAY CONTROLLER

8.11.10 Multiline Display

This microcomputer can ordinarily display 2 lines on the CRT screen by displaying 2 blocks at different vertical positions. In addition, it can display up to 16 lines by using OSD interrupts.

An OSD interrupt request occurs at the point at which display of each block has been completed. In other words, when a scanning line reaches the point of the display position (specified by the vertical position registers) of a certain block, the character display of that block starts, and an interrupt occurs at the point at which the scanning line exceeds the block.

- Notes 1:** An OSD interrupt does not occur at the end of display when the block is not displayed. In other words, if a block is set to off display by the display control bit of the block control register (addresses 00D216, 00D316), an OSD interrupt request does not occur (refer to Figure 8.11.23 (A)).
- 2:** When another block display appears while one block is displayed, an OSD interrupt request occurs only once at the end of the another block display (refer to Figure 8.11.23 (B)).
- 3:** On the screen setting window, an OSD interrupt occurs even at the end of the CC mode block (off display) out of window (refer to Figure 8.11.23 (C)).

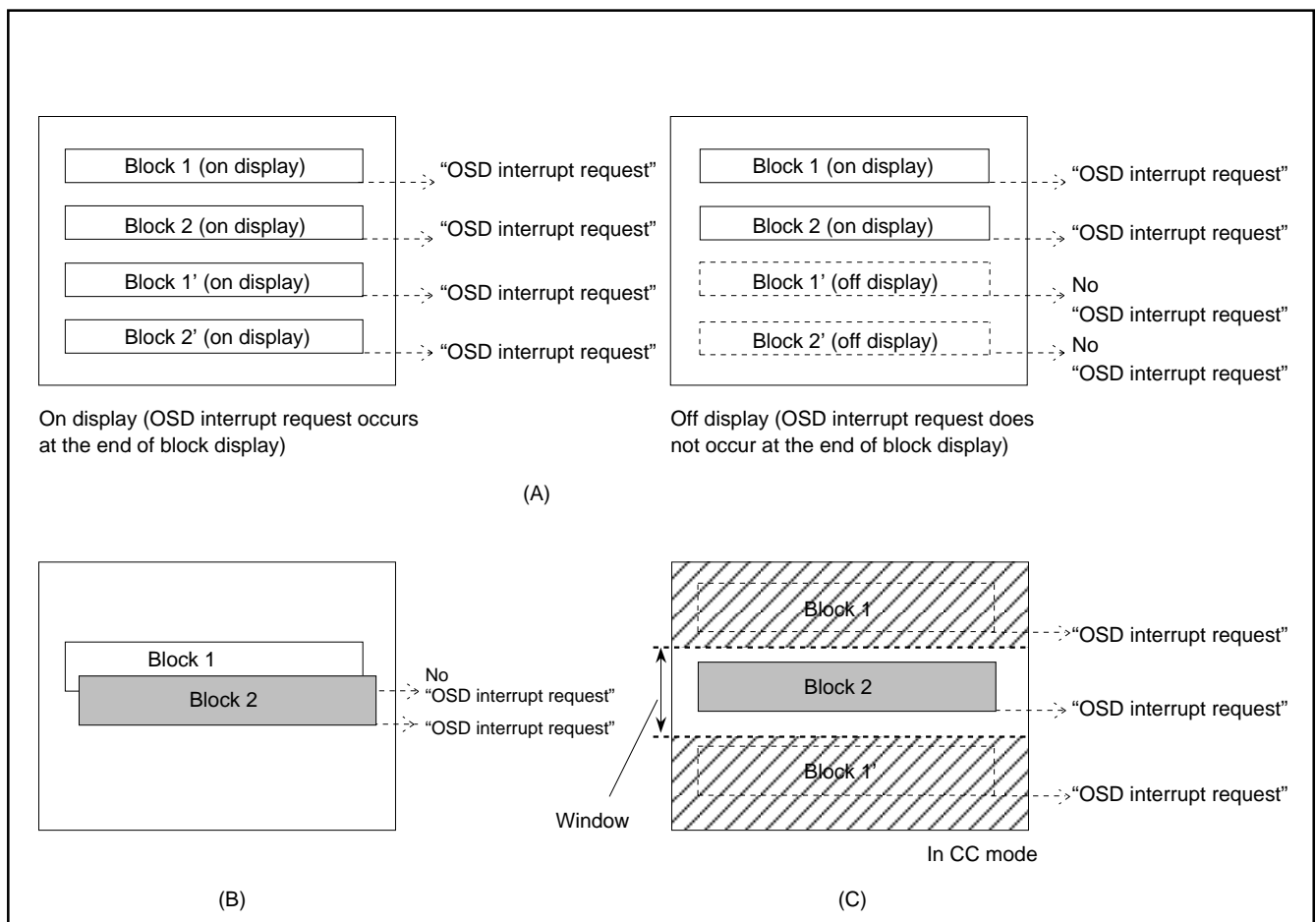

Fig. 8.11.23 Note on Occurrence of OSD Interrupt

M37272M6H/M8H/MAH/MFH-XXXSP/FP M37272E8SP/FP, M37272EFSP/FP

SINGLE-CHIP 8-BIT CMOS MICROCOMPUTER with CLOSED CAPTION DECODER
and ON-SCREEN DISPLAY CONTROLLER

8.11.11 Automatic Solid Space Function

This function generates automatically the solid space (OUT1 or OUT2 blank output) of the character area in the CC mode.

The solid space is output in the following area :

- Any character area except character code "09₁₆"
 - Character area on the left and right sides of the above character
- This function is turned on and off by bit 1 of the OSD control register (refer to Figure 8.11.3).

Notes : The character code "09₁₆" is used for "transparent space" when displaying Closed Caption. Therefore, set "00₁₆" to the 40-byte addresses corresponding to the character code "09₁₆".

<Transparent space font data storing area>
 ■ M37272M6H/M8H-XXXSP/FP, M37272E8SP/FP
 addresses 1000₁₆ + (4 + 2n) × 100₁₆ + 12₁₆ to
 1000₁₆ + (4 + 2n) × 100₁₆ + 13₁₆
 (n = 0 to 19)

addresses 1412₁₆ and 1413₁₆
 addresses 1612₁₆ and 1613₁₆
 ⋮
 addresses 3812₁₆ and 3813₁₆
 addresses 3A12₁₆ and 3A13₁₆

■ M37272MAH/MFH-XXXSP/FP, M37272EFSP/FP
 addresses 11000₁₆ + (4 + 2n) × 100₁₆ + 12₁₆ to
 11000₁₆ + (4 + 2n) × 100₁₆ + 13₁₆
 (n = 0 to 19)

addresses 11412₁₆ and 11413₁₆
 addresses 11612₁₆ and 11613₁₆
 ⋮
 addresses 13812₁₆ and 13813₁₆
 addresses 13A12₁₆ and 13A13₁₆

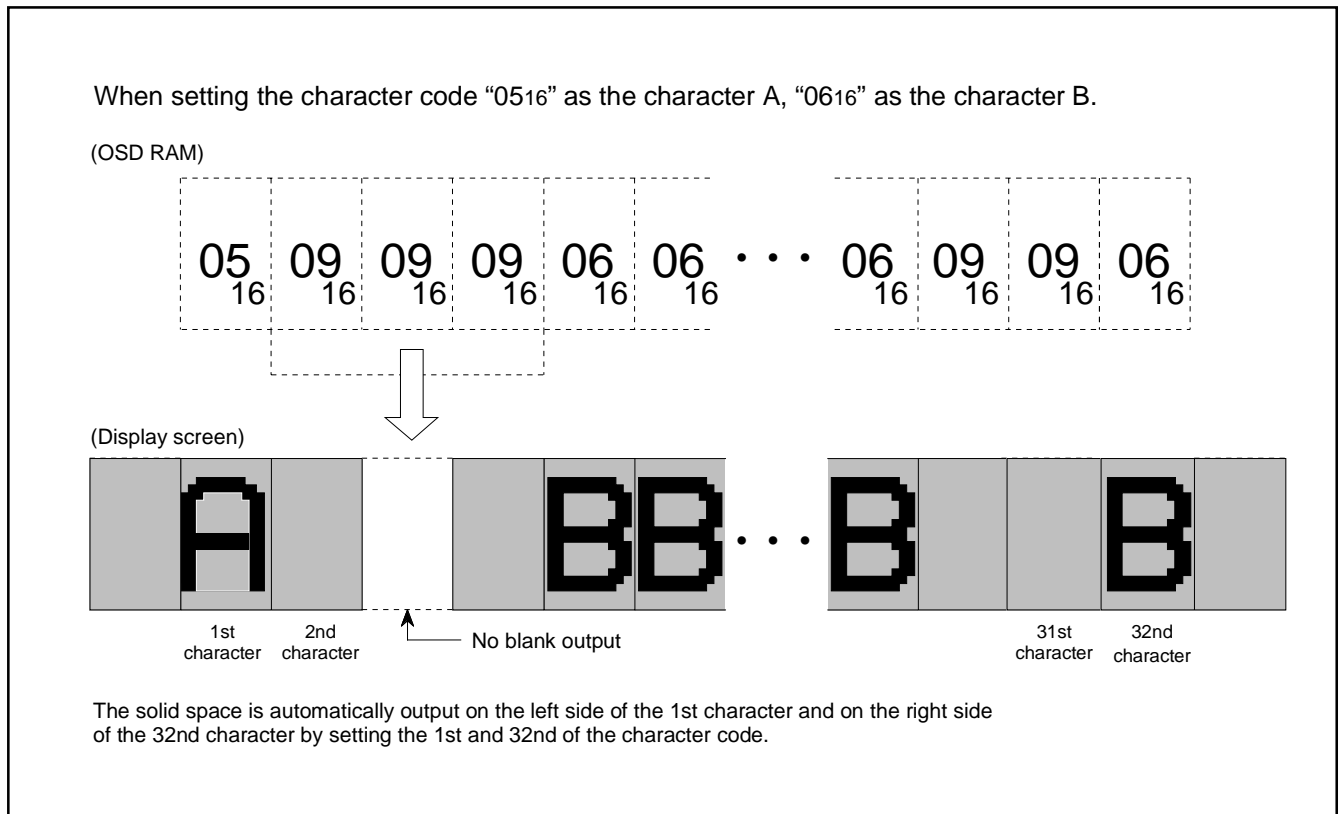

Fig. 8.11.24 Display Screen Example of Automatic Solid Space

M37272M6H/M8H/MAH/MFH-XXXSP/FP
M37272E8SP/FP, M37272EFSP/FP

SINGLE-CHIP 8-BIT CMOS MICROCOMPUTER with CLOSED CAPTION DECODER
 and ON-SCREEN DISPLAY CONTROLLER

8.11.12 Window Function

This function sets the top and bottom boundary of display limit on a screen. The window function is valid only in the CC mode. The top boundary is set by the window registers 1 and bit 7 of block control register 1. The bottom boundary is set by window registers 1 and bit 7 of block control register 2. This function is turned on and off by bit 2 of the OSD control register (refer to Figure 8.11.3).

The window registers 1 and 2 is shown in Figures 8.11.26 and 8.11.27.

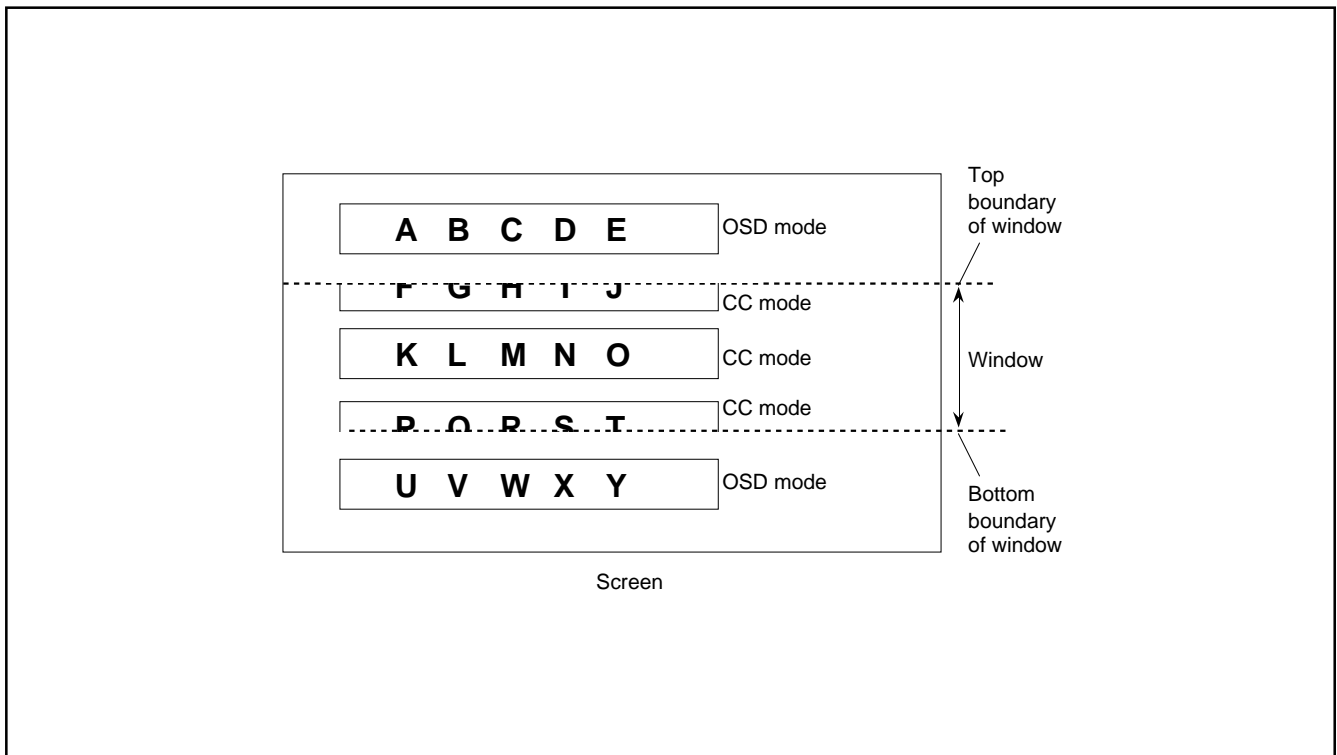
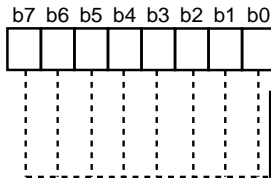

Fig. 8.11.25 Example of Window Function

M37272M6H/M8H/MAH/MFH-XXXSP/FP
M37272E8SP/FP, M37272EFSP/FP

SINGLE-CHIP 8-BIT CMOS MICROCOMPUTER with CLOSED CAPTION DECODER
 and ON-SCREEN DISPLAY CONTROLLER

Window Register 1



Window register 1 (WN1) [Address 00D6₁₆]

B	Name	Functions	After reset	R	W
0 to 7	Window top boundary control bits (WN10 to WN17)	Window top border position = $T_H \times (BC17 \times 16^2 + n)$ (n: setting value, T_H : Hsync cycle, BC17: bit 7 of block control register 1)	Inderterminate	R	W

Notes 1: Set values except 00₁₆ to WN1 when BC17 is 0.
 2: Set values fit for the following condition: WN1 < WN2.

Fig. 8.11.26 Window Register 1

Window Register 2

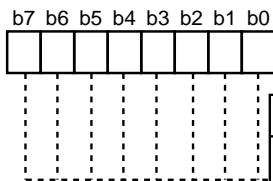

Window register 2 (WN2) [Address 00D7₁₆]

B	Name	Functions	After reset	R	W
0 to 7	Window bottom boundary control bits (WN20 to WN27)	Window bottom border position = $T_H \times (BC27 \times 16^2 + n)$ (n: setting value, T_H : Hsync cycle, BC27: bit 7 of block control register 2)	Inderterminate	R	W

Note: Set values fit for the following condition: WN1 < WN2.

Fig. 8.11.27 Window Register 2

M37272M6H/M8H/MAH/MFH-XXXSP/FP M37272E8SP/FP, M37272EFSP/FP

SINGLE-CHIP 8-BIT CMOS MICROCOMPUTER with CLOSED CAPTION DECODER
and ON-SCREEN DISPLAY CONTROLLER

8.11.13 OSD Output Pin Control

The OSD output pins R, G, B and OUT1 can also function as ports P52–P55. Set corresponding bit of the OSD port control register (address 00CB16) to “0” to specify these pins as OSD output pins, or set it to “1” to specify it as a general-purpose port P5.

The OUT2 can also function as port P10. Set bit 0 of the port P1 direction register (address 00C316) to “1” (output mode). After that, set bit 7 of the OSD port control register to “1” to specify the pin as OSD output pin, or set it to “0” to specify as port P10.

The input polarity of the HSYNC, VSYNC and output polarity of signals R, G, B, OUT1 and OUT2 can be specified with the I/O polarity control register (address 00D8) . Set a bit to “0” to specify positive polarity; set it to “1” to specify negative polarity (refer to Figure 8.11.13).

The structure of the OSD port control register is shown in Figure 8.11.28.

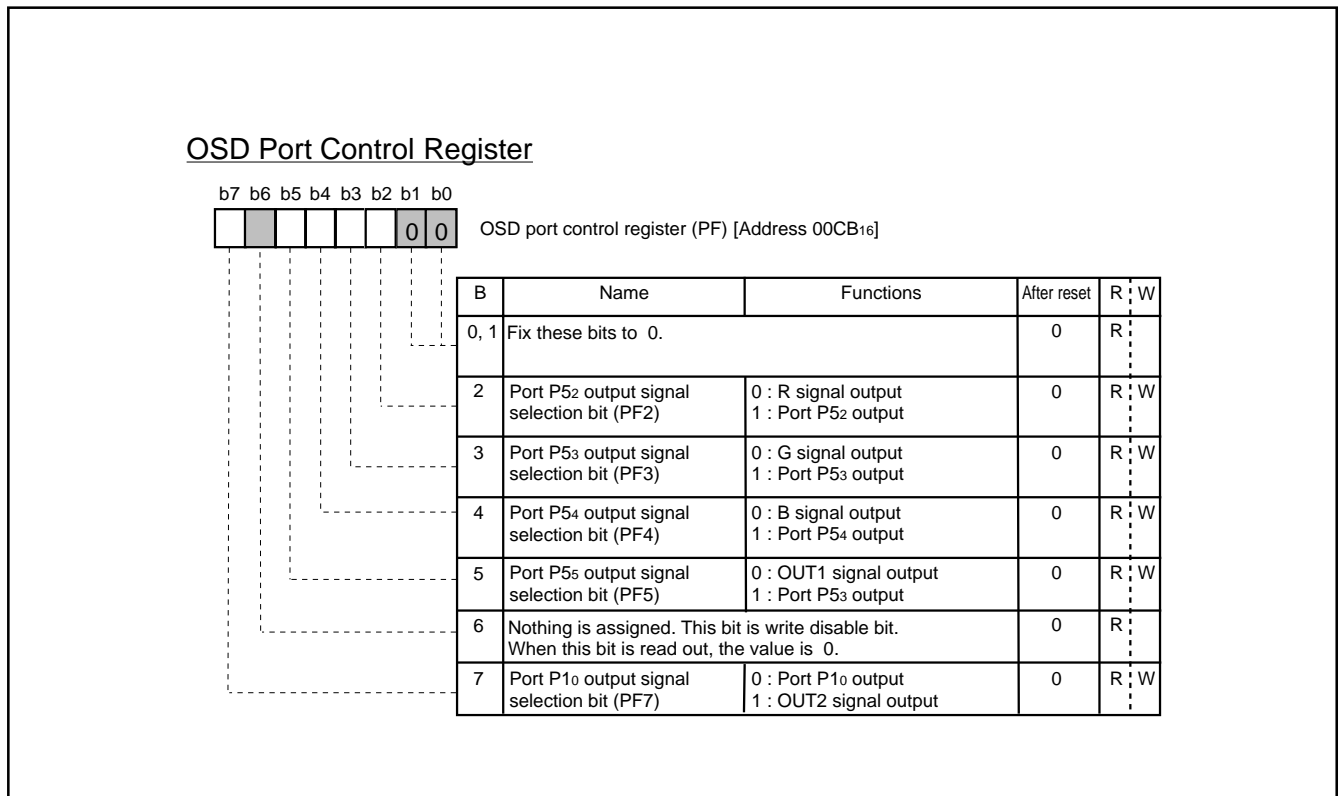

Fig. 8.11.28 OSD Port Control Register

M37272M6H/M8H/MAH/MFH-XXXSP/FP M37272E8SP/FP, M37272EFSP/FP

SINGLE-CHIP 8-BIT CMOS MICROCOMPUTER with CLOSED CAPTION DECODER
and ON-SCREEN DISPLAY CONTROLLER

8.11.14 Raster Coloring Function

An entire screen (raster) can be colored by setting the bits 4 to 0 of the raster color register. Since each of the R, G, B, OUT1, and OUT2 pins can be switched to raster coloring output, 8 raster colors can be obtained.

When the character color/the character background color overlaps with the raster color, the color (R, G, B, OUT1, OUT2), specified for the character color/the character background color, takes priority of the raster color. This ensures that character color/character background color is not mixed with the raster color.

The raster color register is shown in Figure 8.11.29, the example of raster coloring is shown in Figure 8.11.30.

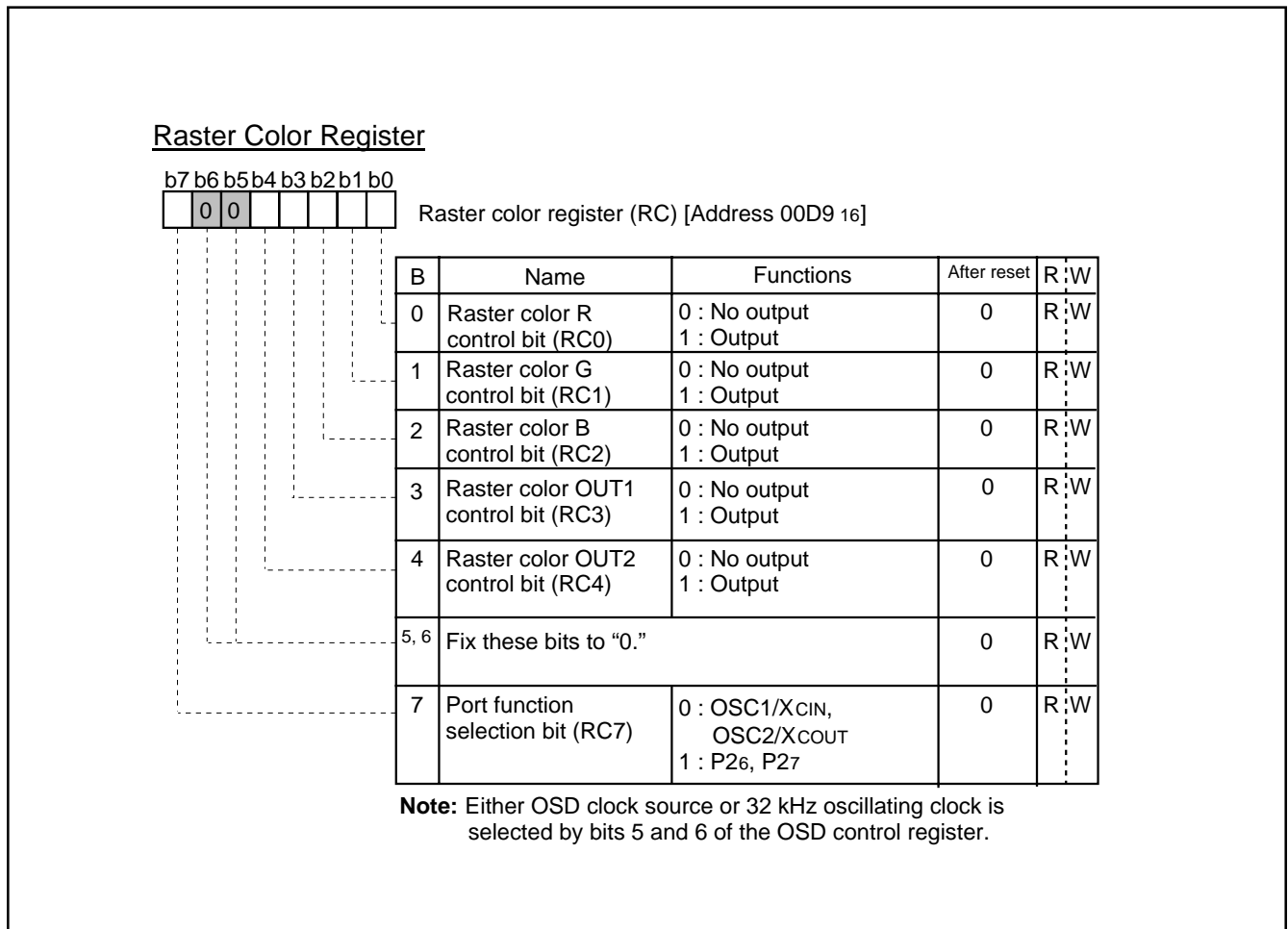

Fig. 8.11.29 Raster Color Register

M37272M6H/M8H/MAH/MFH-XXXSP/FP
M37272E8SP/FP, M37272EFSP/FP

SINGLE-CHIP 8-BIT CMOS MICROCOMPUTER with CLOSED CAPTION DECODER
 and ON-SCREEN DISPLAY CONTROLLER

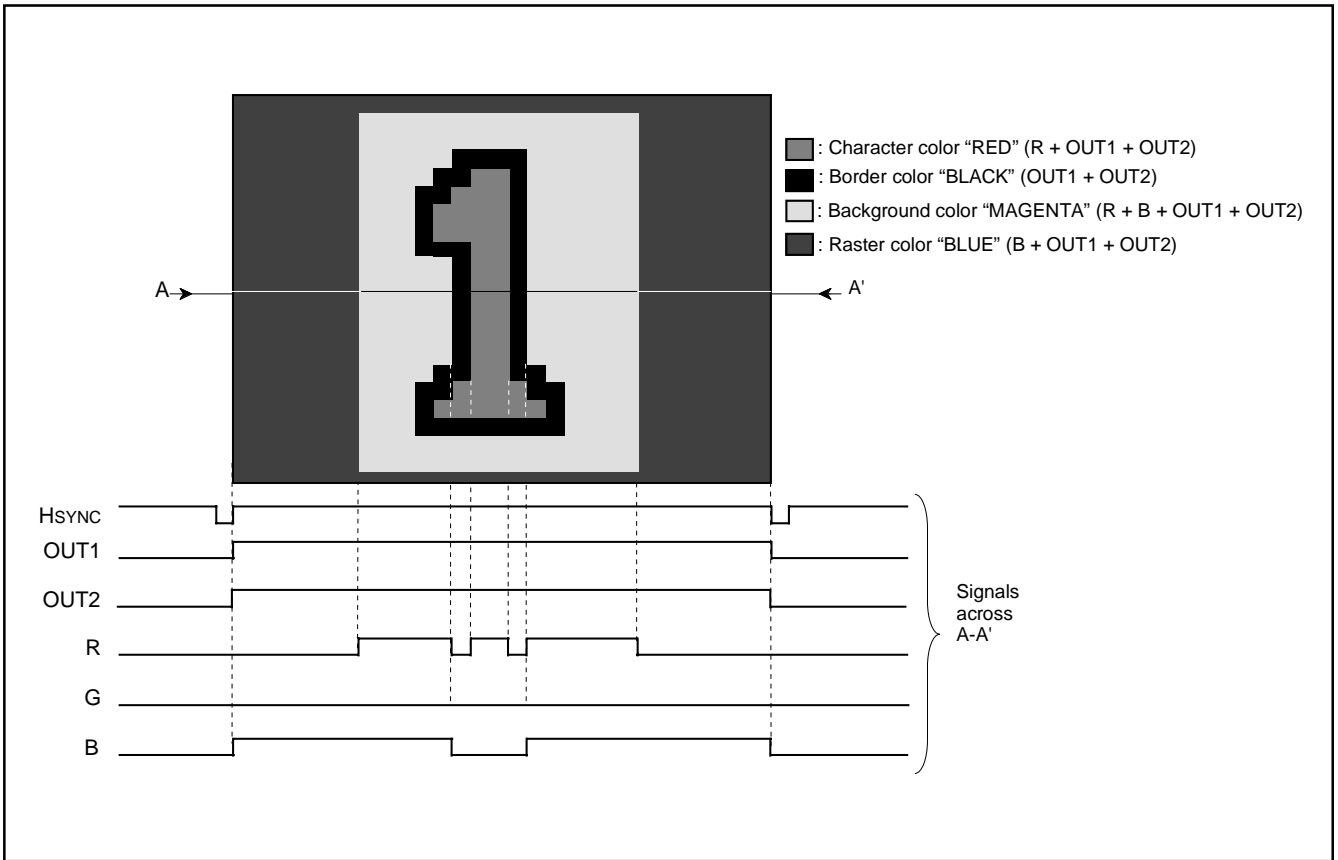

Fig. 8.11.30 Example of Raster Coloring

M37272M6H/M8H/MAH/MFH-XXXSP/FP M37272E8SP/FP, M37272EFSP/FP

SINGLE-CHIP 8-BIT CMOS MICROCOMPUTER with CLOSED CAPTION DECODER
and ON-SCREEN DISPLAY CONTROLLER

8.12 SOFTWARE RUNAWAY DETECT FUNCTION

This microcomputer has a function to decode undefined instructions to detect a software runaway.

When an undefined op-code is input to the CPU as an instruction code during operation, the following processing is done.

- ① The CPU generates an undefined instruction decoding signal.
- ② The device is internally reset because of occurrence of the undefined instruction decoding signal.
- ③ As a result of internal reset, the same reset processing as in the case of ordinary reset operation is done, and the program restarts from the reset vector.

Note, however, that the software runaway detecting function cannot be invalid.

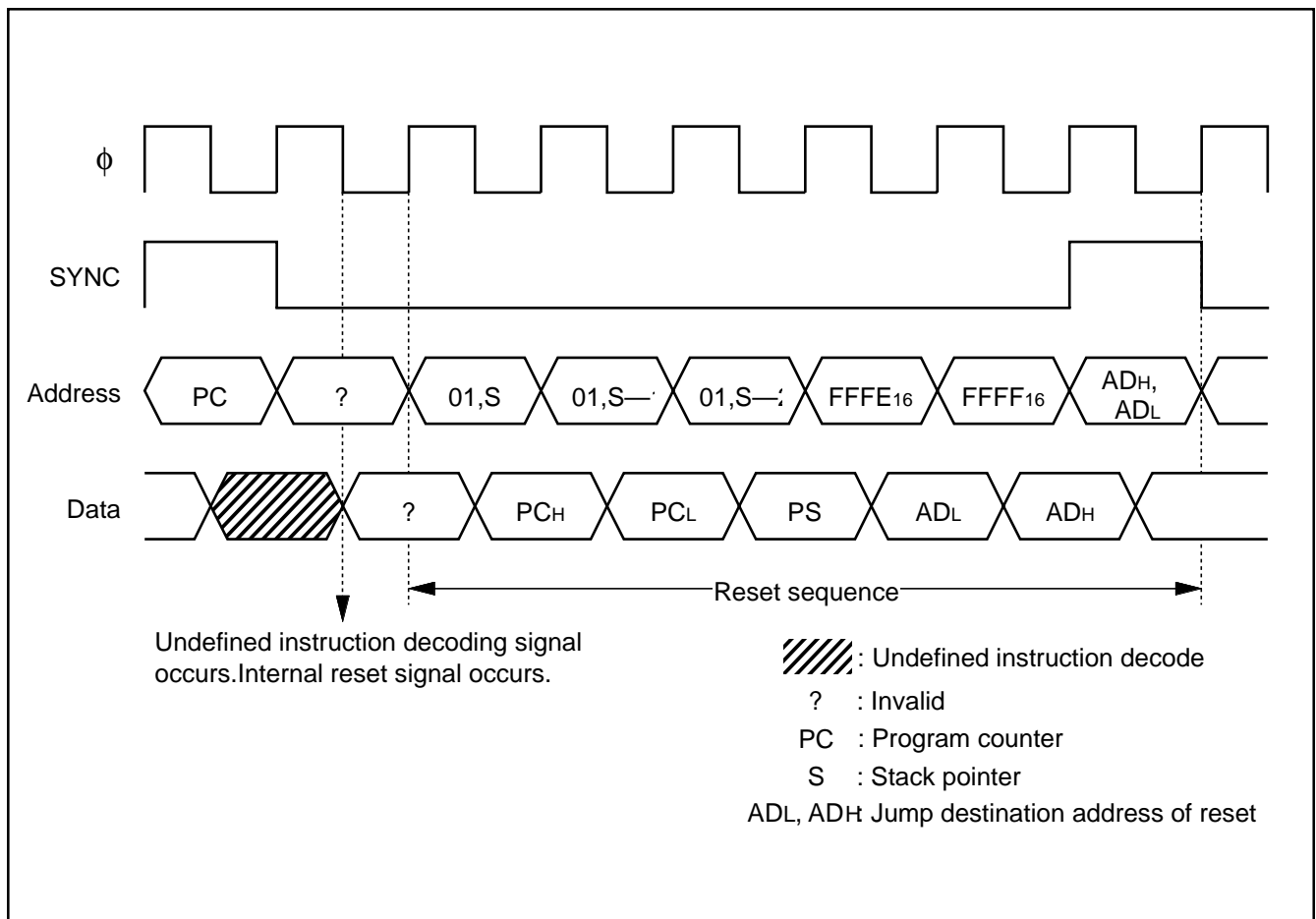

Fig.8.12.1 Sequence at Detecting Software Runaway Detection

M37272M6H/M8H/MAH/MFH-XXXSP/FP M37272E8SP/FP, M37272EFSP/FP

SINGLE-CHIP 8-BIT CMOS MICROCOMPUTER with CLOSED CAPTION DECODER
and ON-SCREEN DISPLAY CONTROLLER

8.13. RESET CIRCUIT

When the oscillation of a quartz-crystal oscillator or a ceramic resonator is stable and the power source voltage is $5\text{ V} \pm 10\%$, hold the $\overline{\text{RESET}}$ pin at LOW for $2\ \mu\text{s}$ or more, then return it to HIGH. Then, as shown in Figure 8.13.2, reset is released and the program starts from the address formed by using the content of address FFFF_{16} as the high-order address and the content of the address FFFE_{16} as the low-order address. The internal state of microcomputer at reset are shown in Figures 8.2.3 to 8.2.6.

An example of the reset circuit is shown in Figure 8.13.1.

The reset input voltage must be kept 0.9 V or less until the power source voltage surpasses 4.5 V .

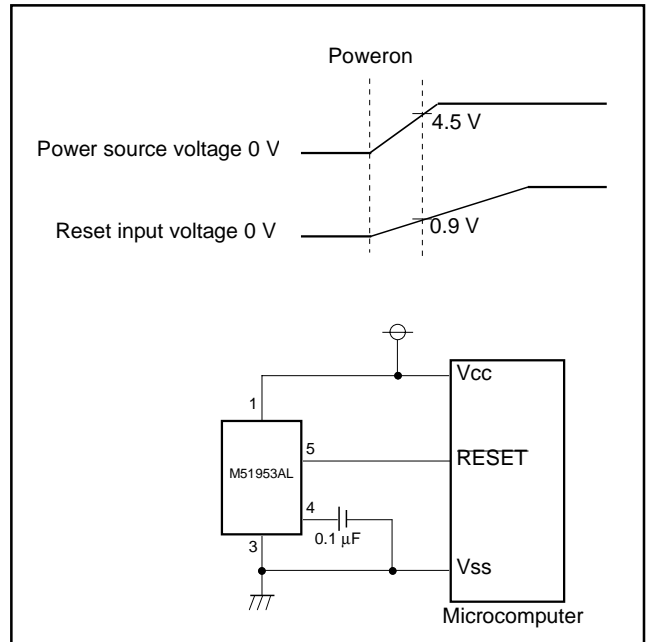

Fig.8.13.1 Example of Reset Circuit

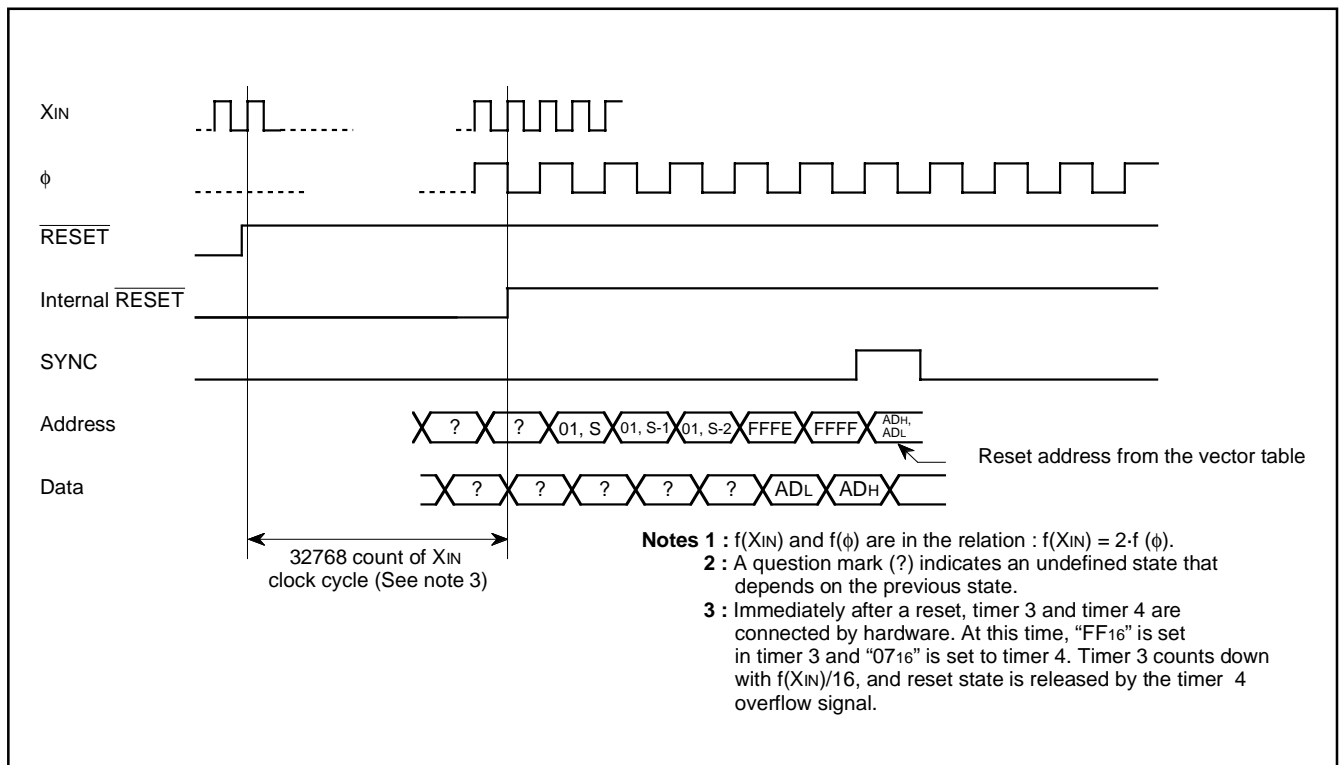

Fig.8.13.2 Reset Sequence

M37272M6H/M8H/MAH/MFH-XXXSP/FP M37272E8SP/FP, M37272EFSP/FP

SINGLE-CHIP 8-BIT CMOS MICROCOMPUTER with CLOSED CAPTION DECODER
and ON-SCREEN DISPLAY CONTROLLER

8.14 CLOCK GENERATING CIRCUIT

This microcomputer has 2 built-in oscillation circuits. An oscillation circuit can be formed by connecting a resonator between XIN and XOUT (XCIN and XCOUT). Use the circuit constants in accordance with the resonator manufacturer's recommended values. No external resistor is needed between XIN and XOUT since a feed-back resistor exists on-chip. However, an external feed-back resistor is needed between XCIN and XCOUT. When using XCIN-XCOUT as sub-clock, clear bits 5 and 6 of the OSD control register to "0." To supply a clock signal externally, input it to the XIN (XCIN) pin and make the XOUT (XCOUT) pin open. When not using XCIN clock, connect the XCIN to Vss and make the XCOUT pin open.

After reset has completed, the internal clock ϕ is half the frequency of XIN. Immediately after poweron, both the XIN and XCIN clock start oscillating. To set the internal clock ϕ to low-speed operation mode, set bit 7 of the CPU mode register to "1."

8.14.1 OSCILLATION CONTROL

(1) Stop Mode

The built-in clock generating circuit is shown in Figure 120. When the STP instruction is executed, the internal clock ϕ stops at HIGH. At the same time, timers 3 and 4 are connected by hardware and "FF16" is set in timer 3 and "0716" is set in timer 4. Select $f(XIN)/16$ or $f(XCIN)/16$ as the timer 3 count source (set both bit 0 of the timer mode register 2 and bit 6 at address 00C716 to "0" before the execution of the STP instruction). Moreover, set the timer 3 and timer 4 interrupt enable bits to disabled ("0") before execution of the STP instruction. The oscillator restarts when external interrupt is accepted. However, the internal clock ϕ keeps its HIGH level until timer 4 overflows, allowing time for oscillation stabilization when a ceramic resonator or a quartz-crystal oscillator is used.

(2) Wait Mode

When the WIT instruction is executed, the internal clock ϕ stops in the HIGH level but the oscillator continues running. This wait state is released at reset or when an interrupt is accepted (See note). Since the oscillator does not stop, the next instruction can be executed at once.

Note: In the wait mode, the following interrupts are invalid.

- VSYNC interrupt
- OSD interrupt
- All timer interrupts using external clock input from port pin as count source
- All timer interrupts using $f(XIN)/2$ or $f(XCIN)/2$ as count source
- All timer interrupts using $f(XIN)/4096$ or $f(XCIN)/4096$ as count source
- $f(XIN)/4096$ interrupt
- Multi-master I²C-BUS interface interrupt
- Data slicer interrupt
- A-D conversion interrupt

(3) Low-speed Mode

If the internal clock is generated from the sub-clock (XCIN), a low power consumption operation can be realized by stopping only the main clock XIN. To stop the main clock, set bit 6 (CM6) of the CPU mode register (00FB16) to "1." When the main clock XIN is restarted, the program must allow enough time to for oscillation to stabilize.

Note that in low-power-consumption mode the XCIN-XCOUT drivability can be reduced, allowing even lower power consumption. To reduce the XCIN-XCOUT drivability, clear bit 5 (CM5) of the CPU mode register (00FB16) to "0." At reset, this bit is set to "1" and strong drivability is selected to help the oscillation to start. When an STP instruction is executed, set this bit to "1" by software before executing.

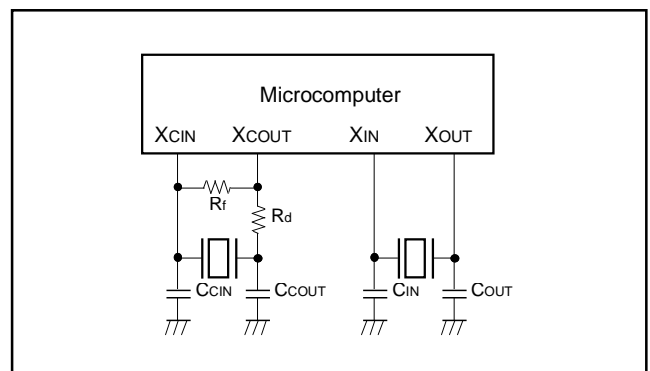

Fig.8.14.1 Ceramic Resonator Circuit Example

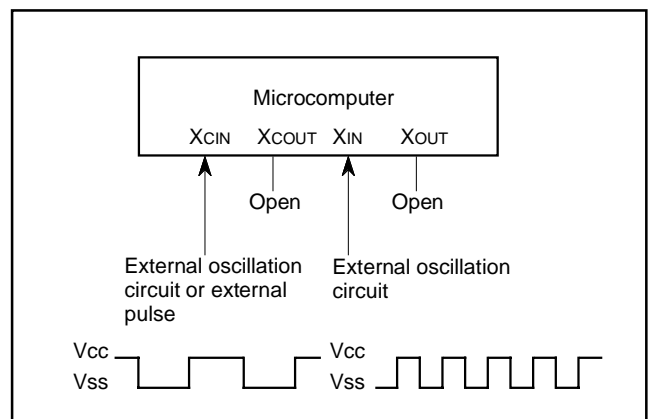

Fig.8.14.2 External Clock Input Circuit Example

M37272M6H/M8H/MAH/MFH-XXXSP/FP M37272E8SP/FP, M37272EFSP/FP

SINGLE-CHIP 8-BIT CMOS MICROCOMPUTER with CLOSED CAPTION DECODER
and ON-SCREEN DISPLAY CONTROLLER

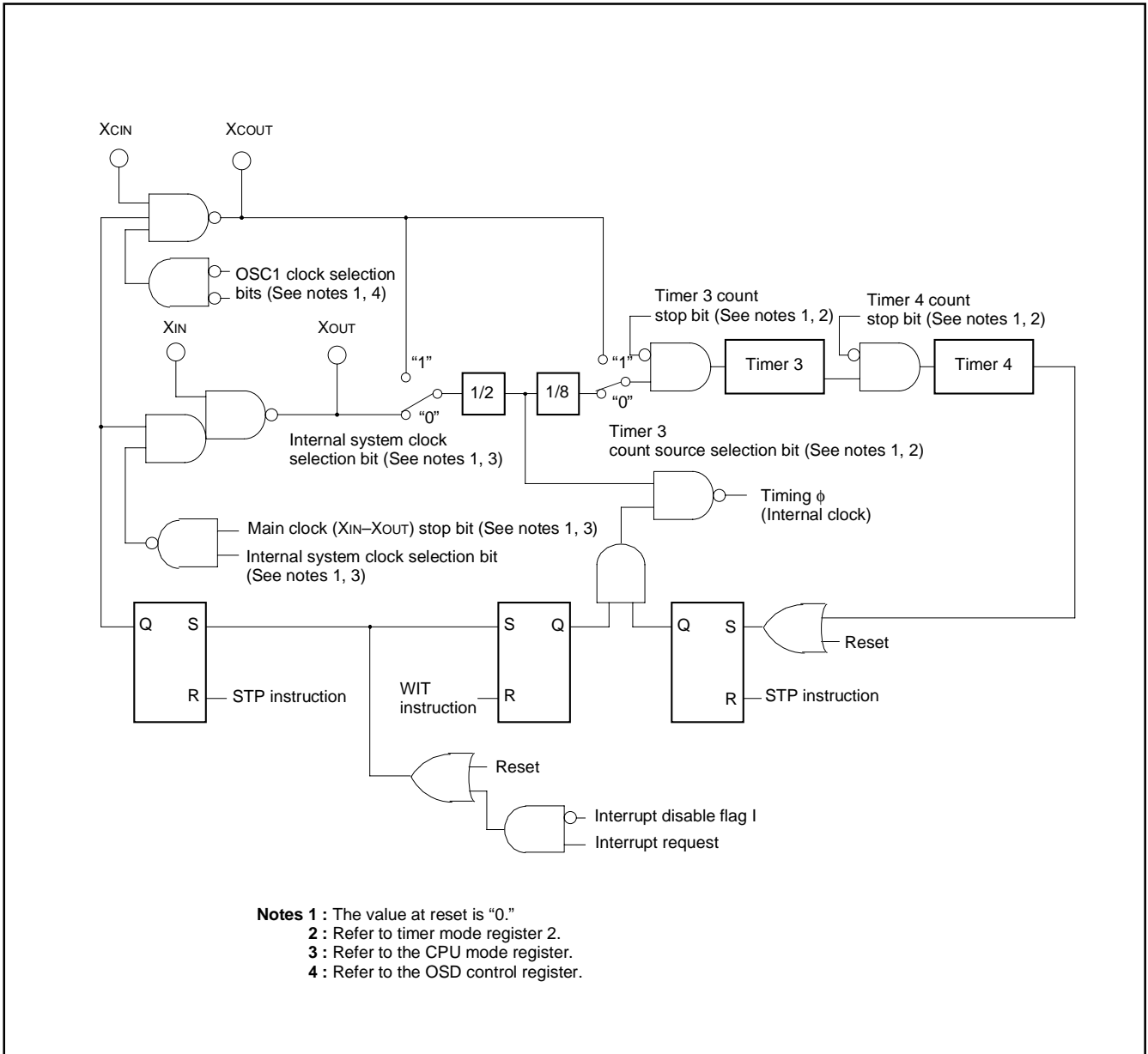
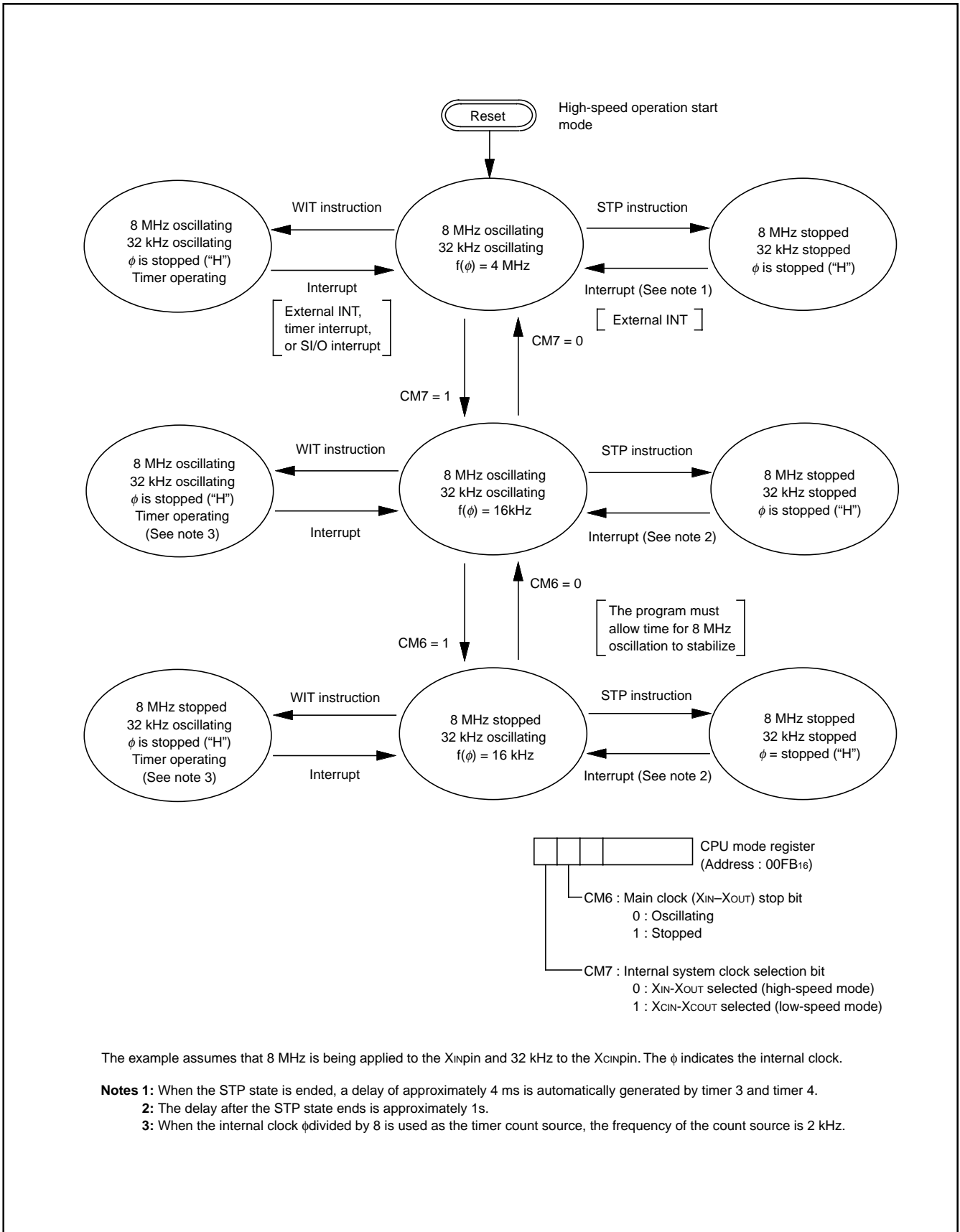

Fig.8.14.3 Clock Generating Circuit Block Diagram

M37272M6H/M8H/MAH/MFH-XXXSP/FP M37272E8SP/FP, M37272EFSP/FP

SINGLE-CHIP 8-BIT CMOS MICROCOMPUTER with CLOSED CAPTION DECODER
and ON-SCREEN DISPLAY CONTROLLER



The example assumes that 8 MHz is being applied to the X_{IN}pin and 32 kHz to the X_{CIN}pin. The ϕ indicates the internal clock.

- Notes 1: When the STP state is ended, a delay of approximately 4 ms is automatically generated by timer 3 and timer 4.
- 2: The delay after the STP state ends is approximately 1s.
- 3: When the internal clock ϕ divided by 8 is used as the timer count source, the frequency of the count source is 2 kHz.

Fig.8.14.4 State Transitions of System Clock

M37272M6H/M8H/MAH/MFH-XXXSP/FP M37272E8SP/FP, M37272EFSP/FP

SINGLE-CHIP 8-BIT CMOS MICROCOMPUTER with CLOSED CAPTION DECODER
and ON-SCREEN DISPLAY CONTROLLER

8.15 DISPLAY OSCILLATION CIRCUIT

The OSD oscillation circuit has a built-in clock oscillation circuits, so that a clock for OSD can be obtained simply by connecting an LC, a ceramic resonator, or a quartz-crystal oscillator across the pins OSC1 and OSC2. Which of the sub-clock or the OSD oscillation circuit is selected by setting bits 5 and 6 of the OSD control register (address 00D016).

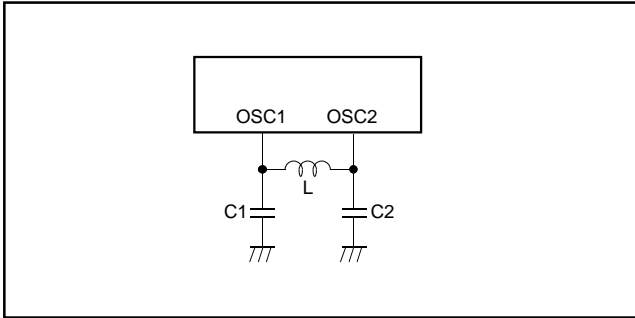

Fig.8.15.1 Display Oscillation Circuit

8.16 AUTO-CLEAR CIRCUIT

When a power source is supplied, the auto-clear function will operate by connecting the following circuit to the $\overline{\text{RESET}}$ pin.

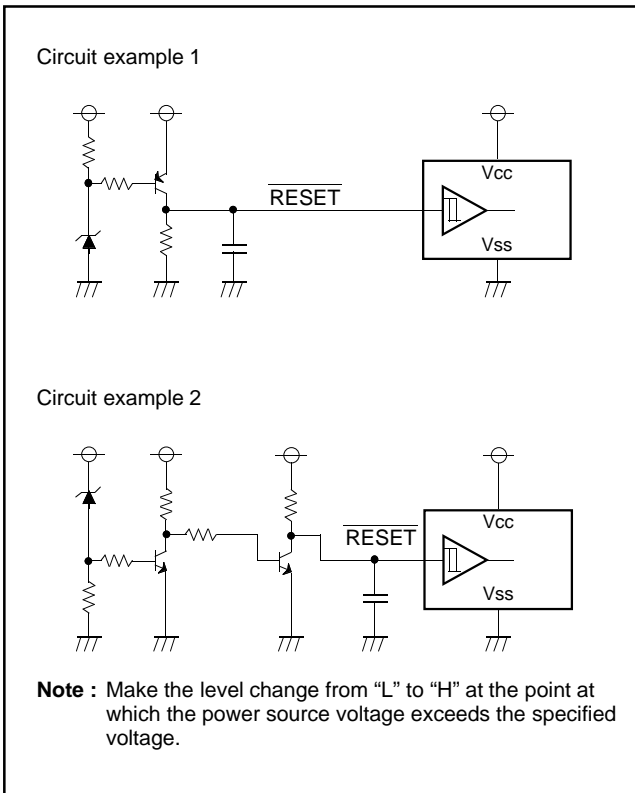

Fig.8.16.1 Auto-clear Circuit Example

8.17 ADDRESSING MODE

The memory access is reinforced with 17 kinds of addressing modes. Refer to SERIES 740 <Software> User's Manual for details.

8.18 MACHINE INSTRUCTIONS

There are 71 machine instructions. Refer to SERIES 740 <Software> User's Manual for details.

9. PROGRAMMING NOTES

- The divide ratio of the timer is $1/(n+1)$.
- Even though the BBC and BBS instructions are executed immediately after the interrupt request bits are modified (by the program), those instructions are only valid for the contents before the modification. At least one instruction cycle is needed (such as an NOP) between the modification of the interrupt request bits and the execution of the BBC and BBS instructions.
- After the ADC and SBC instructions are executed (in the decimal mode), one instruction cycle (such as an NOP) is needed before the SEC, CLC, or CLD instruction is executed.
- An NOP instruction is needed immediately after the execution of a PLP instruction.
- In order to avoid noise and latch-up, connect a bypass capacitor ($\approx 0.1\mu\text{F}$) directly between the VCC pin-VSS pin, AVCC pin-VSS pin, and the VCC pin-CNVSS pin, using a thick wire.
- M37272M6H/M8H/MAH/MFH-XXXSP/FP and M37272E8SP/FP, M37272EFSP/FP are compatible, but please attention differences as follows:

Parameter	M37272E8/EF		M37272MXH	
	Spec of 1 4th pins		NC (Non connection)	
Power source voltage	Normal	Max.	Normal	Max.
When System operate				
$f(\text{XIN}) : 8\text{MHz}$	OSD : OFF Data slicer : OFF	15 mA	30 mA	10 mA
	OSD : ON Data slicer : ON	30mA	45 mA	25 mA

* Need to apply $5\text{V} \pm 10\%$ (Typical), because 14th pin of M37272E8SP/FP, M37272EFSP/FP is AVCC pin. 14 pin of M37272M6H/M8H/MAH/MFH-XXXSP/FP is the non connection pin, but it is not connect in IC. You can apply voltage.

M37272M6H/M8H/MAH/MFH-XXXSP/FP M37272E8SP/FP, M37272EFSP/FP

SINGLE-CHIP 8-BIT CMOS MICROCOMPUTER with CLOSED CAPTION DECODER
and ON-SCREEN DISPLAY CONTROLLER

10. ABSOLUTE MAXIMUM RATINGS

Symbol	Parameter	Conditions	Ratings	Unit
V _{CC} (AV _{CC})	Power source voltage V _{CC} (AV _{CC} ...M37272E8SP/FP, M37272EFSP/FP)	All voltages are based on V _{SS} . Output transistors are cut off.	-0.3 to 6	V
V _I	Input voltage CNV _{SS}		-0.3 to 6	V
V _I	Input voltage P00-P07, P10-P17, P20-P27, P30, P31, P50, P51, X _{IN} , RESET, CV _{IN}		-0.3-V _{CC} + 0.3	V
V _O	Output voltage P06, P07, P10-P17, P20-P27, P30, P31, P52-P55, X _{OUT}		-0.3-V _{CC} + 0.3	V
V _O	Output voltage P00-P05		-0.3 to 13	V
I _{OH}	Circuit current P10-P17, P20-P27, P30, P31, P52-P55		0 to 1 (See note 1)	mA
I _{OL1}	Circuit current P06, P07, P10, P15-P17, P20-P23, P26, P27, P52-P55		0 to 2 (See note 2)	mA
I _{OL2}	Circuit current P11-P14		0 to 6 (See note 2)	mA
I _{OL3}	Circuit current P00-P05		0 to 1 (See note 2)	mA
I _{OL4}	Circuit current P24, P25, P30, P31		0 to 10 (See note 3)	mA
P _d	Power dissipation	T _a = 25 °C	550	mW
T _{opr}	Operating temperature		-10 to 70	°C
T _{stg}	Storage temperature		-40 to 125	°C

11. RECOMMENDED OPERATING CONDITIONS (T_a = -10 °C to 70 °C, V_{CC} = 5 V ± 10 %, unless otherwise noted)

Symbol	Parameter	Limits			Unit
		Min.	Typ.	Max.	
V _{CC} (AV _{CC})	Power source voltage (See note 4) (AV _{CC} ...M37272E8SP/FP, M37272EFSP/FP)	4.5	5.0	5.5	V
V _{SS}	Power source voltage	0	0	0	V
V _{IH1}	HIGH Input voltage P00-P07, P10-P17, P20-P27, P30, P31, P50, P51, RESET, X _{IN}	0.8 V _{CC}		V _{CC}	V
V _{IH2}	HIGH Input voltage SCL1, SCL2, SDA1, SDA2 (When using I ² C-BUS)	0.7 V _{CC}		V _{CC}	V
V _{IL1}	LOW Input voltage P00-P07, P10-P17, P20-P27, P30, P31	0		0.4 V _{CC}	V
V _{IL2}	LOW Input voltage SCL1, SCL2, SDA1, SDA2 (When using I ² C-BUS)	0		0.3 V _{CC}	V
V _{IL3}	LOW Input voltage (See note 6) P50, P51, RESET, X _{IN} , OSC1, TIM2, TIM3, INT1, INT2, INT3, S _{IN} , SCLK	0		0.2 V _{CC}	V
I _{OH}	HIGH average output current (See note 1) P10-P17, P20-P27, P30, P31, P52-P55			1	mA
I _{OL1}	LOW average output current (See note 2) P06, P07, P10, P15-P17, P20-P23, P26, P27, P52-P55			2	mA
I _{OL2}	LOW average output current (See note 2) P11-P14			6	mA
I _{OL3}	LOW average output current (See note 2) P00-P05			1	mA
I _{OL4}	LOW average output current (See note 3) P24, P25, P30, P31			10	mA
f(X _{IN})	Oscillation frequency (for CPU operation) (See note 5) X _{IN}	7.9	8.0	8.1	MHz
f(X _{CIN})	Oscillation frequency (for sub-clock operation) X _{CIN}	29	32	35	kHz
f _{OSC}	Oscillation frequency (for OSD) OSC1	26.5	27.0	27.0	MHz
f _{ns1}	Input frequency TIM2, TIM3, INT1, INT2, INT3			100	kHz
f _{ns2}	Input frequency SCLK			1	MHz
f _{ns3}	Input frequency SCL1, SCL2			400	kHz
f _{ns4}	Input frequency Horizontal sync. signal of video signal	15.262	15.734	16.206	kHz
V _I	Input amplitude video signal CV _{IN}	1.5	2.0	2.5	V

M37272M6H/M8H/MAH/MFH-XXXSP/FP
M37272E8SP/FP, M37272EFSP/FP

SINGLE-CHIP 8-BIT CMOS MICROCOMPUTER with CLOSED CAPTION DECODER
 and ON-SCREEN DISPLAY CONTROLLER

12. ELECTRIC CHARACTERISTICS ($V_{CC} = 5\text{ V} \pm 10\%$, $V_{SS} = 0\text{ V}$, $f(X_{IN}) = 8\text{ MHz}$, $T_a = -10\text{ }^\circ\text{C}$ to $70\text{ }^\circ\text{C}$, unless otherwise noted)

Symbol	Parameter	Test conditions	Limits			Unit	Test circuit	
			Min.	Typ.	Max.			
I _{CC}	Power source current	System operation $V_{CC} = 5.5\text{ V}$, $f(X_{IN}) = 8\text{ MHz}$ Upper row...M37272M* (Lower row...M37272E8/EF)	OSD OFF Data slicer OFF	10 (15)	25 (30)	mA	1	
			OSD ON Data slicer ON	25 (30)	40 (45)			
		Wait mode	$V_{CC} = 5.5\text{ V}$, $f(X_{IN}) = 0$, $f(X_{CIN}) = 32\text{ kHz}$, OSD OFF, Data slicer OFF, Low-power dissipation mode set (CM5 = "0", CM6 = "1")	$V_{CC} = 5.5\text{ V}$, $f(X_{IN}) = 8\text{ MHz}$	2	4		mA
				$V_{CC} = 5.5\text{ V}$, $f(X_{IN}) = 0$, $f(X_{CIN}) = 32\text{ kHz}$, Low-power dissipation mode set (CM5 = "0", CM6 = "1")	25	100		μA
		Stop mode	$V_{CC} = 5.5\text{ V}$, $f(X_{IN}) = 0$, $f(X_{CIN}) = 0$		1	10		
V _{OH}	HIGH output voltage P10-P17, P20-P27, P30, P31, P52-P55	$V_{CC} = 4.5\text{ V}$ I _{OH} = -0.5 mA	2.4			V	2	
V _{OL}	LOW output voltage P00-P07, P10, P15-P17, P20-P23, P26, P27, P52-P55	$V_{CC} = 4.5\text{ V}$ I _{OL} = 0.5 mA			0.4	V		
	LOW output voltage P24, P25, P30, P31	$V_{CC} = 4.5\text{ V}$ I _{OL} = 10.0 mA			3.0			
	LOW output voltage P11-P14	$V_{CC} = 4.5\text{ V}$	I _{OL} = 3 mA		0.4			
					I _{OL} = 6 mA	0.6		
V _{T+} -V _{T-}	Hysteresis (See note 6) RESET, P50, P51, INT1, INT2, INT3, TIM2, TIM3, S _{IN} , S _{CLK} , S _{CL1} , S _{CL2} , S _{DA1} , S _{DA2}	$V_{CC} = 5.0\text{ V}$		0.5	1.3	V	3	
I _{IZH}	HIGH input leak current P06, P07, P10-P17, P20-P27, P30, P31, RESET, P50, P51,	$V_{CC} = 5.5\text{ V}$ V _I = 5.5 V			5	μA	4	
I _{IZL}	HIGH input leak current P00-P07, P10-P17, P20-P27, P30, P31, P50, P51, RESET	$V_{CC} = 5.5\text{ V}$ V _I = 0 V			5	μA	4	
I _{OZH}	HIGH output leak current P00-P05	$V_{CC} = 5.5\text{ V}$ V _I = 12 V			10	μA	5	
R _{BS}	I ² C-BUS • BUS switch connection resistor (between S _{CL1} and S _{CL2} , S _{DA1} and S _{DA2})	$V_{CC} = 4.5\text{ V}$			130	Ω	6	

- Notes 1:** The total current that flows out of the IC must be 20 mA or less.
2: The total input current to IC (I_{OL1} + I_{OL2} + I_{OL3}) must be 30 mA or less.
3: The total average input current for ports P30, P31, P24 and P25 and AV_{CC}-V_{SS} to IC must be 20 mA or less.
4: Connect 0.1 μF or more capacitor externally between the power source pins V_{CC}-V_{SS} so as to reduce power source noise. When use M37272E8SP/FP and M37272EFSP/FP, connect 0.1 μF or more capacitor externally between the pins AV_{CC}-V_{SS} so as to reduce power source noise. Also connect 0.1 μF or more capacitor externally between the pins V_{CC}-CNV_{SS}.
5: Use a quartz-crystal oscillator or a ceramic resonator for the CPU oscillation circuit. When using the data slicer, use 8 MHz.
6: P06, P07, P15, P23, P24 have the hysteresis when these pins are used as interrupt input pins or timer input pins. P11-P14 have the hysteresis when these pins are used as multi-master I²C-BUS interface ports. P20-P22 have the hysteresis when these pins are used as serial I/O pins.
7: Pin names in each parameter is described as below.
 (1) Dedicated pins: dedicated pin names.
 (2) Duple-/triple-function ports
 • When the same limits: I/O port name.
 • When the limits of functions except ports are different from I/O port limits: function pin name.

M37272M6H/M8H/MAH/MFH-XXXSP/FP M37272E8SP/FP, M37272EFSP/FP

SINGLE-CHIP 8-BIT CMOS MICROCOMPUTER with CLOSED CAPTION DECODER
and ON-SCREEN DISPLAY CONTROLLER

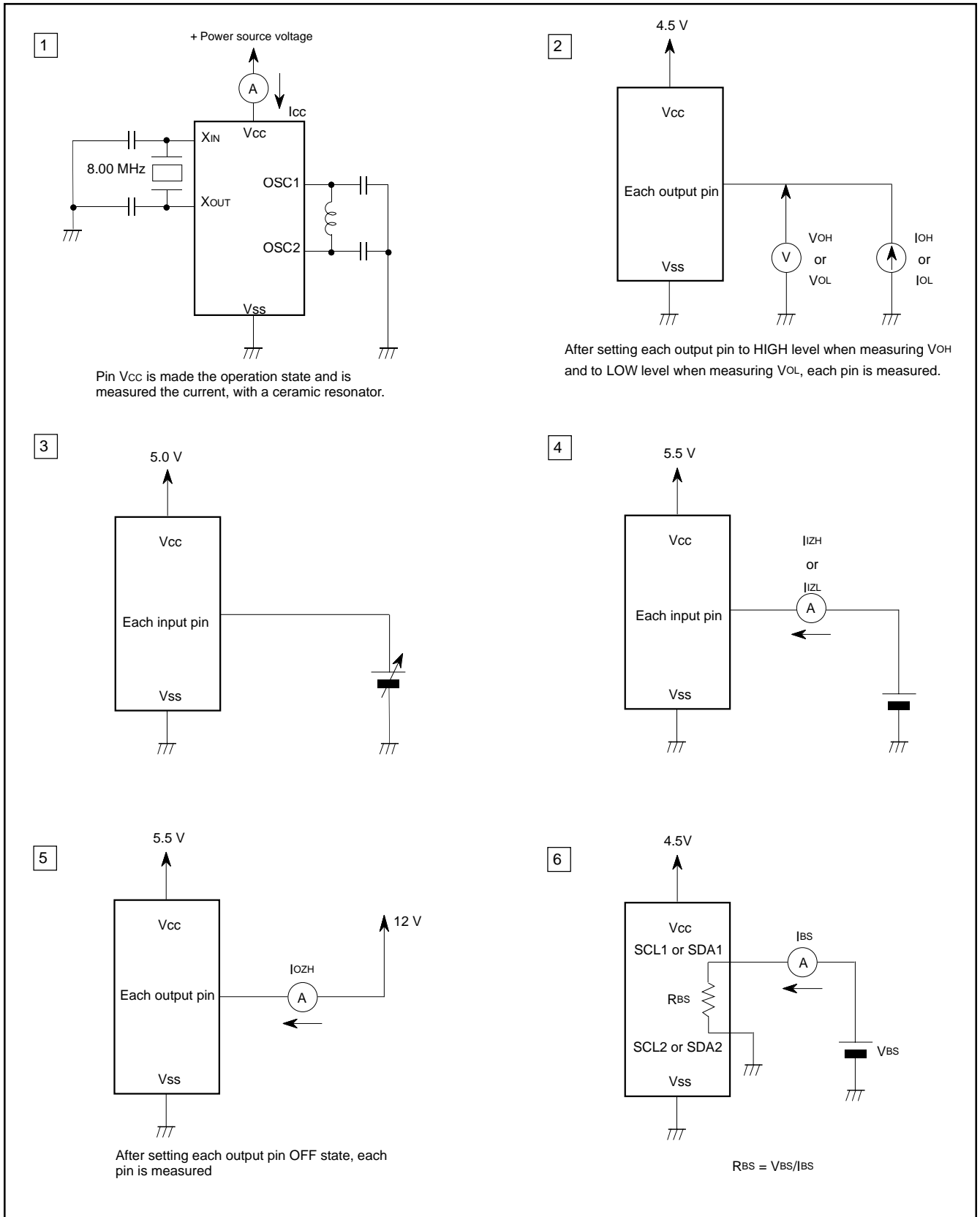

Fig.12.1 Measure Circuits

M37272M6H/M8H/MAH/MFH-XXXSP/FP M37272E8SP/FP, M37272EFSP/FP

SINGLE-CHIP 8-BIT CMOS MICROCOMPUTER with CLOSED CAPTION DECODER
and ON-SCREEN DISPLAY CONTROLLER

13. A-D CONVERTER CHARACTERISTICS

(VCC = 5 V ± 10 %, VSS = 0 V, f(XIN) = 8 MHz, Ta = -10 °C to 70 °C, unless otherwise noted)

Symbol	Parameter	Test conditions	Limits			Unit
			Min.	Typ.	Max.	
—	Resolution				6	bits
—	Non-linearity error				±1	LSB
—	Differential non-linearity error				±0.9	LSB
V0T	Zero transition error	IOL (SUM) = 0 mA			2	LSB
VFST	Full-scale transition error				-2	LSB

14. MULTI-MASTER I²C-BUS BUS LINE CHARACTERISTICS

Symbol	Parameter	Standard clock mode		High-speed clock mode		Unit
		Min.	Max.	Min.	Max.	
tBUF	Bus free time	4.7		1.3		μs
tHD; STA	Hold time for START condition	4.0		0.6		μs
tLOW	LOW period of SCL clock	4.7		1.3		μs
tR	Rising time of both SCL and SDA signals		1000	20+0.1Cb	300	ns
tHD; DAT	Data hold time	0		0	0.9	μs
tHIGH	HIGH period of SCL clock	4.0		0.6		μs
tF	Falling time of both SCL and SDA signals		300	20+0.1Cb	300	ns
tsu; DAT	Data set-up time	250		100		ns
tsu; STA	Set-up time for repeated START condition	4.7		0.6		μs
tsu; STO	Set-up time for STOP condition	4.0		0.6		μs

Note: Cb = total capacitance of 1 bus line

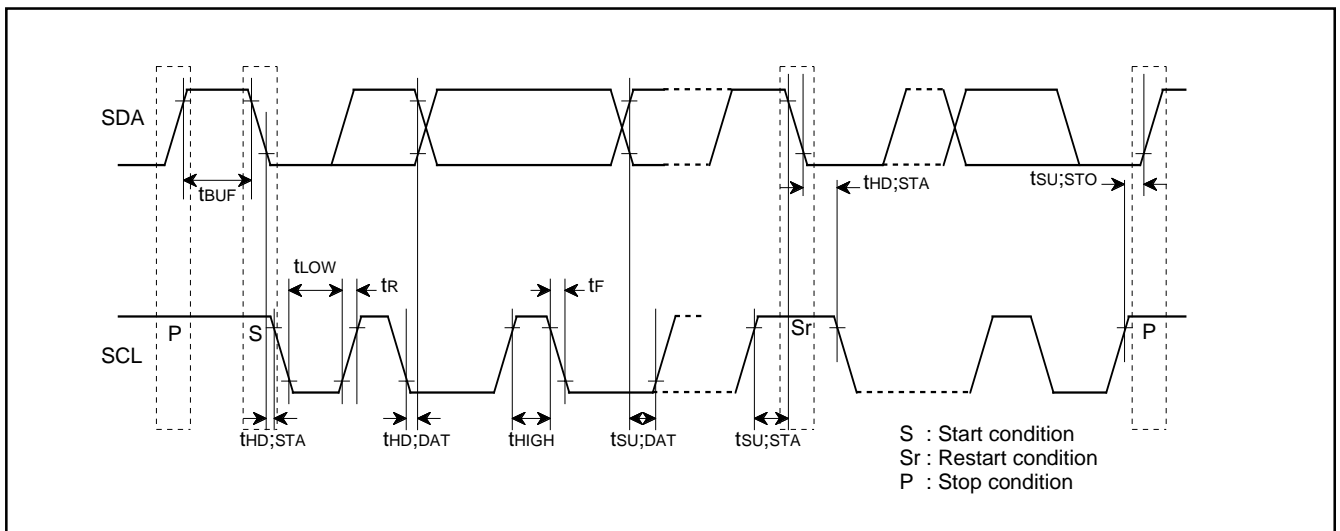

Fig.14.1 Definition Diagram of Timing on Multi-master I²C-BUS

M37272M6H/M8H/MAH/MFH-XXXSP/FP M37272E8SP/FP, M37272EFSP/FP

SINGLE-CHIP 8-BIT CMOS MICROCOMPUTER with CLOSED CAPTION DECODER
and ON-SCREEN DISPLAY CONTROLLER

15. PROM PROGRAMMING METHOD

The built-in PROM of the One Time PROM version (blank) and the built-in EPROM version can be read or programmed with a general-purpose PROM programmer using a special programming adapter.

Product	Name of Programming Adapter
M37272EFSP	PCA7429G02
M37272E8SP	PCA7429G02
M37272E8FP, M37272EFP	PCA7427G02

The PROM of the One Time PROM version (blank) is not tested or screened in the assembly process nor any following processes. To ensure proper operation after programming, the procedure shown in Figure 15.1 is recommended to verify programming.

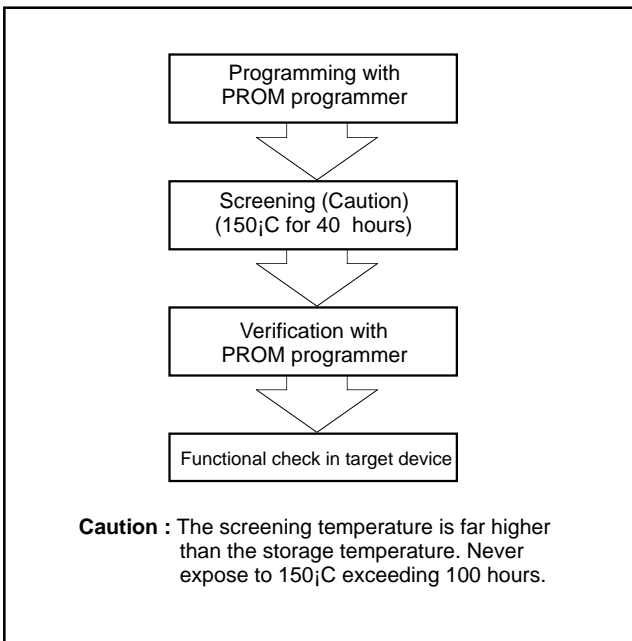

Fig. 15.1 Programming and Testing of One Time PROM Version

**M37272M6H/M8H/MAH/MFH-XXXSP/FP
M37272E8SP/FP, M37272EFSP/FP**

SINGLE-CHIP 8-BIT CMOS MICROCOMPUTER with CLOSED CAPTION DECODER
and ON-SCREEN DISPLAY CONTROLLER

16. DATA REQUIRED FOR MASK ORDERS

The following are necessary when ordering a mask ROM production:

- Mask ROM Order Confirmation Form
- Mask Specification Form
- Data to be written to ROM, in EPROM form (three identical copies) or FDK

When using EPROM:

<M37272M6H/M8H-XXXSP/FP, M37272E8SP/FP>

28-pin DIP Type 27512

<M37272MAH/MFH-XXXSP/FP, M37272EFSP/FP>

32-pin DIP Type 27C101

M37272M6H/M8H/MAH/MFH-XXXSP/FP M37272E8SP/FP, M37272EFSP/FP

SINGLE-CHIP 8-BIT CMOS MICROCOMPUTER with CLOSED CAPTION DECODER
and ON-SCREEN DISPLAY CONTROLLER

17. ONE TIME PROM VERSION M37272E8SP/FP, M37272EFSP/FP MARKING

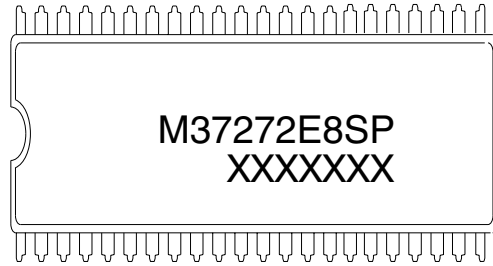

XXXXXXX is mitsubishi lot number

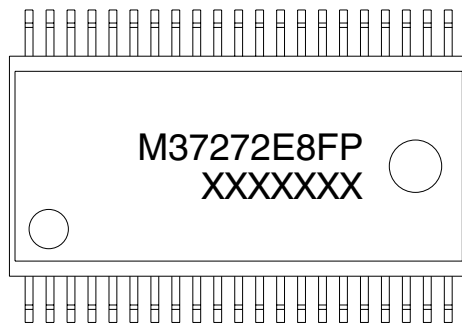

XXXXXXX is mitsubishi lot number

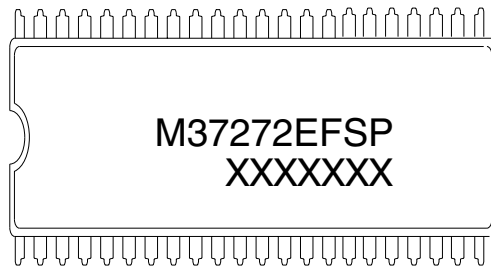

XXXXXXX is mitsubishi lot number

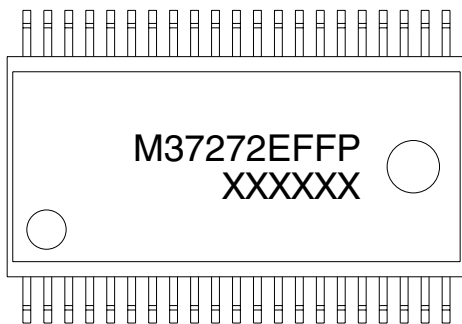

XXXXXXX is mitsubishi lot number

M37272M6H/M8H/MAH/MFH-XXXSP/FP M37272E8SP/FP, M37272EFSP/FP

SINGLE-CHIP 8-BIT CMOS MICROCOMPUTER with CLOSED CAPTION DECODER
and ON-SCREEN DISPLAY CONTROLLER

18. APPENDIX

Pin Configuration (TOP VIEW)

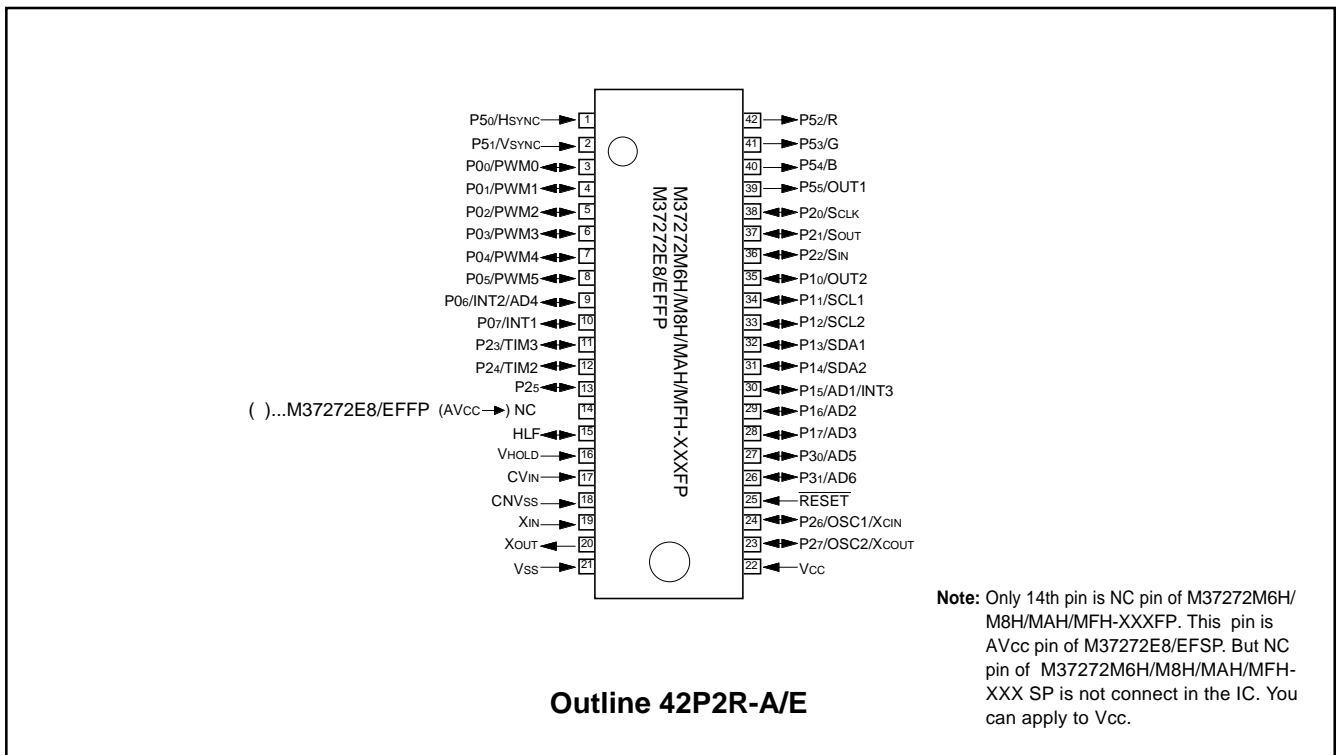
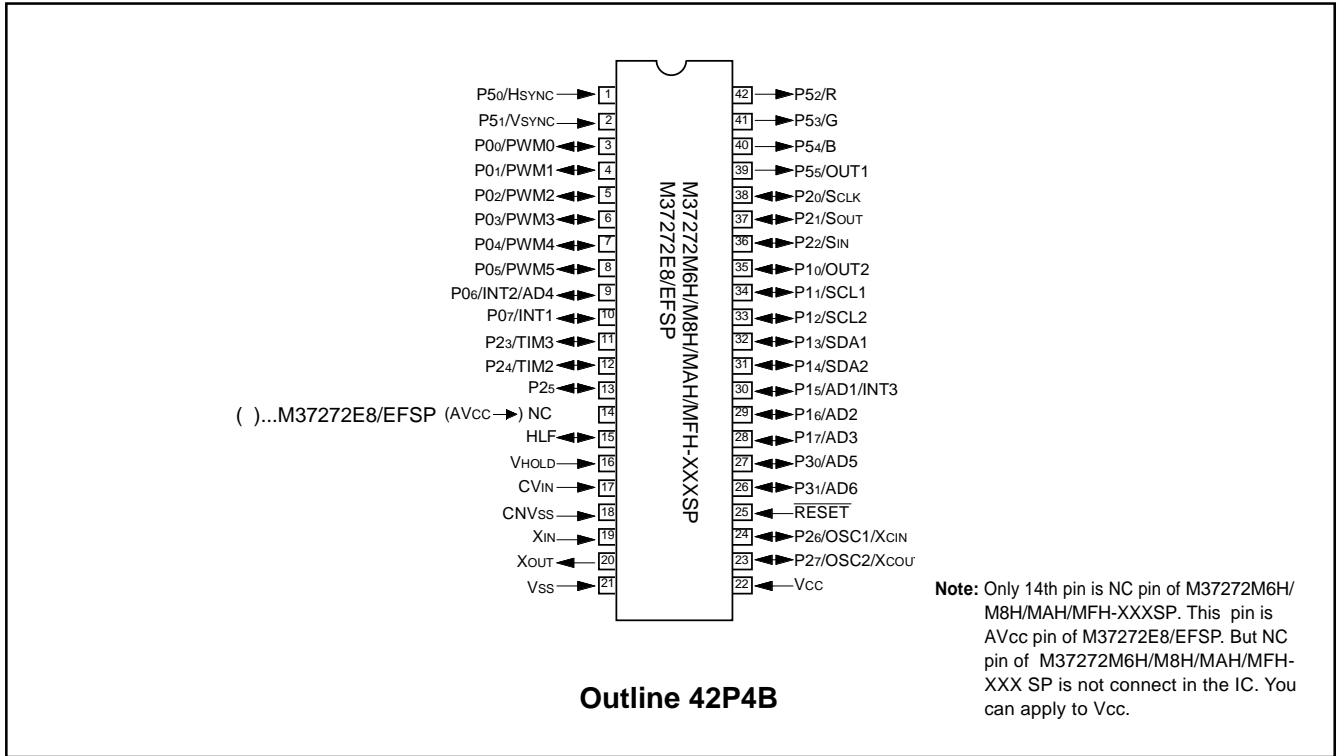

M37272M6H/M8H/MAH/MFH-XXXSP/FP M37272E8SP/FP, M37272EFSP/FP

SINGLE-CHIP 8-BIT CMOS MICROCOMPUTER with CLOSED CAPTION DECODER
and ON-SCREEN DISPLAY CONTROLLER

Memory Map

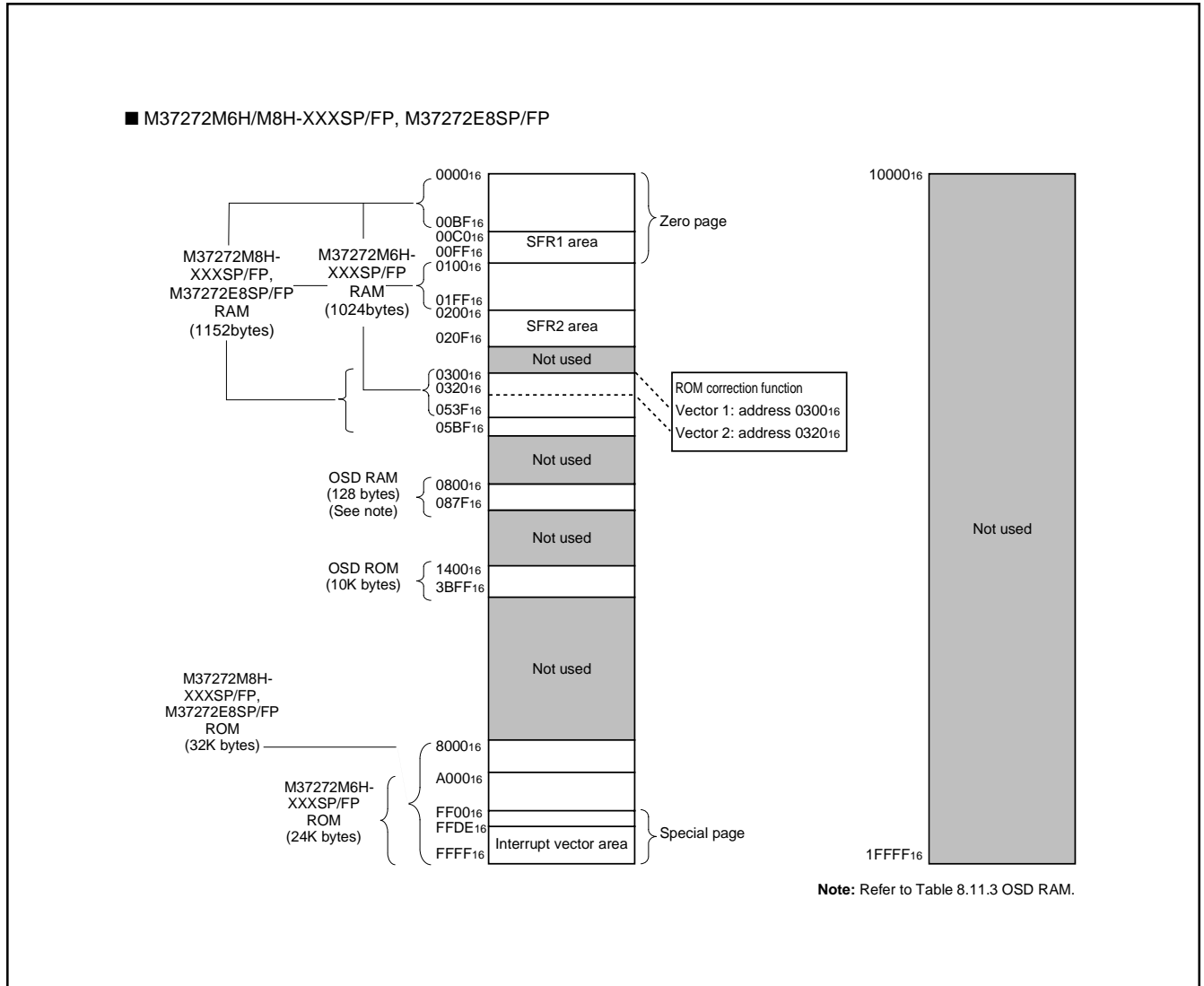

M37272M6H/M8H/MAH/MFH-XXXSP/FP M37272E8SP/FP, M37272EFSP/FP

SINGLE-CHIP 8-BIT CMOS MICROCOMPUTER with CLOSED CAPTION DECODER
and ON-SCREEN DISPLAY CONTROLLER

■ M37272MAH/MFH-XXXSP/FP, M37272EFSP/FP

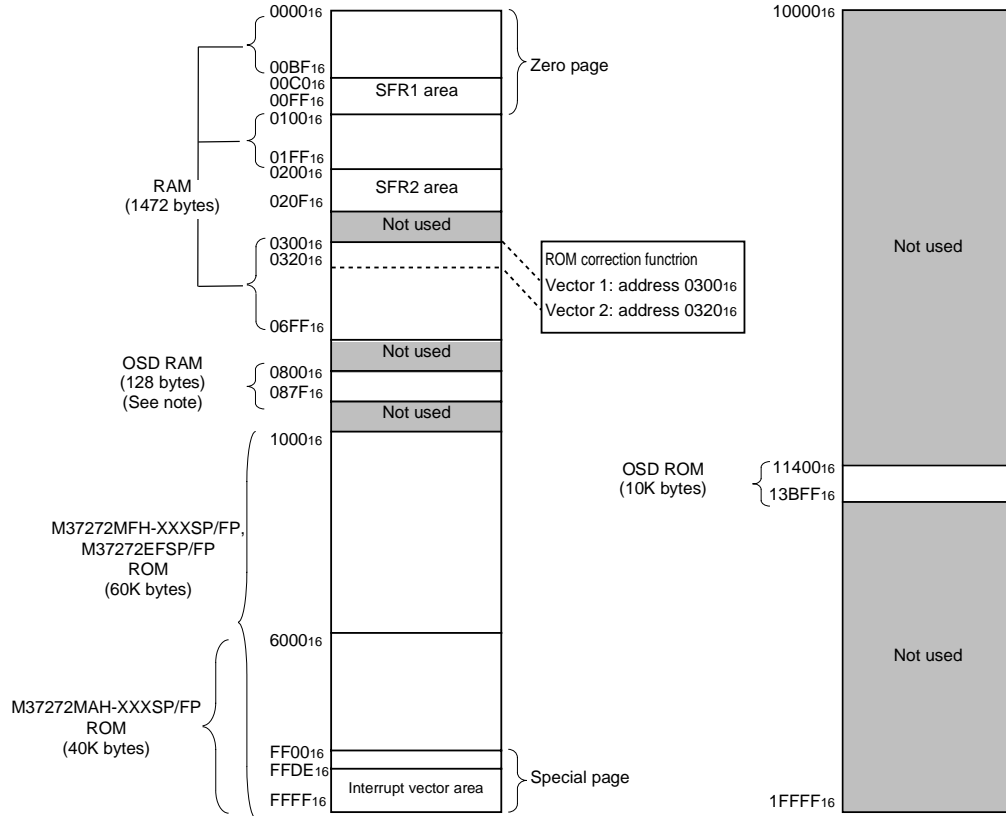

Note: Refer to Table 8.11.3 OSD RAM.

M37272M6H/M8H/MAH/MFH-XXXSP/FP M37272E8SP/FP, M37272EFSP/FP

SINGLE-CHIP 8-BIT CMOS MICROCOMPUTER with CLOSED CAPTION DECODER and ON-SCREEN DISPLAY CONTROLLER

Memory Map of Special Function Register (SFR)

Address	Register	Bit allocation								State immediately after reset								
		b7							b0	b7							b0	
C0 ¹⁶	Port P0 (P0)																	?
C1 ¹⁶	Port P0 direction register (D0)																	00 ¹⁶
C2 ¹⁶	Port P1 (P1)																	?
C3 ¹⁶	Port P1 direction register (D1)																	00 ¹⁶
C4 ¹⁶	Port P2 (P2)																	?
C5 ¹⁶	Port P2 direction register (D2)																	00 ¹⁶
C6 ¹⁶	Port P3 (P3)								P31 P30	0	0	0	0	0	0	?	?	?
C7 ¹⁶	Port P3 direction register (D3)		T3SC						P31C P30C P31D P30D									00 ¹⁶
C8 ¹⁶																		?
C9 ¹⁶																		?
CA ¹⁶	Port P5 (P5)																	?
CB ¹⁶	OSD port control register (PF)		PF7		PF5	PF4	PF3	PF2	0 0									00 ¹⁶
CC ¹⁶																		00 ¹⁶
CD ¹⁶																		?
CE ¹⁶	Caption data register 3 (CD3)		CDL27	CDL26	CDL25	CDL24	CDL23	CDL22	CDL21	CDL20								?
CF ¹⁶	Caption data register 4 (CD4)		CDH27	CDH26	CDH25	CDH24	CDH23	CDH22	CDH21	CDH20								?
D0 ¹⁶	OSD control register (OC)		0	OC6	OC5	OC4	OC3	OC2	OC1	OC0								00 ¹⁶
D1 ¹⁶	Horizontal position register (HP)			HP6	HP5	HP4	HP3	HP2	HP1	HP0								00 ¹⁶
D2 ¹⁶	Block control register 1 (BC1)		BC17	BC16	BC15	BC14	BC13	BC12	BC11	BC10								?
D3 ¹⁶	Block control register 2 (BC2)		BC27	BC26	BC25	BC24	BC23	BC22	BC21	BC20								?
D4 ¹⁶	Vertical position register 1 (VP1)		VP17	VP16	VP15	VP14	VP13	VP12	VP11	VP10								?
D5 ¹⁶	Vertical position register 2 (VP2)		VP27	VP26	VP25	VP24	VP23	VP22	VP21	VP20								?
D6 ¹⁶	Window register 1 (WN1)		WN17	WN16	WN15	WN14	WN13	WN12	WN11	WN10								?
D7 ¹⁶	Window register 2 (WN2)		WN27	WN26	WN25	WN24	WN23	WN22	WN21	WN20								?
D8 ¹⁶	I/O polarity control register (PC)		0	PC6	PC5	PC4	PC3	PC2	PC1	PC0								40 ¹⁶
D9 ¹⁶	Raster color register (RC)		RC7	0	0	RC4	RC3	RC2	RC1	RC0								00 ¹⁶
DA ¹⁶																		?
DB ¹⁶																		?
DC ¹⁶	Interrupt input polarity control register (RE)							INT3	INT2	INT1								00 ¹⁶
DD ¹⁶																		00 ¹⁶
DE ¹⁶																		00 ¹⁶
DF ¹⁶																		00 ¹⁶ (See note 1)

Notes 1: This is only M37272MAH/MFH-XXXSP/FP, M37272EFSP/FP.

2: As for M37272M6H/M8H-XXXSP/FP and M37272E8SP/FP, the reset value is ? (indeterminate).

M37272M6H/M8H/MAH/MFH-XXXSP/FP M37272E8SP/FP, M37272EFSP/FP

SINGLE-CHIP 8-BIT CMOS MICROCOMPUTER with CLOSED CAPTION DECODER
and ON-SCREEN DISPLAY CONTROLLER

■ SFR1 Area (addresses E0₁₆ to FF₁₆)

<Bit allocation>

: } Function bit
Name : }

: No function bit

0 : Fix this bit to "0"
(do not write "1")

1 : Fix this bit to "1"
(do not write "0")

<State immediately after reset>

0 : "0" immediately after reset

1 : "1" immediately after reset

? : Indeterminate immediately
after reset

Address	Register	Bit allocation								State immediately after reset										
		b7						b0						b7						b0
E0 ₁₆	Data slicer control register 1 (DSC1)	0	1	1	0	0	DSC12	DSC11	DSC10											00 ₁₆
E1 ₁₆	Data slicer control register 2 (DSC2)		0				DSC25	DSC24	DSC23				1							? 0 ? 0 ? ? 0 ?
E2 ₁₆	Caption data register 1 (CD1)	CDL17	CDL16	CDL15	CDL14	CDL13	CDL12	CDL11	CDL10										00 ₁₆	
E3 ₁₆	Caption data register 2 (CD2)	CDH17	CDH16	CDH15	CDH14	CDH13	CDH12	CDH11	CDH10										00 ₁₆	
E4 ₁₆	Clock run-in detect register (CRD)	CRD7	CRD6	CRD5	CRD4	CRD3													00 ₁₆	
E5 ₁₆	Data clock position register (DPS)	DPS7	DPS6	DPS5	DPS4	DPS3	0	1	0										09 ₁₆	
E6 ₁₆	Caption position register (CPS)	CPS7	CPS6	CPS5	CPS4	CPS3	CPS2	CPS1	CPS0										0 0 ? 0 0 0 0 0	
E7 ₁₆	Data slicer test register 2																		00 ₁₆	
E8 ₁₆	Data slicer test register 1																		00 ₁₆	
E9 ₁₆	Synchronous signal counter register			HC5	HC4	HC3	HC2	HC1	HC0										00 ₁₆	
EA ₁₆	Serial I/O register (SIO)																		?	
EB ₁₆	Serial I/O mode register (SM)	0	SM6	SM5	0	SM3	SM2	SM1	SM0										00 ₁₆	
EC ₁₆	A-D control register 1 (AD1)				ADC14		ADC12	ADC11	ADC10										0 0 0 ? 0 0 0 0	
ED ₁₆	A-D control register 2 (AD2)			ADC25	ADC24	ADC23	ADC22	ADC21	ADC20										00 ₁₆	
EE ₁₆	Timer 5 (T5)																		07 ₁₆	
EF ₁₆	Timer 6 (T6)																		FF ₁₆	
F0 ₁₆	Timer 1 (T1)																		FF ₁₆	
F1 ₁₆	Timer 2 (T2)																		07 ₁₆	
F2 ₁₆	Timer 3 (T3)																		FF ₁₆	
F3 ₁₆	Timer 4 (T4)																		07 ₁₆	
F4 ₁₆	Timer mode register 1 (TM1)	TM17	TM16	TM15	TM14	TM13	TM12	TM11	TM10										00 ₁₆	
F5 ₁₆	Timer mode register 2 (TM2)	TM27	TM26	TM25	TM24	TM23	TM22	TM21	TM20										00 ₁₆	
F6 ₁₆	I ² C data shift register (S0)	D7	D6	D5	D4	D3	D2	D1	D0										?	
F7 ₁₆	I ² C address register (S0D)	SAD6	SAD5	SAD4	SAD3	SAD2	SAD1	SAD0	RBW										00 ₁₆	
F8 ₁₆	I ² C status register (S1)	MST	TRX	BB	PIN	AL	AAS	AD0	LRB										0 0 0 1 0 0 0 ?	
F9 ₁₆	I ² C control register (S1D)	BSEL1	BSEL0	¹⁰ BIT SAD	ALS	ESO	BC2	BC1	BC0										00 ₁₆	
FA ₁₆	I ² C clock control register (S2)	ACK	ACK BIT	FAST MODE	CCR4	CCR3	CCR2	CCR1	CCR0										00 ₁₆	
FB ₁₆	CPU mode register (CPUM)	CM7	CM6	CM5	1	1	CM2	0	0										3C ₁₆	
FC ₁₆	Interrupt request register 1 (IREQ1)		IN3R	VSCR	OSDR	TM4R	TM3R	TM2R	TM1R										00 ₁₆	
FD ₁₆	Interrupt request register 2 (IREQ2)	0	TM56R	RICR	IN2R	CKR	S1R	DSR	IN1R										00 ₁₆	
FE ₁₆	Interrupt control register 1 (ICON1)		IN3E	VSCOE	OSDE	TM4E	TM3E	TM2E	TM1E										00 ₁₆	
FF ₁₆	Interrupt control register 2 (ICON2)	TM56C	TM56E	IICE	IN2E	CKE	S1E	DSE	IN1E										00 ₁₆	

M37272M6H/M8H/MAH/MFH-XXXSP/FP M37272E8SP/FP, M37272EFSP/FP

SINGLE-CHIP 8-BIT CMOS MICROCOMPUTER with CLOSED CAPTION DECODER
and ON-SCREEN DISPLAY CONTROLLER

■ SFR2 Area (addresses 200₁₆ to 20F₁₆)

<Bit allocation>

- : } Function bit
- Name : }
- : No function bit
- 0 : Fix this bit to "0"
(do not write "1")
- 1 : Fix this bit to "1"
(do not write "0")

<State immediately after reset>

- 0 : "0" immediately after reset
- 1 : "1" immediately after reset
- ? : Indeterminate immediately after reset

Address	Register	Bit allocation								State immediately after reset							
		b7						b0	b7	b7						b0	
200 ₁₆	PWM0 register (PWM0)																?
201 ₁₆	PWM1 register (PWM1)																?
202 ₁₆	PWM2 register (PWM2)																?
203 ₁₆	PWM3 register (PWM3)																?
204 ₁₆	PWM4 register (PWM4)																?
205 ₁₆	PWM5 register (PWM5)																?
206 ₁₆		00 ₁₆								?							
207 ₁₆		00 ₁₆								?							
208 ₁₆	PWM mode register 1 (PM1)						PM13								PM10		?
209 ₁₆	PWM mode register 2 (PM2)	0	0		PM25	PM24	PM23	PM22	PM21						PM20		0
20A ₁₆	ROM correction address 1 (high-order)																00 ₁₆
20B ₁₆	ROM correction address 1 (low-order)																00 ₁₆
20C ₁₆	ROM correction address 2 (high-order)																00 ₁₆
20D ₁₆	ROM correction address 2 (low-order)																00 ₁₆
20E ₁₆	ROM correction enable register (RCR)														RC1	RC0	00 ₁₆
20F ₁₆																	?

M37272M6H/M8H/MAH/MFH-XXXSP/FP
M37272E8SP/FP, M37272EFSP/FP

SINGLE-CHIP 8-BIT CMOS MICROCOMPUTER with CLOSED CAPTION DECODER
 and ON-SCREEN DISPLAY CONTROLLER

**Internal State of Processor Status Register and
 Program Counter at Reset**

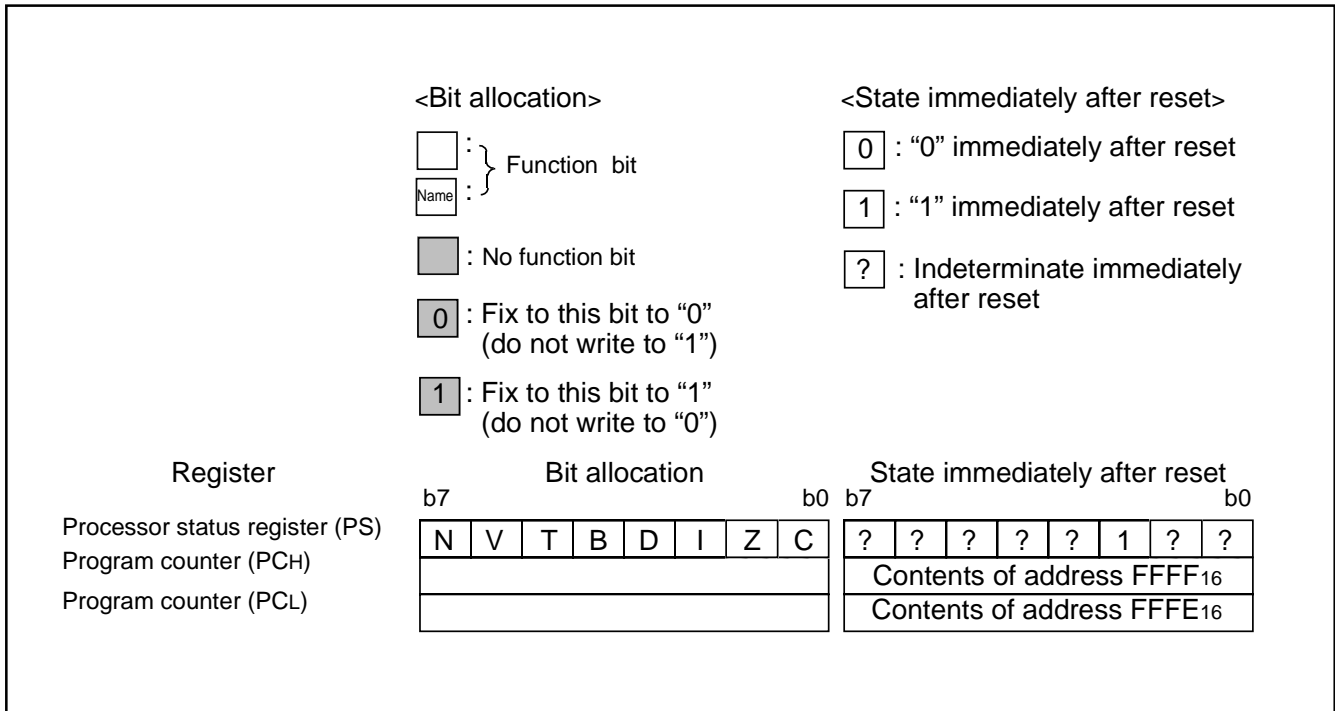

M37272M6H/M8H/MAH/MFH-XXXSP/FP M37272E8SP/FP, M37272EFSP/FP

SINGLE-CHIP 8-BIT CMOS MICROCOMPUTER with CLOSED CAPTION DECODER
and ON-SCREEN DISPLAY CONTROLLER

Structure of Register

The figure of each register structure describes its functions, contents at reset, and attributes as follows:

<Example>

CPU Mode Register

b7 b6 b5 b4 b3 b2 b1 b0

1 1 0 0

Bit position: CPU mode register (CPUM) (CM) [Address 00FB16]

Bit attributes (Note 2): Values immediately after reset release (Note 1)

B	Name	Functions	After reset release	R:W
0, 1	Processor mode bits (CM0, CM1)	b1 b0 0 0: Single-chip mode 0 1: } Not available 1 0: } 1 1: }	0	R:W
2	Stack page selection bit (See note) (CM2)	0: 0 page 1: 1 page	1	R:W
3, 4	Fix these bits to "1."		1	R:W
5	Nothing is assigned. This bit is write disable bit. When this bit is read out, the value is "1."		1	R:W
6, 7	Clock switch bits (CM6, CM7)	b7 b6 0 0: f(XIN) = 8 MHz 0 1: f(XIN) = 12 MHz 1 0: f(XIN) = 16 MHz 1 1: Do not set	0	R:W

■ : Bit in which nothing is assigned

Notes 1: Values immediately after reset release
 0 "0" after reset release
 1 "1" after reset release
 Indeterminate.....Indeterminate after reset release

Notes 2: Bit attributes.....The attributes of control register bits are classified into 3 types : read-only, write-only and read and write. In the figure, these attributes are represented as follows :

R.....Read
 RRead enabled
 -Read disabled

W.....Write
 WWrite enabled
 -Write disabled
 * "0" can be set by software, but "1" cannot be set.

M37272M6H/M8H/MAH/MFH-XXXSP/FP
M37272E8SP/FP, M37272EFSP/FP

SINGLE-CHIP 8-BIT CMOS MICROCOMPUTER with CLOSED CAPTION DECODER
 and ON-SCREEN DISPLAY CONTROLLER

Address 00C1₁₆, 00C3₁₆, 00C5₁₆

Port Pi Direction Register

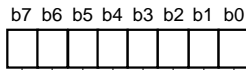

Port Pi direction register (PiD) (i=0,1,2) [Addresses 00C1₁₆, 00C3₁₆, 00C5₁₆]

B	Name	Functions	After reset	R	W
0	Port Pi direction register	0 : Port Pi ₀ input mode 1 : Port Pi ₀ output mode	0	R	W
1		0 : Port Pi ₁ input mode 1 : Port Pi ₁ output mode	0	R	W
2		0 : Port Pi ₂ input mode 1 : Port Pi ₂ output mode	0	R	W
3		0 : Port Pi ₃ input mode 1 : Port Pi ₃ output mode	0	R	W
4		0 : Port Pi ₄ input mode 1 : Port Pi ₄ output mode	0	R	W
5		0 : Port Pi ₅ input mode 1 : Port Pi ₅ output mode	0	R	W
6		0 : Port Pi ₆ input mode 1 : Port Pi ₆ output mode	0	R	W
7		0 : Port Pi ₇ input mode 1 : Port Pi ₇ output mode	0	R	W

Address 00C7₁₆

Port P3 Direction Register

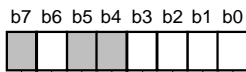

Port P3 direction register (P3D) [Address 00C7₁₆]

B	Name	Functions	After reset	R	W
0	Port P3 direction register	0 : Port P3 ₀ input mode 1 : Port P3 ₀ output mode	0	R	W
1		0 : Port P3 ₁ input mode 1 : Port P3 ₁ output mode	0	R	W
2	Port P3 ₀ output structure selection bit (P30C)	0 : CMOS output 1 : N-channel open-drain output	0	R	W
3	Port P3 ₁ output structure selection bit (P30C)	0 : CMOS output 1 : N-channel open-drain output	0	R	W
4, 5, 7	Nothing is assigned. These bits are write disable bits. When these bits are read out, the values are 0.		0	R	
6	Timer 3 count source selection bit (T3SC)	Refer to Timer section.	0	R	W

M37272M6H/M8H/MAH/MFH-XXXSP/FP
M37272E8SP/FP, M37272EFSP/FP

SINGLE-CHIP 8-BIT CMOS MICROCOMPUTER with CLOSED CAPTION DECODER
 and ON-SCREEN DISPLAY CONTROLLER

Address 00CB₁₆

OSD Port Control Register

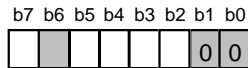

OSD port control register (PF) [Address 00CB₁₆]

B	Name	Functions	After reset	R;W
0, 1	Fix these bits to 0.		0	R;W
2	Port P5 ₂ output signal selection bit (PF2)	0 : R signal output 1 : Port P5 ₂ output	0	R;W
3	Port P5 ₃ output signal selection bit (PF3)	0 : G signal output 1 : Port P5 ₃ output	0	R;W
4	Port P5 ₄ output signal selection bit (PF4)	0 : B signal output 1 : Port P5 ₄ output	0	R;W
5	Port P5 ₅ output signal selection bit (PF5)	0 : OUT1 signal output 1 : Port P5 ₃ output	0	R;W
6	Nothing is assigned. This bit is write disable bit. When this bit is read out, the value is 0.		0	R;W
7	Port P1 ₀ output signal selection bit (PF7)	0 : Port P1 ₀ output 1 : OUT2 signal output	0	R;W

Address 00D0₁₆

OSD Control Register

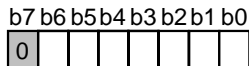

OSD control register (OC) [Address 00D0₁₆]

B	Name	Functions	After reset	R;W
0	OSD control bit (OC0) (See note)	0 : All-blocks display off 1 : All-blocks display on	0	R;W
1	Automatic solid space control bit (OC1)	0 : OFF 1 : ON	0	R;W
2	Window control bit (OC2)	0 : OFF 1 : ON	0	R;W
3	CC mode clock selection bit (OC3)	0 : Data slicer clock 1 : Clock from OSC1 pin	0	R;W
4	OSD mode clock selection bit (OC4)	0 : Data slicer clock 1 : Clock from OSC1 pin	0	R;W
5, 6	OSC1 clock selection bit (OC5, OC6)	^{b6 b5} 0 0: 32 kHz oscillating 0 1: Do not set. 1 0: LC oscillating, Ceramic oscillating 1 1: Do not set.	0	R;W
7	Fix this bit to 0.		0	R;W

Note: Even this bit is switched during display, the display screen remains unchanged until a rising (falling) of the next V SYNC.

M37272M6H/M8H/MAH/MFH-XXXSP/FP M37272E8SP/FP, M37272EFSP/FP

SINGLE-CHIP 8-BIT CMOS MICROCOMPUTER with CLOSED CAPTION DECODER
and ON-SCREEN DISPLAY CONTROLLER

Address 00D1₁₆

Horizontal Position Register

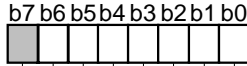

Horizontal position register (HP) [Address 00D1₁₆]

B	Name	Functions	After reset	R;W
0 to 6	Horizontal display start position control bits (HP0 to HP6)	Horizontal display start positions 128 steps (00 ₁₆ to 7F ₁₆) (1 step is 4T _{osc})	0	R;W
7	Nothing is assigned. This bit is a write disable bit. When this bit is read out, the value is "0."		0	R;—

Note: The setting value synchronizes with the V SYNC.

Address 00D2₁₆, 00D3₁₆

Block Control register i

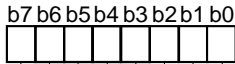

Block control register i (BCi) (i=1, 2) [Addresses 00D2₁₆ and 00D3₁₆]

B	Name	Functions	After reset	R;W
0, 1	Display mode selection bits (BCi0, BCi1) (See note 1)	b1 b0 0 0: Display OFF 0 1: CC mode 1 0: OSD mode (Border OFF) 1 1: OSD mode (Border ON)	Indeterminate	R;W
2, 3	Dot size selection bits (BCi2, BCi3)	b4 b3 b2 Pre-divide Ratio Dot Size 0 0 0 1Tc X 1/2H 0 0 1 1Tc X 1H 0 1 0 2Tc X 2H 0 1 1 3Tc X 3H x 2	Indeterminate	R;W
4	Pre-divide ratio selection bit (BCi4)	b4 b3 b2 Pre-divide Ratio Dot Size 1 0 0 1Tc X 1/2H 1 0 1 1Tc X 1H 1 1 0 2Tc X 2H 1 1 1 3Tc X 3H x 3	Indeterminate	R;W
5	OUT1/OUT2 output control bit (BCi5) (See note 1)	0: OUT1 output control 1: OUT2 output control	Indeterminate	R;W
6	Vertical display start position control bit (BCi6)	BC16: Block 1 BC26: Block 1	Indeterminate	R;W
7	Window top/bottom boundary control bit (BCi7)	BC17: Window top boundary BC27: Window bottom boundary	Indeterminate	R;W

Notes 1: Bit RA3 of OSD RAM controls OUT1 output when bit 5 is "0."
Bit RA3 of OSD RAM controls OUT2 output when bit 5 is "1."
2: Tc is OSD clock cycle divided in pre-divide circuit.
3: H is HSYNC.

M37272M6H/M8H/MAH/MFH-XXXSP/FP M37272E8SP/FP, M37272EFSP/FP

SINGLE-CHIP 8-BIT CMOS MICROCOMPUTER with CLOSED CAPTION DECODER
and ON-SCREEN DISPLAY CONTROLLER

Address 00D4₁₆, 00D5₁₆

Vertical Position Register i

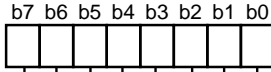

Vertical position register i (VPI) (i = 1 and 2) [Addresses 00D4₁₆, 00D5₁₆]

B	Name	Functions	After reset	R	W
0 to 7	Vertical display start position control bits (VPI0 to VPI7) (See note)	Vertical display start position = $T_H \times (BCi6 \times 16^2 + n)$ (n: setting value, T_H : H _{SYNC} cycle, BCi6: bit 6 of block control register i)	Indeterminate	R	W

Note: Set values except 00₁₆ to VPI when BCi6 is 0.

Address 00D6₁₆

Window Register 1

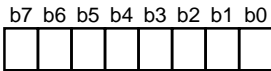

Window register 1 (WN1) [Address 00D6₁₆]

B	Name	Functions	After reset	R	W
0 to 7	Window top boundary control bits (WN10 to WN17)	Window top border position = $T_H \times (BC17 \times 16^2 + n)$ (n: setting value, T_H : H _{SYNC} cycle, BC17: bit 7 of block control register 1)	Indeterminate	R	W

Notes 1: Set values except 00₁₆ to WN1 when BC17 is 0.
2: Set values fit for the following condition: WN1 < WN2.

Address 00D7₁₆

Window Register 2

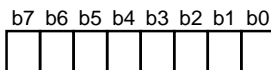

Window register 2 (WN2) [Address 00D7₁₆]

B	Name	Functions	After reset	R	W
0 to 7	Window bottom boundary control bits (WN20 to WN27)	Window bottom border position = $T_H \times (BC27 \times 16^2 + n)$ (n: setting value, T_H : H _{SYNC} cycle, BC27: bit 7 of block control register 2)	Indeterminate	R	W

Note: Set values fit for the following condition: WN1 < WN2.

M37272M6H/M8H/MAH/MFH-XXXSP/FP
M37272E8SP/FP, M37272EFSP/FP

SINGLE-CHIP 8-BIT CMOS MICROCOMPUTER with CLOSED CAPTION DECODER
 and ON-SCREEN DISPLAY CONTROLLER

Address 00D8₁₆

I/O Polarity Control Register

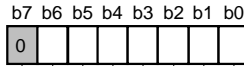

I/O polarity control register (PC) [Address 00D8₁₆]

B	Name	Functions	After reset	R	W
0	H _{SYNC} input polarity switch bit (PC0)	0 : Positive polarity input 1 : Negative polarity input	0	R	W
1	V _{SYNC} input polarity switch bit (PC1)	0 : Positive polarity input 1 : Negative polarity input	0	R	W
2	R, G, B output polarity switch bit (PC2)	0 : Positive polarity output 1 : Negative polarity output	0	R	W
3	OUT1 output polarity switch bit (PC3)	0 : Positive polarity output 1 : Negative polarity output	0	R	W
4	OUT2 output polarity switch bit (PC4)	0 : Positive polarity output 1 : Negative polarity output	0	R	W
5	Display dot line selection bit (PC5) (See note)	0 : at even field at odd field 1 : at even field at odd field	0	R	W
6	Field determination flag (PC6)	0 : Even field 1 : Odd field	1	R	—
7	Fix this bit to "0."		0	R	W

Note: Refer to the corresponding figure (8.11.14).

Address 00D9₁₆

Raster Color Register

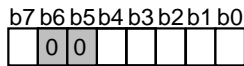

Raster color register (RC) [Address 00D9₁₆]

B	Name	Functions	After reset	R	W
0	Raster color R control bit (RC0)	0 : No output 1 : Output	0	R	W
1	Raster color G control bit (RC1)	0 : No output 1 : Output	0	R	W
2	Raster color B control bit (RC2)	0 : No output 1 : Output	0	R	W
3	Raster color OUT1 control bit (RC3)	0 : No output 1 : Output	0	R	W
4	Raster color OUT2 control bit (RC4)	0 : No output 1 : Output	0	R	W
5, 6	Fix these bits to "0."		0	R	W
7	Port function selection bit (RC7)	0 : OSC1/X _{CIN} , OSC2/X _{COUT} 1 : P2 ₆ , P2 ₇	0	R	W

Note: Either OSD clock source or 32 kHz oscillating clock is selected by bits 5 and 6 of the OSD control register.

M37272M6H/M8H/MAH/MFH-XXXSP/FP M37272E8SP/FP, M37272EFSP/FP

SINGLE-CHIP 8-BIT CMOS MICROCOMPUTER with CLOSED CAPTION DECODER
and ON-SCREEN DISPLAY CONTROLLER

Address 00DC₁₆

Interrupt Input Polarity Register

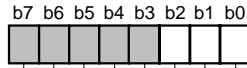

Interrupt input polarity register (RE) [Address 00DC₁₆]

B	Name	Functions	After reset	R	W
0	INT1 polarity switch bit (INT1)	0 : Positive polarity 1 : Negative polarity	0	R	W
4	INT2 polarity switch bit (INT2)	0 : Positive polarity 1 : Negative polarity	0	R	W
5	INT3 polarity switch bit (INT3)	0 : Positive polarity 1 : Negative polarity	0	R	W
4 to 7	Nothing is assigned. These bits are write disable bits. When these bits are read out, the values are "0."		0	R	—

Address 00E0₁₆

Data Slicer Control Register 1

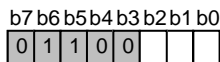

Data slicer control register 1(DSC1) [Address 00E0₁₆]

B	Name	Functions	After reset	R	W
0	Data slicer and timing signal generating circuit control bit (DSC10)	0: Stopped 1: Operating	0	R	W
1	Selection bit of data slice reference voltage generating field (DSC11)	0: F2 1: F1	0	R	W
2	Reference clock source selection bit (DSC12)	0: Video signal 1: HSYNC signal	0	R	W
3, 4	Fix these bits to "0."		0	R	W
5, 6	Fix these bits to "1."		0	R	W
7	Fix this bit to "0."		0	R	W

Definition of fields 1 (F1) and 2 (F2)

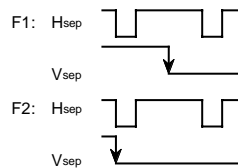

M37272M6H/M8H/MAH/MFH-XXXSP/FP M37272E8SP/FP, M37272EFSP/FP

SINGLE-CHIP 8-BIT CMOS MICROCOMPUTER with CLOSED CAPTION DECODER
and ON-SCREEN DISPLAY CONTROLLER

Address 00E1₁₆

Data Slicer Control Register 2

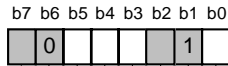

Data slicer control register 2 (DSC2) [Address 00E1₁₆]

B	Name	Functions	After reset	R	W
0	Caption data latch completion flag 1 (DSC20)	0: Data is not latched yet and a clock-run-in is not determined. 1: Data is latched and a clock-run-in is determined.	Indeterminate	R	—
1	Fix this bit to "1."		0	R	W
2	Test bit	Read-only	Indeterminate	R	—
3	Field determination flag(DSC23)	0: F2 1: F1	Indeterminate	R	—
4	Vertical synchronous signal (V _{sep}) generating method selection bit (DSC24)	0: Method (1) 1: Method (2)	0	R	W
5	V-pulse shape determination flag (DSC25)	0: Match 1: Mismatch	Indeterminate	R	—
6	Fix this bit to "0."		0	R	W
7	Test bit	Read-only	Indeterminate	R	—

Definition of fields 1 (F1) and 2 (F2)

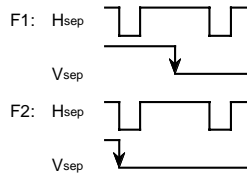

Address 00E4₁₆

Clock Run-in Detect Register

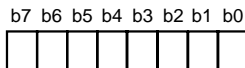

Clock run-in detect register (CRD) [Address 00E4₁₆]

B	Name	Functions	After reset	R	W
0 to 2	Test bits	Read-only	0	R	—
3 to 7	Clock run-in detection bit (CRD3 to CRD7)	Number of reference clocks to be counted in one clock run-in pulse period.	0	R	—

M37272M6H/M8H/MAH/MFH-XXXSP/FP M37272E8SP/FP, M37272EFSP/FP

SINGLE-CHIP 8-BIT CMOS MICROCOMPUTER with CLOSED CAPTION DECODER
and ON-SCREEN DISPLAY CONTROLLER

Address 00E5₁₆

Data Clock Position Register

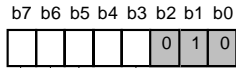

Data clock position register (DPS) [Address 00E5₁₆]

B	Name	Functions	After reset	R	W
0	Fix this bit to "0."		1	R	W
1	Fix this bit to "1."		0	R	W
2	Fix this bit to "0."		0	R	W
3	Data clock position set bits (DPS3 to DPS7)		1	R	W
4 to 7			0		

Address 00E6₁₆

Caption Position Register

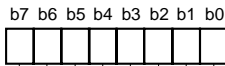

Caption Position Register (CPS) [Address 00E6₁₆]

B	Name	Functions	After reset	R	W
0 to 4	Caption position bits (CPS0 to CPS4)		0	R	W
5	Caption data latch completion flag 2 (CPS5)	0: Data is not latched yet and a clock-run-in is not determined. 1: Data is latched and a clock-run-in is determined.	Indeterminate	R	
6, 7	Slice line mode specification bits (in 1 field) (CPS6, CPS7)	Refer to the corresponding Table (Table 8.10.1).	0	R	W

Address 00E9₁₆

Sync Pulse Counter Register

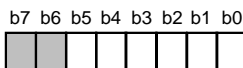

Sync pulse counter register (HC) [Address 00E9₁₆]

B	Name	Functions	After reset	R	W
0 to 4	Count value (HC0 to HC4)		0	R	
5	Count source (HC5)	0: Hsync signal 1: Composite sync signal	0	R	W
6, 7	Nothing is assigned. These bits are write disable bits. When these bits are read out, the values are 0.		0	R	

M37272M6H/M8H/MAH/MFH-XXXSP/FP M37272E8SP/FP, M37272EFSP/FP

SINGLE-CHIP 8-BIT CMOS MICROCOMPUTER with CLOSED CAPTION DECODER
and ON-SCREEN DISPLAY CONTROLLER

Address 00EB₁₆

Serial I/O Mode Register

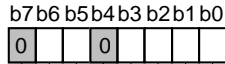

Serial I/O mode register (SM) [Address 00EB₁₆]

B	Name	Functions	After reset	R	W
0, 1	Internal synchronous clock selection bits (SM0, SM1)	b1 b0 0 0: f(XIN)/4 or f(XCIN)/4 0 1: f(XIN)/16 or f(XCIN)/16 1 0: f(XIN)/32 or f(XCIN)/32 1 1: f(XIN)/64 or f(XCIN)/64	0	R	W
2	Synchronous clock selection bit (SM2)	0: External clock 1: Internal clock	0	R	W
3	Port function selection bit (SM3)	0: P20, P21 1: SCLK, SOUT	0	R	W
4	Fix this bit to "0."		0	R	W
5	Transfer direction selection bit (SM5)	0: LSB first 1: MSB first	0	R	W
6	Transfer clock input pin selection bit (SM6)	0: Input signal from SIN pin 1: Input signal from SOUT pin	0	R	W
7	Fix this bit to "0."		0	R	W

Address 00EC₁₆

A-D Control Register 1

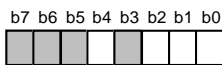

A-D control register 1 (AD1) [Address 00EC₁₆]

B	Name	Functions	After reset	R	W
0 to 2	Analog input pin selection bits (ADC10 to ADC12)	b2 b1 b0 0 0 0: AD1 0 0 1: AD2 0 1 0: AD3 0 1 1: AD4 1 0 0: AD5 1 0 1: AD6 1 1 0: } Do not set. 1 1 1: }	0	R	W
3	This bit is a write disable bit. When this bit is read out, the value is "0."		0	R	—
4	Storage bit of comparison result (ADC14)	0: Input voltage < reference voltage 1: Input voltage > reference voltage	Indeterminate	R	W
5 to 7	Nothing is assigned. These bits are write disable bits. When these bits are read out, the values are "0."		0	R	—

M37272M6H/M8H/MAH/MFH-XXXSP/FP
M37272E8SP/FP, M37272EFSP/FP

SINGLE-CHIP 8-BIT CMOS MICROCOMPUTER with CLOSED CAPTION DECODER
 and ON-SCREEN DISPLAY CONTROLLER

Address 00ED₁₆

A-D Control Register 2

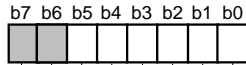

A-D control register 2 (AD2) [Address 00ED₁₆]

B	Name	Functions	After reset	R	W
0 to 5	D-A converter set bits (ADC20 to ADC25)	b5 b4 b3 b2 b1 b0 0 0 0 0 0 0 : 1/128V _{cc} 0 0 0 0 0 1 : 3/128V _{cc} 0 0 0 0 1 0 : 5/128V _{cc} ⋮ 1 1 1 1 0 1 : 123/128V _{cc} 1 1 1 1 1 0 : 125/128V _{cc} 1 1 1 1 1 1 : 127/128V _{cc}	0	R	W
6, 7	Nothing is assigned. These bits are write disable bits. When these bits are read out, the values are 0.		0	R	

Address 00F4₁₆

Timer Mode Register 1

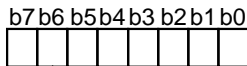

Timer mode register 1 (TM1) [Address 00F4₁₆]

B	Name	Functions	After reset	R	W
0	Timer 1 count source selection bit 1 (TM10)	0: f(X _{IN})/16 or f(X _{CIN})/16 (See note) 1: Count source selected by bit 5 of TM1	0	R	W
1	Timer 2 count source selection bit 1 (TM11)	0: Count source selected by bit 4 of TM1 1: External clock from TIM2 pin	0	R	W
2	Timer 1 count stop bit (TM12)	0: Count start 1: Count stop	0	R	W
3	Timer 2 count stop bit (TM13)	0: Count start 1: Count stop	0	R	W
4	Timer 2 count source selection bit 2 (TM14)	0: f(X _{IN})/16 or f(X _{CIN})/16 (See note) 1: Timer 1 overflow	0	R	W
5	Timer 1 count source selection bit 2 (TM15)	0: f(X _{IN})/4096 or f(X _{CIN})/4096 (See note) 1: External clock from TIM2 pin	0	R	W
6	Timer 5 count source selection bit 2 (TM16)	0: Timer 2 overflow 1: Timer 4 overflow	0	R	W
7	Timer 6 internal count source selection bit (TM17)	0: f(X _{IN})/16 or f(X _{CIN})/16 (See note) 1: Timer 5 overflow	0	R	W

Note: Either f(X_{IN}) or f(X_{CIN}) is selected by bit 7 of the CPU mode register.

M37272M6H/M8H/MAH/MFH-XXXSP/FP M37272E8SP/FP, M37272EFSP/FP

SINGLE-CHIP 8-BIT CMOS MICROCOMPUTER with CLOSED CAPTION DECODER
and ON-SCREEN DISPLAY CONTROLLER

Address 00F5₁₆

Timer Mode Register 2

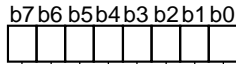

Timer mode register 2 (TM2) [Address 00F5₁₆]

B	Name	Functions	After reset	R	W
0	Timer 3 count source selection bit (TM20)	(b6 at address 00C7 ₁₆) ↓ b0 0 0 : f(X _{IN})/16 or f(X _{CIN})/16 (See note) 0 1 : f(X _{CIN}) 1 0 : } 1 1 : } External clock from TIM3 pin	0	R	W
1, 4	Timer 4 count source selection bits (TM21, TM24)	b4 b1 0 0 : Timer 3 overflow signal 0 1 : f(X _{IN})/16 or f(X _{CIN})/16 (See note) 1 0 : f(X _{IN})/2 or f(X _{CIN})/2 (See note) 1 1 : f(X _{CIN})	0	R	W
2	Timer 3 count stop bit (TM22)	0: Count start 1: Count stop	0	R	W
3	Timer 4 count stop bit (TM23)	0: Count start 1: Count stop	0	R	W
5	Timer 5 count stop bit (TM25)	0: Count start 1: Count stop	0	R	W
6	Timer 6 count stop bit (TM26)	0: Count start 1: Count stop	0	R	W
7	Timer 5 count source selection bit 1 (TM27)	0: f(X _{IN})/16 or f(X _{CIN})/16 (See note) 1: Count source selected by bit 6 of TM1	0	R	W

Note: Either f(X_{IN}) or f(X_{CIN}) is selected by bit 7 of the CPU mode register.

Address 00F6₁₆

I²C Data Shift Register

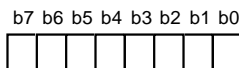

I²C data shift register1(S0) [Address 00F6₁₆]

B	Name	Functions	After reset	R	W
0 to 7	D0 to D7	This is an 8-bit shift register to store receive data and write transmit data.	Indeterminate	R	W

Note: To write data into the I²C data shift register after setting the MST bit to "0" (slave mode), keep an interval of 8 machine cycles or more.

M37272M6H/M8H/MAH/MFH-XXXSP/FP
M37272E8SP/FP, M37272EFSP/FP

SINGLE-CHIP 8-BIT CMOS MICROCOMPUTER with CLOSED CAPTION DECODER
 and ON-SCREEN DISPLAY CONTROLLER

Address 00F7₁₆

I²C Address Register

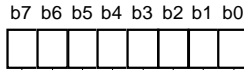

I²C address register (S0D) [Address 00F7₁₆]

B	Name	Functions	After reset	R : W
0	Read/write bit (RBW)	<Only in 10-bit addressing (in slave) mode> The last significant bit of address data is compared. 0: Wait the first byte of slave address after START condition (read state) 1: Wait the first byte of slave address after RESTART condition (write state)	0	R : —
1 to 7	Slave address (SAD0 to SAD6)	<In both modes> The address data is compared.	0	R : W

Address 00F8₁₆

I²C Status Register

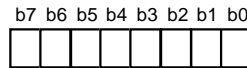

I²C status register (S1) [Address 00F8₁₆]

B	Name	Functions	After reset	R : W
0	Last receive bit (LRB) (See note)	0 : Last bit = "0" 1 : Last bit = "1" (See note)	Indeterminate	R : —
1	General call detecting flag (AD0) (See note)	0 : No general call detected 1 : General call detected (See note)	0	R : —
2	Slave address comparison flag (AAS) (See note)	0 : Address mismatch 1 : Address match (See note)	0	R : —
3	Arbitration lost detecting flag (AL) (See note)	0 : Not detected 1 : Detected (See note)	0	R : —
4	I ² C-BUS interface interrupt request bit (PIN)	0 : Interrupt request issued 1 : No interrupt request issued	1	R : W
5	Bus busy flag (BB)	0 : Bus free 1 : Bus busy	0	R : W
6, 7	Communication mode specification bits (TRX, MST)	b7 b6 0 0 : Slave receive mode 0 1 : Slave transmit mode 1 0 : Master receive mode 1 1 : Master transmit mode	0	R : W

Note : These bits and flags can be read out, but cannot be written.

M37272M6H/M8H/MAH/MFH-XXXSP/FP M37272E8SP/FP, M37272EFSP/FP

SINGLE-CHIP 8-BIT CMOS MICROCOMPUTER with CLOSED CAPTION DECODER
and ON-SCREEN DISPLAY CONTROLLER

Address 00F9₁₆

I²C Control Register

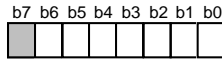

I²C control register (S1D address 00F9₁₆)

B	Name	Functions	After reset	R:W
0 to 2	Bit counter (Number of transmit/recieve bits) (BC0 to BC2)	b2 b1 b0 0 0 0: 8 0 0 1: 7 0 1 0: 6 0 1 1: 5 1 0 0: 4 1 0 1: 3 1 1 0: 2 1 1 1: 1	0	R:W
3	I ² C-BUS interface use enable bit (ESO)	0 : Disabled 1 : Enabled	0	R:W
4	Data format selection bit(ALS)	0 : Addressing mode 1 : Free data format	0	R:W
5	Addressing format selection bit (10BIT SAD)	0 : 7-bit addressing format 1 : 10-bit addressing format	0	R:W
6, 7	Connection control bits between I ² C-BUS interface and ports	b7 b6 Connection port (See note) 0 0 : None 0 1 : SCL1, SDA1 1 0 : SCL2, SDA2 1 1 : SCL1, SDA1 SCL2, SDA2	0	R:W

Note: When using ports P11-P14 as I²C-BUS interface, the output structure changes automatically from CMOS output to N-channel open-drain output.

Address 00FA₁₆

I²C Clock Control Register

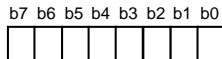

I²C clock control register (S2 : address 00FA₁₆)

B	Name	Functions	After reset	R:W																														
0 to 4	SCL frequency control bits (CCR0 to CCR4)	<table border="1"> <thead> <tr> <th>Setup value of CCR4-CCR0</th> <th>Standard clock mode</th> <th>High speed clock mode</th> </tr> </thead> <tbody> <tr> <td>00 to 02</td> <td>Setup disabled</td> <td>Setup disabled</td> </tr> <tr> <td>03</td> <td>Setup disabled</td> <td>333</td> </tr> <tr> <td>04</td> <td>Setup disabled</td> <td>250</td> </tr> <tr> <td>05</td> <td>100</td> <td>400 (See note)</td> </tr> <tr> <td>06</td> <td>83.3</td> <td>166</td> </tr> <tr> <td>⋮</td> <td>500/CCR value</td> <td>1000/CCR value</td> </tr> <tr> <td>1D</td> <td>17.2</td> <td>34.5</td> </tr> <tr> <td>1E</td> <td>16.6</td> <td>33.3</td> </tr> <tr> <td>1F</td> <td>16.1</td> <td>32.3</td> </tr> </tbody> </table> <p>(at φ = 4 MHz, unit : kHz)</p>	Setup value of CCR4-CCR0	Standard clock mode	High speed clock mode	00 to 02	Setup disabled	Setup disabled	03	Setup disabled	333	04	Setup disabled	250	05	100	400 (See note)	06	83.3	166	⋮	500/CCR value	1000/CCR value	1D	17.2	34.5	1E	16.6	33.3	1F	16.1	32.3	0	R:W
Setup value of CCR4-CCR0	Standard clock mode	High speed clock mode																																
00 to 02	Setup disabled	Setup disabled																																
03	Setup disabled	333																																
04	Setup disabled	250																																
05	100	400 (See note)																																
06	83.3	166																																
⋮	500/CCR value	1000/CCR value																																
1D	17.2	34.5																																
1E	16.6	33.3																																
1F	16.1	32.3																																
5	SCL mode specification bit (FAST MODE)	0: Standard clock mode 1: High-speed clock mode	0	R:W																														
6	ACK bit (ACK BIT)	0: ACK is returned. 1: ACK is not returned.	0	R:W																														
7	ACK clock bit (ACK)	0: No ACK clock 1: ACK clock	0	R:W																														

Note: At 4000kHz in the high-speed clock mode, the duty is as below .
"0" period : "1" period = 3 : 2
In the other cases, the duty is as below.
"0" period : "1" period = 1 : 1

M37272M6H/M8H/MAH/MFH-XXXSP/FP
M37272E8SP/FP, M37272EFSP/FP

SINGLE-CHIP 8-BIT CMOS MICROCOMPUTER with CLOSED CAPTION DECODER
 and ON-SCREEN DISPLAY CONTROLLER

Address 00FB₁₆

CPU Mode Register

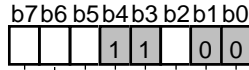

CPU mode register (CM) [Address 00FB₁₆]

B	Name	Functions	After reset	R	W
0, 1	Processor mode bits (CM0, CM1)	b1 b0 0 0: Single-chip mode 0 1: } 1 0: } Not available 1 1: }	0	R	W
2	Stack page selection bit (CM2) (See note)	0: 0 page 1: 1 page	1	R	W
3, 4	Fix these bits to 1.		1	R	W
5	XCOUT drivability selection bit (CM5)	0: LOW drive 1: HIGH drive	1	R	W
6	Main Clock (XIN—XOUT) stop bit (CM6)	0: Oscillating 1: Stopped	0	R	W
7	Internal system clock selection bit (CM7)	0: XIN—XOUT selected (high-speed mode) 1: XCIN—XCOUT selected (high-speed mode)	0	R	W

Note: This bit is set to 1 after the reset release.

Address 00FC₁₆

Interrupt Request Register 1

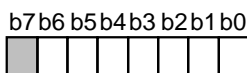

Interrupt request register 1 (IREQ1) [Address 00FC₁₆]

B	Name	Functions	After reset	R	W
0	Timer 1 interrupt request bit (TM1R)	0 : No interrupt request issued 1 : Interrupt request issued	0	R	*
1	Timer 2 interrupt request bit (TM2R)	0 : No interrupt request issued 1 : Interrupt request issued	0	R	*
2	Timer 3 interrupt request bit (TM3R)	0 : No interrupt request issued 1 : Interrupt request issued	0	R	*
3	Timer 4 interrupt request bit (TM4R)	0 : No interrupt request issued 1 : Interrupt request issued	0	R	*
4	OSD interrupt request bit (OSDR)	0 : No interrupt request issued 1 : Interrupt request issued	0	R	*
5	VSYNC interrupt request bit (VSCR)	0 : No interrupt request issued 1 : Interrupt request issued	0	R	*
6	INT3 external interrupt request bit (VSCR)	0 : No interrupt request issued 1 : Interrupt request issued	0	R	*
7	Nothing is assigned. This bit is a write disable bit. When this bit is read out, the value is "0."		0	R	—

*: "0" can be set by software, but "1" cannot be set.

M37272M6H/M8H/MAH/MFH-XXXSP/FP
M37272E8SP/FP, M37272EFSP/FP

SINGLE-CHIP 8-BIT CMOS MICROCOMPUTER with CLOSED CAPTION DECODER
 and ON-SCREEN DISPLAY CONTROLLER

Address 00FD₁₆

Interrupt Request Register 2

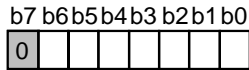

Interrupt request register 2 (IREQ2) [Address 00FD₁₆]

B	Name	Functions	After reset	R	W
0	INT1 external interrupt request bit (INIR)	0 : No interrupt request issued 1 : Interrupt request issued	0	R	*
1	Data slicer interrupt request bit (DSR)	0 : No interrupt request issued 1 : Interrupt request issued	0	R	*
2	Serial I/O interrupt request bit (S1R)	0 : No interrupt request issued 1 : Interrupt request issued	0	R	*
3	f(XIN)/4096 interrupt request bit (CKR)	0 : No interrupt request issued 1 : Interrupt request issued	0	R	*
4	INT2 external interrupt request bit (IN2R)	0 : No interrupt request issued 1 : Interrupt request issued	0	R	*
5	Multi-master I ² C-BUS interrupt request bit (IICR)	0 : No interrupt request issued 1 : Interrupt request issued	0	R	*
6	Timer 5 • 6 interrupt request bit (TM56R)	0 : No interrupt request issued 1 : Interrupt request issued	0	R	*
7	Fix this bit to "0."		0	R	W

*: "0" can be set by software, but "1" cannot be set.

Address 00FE₁₆

Interrupt Control Register 1

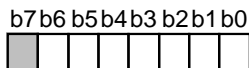

Interrupt control register 1 (ICON1) [Address 00FE₁₆]

B	Name	Functions	After reset	R	W
0	Timer 1 interrupt enable bit (TM1E)	0 : Interrupt disabled 1 : Interrupt enabled	0	R	W
1	Timer 2 interrupt enable bit (TM2E)	0 : Interrupt disabled 1 : Interrupt enabled	0	R	W
2	Timer 3 interrupt enable bit (TM3E)	0 : Interrupt disabled 1 : Interrupt enabled	0	R	W
3	Timer 4 interrupt enable bit (TM4E)	0 : Interrupt disabled 1 : Interrupt enabled	0	R	W
4	OSD interrupt enable bit (OSDE)	0 : Interrupt disabled 1 : Interrupt enabled	0	R	W
5	VSYNC interrupt enable bit (VSCE)	0 : Interrupt disabled 1 : Interrupt enabled	0	R	W
6	INT3 external interrupt enable bit (IN3E)	0 : Interrupt disabled 1 : Interrupt enabled	0	R	W
7	Nothing is assigned. This bit is a write disable bit. When this bit is read out, the value is "0."		0	R	—

M37272M6H/M8H/MAH/MFH-XXXSP/FP
M37272E8SP/FP, M37272EFSP/FP

SINGLE-CHIP 8-BIT CMOS MICROCOMPUTER with CLOSED CAPTION DECODER
 and ON-SCREEN DISPLAY CONTROLLER

Address 00FF₁₆

Interrupt Control Register 2

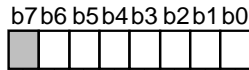

Interrupt control register 2 (ICON2) [Address 00FF₁₆]

B	Name	Functions	After reset	R	W
0	INT1 external interrupt enable bit (IN1E)	0 : Interrupt disabled 1 : Interrupt enabled	0	R	W
1	Data slicer interrupt enable bit (DSE)	0 : Interrupt disabled 1 : Interrupt enabled	0	R	W
2	Serial I/O interrupt enable bit (S1E)	0 : Interrupt disabled 1 : Interrupt enabled	0	R	W
3	f(XIN)/4096 interrupt enable bit (CKE)	0 : Interrupt disabled 1 : Interrupt enabled	0	R	W
4	INT2 external interrupt enable bit (IN2E)	0 : Interrupt disabled 1 : Interrupt enabled	0	R	W
5	Multi-master I ² C-BUS interface interrupt enable bit (IICE)	0 : Interrupt disabled 1 : Interrupt enabled	0	R	W
6	Timer 5 • 6 interrupt enable bit (TM56E)	0 : Interrupt disabled 1 : Interrupt enabled	0	R	W
7	Timer 5 • 6 interrupt switch bit (TM56C)	0 : Timer 5 1 : Timer 6	0	R	W

Address 0208₁₆

PWM Mode Register 1

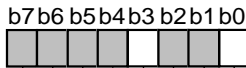

PWM mode register 1 (PM1) [Address 0208₁₆]

B	Name	Functions	After reset	R	W
0	PWM counts source selection bit (PM10)	0 : Count source supply 1 : Count source stop	0	R	W
1, 2	Nothing is assigned. These bits are write disable bits. When these bits are read out, the values are 0.		Indeterminate	R	
3	PWM output polarity selection bit (PM13)	0 : Positive polarity 1 : Negative polarity	0	R	W
4 to 7	Nothing is assigned. These bits are write disable bits. When these bits are read out, the values are 0.		Indeterminate	R	

M37272M6H/M8H/MAH/MFH-XXXSP/FP
M37272E8SP/FP, M37272EFSP/FP

SINGLE-CHIP 8-BIT CMOS MICROCOMPUTER with CLOSED CAPTION DECODER
 and ON-SCREEN DISPLAY CONTROLLER

Address 0209₁₆

PWM Mode Register 2

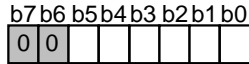

PWM mode register 2 (PM2) [Address 0209₁₆]

B	Name	Functions	After reset	R	W
0	P0 ₀ /PWM0 output selection bit (PM20)	0 : P0 ₀ output 1 : PWM0 output	0	R	W
1	P0 ₁ /PWM1 output selection bit (PM21)	0 : P0 ₁ output 1 : PWM1 output	0	R	W
2	P0 ₂ /PWM2 output selection bit (PM22)	0 : P0 ₂ output 1 : PWM2 output	0	R	W
3	P0 ₃ /PWM3 output selection bit (PM23)	0 : P0 ₃ output 1 : PWM3 output	0	R	W
4	P0 ₄ /PWM4 output selection bit (PM24)	0 : P0 ₄ output 1 : PWM4 output	0	R	W
5	P0 ₅ /PWM5 output selection bit (PW25)	0: P0 ₅ output 1: PWM5 output	0	R	W
6, 7	Fix these bits to 0.		0	R	W

Address 020E₁₆

ROM Correction Enable Register

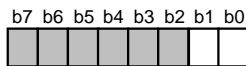

ROM correction enable register (RCR) [Address 020E₁₆]

B	Name	Functions	After reset	R	W
0	Vector 1 enable bit (RC0)	0: Disabled 1: Enabled	0	R	W
1	Vector 2 enable bit (RC1)	0: Disabled 1: Enabled	0	R	W
2 to 7	Nothing is assigned. These bits are write disable bits. When these bits are read out, the values are "0."		0	R	—

M37272M6H/M8H/MAH/MFH-XXXSP/FP M37272E8SP/FP, M37272EFSP/FP

SINGLE-CHIP 8-BIT CMOS MICROCOMPUTER with CLOSED CAPTION DECODER
and ON-SCREEN DISPLAY CONTROLLER

19. PACKAGE OUTLINE

42P4B

Plastic 42pin 600mil SDIP

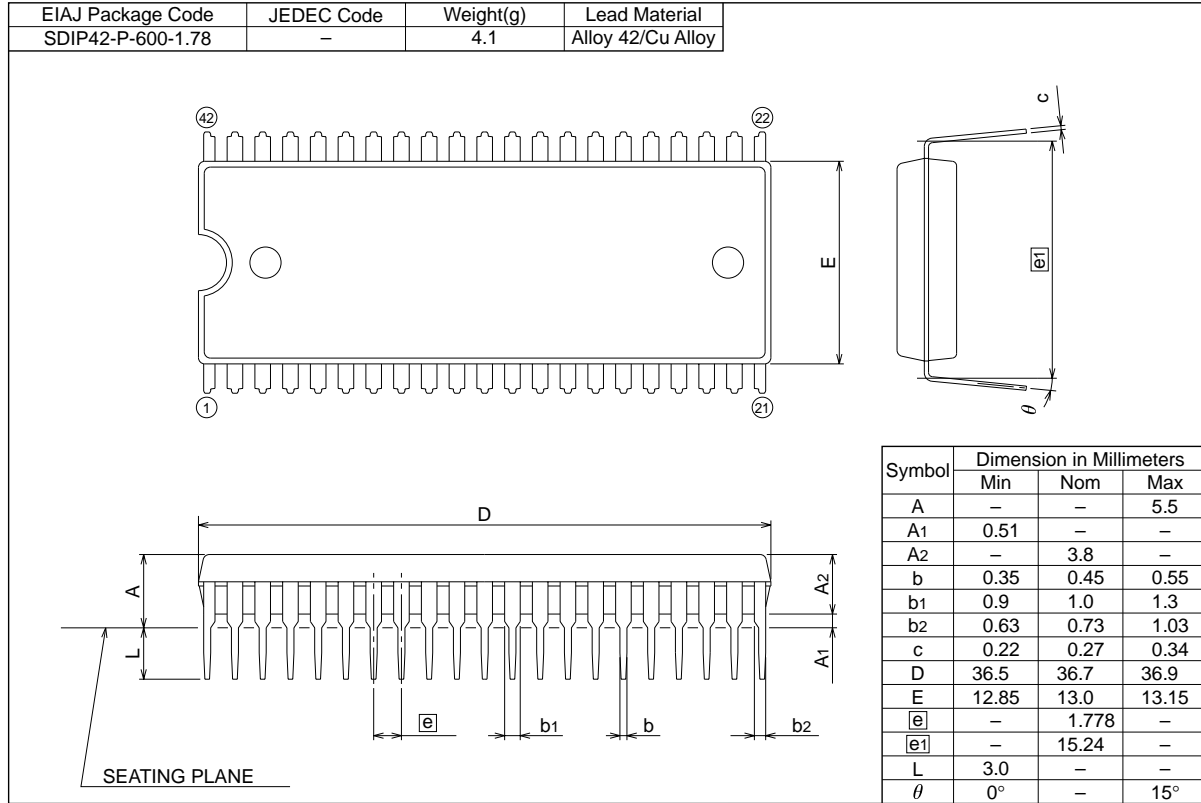

42P2R-A/E

Plastic 42pin 450mil SSOP

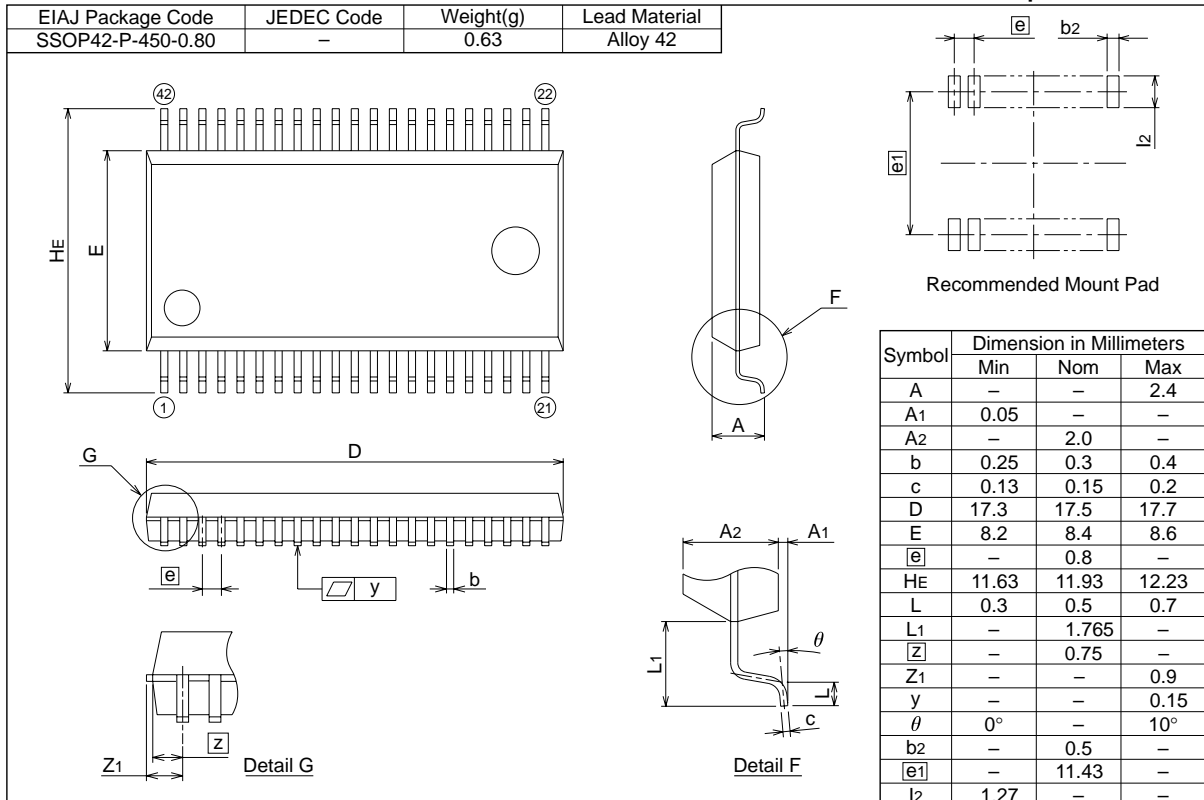

M37272M6H/M8H/MAH/MFH-XXXSP/FP
M37272E8SP/FP, M37272EFSP/FP

SINGLE-CHIP 8-BIT CMOS MICROCOMPUTER with CLOSED CAPTION DECODER
 and ON-SCREEN DISPLAY CONTROLLER

Renesas Technology Corp.

Nippon Bldg.,6-2,Otemachi 2-chome,Chiyoda-ku,Tokyo,100-0004 Japan

Keep safety first in your circuit designs!

- Mitsubishi Electric Corporation puts the maximum effort into making semiconductor products better and more reliable, but there is always the possibility that trouble may occur with them. Trouble with semiconductors may lead to personal injury, fire or property damage. Remember to give due consideration to safety when making your circuit designs, with appropriate measures such as (i) placement of substitutive, auxiliary circuits, (ii) use of non-flammable material or (iii) prevention against any malfunction or mishap.

Notes regarding these materials

- These materials are intended as a reference to assist our customers in the selection of the Mitsubishi semiconductor product best suited to the customer's application; they do not convey any license under any intellectual property rights, or any other rights, belonging to Mitsubishi Electric Corporation or a third party.
- Mitsubishi Electric Corporation assumes no responsibility for any damage, or infringement of any third-party's rights, originating in the use of any product data, diagrams, charts, programs, algorithms, or circuit application examples contained in these materials.
- All information contained in these materials, including product data, diagrams, charts, programs and algorithms represents information on products at the time of publication of these materials, and are subject to change by Mitsubishi Electric Corporation without notice due to product improvements or other reasons. It is therefore recommended that customers contact Mitsubishi Electric Corporation or an authorized Mitsubishi Semiconductor product distributor for the latest product information before purchasing a product listed herein.
- The information described here may contain technical inaccuracies or typographical errors. Mitsubishi Electric Corporation assumes no responsibility for any damage, liability, or other loss rising from these inaccuracies or errors. Please also pay attention to information published by Mitsubishi Electric Corporation by various means, including the Mitsubishi Semiconductor home page (<http://www.mitsubishichips.com>).
- When using any or all of the information contained in these materials, including product data, diagrams, charts, programs, and algorithms, please be sure to evaluate all information as a total system before making a final decision on the applicability of the information and products. Mitsubishi Electric Corporation assumes no responsibility for any damage, liability or other loss resulting from the information contained herein.
- Mitsubishi Electric Corporation semiconductors are not designed or manufactured for use in a device or system that is used under circumstances in which human life is potentially at stake. Please contact Mitsubishi Electric Corporation or an authorized Mitsubishi Semiconductor product distributor when considering the use of a product contained herein for any specific purposes, such as apparatus or systems for transportation, vehicular, medical, aerospace, nuclear, or undersea repeater use.
- The prior written approval of Mitsubishi Electric Corporation is necessary to reprint or reproduce in whole or in part these materials.
- If these products or technologies are subject to the Japanese export control restrictions, they must be exported under a license from the Japanese government and cannot be imported into a country other than the approved destination. Any diversion or reexport contrary to the export control laws and regulations of Japan and/or the country of destination is prohibited.
- Please contact Mitsubishi Electric Corporation or an authorized Mitsubishi Semiconductor product distributor for further details on these materials or the products contained therein.

REVISION DESCRIPTION LIST

M37272M6/M8-XXXSP/FP, M37272MA-XXXSP,
M37272E8SP/FP, M37272EFSP DATA SHEET

Rev. No.	Revision Description	Rev. date
1.0	First Edition of PDF File	0103