



DS8973 9-Digit LED Driver

General Description

The DS8973 is a 9-digit driver designed to operate from 3-cell battery supplies. Each driver will sink 100 mA to less than 0.7V when driven by only 0.1 mA. Each input is blocked by diodes so that the input can be driven below ground with virtually no current drain. This is especially important in calculator systems employing a DC-to-DC converter on the negative side of the battery. If the converter were on the positive side of the battery, the converter would have to handle all of the display current, as well as the MOS calculator chip current. But if it is on the negative side, it only has

to handle the MOS current. The DS8973 is designed for the more efficient operating mode.

Features

- Nine complete digit drivers
- Built-in low battery indicator
- High current outputs—100 mA
- Straight through pin out for easy board layout

Equivalent Circuit Diagrams

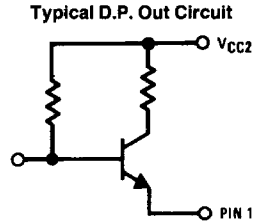
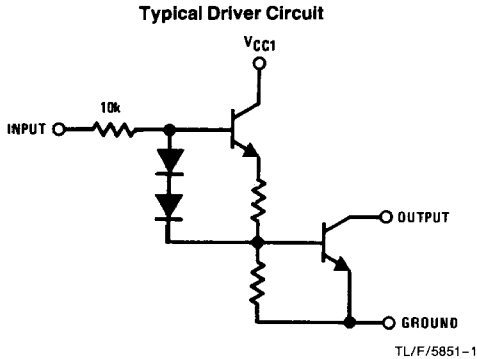

Connection Diagram

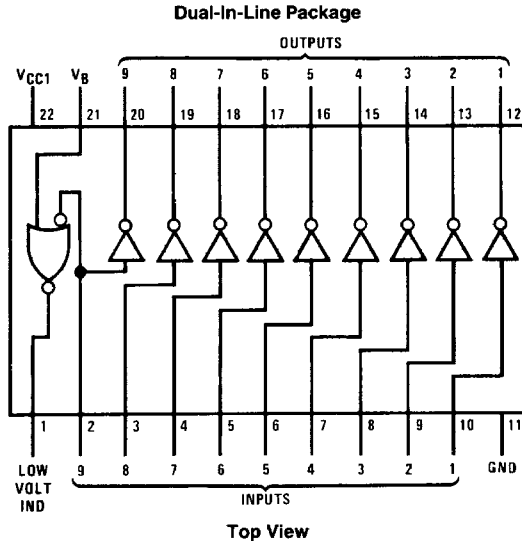

Order Number DS8973N
See NS Package Number N22A

Absolute Maximum Ratings (Note 1)

If Military/Aerospace specified devices are required, please contact the National Semiconductor Sales Office/Distributors for availability and specifications.

Supply Voltage	10V
Input Voltage	10V
Output Voltage	10V
Storage Temperature Range	-65°C to +150°C
Maximum Power Dissipation* at 25°C	
Molded Package	1673 mW
Lead Temperature (Soldering, 4 seconds)	260°C

*Derate molded package 13.39 mW/°C above 25°C.

Operating Conditions

	Min	Max	Units
Supply Voltage (V_B)	3.0	5.5	V
Supply Voltage (V_{CC1})	3.0	9.5	V
Temperature (T_A)	0	+70	°C

Electrical Characteristics

Symbol	Parameter	Conditions	Min	Typ	Max	Units
V_{IH}	Logical "1" Input Voltage	$V_{CC} = \text{Max}$	3.9			V
I_{IH}	Logical "1" Input Current	$V_{CC} = \text{Max}, V_{IH} = 3.9V$	0.1		0.3	mA
V_{IL}	Logical "0" Input Voltage	$V_{CC} = \text{Max}$			0.5	V
I_{IL}	Logical "0" Input Current	$V_{CC} = \text{Max}, V_{IL} = 0.5V$			40	μA
V_{BH}	High Battery Threshold	$V_{OT}(\text{Pin } 1) = 1V, I_{OT} \leq -50 \mu A,$ $T_A = 25^\circ C, V_{IH}(\text{Pin } 2) = 3.9V$	DS8973 3.6			V
V_{BL}	Low Battery Threshold	$V_{OT}(\text{Pin } 1) = 2.1V, I_{OT} \leq -6 \text{ mA},$ $T_A = 25^\circ C, V_{IH}(\text{Pin } 2) = 3.9V$	DS8973		3.2	V
I_{CEX}	Logical "1" Output Current	$V_{CC} = \text{Min}, V_{OH} = 9.5V, V_{IL} = 0.5V$			50	μA
V_{OL}	Logical "0" Output Voltage	$V_{CC} = \text{Min}, I_{OL} = 100 \text{ mA}, V_{IH} = 3.9V$			0.7	V
I_{CC1}	Supply Current	$V_{CC} = \text{Max}, \text{One Input "ON"}$			6	mA
I_B	Pin 21 (High Battery Supply)	$V_{CC} = \text{Max}, V_B = \text{Max}$			1.2	mA

Note 1: "Absolute Maximum Ratings" are those values beyond which the safety of the device cannot be guaranteed. They are not meant to imply that the devices should be operated at these limits. The table of "Electrical Characteristics" provides conditions for actual device operation.

Note 2: Unless otherwise specified, min/max limits apply across the 0°C to +70°C range. All typicals are given for $T_A = 25^\circ C$.

Note 3: All currents into device pins shown as positive, out of device pins as negative, all voltages referenced to ground unless otherwise noted. All values shown as max or min on absolute value basis.