



FAN3213 / FAN3214

Dual-4 A, High-Speed, Low-Side Gate Drivers

Features

- Industry-Standard Pin Out
- 4.5 to 18 V Operating Range
- 5 A Peak Sink/Source at $V_{DD} = 12\text{ V}$
- 4.3 A Sink / 2.8 A Source at $V_{OUT} = 6\text{ V}$
- TTL Input Thresholds
- Two Versions of Dual Independent Drivers:
 - Dual Inverting (FAN3213)
 - Dual Non-Inverting (FAN3214)
- Internal Resistors Turn Driver Off If No Inputs
- MillerDrive™ Technology
- 12 ns / 9 ns Typical Rise/Fall Times with 2.2 nF Load
- Typical Propagation Delay Under 20 ns Matched within 1 ns to the Other Channel
- Double Current Capability by Paralleling Channels
- Standard SOIC-8 Package
- Rated from -40°C to $+125^{\circ}\text{C}$ Ambient
- Automotive Qualified to AEC-Q100 (F085 Version)

Description

The FAN3213 and FAN3214 dual 4 A gate drivers are designed to drive N-channel enhancement-mode MOSFETs in low-side switching applications by providing high peak current pulses during the short switching intervals. They are both available with TTL input thresholds. Internal circuitry provides an under-voltage lockout function by holding the output LOW until the supply voltage is within the operating range. In addition, the drivers feature matched internal propagation delays between A and B channels for applications requiring dual gate drives with critical timing, such as synchronous rectifiers. This also enables connecting two drivers in parallel to effectively double the current capability driving a single MOSFET.

The FAN3213/14 drivers incorporate MillerDrive™ architecture for the final output stage. This bipolar-MOSFET combination provides high current during the Miller plateau stage of the MOSFET turn-on / turn-off process to minimize switching loss, while providing rail-to-rail voltage swing and reverse current capability.

The FAN3213 offers two inverting drivers and the FAN3214 offers two non-inverting drivers. Both are offered in a standard 8-pin SOIC package.

Applications

- Switch-Mode Power Supplies
- High-Efficiency MOSFET Switching
- Synchronous Rectifier Circuits
- DC-to-DC Converters
- Motor Control
- Automotive-Qualified Systems (F085 version)

Related Resources

[AN-6069 — Application Review and Comparative Evaluation of Low-Side Gate Drivers](#)



Figure 1. Pin Configurations

Ordering Information

Part Number	Logic	Input Threshold	Package	Packing Method	Quantity per Reel
FAN3213TMX	Dual Inverting Channels	TTL	SOIC-8	Tape & Reel	2,500
FAN3214TMX	Dual Non-Inverting Channels				
FAN3213TMX_F085 ⁽¹⁾	Dual Inverting Channels				
FAN3214TMX_F085 ⁽¹⁾	Dual Non-Inverting Channels				

Note:

1. Qualified to AEC-Q100

Package Outlines

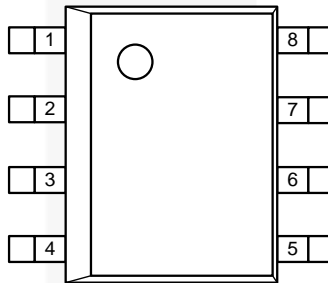

Figure 2. SOIC-8 (Top View)

Thermal Characteristics⁽²⁾

Package	Θ_{JL} ⁽³⁾	Θ_{JT} ⁽⁴⁾	Θ_{JA} ⁽⁵⁾	Ψ_{JB} ⁽⁶⁾	Ψ_{JT} ⁽⁷⁾	Unit
8-Pin Small Outline Integrated Circuit (SOIC)	38	29	87	41	2.3	°C/W

Notes:

2. Estimates derived from thermal simulation; actual values depend on the application.
3. Θ_{JL} (Θ_{JL}): Thermal resistance between the semiconductor junction and the bottom surface of all the leads (including any thermal pad) that are typically soldered to a PCB.
4. Θ_{JT} (Θ_{JT}): Thermal resistance between the semiconductor junction and the top surface of the package, assuming it is held at a uniform temperature by a top-side heatsink.
5. Θ_{JA} (Θ_{JA}): Thermal resistance between junction and ambient, dependent on the PCB design, heat sinking, and airflow. The value given is for natural convection with no heatsink, using a 2S2P board, as specified in JEDEC standards JESD51-2, JESD51-5, and JESD51-7, as appropriate.
6. Ψ_{JB} (Ψ_{JB}): Thermal characterization parameter providing correlation between semiconductor junction temperature and an application circuit board reference point for the thermal environment defined in Note 5. For the SOIC-8 package, the board reference is defined as the PCB copper adjacent to pin 6.
7. Ψ_{JT} (Ψ_{JT}): Thermal characterization parameter providing correlation between the semiconductor junction temperature and the center of the top of the package for the thermal environment defined in Note 5.

Pin Configurations

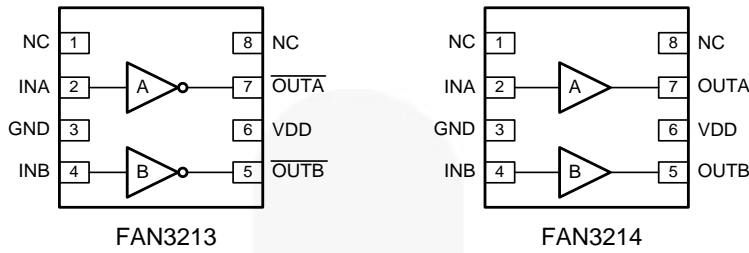

Figure 3. Pin Configurations (Repeated)

Pin Definitions

Pin	Name	Pin Description
1	NC	No Connect. This pin can be grounded or left floating.
2	INA	Input to Channel A.
3	GND	Ground. Common ground reference for input and output circuits.
4	INB	Input to Channel B.
5 (FAN3213)	$\overline{\text{OUTB}}$	Gate Drive Output B (inverted from the input): Held LOW unless required input is present and V_{DD} is above UVLO threshold.
5 (FAN3214)	OUTB	Gate Drive Output B: Held LOW unless required input(s) are present and V_{DD} is above UVLO threshold.
6	VDD	Supply Voltage. Provides power to the IC.
7 (FAN3213)	$\overline{\text{OUTA}}$	Gate Drive Output A (inverted from the input): Held LOW unless required input is present and V_{DD} is above UVLO threshold.
7 (FAN3214)	OUTA	Gate Drive Output A: Held LOW unless required input(s) are present and V_{DD} is above UVLO threshold.
8	NC	No Connect. This pin can be grounded or left floating.

Output Logic

FAN3213 (x=A or B)		FAN3214 (x=A or B)	
INx	$\overline{\text{OUTx}}$	INx	OUTx
0	1	0 ⁽⁹⁾	0
1 ⁽⁹⁾	0	1	1

Note:

9. Default input signal if no external connection is made.

Block Diagrams

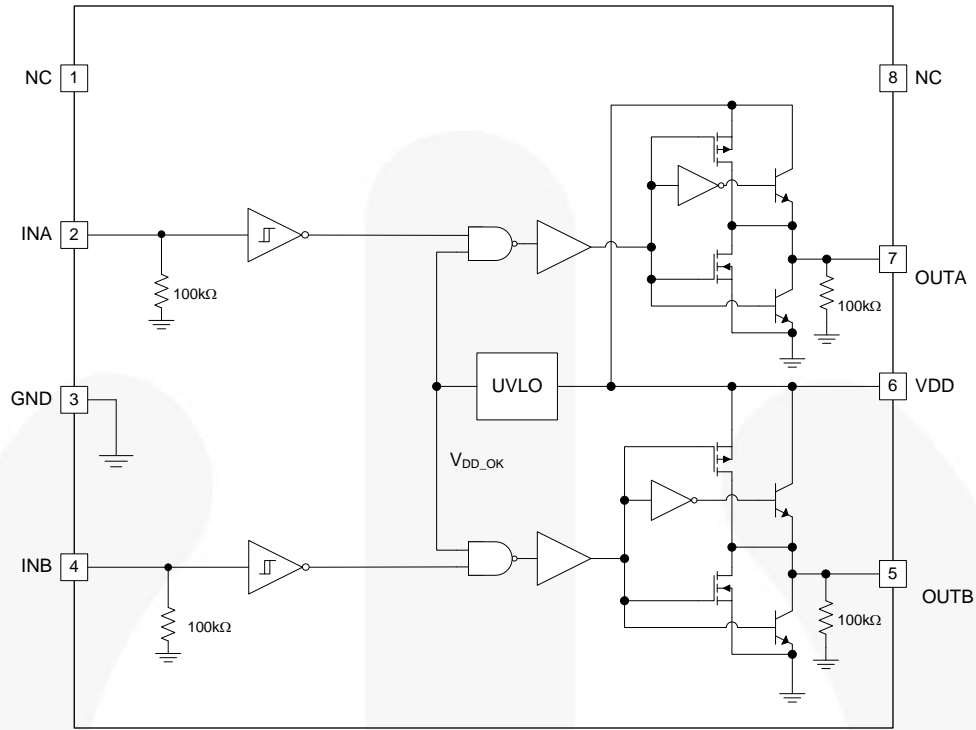

Figure 4. FAN3213 Block Diagram

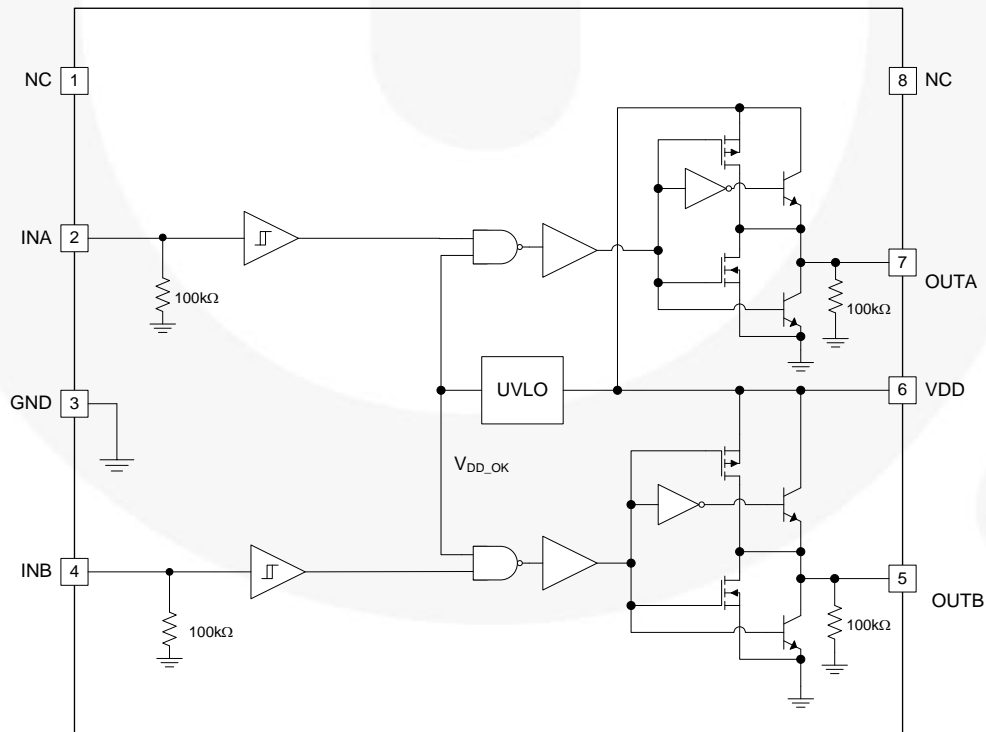

Figure 5. FAN3214 Block Diagram

Absolute Maximum Ratings

Stresses exceeding the absolute maximum ratings may damage the device. The device may not function or be operable above the recommended operating conditions and stressing the parts to these levels is not recommended. In addition, extended exposure to stresses above the recommended operating conditions may affect device reliability. The absolute maximum ratings are stress ratings only.

Symbol	Parameter	Min.	Max.	Unit
V_{DD}	VDD to PGND	-0.3	20.0	V
V_{IN}	INA and INB to GND	GND - 0.3	$V_{DD} + 0.3$	V
V_{OUT}	OUTA and OUTB to GND	GND - 0.3	$V_{DD} + 0.3$	V
T_L	Lead Soldering Temperature (10 Seconds)		+260	°C
T_J	Junction Temperature	-55	+150	°C
T_{STG}	Storage Temperature	-65	+150	°C

Recommended Operating Conditions

The Recommended Operating Conditions table defines the conditions for actual device operation. Recommended operating conditions are specified to ensure optimal performance to the datasheet specifications. Fairchild does not recommend exceeding them or designing to Absolute Maximum Ratings.

Symbol	Parameter	Min.	Max.	Unit
V_{DD}	Supply Voltage Range	4.5	18.0	V
V_{IN}	Input Voltage INA and INB	0	V_{DD}	V
T_A	Operating Ambient Temperature	-40	+125	°C

Electrical Characteristics

Unless otherwise noted, $V_{DD}=12\text{ V}$, $T_J=-40^\circ\text{C}$ to $+125^\circ\text{C}$. Currents are defined as positive into the device and negative out of the device.

Symbol	Parameter	Conditions	Min.	Typ.	Max.	Unit
Supply						
FAN321xT						
V_{DD}	Operating Range		4.5		18.0	V
I_{DD}	Supply Current, Inputs Not Connected			0.70	0.95	mA
V_{ON}	Turn-On Voltage	INA= V_{DD} , INB=0 V	3.5	3.9	4.3	V
V_{OFF}	Turn-Off Voltage	INA= V_{DD} , INB=0 V	3.3	3.7	4.1	V
FAN321xTMX_F085 (Automotive-Qualified Versions)						
I_{DD}	Supply Current, Inputs Not Connected ⁽¹²⁾			0.70	1.20	mA
V_{ON}	Turn-On Voltage ⁽¹²⁾	INA= V_{DD} , INB=0 V	3.3	3.9	4.5	V
V_{OFF}	Turn-Off Voltage ⁽¹²⁾	INA= V_{DD} , INB=0 V	3.1	3.7	4.3	V
Inputs						
V_{IL_T}	INx Logic Low Threshold		0.8	1.2		V
V_{IH_T}	INx Logic High Threshold			1.6	2.0	V
FAN321xT						
I_{IN+}	Non-Inverting Input	IN from 0 to V_{DD}	-1.5		175.0	μA
I_{IN-}	Inverting Input	IN from 0 to V_{DD}	-175.0		1.5	μA
V_{HYS_T}	TTL Logic Hysteresis Voltage		0.2	0.4	0.8	V
FAN321xTMX_F085 (Automotive-Qualified Versions)						
I_{INx_T}	Non-inverting Input Current ⁽¹²⁾	IN=0 V	-1.5		1.5	μA
I_{INx_T}	Non-inverting Input Current ⁽¹²⁾	IN= V_{DD}	90	120	175	μA
I_{INx_T}	Inverting Input Current ⁽¹²⁾	IN=0 V	-175	-120	-90	μA
I_{INx_T}	Inverting Input Current ⁽¹²⁾	IN= V_{DD}	-1.5		1.5	μA
V_{HYS_T}	TTL Logic Hysteresis Voltage ⁽¹²⁾		0.1	0.4	0.8	V
Output						
I_{SINK}	OUT Current, Mid-Voltage, Sinking ⁽¹⁰⁾	OUTx at $V_{DD}/2$, $C_{LOAD}=0.22\ \mu\text{F}$, $f=1\ \text{kHz}$		4.3		A
I_{SOURCE}	OUT Current, Mid-Voltage, Sourcing ⁽¹⁰⁾	OUTx at $V_{DD}/2$, $C_{LOAD}=0.22\ \mu\text{F}$, $f=1\ \text{kHz}$		-2.8		A
I_{PK_SINK}	OUT Current, Peak, Sinking ⁽¹⁰⁾	$C_{LOAD}=0.22\ \mu\text{F}$, $f=1\ \text{kHz}$		5		A
I_{PK_SOURCE}	OUT Current, Peak, Sourcing ⁽¹⁰⁾	$C_{LOAD}=0.22\ \mu\text{F}$, $f=1\ \text{kHz}$		-5		A
I_{RVS}	Output Reverse Current Withstand ⁽¹⁰⁾			500		mA
T_{DEL_MATCH}	Propagation Matching Between Channels	INA=INB, OUTA and OUTB at 50% Point		2	4	ns

Continued on the following page...

Electrical Characteristics (Continued)

Unless otherwise noted, $V_{DD}=12\text{ V}$, $T_J=-40^\circ\text{C}$ to $+125^\circ\text{C}$. Currents are defined as positive into the device and negative out of the device.

Symbol	Parameter	Conditions	Min.	Typ.	Max.	Unit
FAN321xT						
t_{RISE}	Output Rise Time ⁽¹¹⁾	$C_{LOAD}=2200\text{ pF}$		12	20	ns
t_{FALL}	Output Fall Time ⁽¹¹⁾	$C_{LOAD}=2200\text{ pF}$		9	17	ns
t_{D1}, t_{D2}	Output Propagation Delay, TTL Inputs ⁽¹¹⁾	$0 - 5 V_{IN}, 1\text{ V/ns Slew Rate}$	9	17	29	ns
FAN321xTMX_F085 (Automotive-Qualified Versions)						
t_{RISE}	Output Rise Time ⁽¹¹⁾⁽¹²⁾	$C_{LOAD}=2200\text{ pF}$		12	22	ns
t_{FALL}	Output Fall Time ⁽¹¹⁾⁽¹²⁾	$C_{LOAD}=2200\text{ pF}$		9	18	ns
t_{D1}, t_{D2}	Output Propagation Delay, TTL Inputs ⁽¹¹⁾⁽¹²⁾	$0 - 5 V_{IN}, 1\text{ V/ns Slew Rate}$	9	17	32	ns
V_{OH}	High Level Output Voltage ⁽¹²⁾	$V_{OH}=V_{DD}-V_{OUT}, I_{OUT}=-1\text{ mA}$		15	35	mV
V_{OL}	Low Level Output Voltage ⁽¹²⁾	$I_{OUT}=1\text{ mA}$		10	25	mV

Notes:

- 10. Not tested in production.
- 11. See Timing Diagrams of Figure 6 and Figure 7.
- 12. Apply only to Automotive Version(FAN321xTMX_F085)

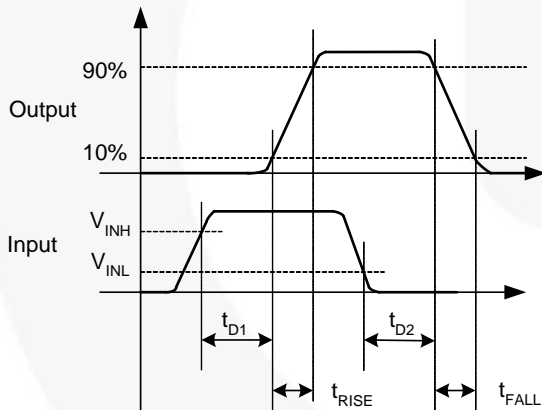

Figure 6. Non-Inverting Timing Diagram

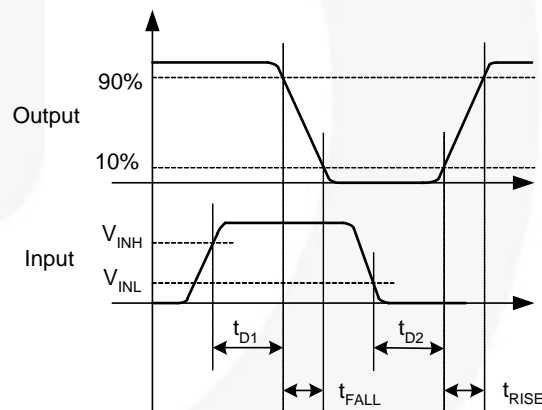

Figure 7. Inverting Timing Diagram

Typical Performance Characteristics

Typical characteristics are provided at $T_A=25^\circ\text{C}$ and $V_{DD}=12\text{ V}$ unless otherwise noted.

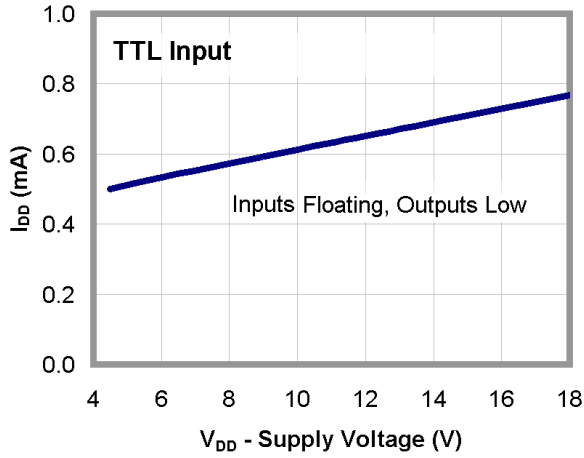

Figure 8. I_{DD} (Static) vs. Supply Voltage⁽¹²⁾

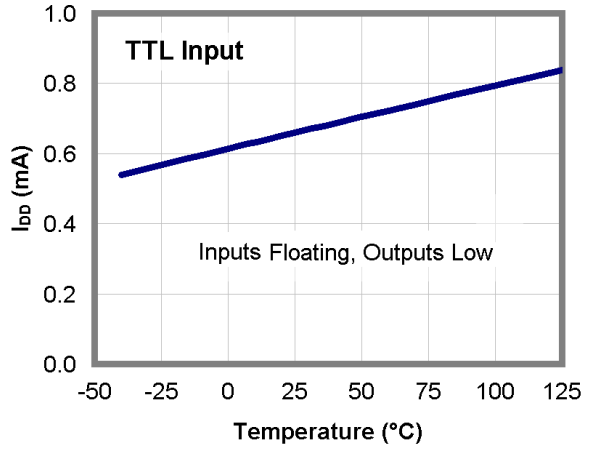

Figure 9. I_{DD} (Static) vs. Temperature⁽¹²⁾

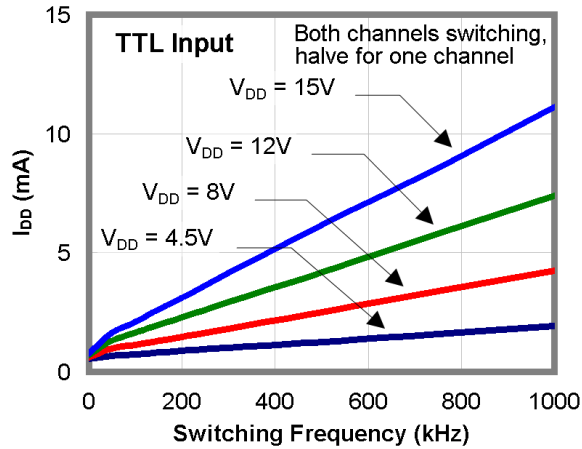

Figure 10. I_{DD} (No Load) vs. Frequency

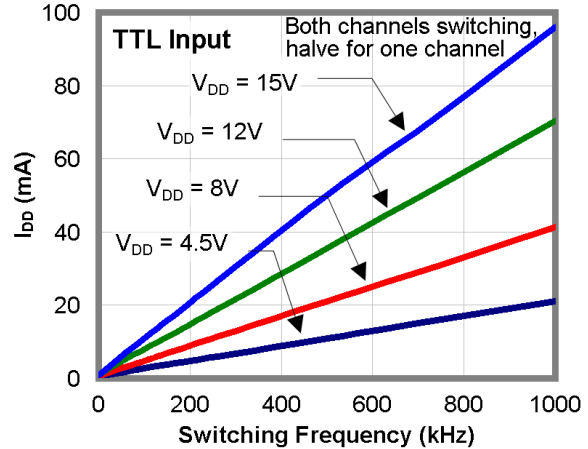

Figure 11. I_{DD} (2.2 nF Load) vs. Frequency

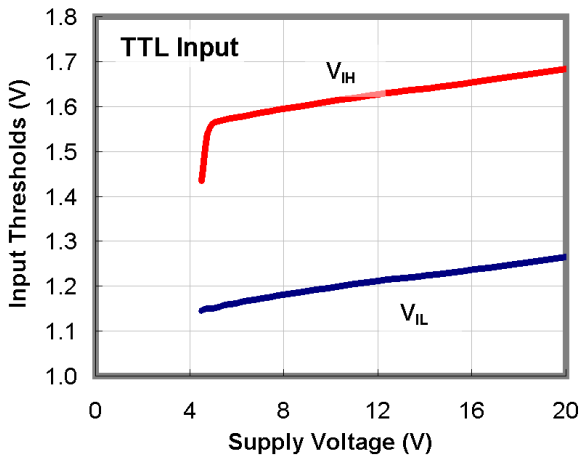

Figure 12. Input Thresholds vs. Supply Voltage

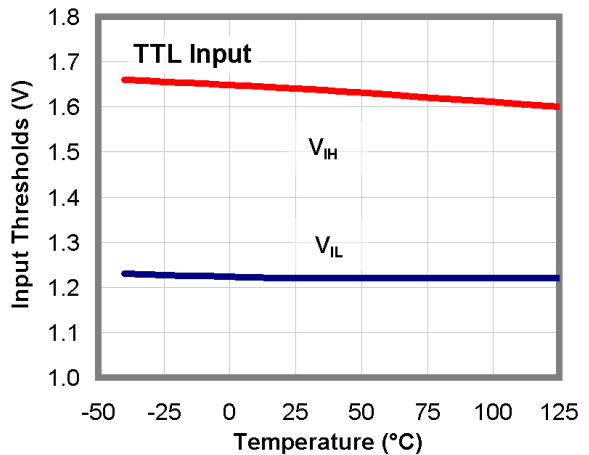
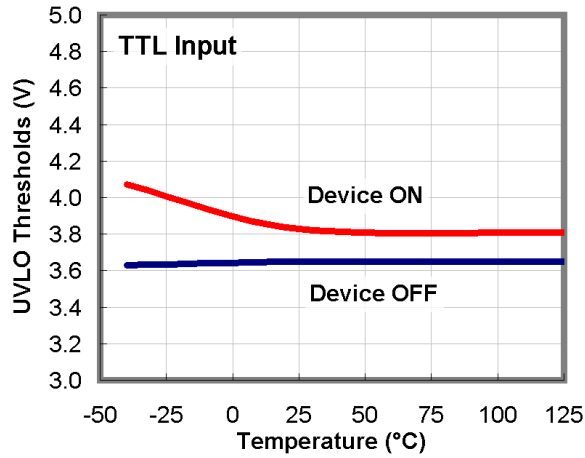

Figure 13. Input Thresholds vs. Temperature

Typical Performance Characteristics

Typical characteristics are provided at $T_A=25^\circ\text{C}$ and $V_{DD}=12\text{ V}$ unless otherwise noted.



UVLO Threshold vs. Temperature

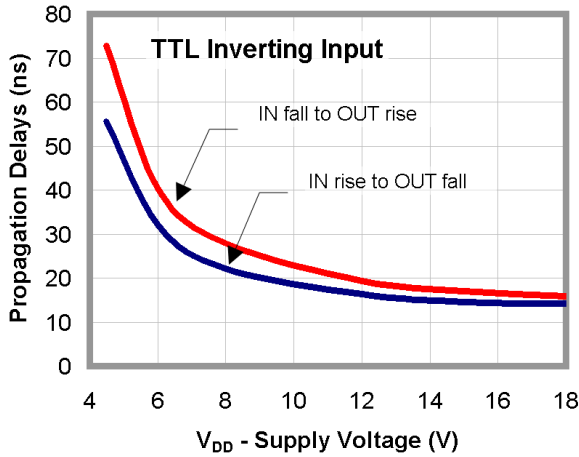

Figure 14. Propagation Delay vs. Supply Voltage

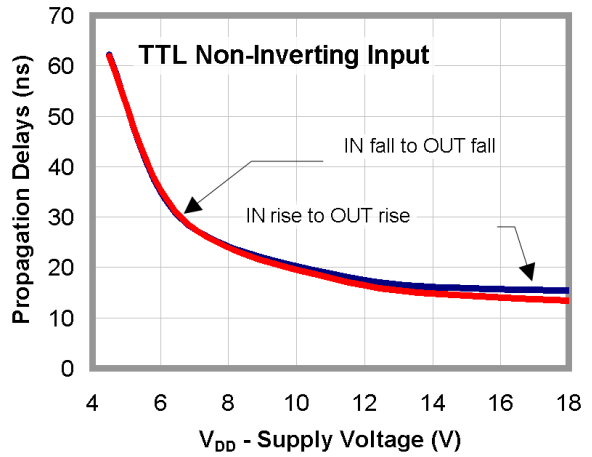

Figure 15. Propagation Delay vs. Supply Voltage

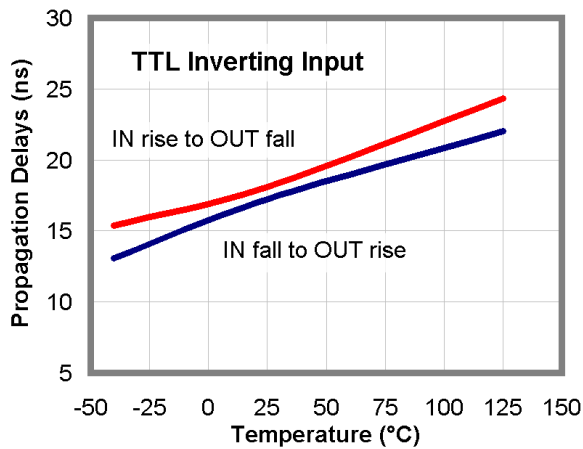

Figure 16. Propagation Delays vs. Temperature

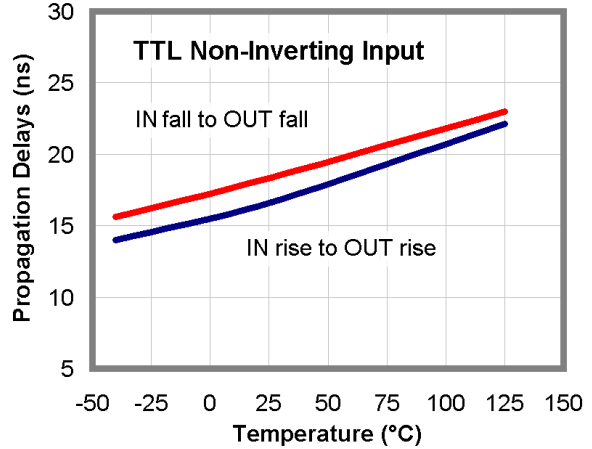

Figure 17. Propagation Delays vs. Temperature

Typical Performance Characteristics

Typical characteristics are provided at $T_A=25^\circ\text{C}$ and $V_{DD}=12\text{ V}$ unless otherwise noted.

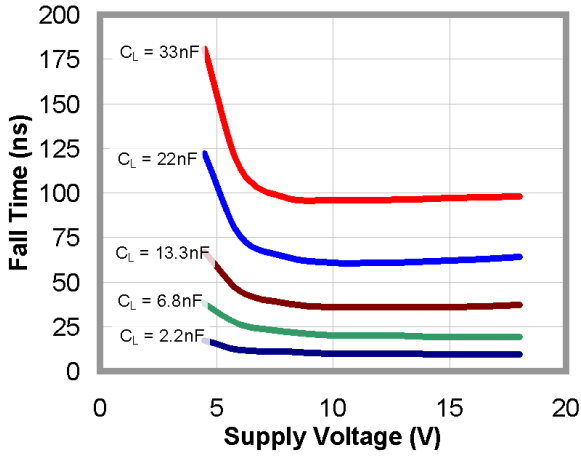

Figure 18. Fall Time vs. Supply Voltage

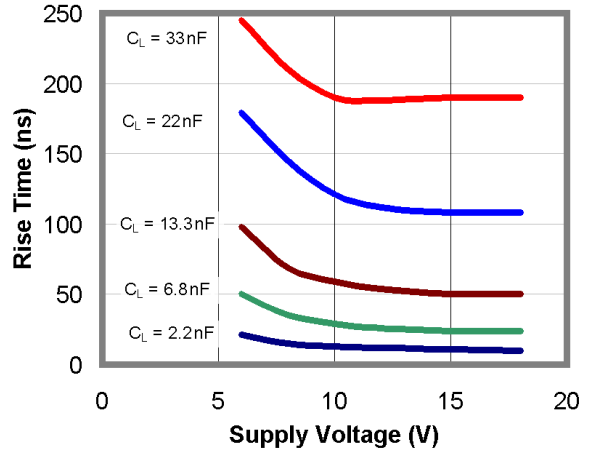

Figure 19. Rise Time vs. Supply Voltage

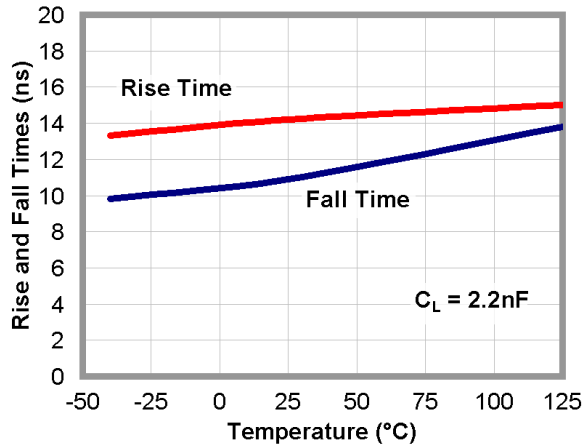

Figure 20. Rise and Fall Times vs. Temperature

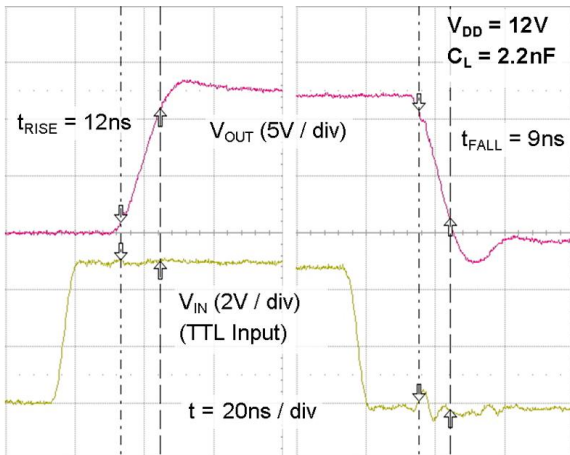

Figure 21. Rise/Fall Waveforms with 2.2 nF Load

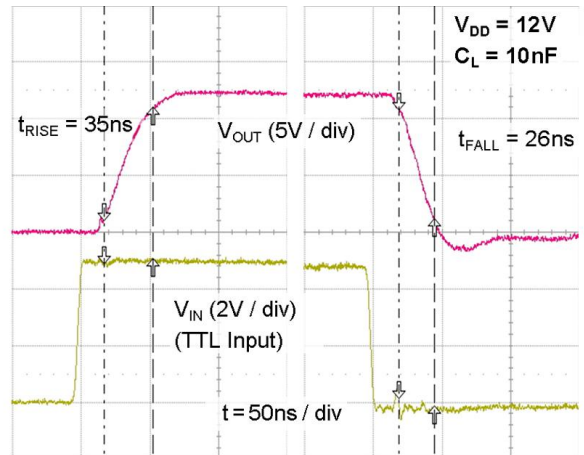

Figure 22. Rise/Fall Waveforms with 10 nF Load

Typical Performance Characteristics

Typical characteristics are provided at $T_A=25^\circ\text{C}$ and $V_{DD}=12\text{ V}$ unless otherwise noted.

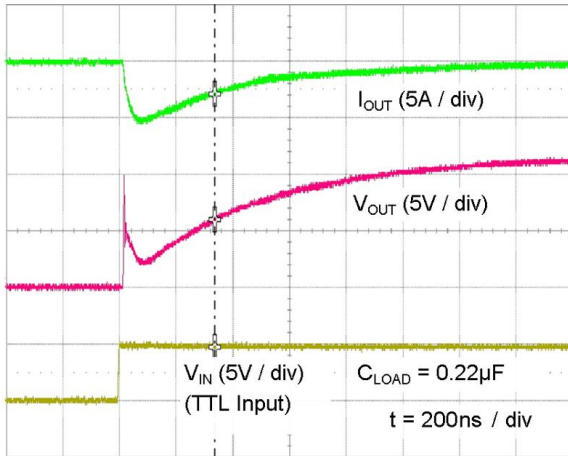

Figure 23. Quasi-Static Source Current with $V_{DD}=12\text{ V}$ ⁽¹³⁾

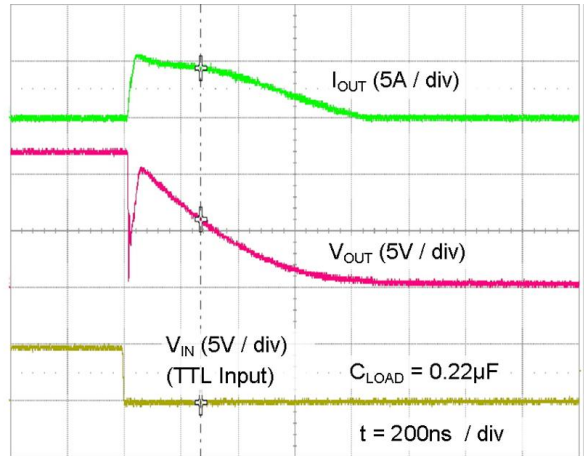

Figure 24. Quasi-Static Sink Current with $V_{DD}=12\text{ V}$ ⁽¹³⁾

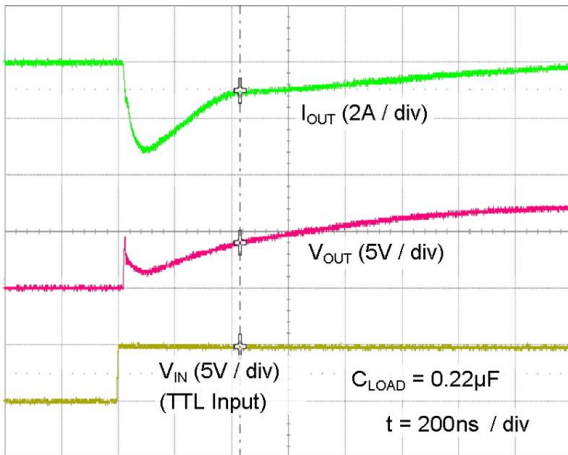

Figure 25. Quasi-Static Source Current with $V_{DD}=8\text{ V}$ ⁽¹⁴⁾

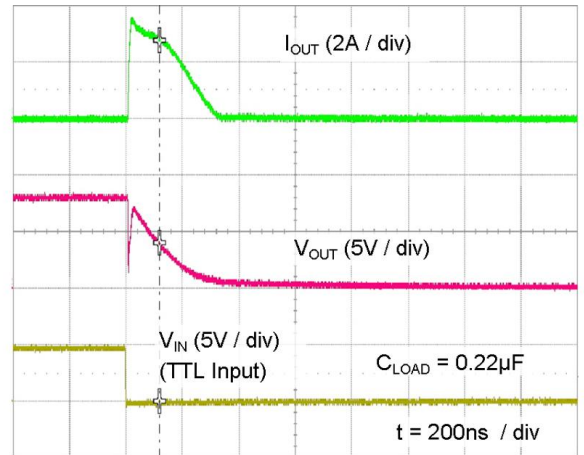

Figure 26. Quasi-Static Sink Current with $V_{DD}=8\text{ V}$ ⁽¹⁴⁾

Notes:

13. For any inverting inputs pulled low, non-inverting inputs pulled high, or outputs driven high; static I_{DD} increases by the current flowing through the corresponding pull-up/down resistor shown in Figure 4 and Figure 5.

14. The initial spike in each current waveform is a measurement artifact caused by the stray inductance of the current-measurement loop.

Test Circuit

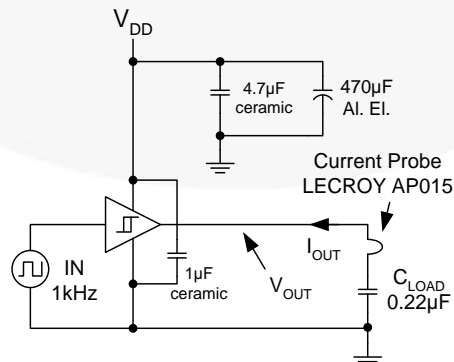

Figure 27. Quasi-Static I_{OUT} / V_{OUT} Test Circuit

Applications Information

Input Thresholds

The FAN3213 and the FAN3214 drivers consist of two identical channels that may be used independently at rated current or connected in parallel to double the individual current capacity.

The input thresholds meet industry-standard TTL-logic thresholds independent of the V_{DD} voltage, and there is a hysteresis voltage of approximately 0.4 V. These levels permit the inputs to be driven from a range of input logic signal levels for which a voltage over 2 V is considered logic HIGH. The driving signal for the TTL inputs should have fast rising and falling edges with a slew rate of 6 V/ μ s or faster, so a rise time from 0 to 3.3 V should be 550 ns or less. With reduced slew rate, circuit noise could cause the driver input voltage to exceed the hysteresis voltage and retrigger the driver input, causing erratic operation.

Static Supply Current

In the I_{DD} (static) typical performance characteristics shown in Figure 8 and Figure 9, each curve is produced with both inputs floating and both outputs LOW to indicate the lowest static I_{DD} current. For other states, additional current flows through the 100 k Ω resistors on the inputs and outputs shown in the block diagram of each part (see Figure 4 and Figure 5). In these cases, the actual static I_{DD} current is the value obtained from the curves plus this additional current.

MillerDrive™ Gate Drive Technology

FAN3213 and FAN3214 gate drivers incorporate the MillerDrive™ architecture shown in Figure 28. For the output stage, a combination of bipolar and MOS devices provide large currents over a wide range of supply voltage and temperature variations. The bipolar devices carry the bulk of the current as OUT swings between 1/3 to 2/3 V_{DD} and the MOS devices pull the output to the HIGH or LOW rail.

The purpose of the MillerDrive™ architecture is to speed up switching by providing high current during the Miller plateau region when the gate-drain capacitance of the MOSFET is being charged or discharged as part of the turn-on / turn-off process.

For applications with zero voltage switching during the MOSFET turn-on or turn-off interval, the driver supplies high peak current for fast switching even though the Miller plateau is not present. This situation often occurs in synchronous rectifier applications because the body diode is generally conducting before the MOSFET is switched ON.

The output pin slew rate is determined by V_{DD} voltage and the load on the output. It is not user adjustable, but a series resistor can be added if a slower rise or fall time at the MOSFET gate is needed.

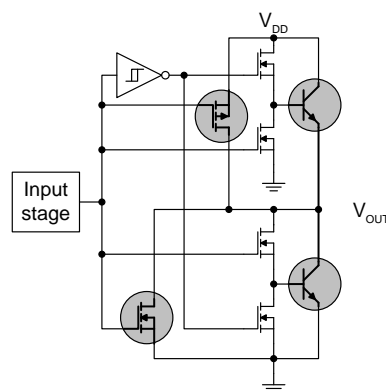

Figure 28. MillerDrive™ Output Architecture

Under-Voltage Lockout

The FAN321x startup logic is optimized to drive ground-referenced N-channel MOSFETs with an under-voltage lockout (UVLO) function to ensure that the IC starts up in an orderly fashion. When V_{DD} is rising, yet below the 3.9 V operational level, this circuit holds the output LOW, regardless of the status of the input pins. After the part is active, the supply voltage must drop 0.2 V before the part shuts down. This hysteresis helps prevent chatter when low V_{DD} supply voltages have noise from the power switching. This configuration is not suitable for driving high-side P-channel MOSFETs because the low output voltage of the driver would turn the P-channel MOSFET on with V_{DD} below 3.9 V.

V_{DD} Bypass Capacitor Guidelines

To enable this IC to turn a device ON quickly, a local high-frequency bypass capacitor, C_{BYP} , with low ESR and ESL should be connected between the VDD and GND pins with minimal trace length. This capacitor is in addition to bulk electrolytic capacitance of 10 μ F to 47 μ F commonly found on driver and controller bias circuits.

A typical criterion for choosing the value of C_{BYP} is to keep the ripple voltage on the V_{DD} supply to $\leq 5\%$. This is often achieved with a value ≥ 20 times the equivalent load capacitance C_{EQV} , defined here as Q_{GATE}/V_{DD} . Ceramic capacitors of 0.1 μ F to 1 μ F or larger are common choices, as are dielectrics, such as X5R and X7R, with good temperature characteristics and high pulse current capability.

If circuit noise affects normal operation, the value of C_{BYP} may be increased, to 50-100 times the C_{EQV} , or C_{BYP} may be split into two capacitors. One should be a larger value, based on equivalent load capacitance, and the other a smaller value, such as 1-10 nF mounted closest to the VDD and GND pins to carry the higher-frequency components of the current pulses. The bypass capacitor must provide the pulsed current from both of the driver channels and, if the drivers are switching simultaneously, the combined peak current sourced from the C_{BYP} would be twice as large as when a single channel is switching.

Layout and Connection Guidelines

The FAN3213 and FAN3214 gate drivers incorporate fast-reacting input circuits, short propagation delays, and powerful output stages capable of delivering current peaks over 4 A to facilitate voltage transition times from under 10 ns to over 150 ns. The following layout and connection guidelines are strongly recommended:

- Keep high-current output and power ground paths separate from logic input signals and signal ground paths. This is especially critical for TTL-level logic thresholds at driver input pins.
- Keep the driver as close to the load as possible to minimize the length of high-current traces. This reduces the series inductance to improve high-speed switching, while reducing the loop area that can radiate EMI to the driver inputs and surrounding circuitry.
- If the inputs to a channel are not externally connected, the internal 100 kΩ resistors indicated on block diagrams command a low output. In noisy environments, it may be necessary to tie inputs of an unused channel to VDD or GND using short traces to prevent noise from causing spurious output switching.
- Many high-speed power circuits can be susceptible to noise injected from their own output or other external sources, possibly causing output re-triggering. These effects can be obvious if the circuit is tested in breadboard or non-optimal circuit layouts with long input or output leads. For best results, make connections to all pins as short and direct as possible.
- FAN3213 and FAN3214 are pin-compatible with many other industry-standard drivers.
- The turn-on and turn-off current paths should be minimized, as discussed in the following section.

Figure 29 shows the pulsed gate drive current path when the gate driver is supplying gate charge to turn the MOSFET on. The current is supplied from the local bypass capacitor, C_{BYP} , and flows through the driver to the MOSFET gate and to ground. To reach the high peak currents possible, the resistance and inductance in the path should be minimized. The localized C_{BYP} acts to contain the high peak current pulses within this driver-MOSFET circuit, preventing them from disturbing the sensitive analog circuitry in the PWM controller.

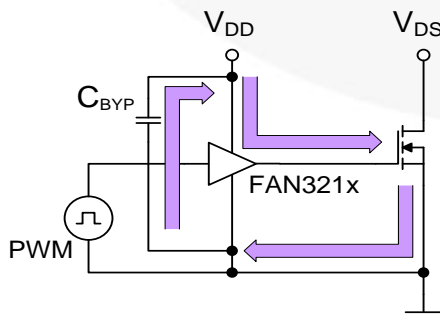

Figure 29. Current Path for MOSFET Turn-On

Figure 30 shows the current path when the gate driver turns the MOSFET OFF. Ideally, the driver shunts the current directly to the source of the MOSFET in a small circuit loop. For fast turn-off times, the resistance and inductance in this path should be minimized.

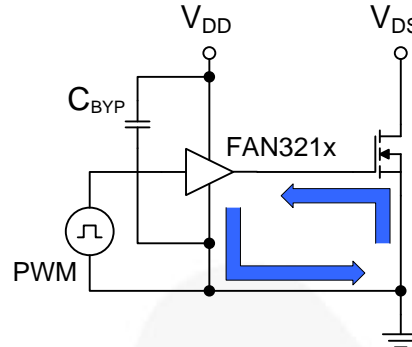

Figure 30. Current Path for MOSFET Turn-Off

Operational Waveforms

At power-up, the driver output remains LOW until the V_{DD} voltage reaches the turn-on threshold. The magnitude of the OUT pulses rises with V_{DD} until steady-state V_{DD} is reached. The non-inverting operation illustrated in Figure 31 shows that the output remains LOW until the UVLO threshold is reached, then the output is in-phase with the input.

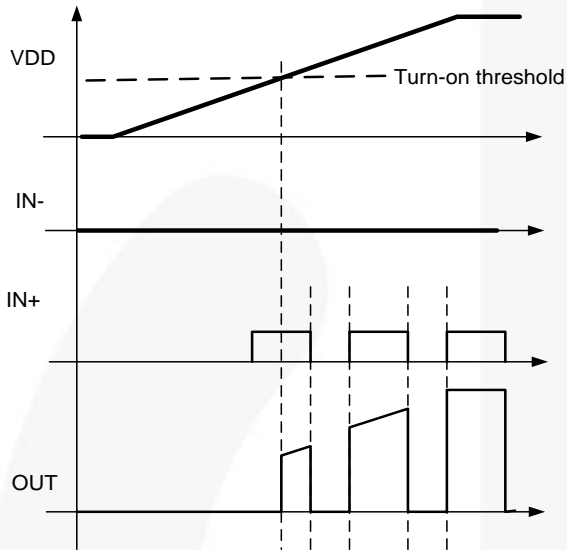

Figure 31. Non-Inverting Startup Waveforms

The inverting configuration of startup waveforms are shown in Figure 32. With $IN+$ tied to V_{DD} and the input signal applied to $IN-$, the OUT pulses are inverted with respect to the input. At power-up, the inverted output remains LOW until the V_{DD} voltage reaches the turn-on threshold, then it follows the input with inverted phase.

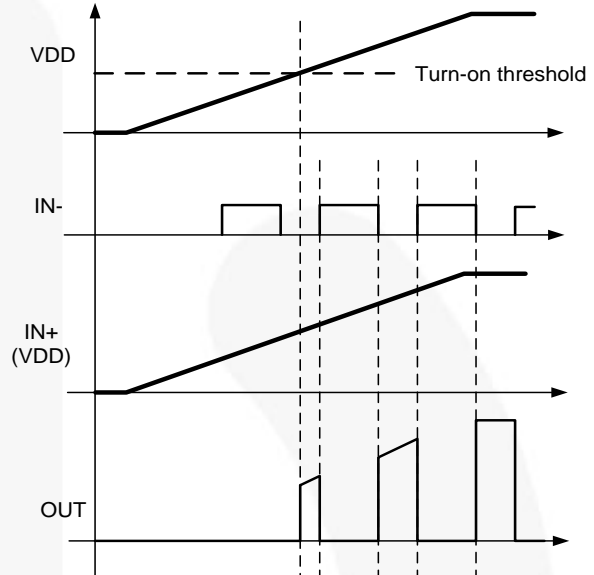

Figure 32. Inverting Startup Waveforms

Thermal Guidelines

Gate drivers used to switch MOSFETs and IGBTs at high frequencies can dissipate significant amounts of power. It is important to determine the driver power dissipation and the resulting junction temperature in the application to ensure that the part is operating within acceptable temperature limits.

The total power dissipation in a gate driver is the sum of two components, P_{GATE} and $P_{DYNAMIC}$:

$$P_{TOTAL} = P_{GATE} + P_{DYNAMIC} \quad (1)$$

P_{GATE} (Gate Driving Loss): The most significant power loss results from supplying gate current (charge per unit time) to switch the load MOSFET on and off at the switching frequency. The power dissipation that results from driving a MOSFET at a specified gate-source voltage, V_{GS} , with gate charge, Q_G , at switching frequency, f_{SW} , is determined by:

$$P_{GATE} = Q_G \cdot V_{GS} \cdot f_{SW} \cdot n \quad (2)$$

where n is the number of driver channels in use (1 or 2).

$P_{DYNAMIC}$ (Dynamic Pre-Drive / Shoot-through Current): A power loss resulting from internal current consumption under dynamic operating conditions, including pin pull-up / pull-down resistors. The internal current consumption ($I_{DYNAMIC}$) can be estimated using the graphs in Figure 10 of the Typical Performance Characteristics to determine the current $I_{DYNAMIC}$ drawn from V_{DD} under actual operating conditions:

$$P_{DYNAMIC} = I_{DYNAMIC} \cdot V_{DD} \cdot n \quad (3)$$

where n is the number of driver ICs in use. Note that n is usually be one IC even if the IC has two channels, unless two or more driver ICs are in parallel to drive a large load.

Once the power dissipated in the driver is determined, the driver junction rise with respect to circuit board can be evaluated using the following thermal equation, assuming Ψ_{JB} was determined for a similar thermal design (heat sinking and air flow):

$$T_J = P_{TOTAL} \cdot \Psi_{JB} + T_B \quad (4)$$

where:

T_J = driver junction temperature;

Ψ_{JB} = (psi) thermal characterization parameter relating temperature rise to total power dissipation; and

T_B = board temperature in location as defined in the Thermal Characteristics table.

To give a numerical example, assume for a 12 V VDD (Vibas) system, the synchronous rectifier switches of Figure 33 have a total gate charge of 60 nC at $V_{GS} = 7$ V. Therefore, two devices in parallel would have 120 nC gate charge. At a switching frequency of 300 kHz, the total power dissipation is:

$$P_{GATE} = 120 \text{ nC} \cdot 7 \text{ V} \cdot 300 \text{ kHz} \cdot 2 = 0.504 \text{ W} \quad (5)$$

$$P_{DYNAMIC} = 3.0 \text{ mA} \cdot 12 \text{ V} \cdot 1 = 0.036 \text{ W} \quad (6)$$

$$P_{TOTAL} = 0.540 \text{ W} \quad (7)$$

The SOIC-8 has a junction-to-board thermal characterization parameter of $\Psi_{JB} = 42^\circ\text{C/W}$. In a system application, the localized temperature around the device is a function of the layout and construction of the PCB along with airflow across the surfaces. To ensure reliable operation, the maximum junction temperature of the device must be prevented from exceeding the maximum rating of 150°C ; with 80% derating, T_J would be limited to 120°C . Rearranging Equation 4 determines the board temperature required to maintain the junction temperature below 120°C :

$$T_{B,MAX} = T_J - P_{TOTAL} \cdot \Psi_{JB} \quad (8)$$

$$T_{B,MAX} = 120^\circ\text{C} - 0.54 \text{ W} \cdot 42^\circ\text{C/W} = 97^\circ\text{C} \quad (9)$$

Typical Application Diagrams

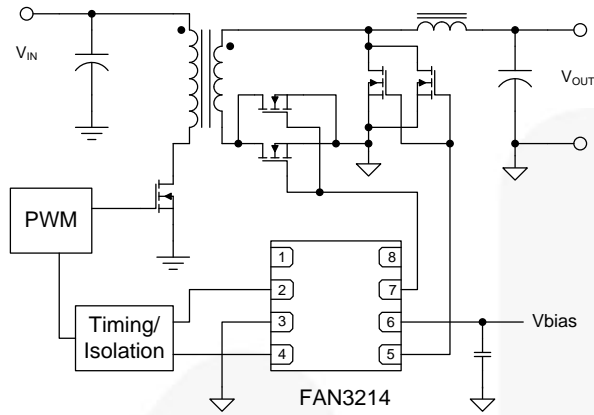

Figure 33. High-Current Forward Converter with Synchronous Rectification

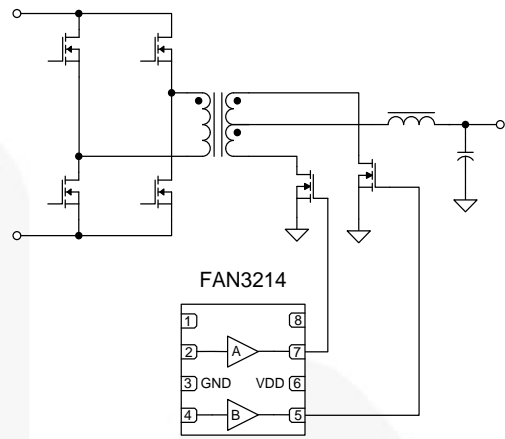

Figure 34. Center-Tapped Bridge Output with Synchronous Rectifiers

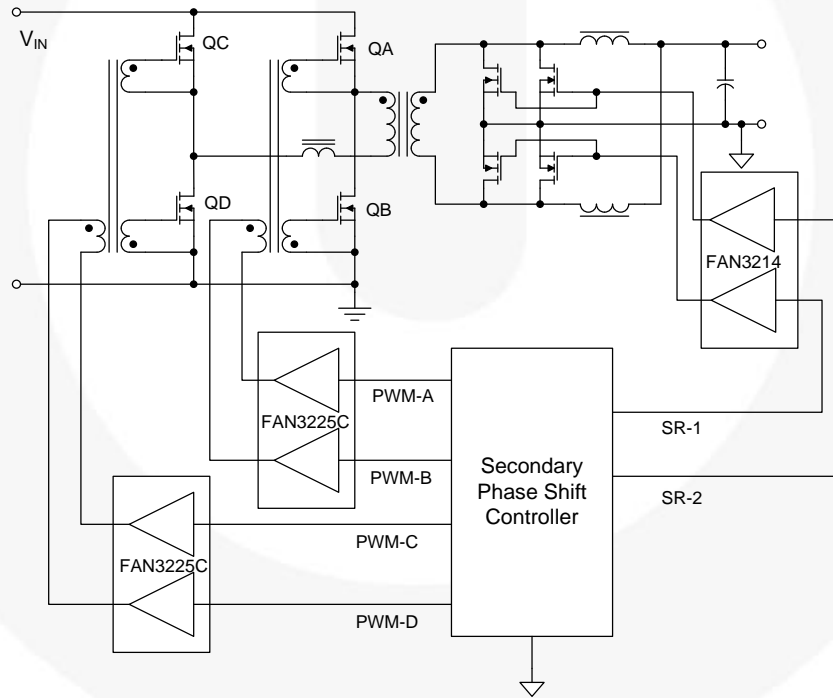

Figure 35. Secondary Controlled Full Bridge with Current Doubler Output, Synchronous Rectifiers (Simplified)

Table 1. Related Products

Type	Part Number	Gate Drive ⁽¹⁵⁾ (Sink/Src)	Input Threshold	Logic	Package
Single 1 A	FAN3111C	+1.1 A / -0.9 A	CMOS	Single Channel of Dual-Input/Single-Output	SOT23-5, MLP6
Single 1 A	FAN3111E	+1.1 A / -0.9 A	External ⁽¹⁶⁾	Single Non-Inverting Channel with External Reference	SOT23-5, MLP6
Single 2 A	FAN3100C	+2.5 A / -1.8 A	CMOS	Single Channel of Two-Input/One-Output	SOT23-5, MLP6
Single 2 A	FAN3100T	+2.5 A / -1.8 A	TTL	Single Channel of Two-Input/One-Output	SOT23-5, MLP6
Single 2 A	FAN3180	+2.4 A / -1.6 A	TTL	Single Non-Inverting Channel + 3.3 V LDO	SOT23-5
Dual 2 A	FAN3216T	+2.5 A / -1.8 A	TTL	Dual Inverting Channels	SOIC8
Dual 2 A	FAN3217T	+2.5 A / -1.8 A	TTL	Dual Non-Inverting Channels	SOIC8
Dual 2 A	FAN3226C	+2.4 A / -1.6 A	CMOS	Dual Inverting Channels + Dual Enable	SOIC8, MLP8
Dual 2 A	FAN3226T	+2.4 A / -1.6 A	TTL	Dual Inverting Channels + Dual Enable	SOIC8, MLP8
Dual 2 A	FAN3227C	+2.4 A / -1.6 A	CMOS	Dual Non-Inverting Channels + Dual Enable	SOIC8, MLP8
Dual 2 A	FAN3227T	+2.4 A / -1.6 A	TTL	Dual Non-Inverting Channels + Dual Enable	SOIC8, MLP8
Dual 2 A	FAN3228C	+2.4 A / -1.6 A	CMOS	Dual Channels of Two-Input/One-Output, Pin Config.1	SOIC8, MLP8
Dual 2 A	FAN3228T	+2.4 A / -1.6 A	TTL	Dual Channels of Two-Input/One-Output, Pin Config.1	SOIC8, MLP8
Dual 2 A	FAN3229C	+2.4 A / -1.6 A	CMOS	Dual Channels of Two-Input/One-Output, Pin Config.2	SOIC8, MLP8
Dual 2 A	FAN3229T	+2.4 A / -1.6 A	TTL	Dual Channels of Two-Input/One-Output, Pin Config.2	SOIC8, MLP8
Dual 2 A	FAN3268T	+2.4 A / -1.6 A	TTL	20 V Non-Inverting Channel (NMOS) and Inverting Channel (PMOS) + Dual Enables	SOIC8
Dual 2 A	FAN3278T	+2.4 A / -1.6 A	TTL	30 V Non-Inverting Channel (NMOS) and Inverting Channel (PMOS) + Dual Enables	SOIC8
Dual 4 A	FAN3213T	+2.5 A / -1.8 A	TTL	Dual Inverting Channels	SOIC8
Dual 4 A	FAN3214T	+2.5 A / -1.8 A	TTL	Dual Non-Inverting Channels	SOIC8
Dual 4 A	FAN3223C	+4.3 A / -2.8 A	CMOS	Dual Inverting Channels + Dual Enable	SOIC8, MLP8
Dual 4 A	FAN3223T	+4.3 A / -2.8 A	TTL	Dual Inverting Channels + Dual Enable	SOIC8, MLP8
Dual 4 A	FAN3224C	+4.3 A / -2.8 A	CMOS	Dual Non-Inverting Channels + Dual Enable	SOIC8, MLP8
Dual 4 A	FAN3224T	+4.3 A / -2.8 A	TTL	Dual Non-Inverting Channels + Dual Enable	SOIC8, MLP8
Dual 4 A	FAN3225C	+4.3 A / -2.8 A	CMOS	Dual Channels of Two-Input/One-Output	SOIC8, MLP8
Dual 4 A	FAN3225T	+4.3 A / -2.8 A	TTL	Dual Channels of Two-Input/One-Output	SOIC8, MLP8
Single 9 A	FAN3121C	+9.7 A / -7.1 A	CMOS	Single Inverting Channel + Enable	SOIC8, MLP8
Single 9 A	FAN3121T	+9.7 A / -7.1 A	TTL	Single Inverting Channel + Enable	SOIC8, MLP8
Single 9 A	FAN3122C	+9.7 A / -7.1 A	CMOS	Single Non-Inverting Channel + Enable	SOIC8, MLP8
Single 9 A	FAN3122T	+9.7 A / -7.1 A	TTL	Single Non-Inverting Channel + Enable	SOIC8, MLP8
Dual 12 A	FAN3240	+12.0 A	TTL	Dual-Coil Relay Driver, Timing Config. 0	SOIC8
Dual 12 A	FAN3241	+12.0 A	TTL	Dual-Coil Relay Driver, Timing Config. 1	SOIC8

Notes:15. Typical currents with OUTx at 6 V and V_{DD}=12 V.

16. Thresholds proportional to an externally supplied reference voltage.

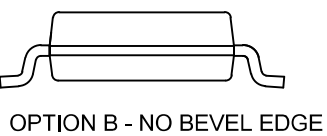
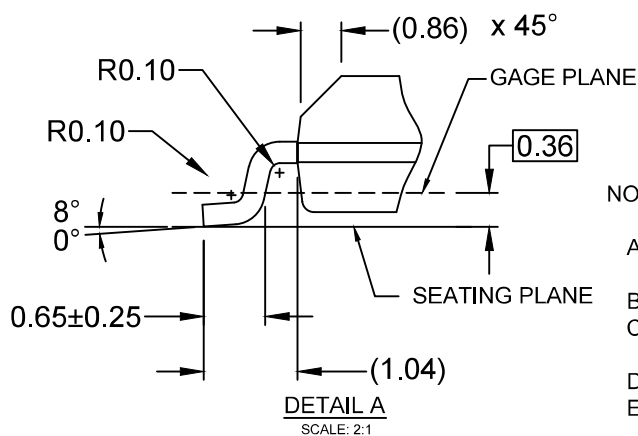
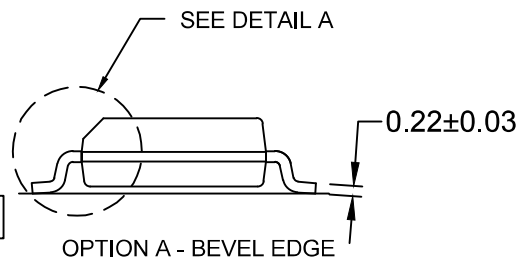
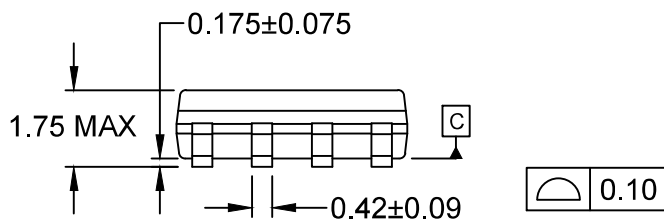
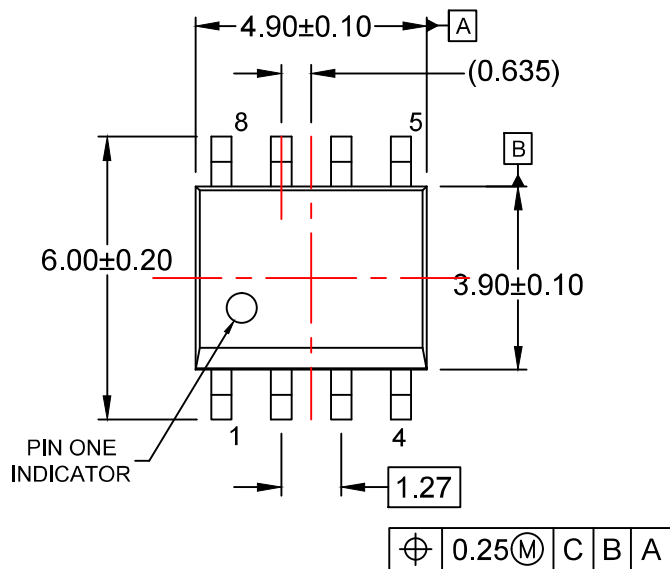

NOTES:

- A) THIS PACKAGE CONFORMS TO JEDEC MS-012, VARIATION AA.
- B) ALL DIMENSIONS ARE IN MILLIMETERS.
- C) DIMENSIONS DO NOT INCLUDE MOLD FLASH OR BURRS.
- D) LANDPATTERN STANDARD: SOIC127P600X175-8M
- E) DRAWING FILENAME: M08Arev16





TRADEMARKS

The following includes registered and unregistered trademarks and service marks, owned by Fairchild Semiconductor and/or its global subsidiaries, and is not intended to be an exhaustive list of all such trademarks.

- | | | | |
|--------------------------|--|---------------------------------------|------------------|
| AccuPower™ | F-PFS™ | OPTOPLANAR® | SYSTEM GENERAL® |
| AttitudeEngine™ | FRFET® | Power Supply WebDesigner™ | TinyBoost® |
| Awinda® | Global Power Resource SM | PowerTrench® | TinyBuck® |
| AX-CAP®* | GreenBridge™ | PowerXS™ | TinyCalc™ |
| BitSiC™ | Green FPS™ | Programmable Active Droop™ | TinyLogic® |
| Build it Now™ | Green FPS™ e-Series™ | QFET® | TINYOPTO™ |
| CorePLUS™ | Gmax™ | QS™ | TinyPower™ |
| CorePOWER™ | GTO™ | Quiet Series™ | TinyPWM™ |
| CROSSVOL™ | IntelliMAX™ | RapidConfigure™ | TinyWire™ |
| CTL™ | ISOPLANAR™ | Saving our world, 1mW/W/kW at a time™ | TranSiC™ |
| Current Transfer Logic™ | Making Small Speakers Sound Louder and Better™ | SignalWise™ | TriFault Detect™ |
| DEUXPEED® | MegaBuck™ | SmartMax™ | TRUECURRENT®* |
| Dual Cool™ | MICROCOUPLER™ | SMART START™ | μSerDes™ |
| EcoSPARK® | MicroFET™ | Solutions for Your Success™ | UHC® |
| EfficientMax™ | MicroPak™ | SPM® | Ultra FRFET™ |
| ESBC™ | MicroPak2™ | STEALTH™ | UniFET™ |
| F [®] | MillerDrive™ | SuperFET® | Vcx™ |
| Fairchild® | MotionMax™ | SuperSOT™-3 | VisualMax™ |
| Fairchild Semiconductor® | MotionGrid® | SuperSOT™-6 | VoltagePlus™ |
| FACT Quiet Series™ | MTi® | SuperSOT™-8 | Xs™ |
| FACT® | MTx® | SupreMOS® | Xsens™ |
| FastvCore™ | MVN® | SyncFET™ | 仙童® |
| FETBench™ | mWSaver® | Sync-Lock™ | |
| FPS™ | OptoHiT™ | | |
| | OPTOLOGIC® | | |

* Trademarks of System General Corporation, used under license by Fairchild Semiconductor.

DISCLAIMER

FAIRCHILD SEMICONDUCTOR RESERVES THE RIGHT TO MAKE CHANGES WITHOUT FURTHER NOTICE TO ANY PRODUCTS HEREIN TO IMPROVE RELIABILITY, FUNCTION, OR DESIGN. TO OBTAIN THE LATEST, MOST UP-TO-DATE DATASHEET AND PRODUCT INFORMATION, VISIT OUR WEBSITE AT [HTTP://WWW.FAIRCHILDSEMI.COM](http://www.fairchildsemi.com). FAIRCHILD DOES NOT ASSUME ANY LIABILITY ARISING OUT OF THE APPLICATION OR USE OF ANY PRODUCT OR CIRCUIT DESCRIBED HEREIN; NEITHER DOES IT CONVEY ANY LICENSE UNDER ITS PATENT RIGHTS, NOR THE RIGHTS OF OTHERS. THESE SPECIFICATIONS DO NOT EXPAND THE TERMS OF FAIRCHILD'S WORLDWIDE TERMS AND CONDITIONS, SPECIFICALLY THE WARRANTY THEREIN, WHICH COVERS THESE PRODUCTS.

AUTHORIZED USE

Unless otherwise specified in this data sheet, this product is a standard commercial product and is not intended for use in applications that require extraordinary levels of quality and reliability. This product may not be used in the following applications, unless specifically approved in writing by a Fairchild officer: (1) automotive or other transportation, (2) military/aerospace, (3) any safety critical application – including life critical medical equipment – where the failure of the Fairchild product reasonably would be expected to result in personal injury, death or property damage. Customer's use of this product is subject to agreement of this Authorized Use policy. In the event of an unauthorized use of Fairchild's product, Fairchild accepts no liability in the event of product failure. In other respects, this product shall be subject to Fairchild's Worldwide Terms and Conditions of Sale, unless a separate agreement has been signed by both Parties.

ANTI-COUNTERFEITING POLICY

Fairchild Semiconductor Corporation's Anti-Counterfeiting Policy. Fairchild's Anti-Counterfeiting Policy is also stated on our external website, www.fairchildsemi.com, under Terms of Use

Counterfeiting of semiconductor parts is a growing problem in the industry. All manufacturers of semiconductor products are experiencing counterfeiting of their parts. Customers who inadvertently purchase counterfeit parts experience many problems such as loss of brand reputation, substandard performance, failed applications, and increased cost of production and manufacturing delays. Fairchild is taking strong measures to protect ourselves and our customers from the proliferation of counterfeit parts. Fairchild strongly encourages customers to purchase Fairchild parts either directly from Fairchild or from Authorized Fairchild Distributors who are listed by country on our web page cited above. Products customers buy either from Fairchild directly or from Authorized Fairchild Distributors are genuine parts, have full traceability, meet Fairchild's quality standards for handling and storage and provide access to Fairchild's full range of up-to-date technical and product information. Fairchild and our Authorized Distributors will stand behind all warranties and will appropriately address any warranty issues that may arise. Fairchild will not provide any warranty coverage or other assistance for parts bought from Unauthorized Sources. Fairchild is committed to combat this global problem and encourage our customers to do their part in stopping this practice by buying direct or from authorized distributors.

PRODUCT STATUS DEFINITIONS

Definition of Terms

Datasheet Identification	Product Status	Definition
Advance Information	Formative / In Design	Datasheet contains the design specifications for product development. Specifications may change in any manner without notice.
Preliminary	First Production	Datasheet contains preliminary data; supplementary data will be published at a later date. Fairchild Semiconductor reserves the right to make changes at any time without notice to improve design.
No Identification Needed	Full Production	Datasheet contains final specifications. Fairchild Semiconductor reserves the right to make changes at any time without notice to improve the design.
Obsolete	Not In Production	Datasheet contains specifications on a product that is discontinued by Fairchild Semiconductor. The datasheet is for reference information only.