

April 1995

8A, 700V - 1000V Hyperfast Diodes

Features

- Hyperfast with Soft Recovery <60ns
- Operating Temperature +175°C
- Reverse Voltage Up To 1000V
- Avalanche Energy Rated
- Planar Construction

Applications

- Switching Power Supplies
- Power Switching Circuits
- General Purpose

Description

RHRP870, RHRP880, RHRP890 and RHRP8100 (TA49060) are hyperfast diodes with soft recovery characteristics ($t_{RR} < 60\text{ns}$). They have half the recovery time of ultrafast diodes and are silicon nitride passivated ion-implanted epitaxial planar construction.

These devices are intended for use as freewheeling/clamping diodes and rectifiers in a variety of switching power supplies and other power switching applications. Their low stored charge and hyperfast soft recovery minimize ringing and electrical noise in many power switching circuits reducing power loss in the switching transistors.

PACKAGING AVAILABILITY

PART NUMBER	PACKAGE	BRAND
RHRP870	TO-220AC	RHRP870
RHRP880	TO-220AC	RHRP880
RHRP890	TO-220AC	RHRP890
RHRP8100	TO-220AC	RHRP8100

NOTE: When ordering, use the entire part number.

Package

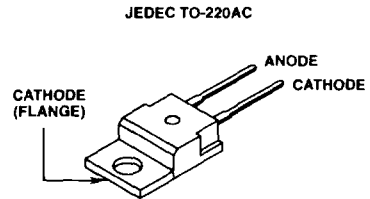

Symbol



Absolute Maximum Ratings $T_C = +25^\circ\text{C}$, Unless Otherwise Specified

	RHRP870	RHRP880	RHRP890	RHRP8100	UNITS
Peak Repetitive Reverse Voltage V_{RRM}	700	800	900	1000	V
Working Peak Reverse Voltage V_{RWM}	700	800	900	1000	V
DC Blocking Voltage V_R	700	800	900	1000	V
Average Rectified Forward Current $I_{F(AV)}$ ($T_C = +140^\circ\text{C}$)	8	8	8	8	A
Repetitive Peak Surge Current I_{FSM} (Square Wave, 20kHz)	16	16	16	16	A
Nonrepetitive Peak Surge Current I_{FSM} (Halfwave, 1 Phase, 60Hz)	100	100	100	100	A
Maximum Power Dissipation P_D	75	75	75	75	W
Avalanche Energy ($L = 40\text{mH}$) E_{AVL}	20	20	20	20	mj
Operating and Storage Temperature T_{STG}, T_J	-65 to +175	-65 to +175	-65 to +175	-65 to +175	°C

Specifications RHRP870, RHRP880, RHRP890, RHRP8100

Electrical Specifications $T_C = +25^\circ\text{C}$, Unless Otherwise Specified

SYMBOL	TEST CONDITION	RHRP870			RHRP880			RHRP890			RHRP8100			UNITS
		MIN	TYP	MAX	MIN	TYP	MAX	MIN	TYP	MAX	MIN	TYP	MAX	
V_F	$I_F = 8\text{A}, T_C = +25^\circ\text{C}$	-	-	3.0	-	-	3.0	-	-	3.0	-	-	3.0	V
	$I_F = 8\text{A}, T_C = +150^\circ\text{C}$	-	-	2.5	-	-	2.5	-	-	2.5	-	-	2.5	V
I_R	$V_R = 700\text{V}, T_C = +25^\circ\text{C}$	-	-	100	-	-	-	-	-	-	-	-	-	μA
	$V_R = 800\text{V}, T_C = +25^\circ\text{C}$	-	-	-	-	-	100	-	-	-	-	-	-	μA
	$V_R = 900\text{V}, T_C = +25^\circ\text{C}$	-	-	-	-	-	-	-	-	100	-	-	-	μA
	$V_R = 1000\text{V}, T_C = +25^\circ\text{C}$	-	-	-	-	-	-	-	-	-	-	-	100	μA
I_R	$V_R = 700\text{V}, T_C = +150^\circ\text{C}$	-	-	500	-	-	-	-	-	-	-	-	-	μA
	$V_R = 800\text{V}, T_C = +150^\circ\text{C}$	-	-	-	-	-	500	-	-	-	-	-	-	μA
	$V_R = 900\text{V}, T_C = +150^\circ\text{C}$	-	-	-	-	-	-	-	-	500	-	-	-	μA
	$V_R = 1000\text{V}, T_C = +150^\circ\text{C}$	-	-	-	-	-	-	-	-	-	-	-	500	μA
t_{RR}	$I_F = 1\text{A}, di_F/dt = 100\text{A}/\mu\text{s}$	-	-	60	-	-	60	-	-	60	-	-	60	ns
	$I_F = 8\text{A}, di_F/dt = 100\text{A}/\mu\text{s}$	-	-	65	-	-	65	-	-	65	-	-	65	ns
t_A	$I_F = 8\text{A}, di_F/dt = 100\text{A}/\mu\text{s}$	-	38	-	-	38	-	-	38	-	-	38	-	ns
t_B	$I_F = 8\text{A}, di_F/dt = 100\text{A}/\mu\text{s}$	-	21	-	-	21	-	-	21	-	-	21	-	ns
Q_{RR}	$I_F = 8\text{A}, di_F/dt = 100\text{A}/\mu\text{s}$	-	130	-	-	130	-	-	130	-	-	130	-	nC
C_J	$V_R = 10\text{V}, I_F = 0\text{A}$	-	30	-	-	30	-	-	30	-	-	30	-	pF
R_{BJC}		-	-	2.0	-	-	2.0	-	-	2.0	-	-	2.0	$^\circ\text{C}/\text{W}$

DEFINITIONS

V_F = Instantaneous forward voltage ($p_w = 300\mu\text{s}$, $D = 2\%$).

I_R = Instantaneous reverse current.

t_{RR} = Reverse recovery time (Figure 2), summation of $t_A + t_B$.

t_A = Time to reach peak reverse current (See Figure 2).

t_B = Time from peak I_{RM} to projected zero crossing of I_{RM} based on a straight line from peak I_{RM} through 25% of I_{RM} (See Figure 2).

R_{BJC} = Thermal resistance junction to case.

E_{AVL} = Controlled avalanche energy (See Figure 10 and Figure 11).

p_w = pulse width.

D = duty cycle.

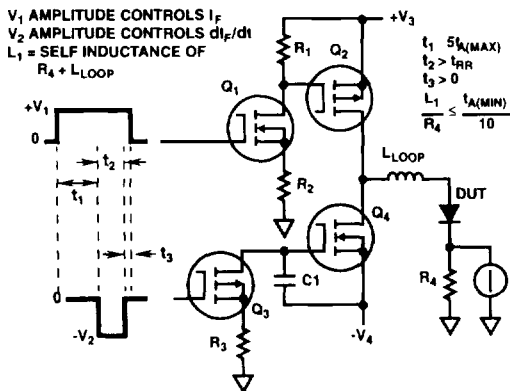

FIGURE 1. t_{RR} TEST CIRCUIT

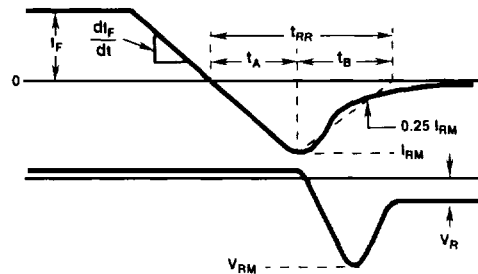

FIGURE 2. t_{RR} WAVEFORMS AND DEFINITIONS

Typical Performance Curves

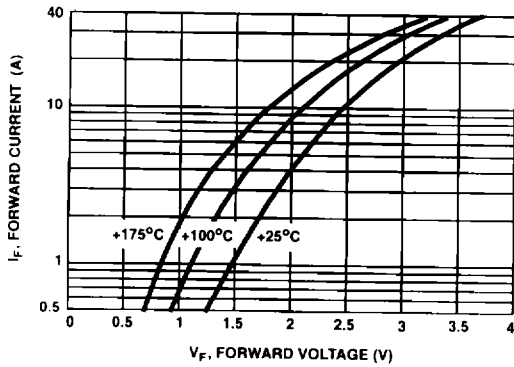

FIGURE 3. TYPICAL FORWARD CURRENT vs FORWARD VOLTAGE DROP

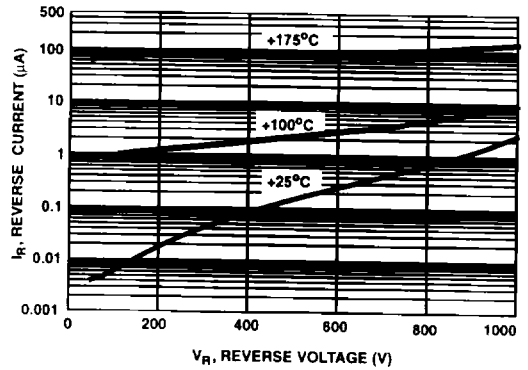

FIGURE 4. TYPICAL REVERSE CURRENT vs REVERSE VOLTAGE

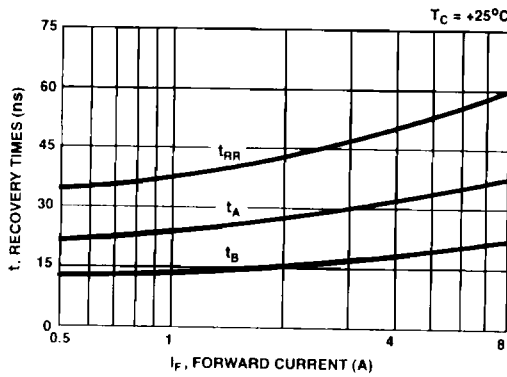

FIGURE 5. TYPICAL t_{RR} , t_A AND t_B CURVES vs FORWARD CURRENT AT +25°C

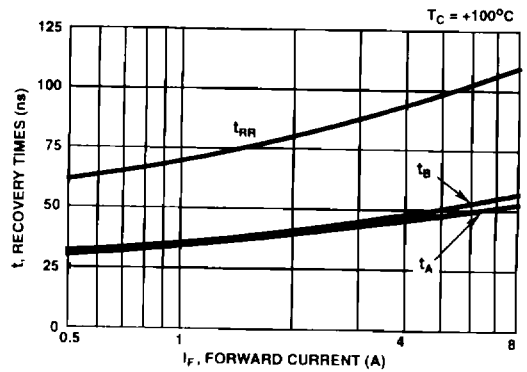

FIGURE 6. TYPICAL t_{RR} , t_A AND t_B CURVES vs FORWARD CURRENT AT +100°C

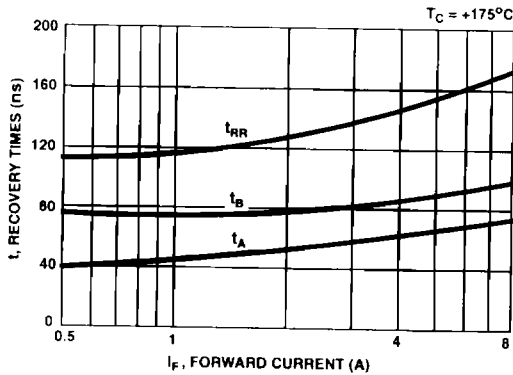

FIGURE 7. TYPICAL t_{RR} , t_A AND t_B CURVES vs FORWARD CURRENT AT +175°C

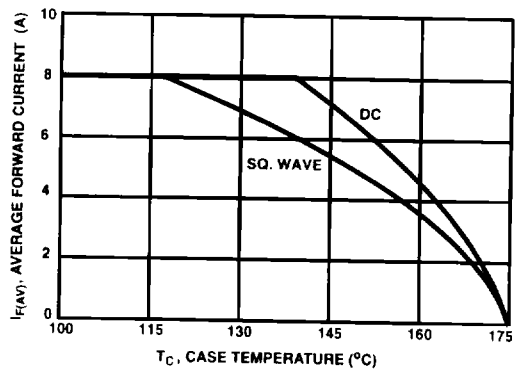

FIGURE 8. CURRENT DERATING CURVE FOR ALL TYPES

Typical Performance Curves (Continued)

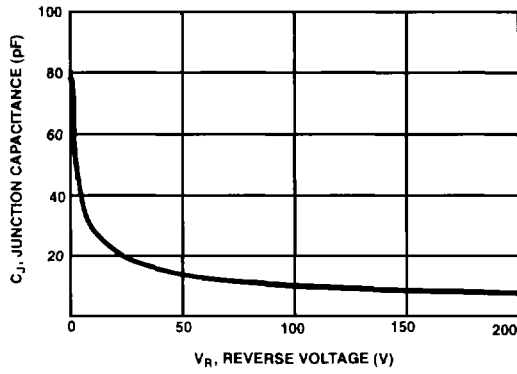

FIGURE 9. TYPICAL JUNCTION CAPACITANCE vs REVERSE VOLTAGE

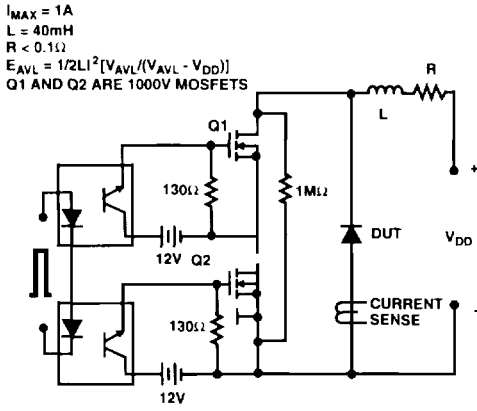

FIGURE 10. AVALANCHE ENERGY TEST CIRCUIT

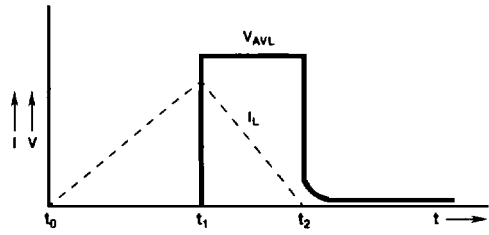

FIGURE 11. AVALANCHE CURRENT AND VOLTAGE WAVEFORMS