

T-51-17

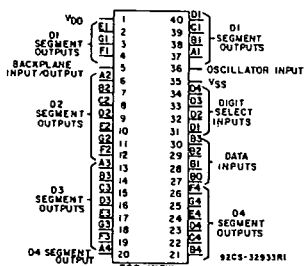

CD7211, CD7211A Types



TOP VIEW
TERMINAL ASSIGNMENT
CD7211, CD7211A

CMOS Four-Digit LCD Decoders-Drivers

6-V Rating

Features:

- 6-V supply-voltage rating
- No external components necessary
- 4-digit segment drive capability
- Backplane input/output allows synchronization for cascading devices to drive more digits
- Decodes multiplexed binary to hexadecimal (CD7211) and decimal (CD7211A) outputs

Applications:

- Digital meters and calculators
- General-purpose displays
- Wall and table clocks
- Automobile dashboard displays
- Appliance control panels

■ CD7211 and CD7211A are non-multiplexed, four-digit, seven-segment, liquid-crystal display decoder-drivers.

They contain all the circuitry necessary to drive conventional LCD displays (no external components required). Outputs are four sets of seven-segment driver signals and a backplane driver signal. The backplane signal, derived from an on-board free-running oscillator, is common to all four-digit displays.

The backplane and segment drives are designed so that p and n channels have the same ON resistance and thus equal rise and fall times. This equality eliminates any DC component, thereby maximizing display life. In addition to feeding the internal display drivers, the backplane signal can also be used as a master to drive a number of slave devices. The number of slaved devices should be limited to the load that keeps the backplane rise and fall times from exceeding 5 μ s. If this limit is to be exceeded the master backplane drivers should be disabled (by connecting pin 36, the oscillator input, to V_{SS}) and pin 5 should be fed from an external oscillator and all devices slaved to it. The maximum frequency of the external signal should be 125 MHz at room temperatures.

The on-board oscillator, which operates at 16 kHz when free-running (pin 36 floating), provides a backplane signal whose frequency is approximately 125 Hz. This frequency can be reduced by connecting an external capacitor to pin 36. Plots of backplane frequency vs. supply voltage at various values of external capacitance are shown in Fig. 3. The oscillator may be overdriven by an external signal but care must be taken to keep the lower voltage level above V_{SS} by at least 20 per cent of V_{DD} (for V_{DD}=5 V the signal should

oscillate between +1 and +5 volts). This precaution prevents the backplane driver from being disabled, a condition that would present a DC component to the LCD display. A signal swinging from rail-to-rail can also be used to overdrive the oscillator but in this case the duty cycle should be such that the lower portion of the signal must be less than one-microsecond duration (the backplane disable sensing circuit will not respond to signals of this duration).

There are four data inputs and four digit-select inputs. The four-bit binary input is decoded by means of a PROM into seven-segment hexadecimal outputs for the CD7211 and into decimal seven-segment display outputs for the CD7211A. These devices are pin-compatible with the Intersil ICM7211 and ICM7211A, respectively.

The CD7211 types are supplied in the 40-lead dual-in-line plastic (E suffix) package.



File Number 1725

CD7211, CD7211A Types

T-51-17

MAXIMUM RATINGS, Absolute-Maximum Values:

DC SUPPLY-VOLTAGE RANGE, (V_{DD}) -0.3 to +6.5 V
 (Voltages referenced to V_{SS} Terminal)

INPUT VOLTAGE RANGE, ALL INPUTS -0.3 to $V_{DD} + 0.3$ V

DC INPUT CURRENT, ANY ONE INPUT* ± 10 mA

POWER DISSIPATION PER PACKAGE (P_D):

For $T_A = -20$ to $+60^\circ\text{C}$ 500 mW

For $T_A = +60$ to $+70^\circ\text{C}$ Derate Linearly at 12 mW/ $^\circ\text{C}$ to 380 mW

DEVICE DISSIPATION PER OUTPUT TRANSISTOR

FOR $T_A = \text{FULL PACKAGE-TEMPERATURE RANGE}$ 100 mW

OPERATING-TEMPERATURE RANGE (T_A) -20 to $+70^\circ\text{C}$

STORAGE TEMPERATURE RANGE (T_{stg}) -55 to $+125^\circ\text{C}$

LEAD TEMPERATURE (DURING SOLDERING):

At distance $1/16 \pm 1/32$ in. (1.59 ± 0.79 mm) from case for 10 s max. $+265^\circ\text{C}$

*Pin 36 limited to ± 5 mA.

STATIC ELECTRICAL CHARACTERISTICS

$T_A = 25^\circ\text{C}$, $V_{DD} = 5$ V, $V_{SS} = 0$ V

CHARACTERISTIC	SYMBOL	CONDITIONS	LIMITS			UNITS
			MIN.	TYP.	MAX.	
Operating Supply Voltage Range	V_{DD}	$V_{SS} = 0$ V	3	5	6	V
Operating Current	I_{OP}	Display Operating	—	10	50	μA
Oscillator Input Current	I_{OL} , I_{OH}	Pin 36	—	± 2	± 10	μA
Segment Rise and Fall Time	t_{r} , t_{f}	$C_L = 200$ pF	—	0.5	—	μs
Backplane Rise and Fall Time	t_{rB} , t_{fB}	$C_L = 5000$ pF	—	1.5	—	μs
Oscillator Frequency	f_{OSC}	Pin 36 Floating	—	16	—	kHz
Backplane Frequency	f_{BP}	Pin 36 Floating	—	125	—	Hz
Input High Voltage	V_{IH}		3.5	—	—	V
Input Low Voltage	V_{IL}		—	—	1.5	V
Input Leakage Current	I_{IL}	Pins 27-34	—	± 0.01	± 1	μA
Input Capacitance	C_I	Pins 27-34	—	5	—	pF
Backplane Input Leakage	I_{ILBP1}	Pin 5 with Pin 36 @ V_{SS}	—	± 0.01	± 1	μA
Backplane Input Capacitance	C_{IBP1}		—	200	—	pF

DYNAMIC ELECTRICAL CHARACTERISTICS

$T_A = 25^\circ\text{C}$, $V_{DD} = 5$ V, $V_{SS} = 0$ V

CHARACTERISTIC	SYMBOL	CONDITIONS	TYP. VALUES	UNITS
Digit-Select Active Pulse Width	t_{sa}	See Timing Diagram	0.5	μs
Data Setup Time	t_{ds}	See Timing Diagram	250	ns
Data Hold Time	t_{dh}	See Timing Diagram	100	ns
Inter-Digit Select Time	t_{ids}	See Timing Diagram	1	μs

T-51-17

CD7211, CD7211A Types

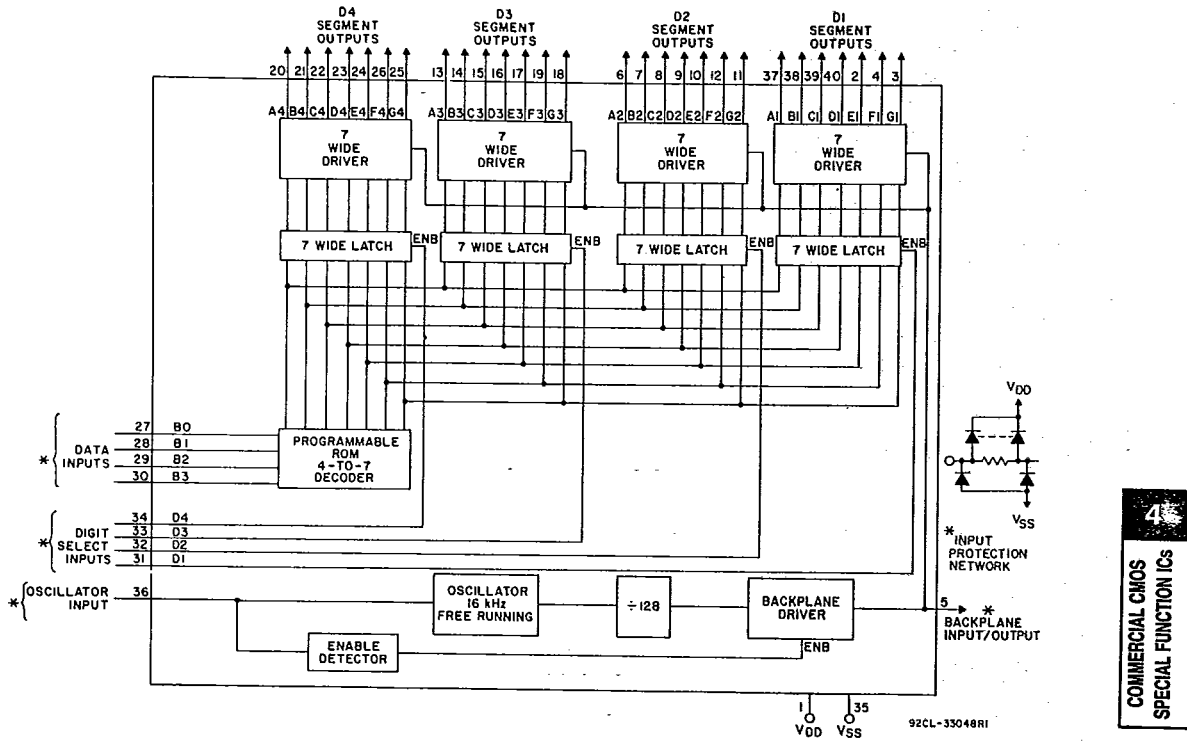

Fig. 1 - Block diagram of CD7211 and CD7211A.

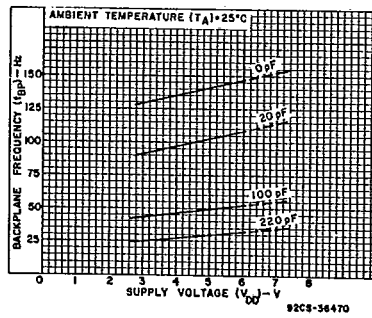
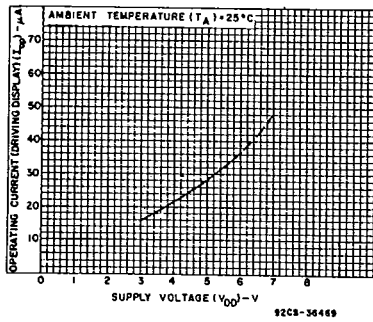
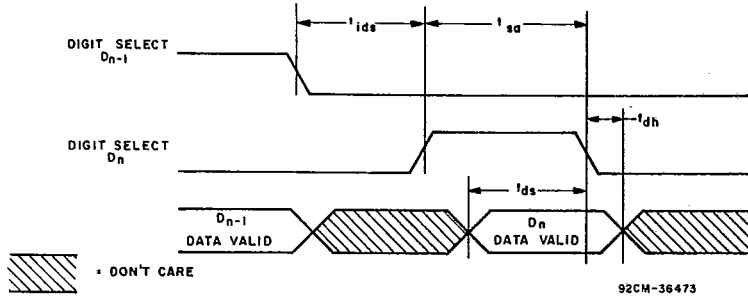

Fig. 2 - Typical operating current as a function of supply voltage.

Fig. 3 - Typical backplane frequency as a function of supply voltage and external capacitance on pin 36.

CD7211, CD7211A Types

T-51-17



92CM-36473

Fig. 4 - CD7211, CD7211A timing diagram.

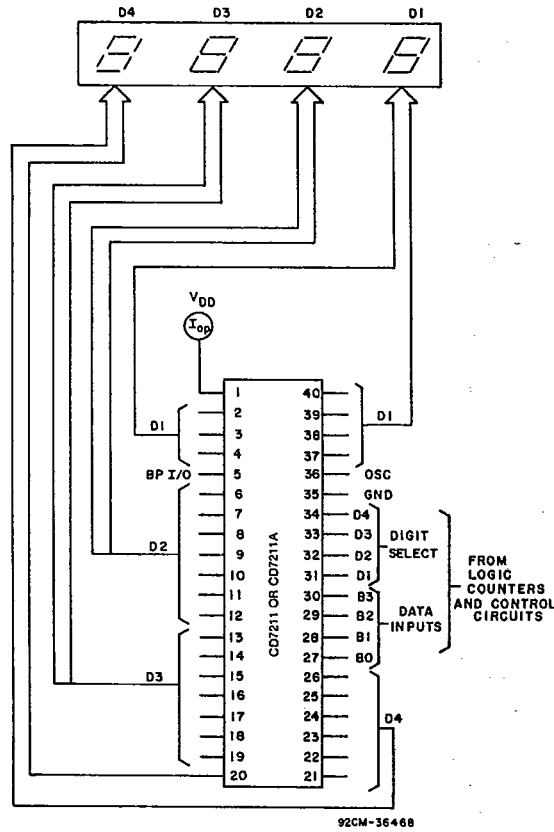

92CM-36468

Fig. 5 - Test circuit.

CD7211, CD7211A Types

T-51-17

Table I — Output Codes

Binary Input B3 B2 B1 B0	Display	
	Hexadecimal CD7211	Decimal CD7211A
0 0 0 0	0	0
0 0 0 1	1	1
0 0 1 0	2	2
0 0 1 1	3	3
0 1 0 0	4	4
0 1 0 1	5	5
0 1 1 0	6	6
0 1 1 1	7	7
1 0 0 0	8	8
1 0 0 1	9	9
1 0 1 0	A	-
1 0 1 1	B	E
1 1 0 0	C	H
1 1 0 1	D	L
1 1 1 0	E	P
1 1 1 1	F	(BLANK)

92CS-33050

DIGIT SELECTION TRUTH TABLE

Pins				Digit Selected
31	32	33	34	
1	0	0	0	D1 (LSD)
0	1	0	0	D2
0	0	1	0	D3
0	0	0	1	D4 (MSD)

DISPLAY SEGMENTS

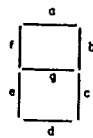

92CS-31376

4
COMMERCIAL CMOS
SPECIAL FUNCTION ICs

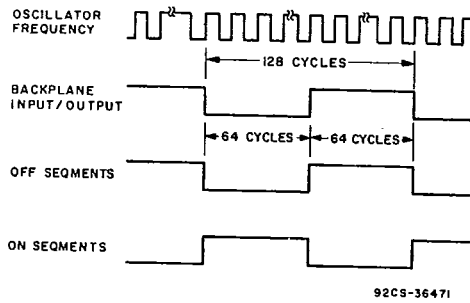

92CS-36471

Fig. 6 - Display waveforms.