

SMPTE 292M/259M Digital Video Deserializer / Descrambler with Video and Ancillary Data FIFOs

General Description

The CLC031A SMPTE 292M / 259M Digital Video Deserializer/Descrambler with Video and Ancillary Data FIFOs is a monolithic integrated circuit that deserializes and decodes SMPTE 292M, 1.485Gbps (or 1.483Gbps) serial component video data, to 20-bit parallel data with a synchronized parallel word-rate clock. It also deserializes and decodes SMPTE 259M, 270Mbps, 360Mbps and SMPTE 344M (proposed) 540Mbps serial component video data, to 10-bit parallel data. Functions performed by the CLC031A include: clock/data recovery from the serial data, serial-to-parallel data conversion, SMPTE standard data decoding, NRZI-to-NRZ conversion, parallel data clock generation, word framing, CRC and EDH data checking and handling, Ancillary Data extraction and automatic video format determination. The parallel video output features a variable-depth FIFO which can be adjusted to delay the output data up to 4 parallel data clock periods. Ancillary Data may be selectively extracted from the parallel data through the use of masking and control bits in the configuration and control registers and stored in the on-chip FIFO. Reverse LSB dithering is also implemented.

The unique multi-functional I/O port of the CLC031A provides external access to functions and data stored in the configuration and control registers. This feature allows the designer greater flexibility in tailoring the CLC031A to the desired application. The CLC031A is auto-configured to a default operating condition at power-on or after a reset command. Separate power pins for the PLL, deserializer and other functional circuits improve power supply rejection and noise performance.

The CLC031A has a unique Built-In Self-Test (BIST) and video Test Pattern Generator (TPG). The BIST enables comprehensive testing of the device by the user. The BIST uses the TPG as input data and includes SD and HD component video test patterns, reference black, PLL and EQ pathologicals and a 75% saturation, 8 vertical colour bar pattern, for all implemented rasters. The colour bar pattern has optional transition coding at changes in the chroma and luma bar data. The TPG data is output via the parallel data port.

The CLC030, SMPTE 292M / 259M Digital Video Serializer with Ancillary Data FIFO and Integrated Cable Driver, is the ideal complement to the CLC031A.

The CLC031A's internal circuitry is powered from +2.5 Volts and the I/O circuitry from a +3.3 Volt supply. Power dissipation is typically 850mW. The device is packaged in a 64-pin TQFP.

Features

- SDTV/HDTV serial digital video standard compliant
 - Supports 270 Mbps, 360 Mbps, 540 Mbps, 1.483 Gbps and 1.485 Gbps serial video data rates with auto-detection
 - LSB de-dithering option
 - Uses low-cost 27MHz crystal or clock oscillator reference
 - Fast VCO lock time: < 500 μ s at 1.485 Gbps
 - Built-in self-test (BIST) and video test pattern generator (TPG)*
 - Automatic EDH/CRC word and flag processing
 - Ancillary Data FIFO with extensive packet handling options
 - Adjustable, 4-deep parallel output video data FIFO
 - Flexible control and configuration I/O port
 - LVCMOS compatible control inputs and clock and data outputs
 - LVDS and ECL-compatible, differential, serial inputs
 - 3.3V I/O power supply and 2.5V logic power supply operation
 - Low power: typically 850mW
 - 64-pin TQFP package
 - Commercial temperature range 0°C to +70°C
- * Patent applications made or pending.

Applications

- SDTV/HDTV serial-to-parallel digital video interfaces for:
 - Video editing equipment
 - VTRs
 - Standards converters
 - Digital video routers and switchers
 - Digital video processing and editing equipment
 - Video test pattern generators and digital video test equipment
 - Video signal generators

Ordering Information

Order Number	Package Type	NS Package Number
CLC031AVEC	64-Pin TQFP	VEC-64A

Typical Application

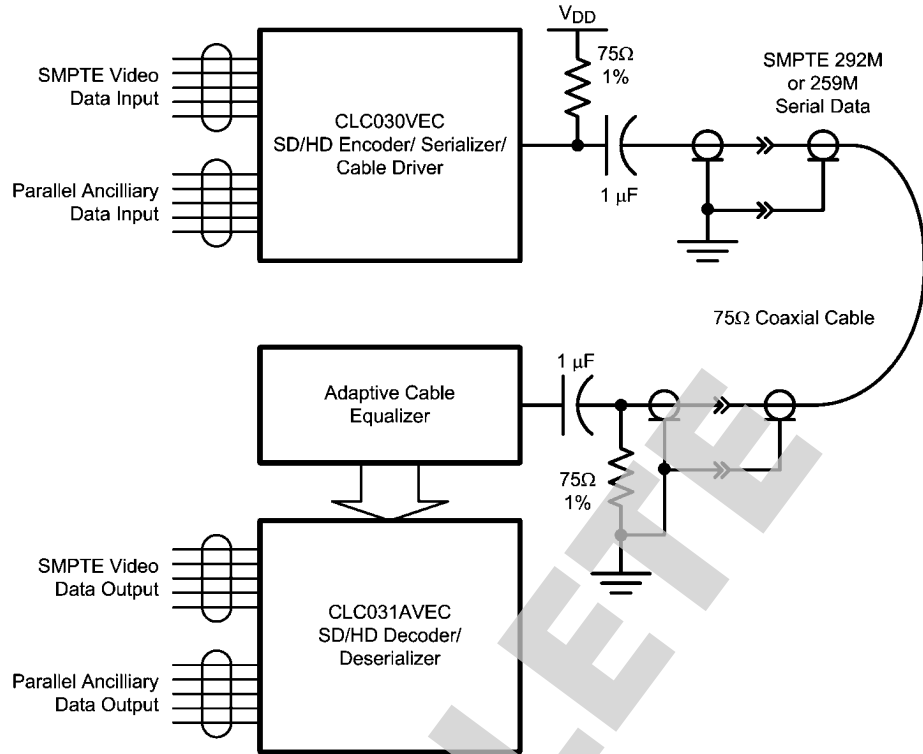

20020101

OBSOLETE

Block Diagram

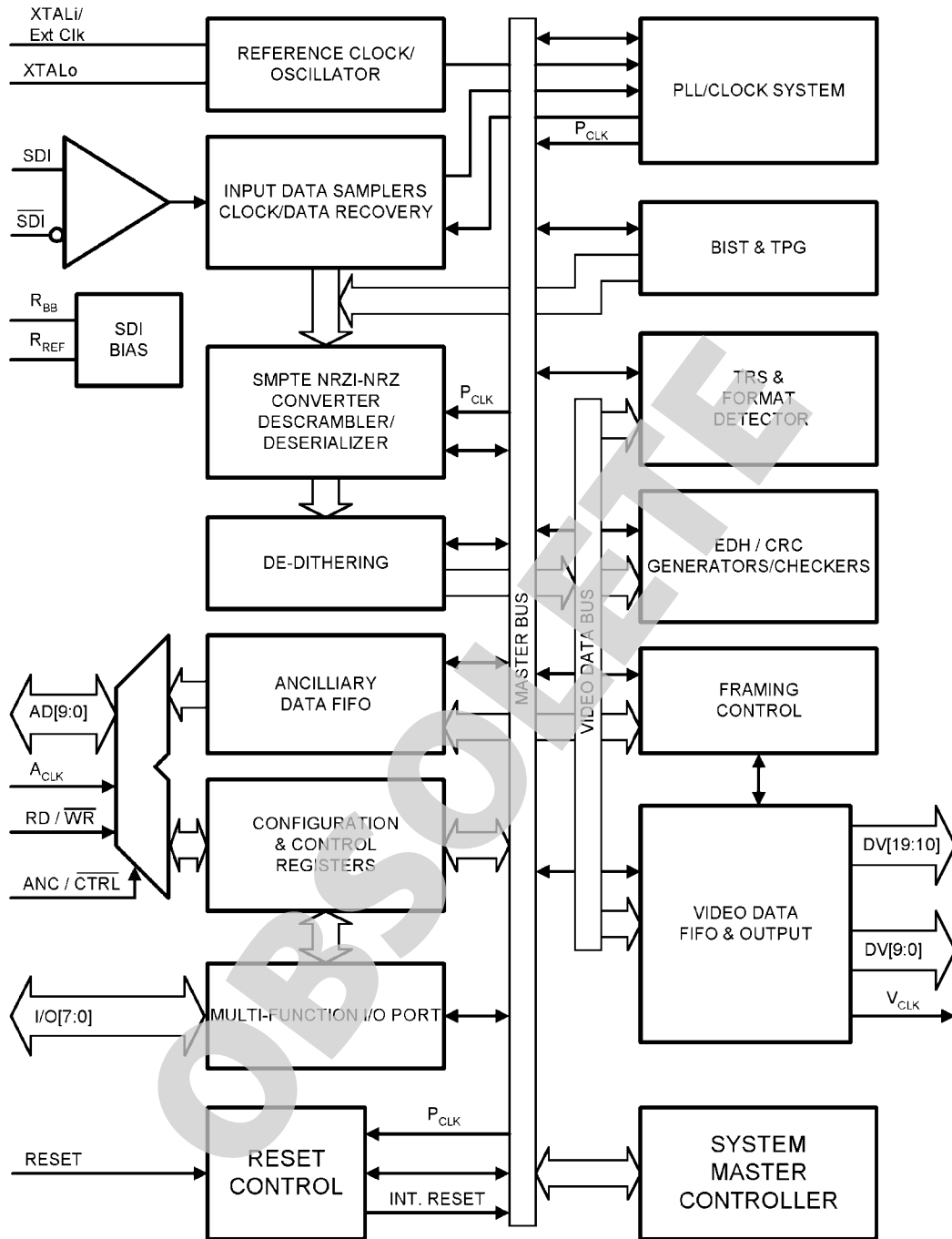

20020102

Connection Diagram

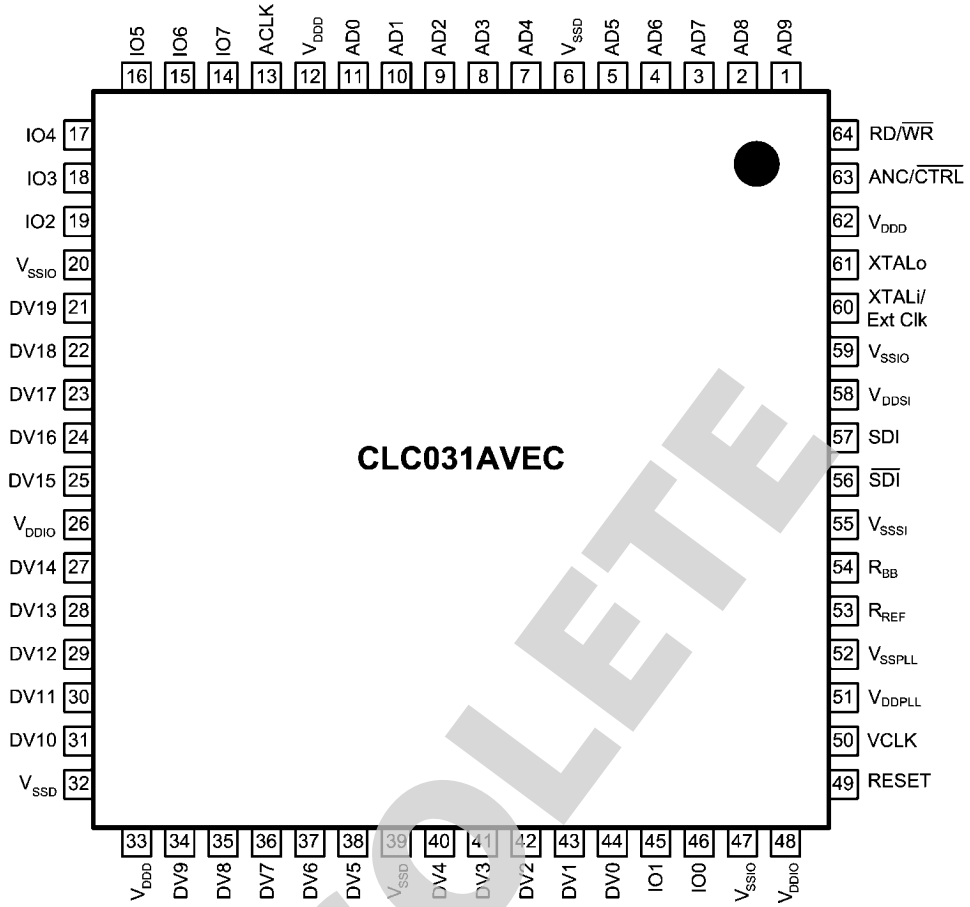

64-Pin TQFP
Order Number CLC031AVEC
See NS Package Number VEC-64A

20020103

Absolute Maximum Ratings (Note 1)

It is anticipated that this device will not be offered in a military qualified version. If Military/Aerospace specified devices are required, please contact the National Semiconductor Sales Office / Distributors for availability and specifications.

CMOS I/O Supply Voltage ($V_{DDIO}-V_{SSIO}$):	4.0V
SDI Supply Voltage ($V_{DDSI}-V_{SSSI}$):	4.0V
Digital Logic Supply Voltage ($V_{DD}-V_{SSD}$):	3.0V
PLL Supply Voltage ($V_{DDPLL}-V_{SSPLL}$):	3.0V
CMOS Input Voltage (V_i):	$V_{SSIO} - 0.15V$ to $V_{DDIO} + 0.15V$
CMOS Output Voltage (V_o):	$V_{SSIO} - 0.15V$ to $V_{DDIO} + 0.15V$

CMOS Input Current (single input):	
$V_i = V_{SSIO} - 0.15V$:	-5 mA
$V_i = V_{DDIO} + 0.15V$:	+5 mA
CMOS Output Source/Sink Current:	± 6 mA
I_{BB} Output Current:	+300 μ A
I_{REF} Output Current:	+300 μ A
SDI Input Voltage (V_i):	$V_{SSSI} - 0.15V$ to $V_{DDSI} + 0.15V$
Package Thermal Resistance	
θ_{JA} @ 0 LFM Airflow	40.1°C/W
θ_{JA} @ 500 LFM Airflow	24.5°C/W
θ_{JC}	5.23°C/W
Storage Temp. Range:	-65°C to +150°C
Junction Temperature:	+150°C
Lead Temperature (Soldering 4 Sec):	+260°C
ESD Rating (HBM):	6.0 kV
ESD Rating (MM):	400 V

Recommended Operating Conditions

Symbol	Parameter	Conditions	Reference	Min	Typ	Max	Units
V_{DDIO}	CMOS I/O Supply Voltage	$V_{DDIO}-V_{SSIO}$		3.150	3.300	3.450	V
V_{DDSD}	SDI Supply Voltage	$V_{DDSI}-V_{SSSI}$					
V_{DDD}	Digital Logic Supply Voltage	$V_{DD}-V_{SSD}$		2.375	2.500	2.625	V
V_{DDPLL}	PLL Supply Voltage	$V_{DDPLL}-V_{SSPLL}$					
T_A	Operating Free Air Temperature			0		+70	°C

Required Input Conditions

(Note 9)

Symbol	Parameter	Conditions	Reference	Min	Typ	Max	Units
V_{IN}	Input Voltage Range		All LVCMOS Inputs	V_{SSIO}		V_{DDIO}	V
t_r, t_f	Rise Time, Fall Time	10%–90%		1.0	1.5	3.0	ns
BR_{SDI}	Serial Input Data Rate	SMPTE 259M, Level C	SDI, \overline{SDI}		270		M_{BPS}
		SMPTE 259M, Level D			360		
		SMPTE 344M			540		
		SMPTE 292M			1,483		
		SMPTE 292M			1,485		
$V_{CM(SDI)}$	Common Mode Voltage	$V_{IN} = 125$ mV _{P-P}		$V_{SSSI} + 1.0V$		$V_{DDSI} - 0.05V$	V
$V_{IN(SDI)}$	SDI Serial Input Voltage, Single-ended			125	800	880	mV _{P-P}
$V_{IN(SDI)}$	SDI Serial Input Voltage, Differential		SDI, \overline{SDI}	125	800	880	mV _{P-P}
t_r, t_f	Rise Time, Fall Time	20%–80%, SMPTE 259M Data Rates		0.4	1.0	1.5	ns
		20%–80%, SMPTE 292M Data Rates				270	ps
f_{ACLK}	Ancillary / Control Data Clock Frequency					V_{CLK}	MHz
DC_{ACLK}	Duty Cycle, Ancillary Clock		A_{CLK}	45	50	55	%
t_r, t_f	Ancillary / Control Clock and Data Rise Time, Fall Time	10%–90%		1.0	1.5	3.0	ns

Symbol	Parameter	Conditions	Reference	Min	Typ	Max	Units
t_s	Setup Time, AD_N to A_{CLK} or IO_N to A_{CLK} Rising Edge	Control Data Input or I/O Bus Input	IO_N , AD_N , A_{CLK} Timing Diagram	3.0	1.5		ns
t_H	Hold Time, Rising Edge A_{CLK} to AD_N or A_{CLK} to IO_N			3.0	1.5		ns
R_{REF}	Bias Supply Reference Resistor	Tolerance 1%			4.75k		Ω
$f_{EXT\ CLK}$	External Clock Frequency		Ext Clk	-100 ppm	27.0	+100 ppm	MHz
f_{XTAL}	Crystal Frequency	Figure 6	XTALo, XTALi				

DC Electrical Characteristics

Over Supply Voltage and Operating Temperature ranges, unless otherwise specified (*Note 2*, *Note 3*).

Symbol	Parameter	Conditions	Reference	Min	Typ	Max	Units
V_{IH}	Input Voltage High Level		All LVCMOS Inputs	2.0		V_{DDIO}	V
V_{IL}	Input Voltage Low Level			V_{SSIO}		0.8	
I_{IH}	Input Current High Level	$V_{IH} = V_{DDIO}$ (<i>Note 8</i>)			+85	+150	μA
I_{IL}	Input Current Low Level	$V_{IL} = V_{SSIO}$			-1	-20	
V_{OH}	Output Voltage High Level	$I_{OH} = -2\text{ mA}$	All LVCMOS Outputs	2.4	2.7	V_{DDIO}	V
V_{OL}	Output Voltage Low Level	$I_{OL} = +2\text{ mA}$		V_{SSIO}	$V_{SSIO} + 0.3$	$V_{SSIO} + 0.5V$	
V_{OHV}	Minimum Dynamic V_{OH}	$I_{OH} = -2\text{ mA}$ (<i>Note 6</i>)			$V_{DDIO} - 0.5$		
V_{OLP}	Maximum Dynamic V_{OL}	$I_{OL} = +2\text{ mA}$ (<i>Note 6</i>)			$V_{SSIO} + 0.4$		
V_{SDI}	Serial Data Input Voltage		SDI, \overline{SDI}	125	800	880	mV_{P-P}
I_{SDI}	Serial Data Input Current				± 1	± 10	μA
V_{TH}	Input Threshold	Over VCM range			<100		mV
I_{BB}	Bias Supply Output Current	$R_{BB} = 8.66k\Omega$ 1%		-220	-188		μA
I_{REF}	Reference Output Current	$R_{REF} = 4.75k\Omega$ 1%		-290	-262		
$I_{DD} (3.3V)$	Power Supply Current, 3.3V Supply, Total	270M _{BPS} Data Rate	V_{DDIO} , V_{DDSI}		38.0	45.0	mA
		1,485M _{BPS} Data Rate			47.0	50.0	
$I_{DD} (2.5V)$	Power Supply Current, 2.5V Supply, Total	270M _{BPS} Data Rate	V_{DDD} , V_{DDPLL}		80	120	mA
		1,485M _{BPS} Data Rate			220	340	

AC Electrical Characteristics

Over Supply Voltage and Operating Temperature ranges, unless otherwise specified (*Note 3*).

Symbol	Parameter	Conditions	Reference	Min	Typ	Max	Units	
Serial Video Data Inputs								
BR _{SDI}	Serial Input Data Rate	SMPTE 259M, Level C	SDI, $\overline{\text{SDI}}$		270		M _{BPS}	
		SMPTE 259M, Level D			360			
		SMPTE 344M			540			
		SMPTE 292M			1,483			
		SMPTE 292M			1,485			
t _r , t _f	Rise Time, Fall Time	20%–80%, SMPTE 259M Data Rates		0.4	1.0	1.5	ns	
		20%–80%, SMPTE 292M Data Rates				270	ps	
Parallel Video Data Outputs								
f _{VCLK}	Video Output Clock Frequency	SMPTE 259M, 270M _{BPS}	V _{CLK}		27.0		MHz	
		SMPTE 267M, 360M _{BPS}			36.0			
		SMPTE 344M, 540M _{BPS}			54.0			
		SMPTE 292M, 1,483M _{BPS}			74.176			
		SMPTE 292M, 1,485M _{BPS}			74.25			
t _{pd}	Propagation Delay, Video Clock to Video Data Valid	50%–50%	V _{CLK} to DV _N Timing Diagram		0.5	2.0	ns	
DC _V	Duty Cycle, Video Clock		V _{CLK}		50±5		%	
t _{JIT}	Video Data Output Clock Jitter	27MHz	V _{CLK}		2.0		ns _{p-p}	
		36MHz			1.4			
		54MHz			1.0			
		74.25MHz			0.5			
Parallel Ancillary / Control Data Inputs, Multi-function Parallel Bus Inputs								
f _{ACLK}	Ancillary / Control Data Clock Frequency		A _{CLK}			V _{CLK}	MHz	
DC _A	Duty Cycle, Ancillary Data Clock	ANC Data clock (<i>Note 7</i>)			45	50	55	%
t _r , t _f	Output Rise Time, Fall Time	10%–90%	IO _N , AD _N , A _{CLK} Timing Diagram		1.0	1.5	3.0	ns
t _S	Setup Time, AD _N to A _{CLK} or IO _N to A _{CLK} Rising Edge	Control Data Input or I/O Bus Input			3.0	1.5		
t _H	Hold Time, Rising Edge A _{CLK} to AD _N or A _{CLK} to IO _N				3.0	1.5		
Parallel Ancillary / Control Data Outputs								
t _{pd}	Propagation Delay, Clock to Control Data	50%–50%	A _{CLK} to AD _N Timing Diagram		8.5		ns	
t _{pd}	Propagation Delay, Clock to Ancillary Data				11.5			
Multi-function Parallel I/O Bus								
t _r , t _f	Rise Time, Fall Time	10%–90%	IO0–IO7 Timing Diagram	1.0	1.5	3.0	ns	
PLL/CDR, Format Detect								
t _{LOCK}	Lock Detect Time	SD Rates (<i>Note 5</i>)			0.32	1.0	ms	
		HD Rates (<i>Note 5</i>)			0.26	1.0		
t _{FORMAT}	Format Detect Time	All Rates			20			

Note 1: “Absolute Maximum Ratings” are those parameter values beyond which the life and operation of the device cannot be guaranteed. The stating herein of these maximums shall not be construed to imply that the device can or should be operated at or beyond these values. The table of “Electrical Characteristics” specifies acceptable device operating conditions.

Note 2: Current flow into device pins is defined as positive. Current flow out of device pins is defined as negative. All voltages are referenced to $V_{SSIO} = V_{SSD} = V_{SSSI} = 0V$.

Note 3: Typical values are stated for $V_{DDIO} = V_{DDSI} = +3.3V$, $V_{DDD} = V_{DDPLL} = +2.5V$ and $T_A = +25^\circ C$.

Note 4: Spec. is guaranteed by design.

Note 5: Measured from rising-edge of first SDI cycle until Lock Detect bit goes high (true). Lock time includes CDR phase acquisition time plus PLL lock time.

Note 6: V_{OHV} and V_{OLP} are measured with respect to reference ground. V_{OLP} is the peak output LOW voltage or ground bounce that may occur under dynamic simultaneous output switching conditions. V_{OHV} is the lowest output HIGH voltage or output droop that may occur under dynamic simultaneous output switching conditions.

Note 7: When used to clock control data into or from the CLC031A, the duty cycle restriction does not apply.

Note 8: I_{IH} includes static current required by input pull-down devices.

Note 9: Required Input Conditions are the electrical signal conditions or component values which shall be supplied by the circuit in which this device is used in order for it to produce the specified DC and AC electrical output characteristics.

Note 10: Functional and certain other parametric tests utilize a CLC030 as the input source to the SDI inputs of the CLC031A. The CLC030 is DC coupled to the inputs of the CLC031A. Typical $V_{IN} = 800\text{ mV}$, $V_{CM} = 2.9\text{ V}$.

Test Loads

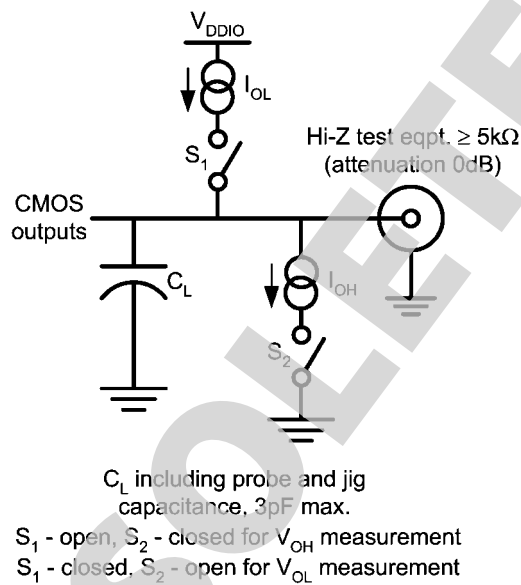

20020104

Test Circuit

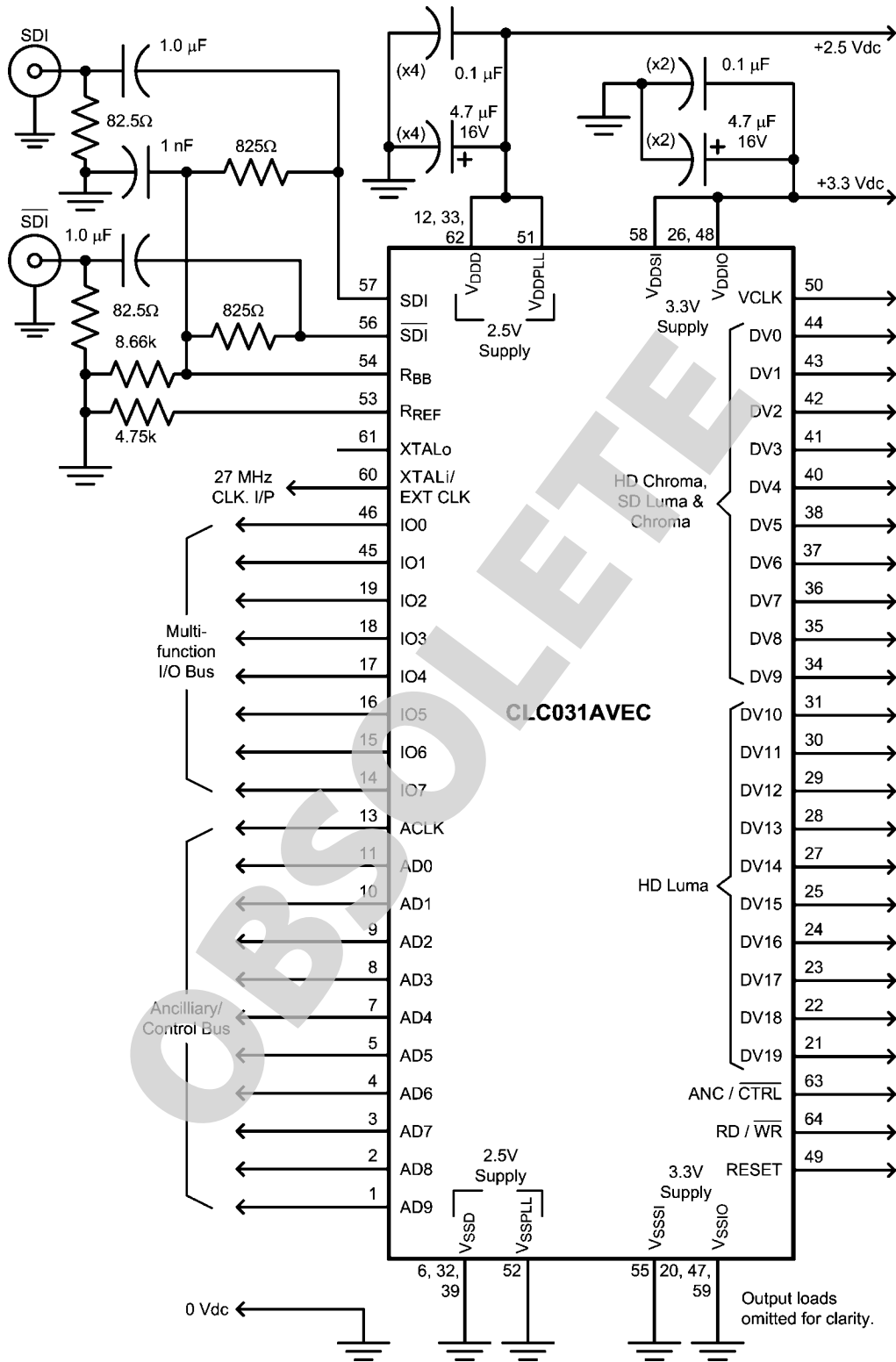

20020107

Timing Diagram

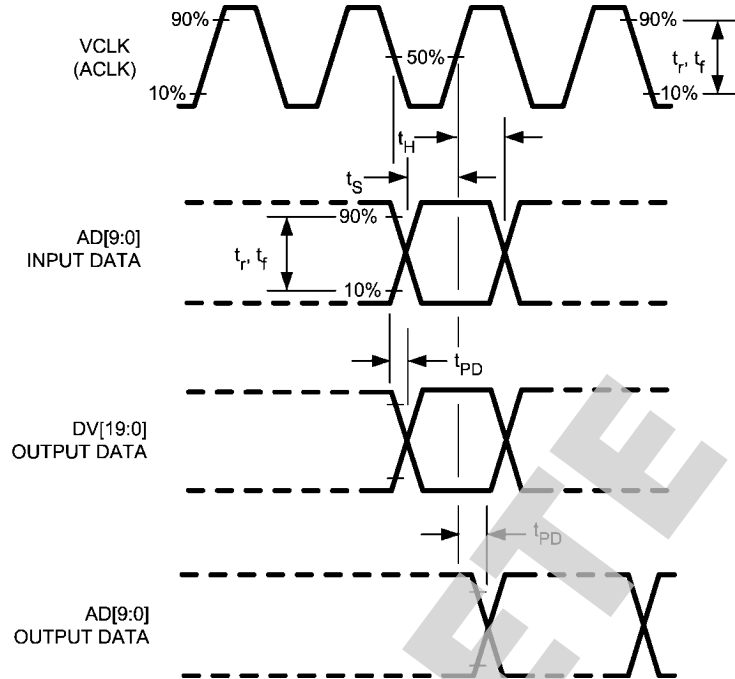

20020108

Device Operation

INTRODUCTION

The CLC031A SMPTE 292M/259M Digital Video Deserializer/Decoder is used in digital video signal origination and destination equipment: cameras, video tape recorders, telecines, editors, standards converters, video test and other equipment. It decodes and converts serial SDTV or HDTV component digital video signals into parallel format. The CLC031A decoder/deserializer processes serial digital video (SDV) signals conforming to SMPTE 259M, SMPTE 344M (proposed) or SMPTE 292M and operates at serial data rates of 270 Mbps, 360 Mbps, 540 Mbps, 1.483 Gbps and 1.485 Gbps. Corresponding parallel output data rates are 27.0 MHz, 36.0 MHz, 54.0 MHz, 74.176MHz and 74.25 MHz.

The CLC031A accepts ECL or LVDS serial data input signals. Outputs signals are compatible with LVCMOS logic devices.

Note: In the following explanations, these logical equivalences are observed: ON Enabled Set True Logic_1 and OFF Disabled Reset False Logic_0.

VIDEO DATA PATH

The **Serial Data Inputs (SDI)** accept serial video data at SMPTE 259M standard definition, SMPTE 344M (proposed) or SMPTE 292M high-definition data rates. These inputs accept standard ECL or LVDS signal levels and may be used single-ended or differentially. Inputs may be DC or AC coupled, as required, to devices and circuits supplying the data. Recommended operating conditions and all input DC and AC voltage and current specifications shall be observed when designing the input coupling circuits.

For convenience, a reference bias source, pin name R_{REF} , sets the reference current available from the input bias source, pin name R_{BB} . The recommended nominal value of R_{REF} is 4.75k Ω , 1%. R_{BB} is provided so that the SDI inputs may be supplied DC bias voltage via external resistors when the inputs are AC-coupled. The bias source should be loaded with a resistance to the V_{SS} supply. The source current available at R_{BB} is 200 μ A. [Figure 1](#) shows a typical input biasing scheme using R_{BB} and R_{REF} .

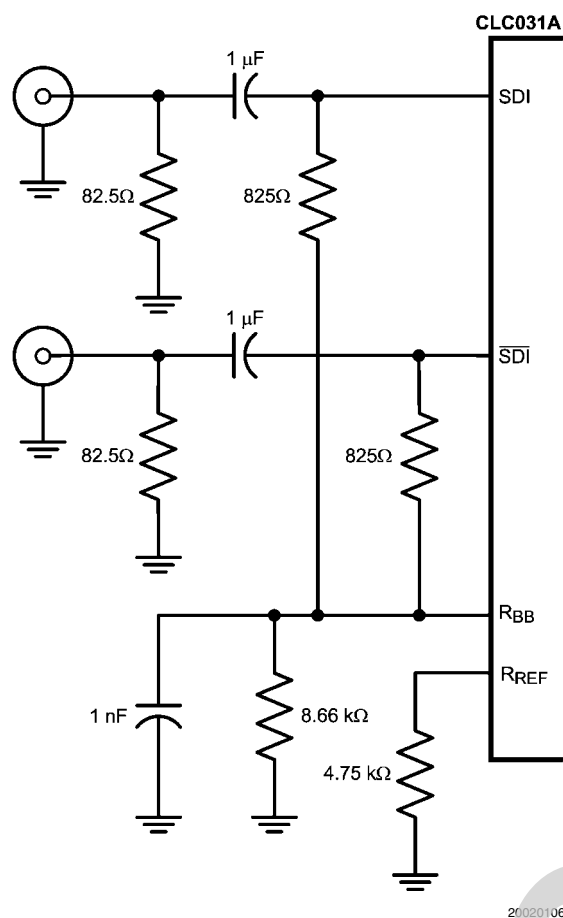

FIGURE 1. Optional Input Biasing Scheme

The **SMPTE descrambler** receives NRZI serial data, converts it to NRZ, then decodes it to either 10-bit standard definition or 20-bit high definition parallel video data using the reverse polynomial $X^9 + X^4 + 1$ as specified in the respective standard: SMPTE 259M, SMPTE 344M (proposed) or SMPTE 292M. The data reception bit order is LSB-first. All data processing is done at the parallel rate.

The CLC031A incorporates circuitry that implements a method for handling data that has been subjected to **LSB dithering**. When so enabled, data from the de-scrambler is routed for de-dithering. The **De-Dither Enable** bit in the **VIDEO INFO 0** control register enables this function. De-dithering of data present in the vertical blanking interval can be selectively enabled by use of the **V De-Dither Enable** bit in the **VIDEO INFO 0** control register. The initial condition of **De-Dither Enable** and **V De-Dither Enable** is OFF.

The descrambler supplies signals to the **TRS character detector** which identifies the presence of the valid video data. The **TRS character detector** processes the timing reference signals which control raster framing. TRS (sync) characters are detected and the video is aligned on word boundaries.

Data is re-synchronized with the parallel word-rate clock. Interaction and operation of the character alignment control signals and indicators **Framing Mode**, **Framing Enable** and **NSP** (New Sync Position) is described later in this datasheet. The CLC031A implements TRS character LSB-clipping as prescribed in ITU-R BT.601. LSB-clipping causes all TRS characters with a value between 000h and 003h to be forced to 000h and all TRS characters with a value between 3FFh and 3FFh to be forced to 3FFh. Clipping is done after descrambling and de-dithering.

Once the PLL attains lock, the **video format detector** processes the received data to determine the raster characteristics (video data format) and configure the CLC031A to handle it. This assures that the parallel output data will be properly formatted, that the correct data rate is selected and that Ancillary Data and CRC/EDH data are correctly detected and checked. Supported parallel data formats or sub-formats may belong to any one of several component standards: SMPTE 125M, SMPTE 267M, SMPTE 260M, 274M, 295M or 296M. Refer to [Table 4](#) for the supported formats. (See also the [Application Information](#) section for handling of other raster formats or format extensions developed after this device was designed). The detected video standard information is passed to the device control system and saved in the control registers from whence it may be read by the user.

The CLC031A may be configured to operate in a single video format by loading the appropriate **FORMAT SET[4:0]** control data into the **FORMAT 0** control register. Also, the CLC031A may be configured to handle only the standard-definition data formats by setting the **SD ONLY** bit or only the high-definition data formats by setting the **HD ONLY** bit in the **FORMAT 0** control register. When both bits are reset, the default condition, the part automatically detects the data rate and range.

Aligned and de-processed parallel data passes into a variable-depth **video FIFO** prior to output. Video FIFO depth from 0 to 4 registers is set by a 3-bit word written into the **VIDEO FIFO Depth[2:0]** bits in the **ANC 0** control register. The video FIFO permits adjustment of the parallel video data output timing or delay at a parallel word rate. The occurrence of corresponding TRS indicator bits, EAV, SAV and NSP, in the control register corresponds to the input register position of the FIFO. This positioning permits a look-ahead function in which the alignment status of the video data can be determined up to four parallel clock periods prior to the appearance of that data at the parallel data output.

The parallel video data is output on **DV[19:0]**. The 20-bit parallel video data is organized so that for HDTV data, the upper-order 10 bits **DV[19:10]** are luminance (luma) information and the lower 10 bits **DV[9:0]** are colour difference (chroma) information. SDTV data use the lower-order 10-bits **DV[9:0]** for both luma and chroma information. (The SDTV parallel data is also duplicated on **DV[19:10]**). **V_{CLK}** is the parallel output word rate clock signal. The frequency of **V_{CLK}** is appropriate to either the HD or SD data being processed. Data is valid between the falling edges of a **V_{CLK}** cycle. Data may be clocked into external devices on the rising-edge of **V_{CLK}**. The **DV[19:0]** and **V_{CLK}** signals are LVCMOS-compatible.

ANCILLARY/CONTROL DATA PATH

The 10-bit **ancillary and Control Data Port AD[9:0]** serves two functions in the CLC031A. Ancillary Data from the **Ancillary Data FIFO** is output from this port after its recovery from the video data stream. The utilization and flow of Ancillary Data from the device is managed by a system of control bits, masks and IDs stored in the control data registers. This port also provides read/write access to contents of the configuration and control registers. The signals **RD/WR**, **ANC/CTRL** and **A_{CLK}** control data flow through the port.

CONTROL DATA FUNCTIONS

Control data is input to and output from the CLC031A using the lower-order 8 bits **AD[7:0]** of the ancillary/Control Data Port. This control data initializes, monitors and controls operation of the CLC031A. The upper two bits **AD[9:8]** of the port function as handshaking signals with the device accessing the port. When either a control register read or write address is being written to the port, **AD[9:8]** must be driven as 00b (0XXh, where XX are AD[7:0]). When control data is being written to the port, **AD[9:8]** must be driven as 11b (3XXh, where XX are AD[7:0]). When control data is being read from the port, the CLC031A will output **AD[9:8]** as 10b (2XXh, where XX are output data AD[7:0]) and may be ignored by the monitoring system.

Note: After either a manual or power-on reset, **A_{CLK}** must be toggled three (3) times to complete initialization of the **Ancillary and Control Data Port**.

The sequence of clock and control signals for reading control data from the ancillary/control data port is shown in [Figure 2](#). **Control data read mode** is invoked by making the **ANC/CTRL** input low and the **RD/WR** input high. The 8-bit address of the control register set to be accessed is input to the port on bits **AD[7:0]**. To identify the data as an address, **AD[9:8]** must be driven as 00b. The complete address word will be 0XXh, where 0 is AD[9:8] and XX are AD[7:0]. The address is captured on the rising edge of **A_{CLK}**. When control data is being read from the port, the CLC031A will output **AD[9:8]** as 10b (2XXh, where XX are output data AD[7:0]) and may be ignored by the monitoring system. Data being output from the selected register is driven by the port immediately following the rising edge of **A_{CLK}** or when the address signal is removed. For optimum system timing, the signals driving the address to the port should be removed immediately after the address is clocked into the port and before or simultaneously

with the falling edge of **A_{CLK}** at the end of that address cycle. Output data remains stable until the next rising edge of **A_{CLK}** and may be written into external devices at any time after the removal of the address signal. This second clock resets the port from drive to receive and readies the port for another access cycle.

Example: Read the Full-field Flags via the AD port.

1. Set **ANC/CTRL** to a logic-low.
2. Set **RD/WR** to a logic-high.
3. Present 001h to **AD[9:0]** as the register address.
4. Toggle **A_{CLK}**.
5. Release the bus driving the AD port.
6. Read the data present on the AD port. The Full-field Flags are bits AD[4:0].
7. Toggle **A_{CLK}** to release the AD port.

[Figure 3](#) shows the sequence of clock and control signals for writing control data to the ancillary/control data port. The **control data write mode** is similar to the read mode. Control data write mode is invoked by making the **ANC/CTRL** input low and the **RD/WR** input low. The 8-bit address of the control register set to be accessed is input to the port on bits **AD[7:0]**. When a control register write address is being written to the port, **AD[9:8]** must be driven as 00b (0XXh, where XX are AD[7:0]). The address is captured on the rising edge of **A_{CLK}**. The address data is removed on the falling edge of **A_{CLK}**. Next, the control data is presented to the port bits **AD[7:0]** and written into the selected register on the next rising edge of **A_{CLK}**. When control data is being written to the port, **AD[9:8]** must be driven as 11b (3XXh, where XX are AD[7:0]). Control data written into the registers may be read out non-destructively in most cases.

Example: Setup (without enabling) the TPG Mode via the AD port using the 1125 line, 30 frame, 74.25MHz, interlaced component (SMPTE 274M) colour bars as test pattern. The TPG may be enabled after setup using the Multi-function I/O port or by the control registers.

1. Set **ANC/CTRL** to a logic-low.
2. Set **RD/WR** to a logic-low.
3. Present 00Dh to **AD[9:0]** as the Test 0 register address.
4. Toggle **A_{CLK}**.
5. Present 327h to **AD[9:0]** as the register data.
6. Toggle **A_{CLK}**.

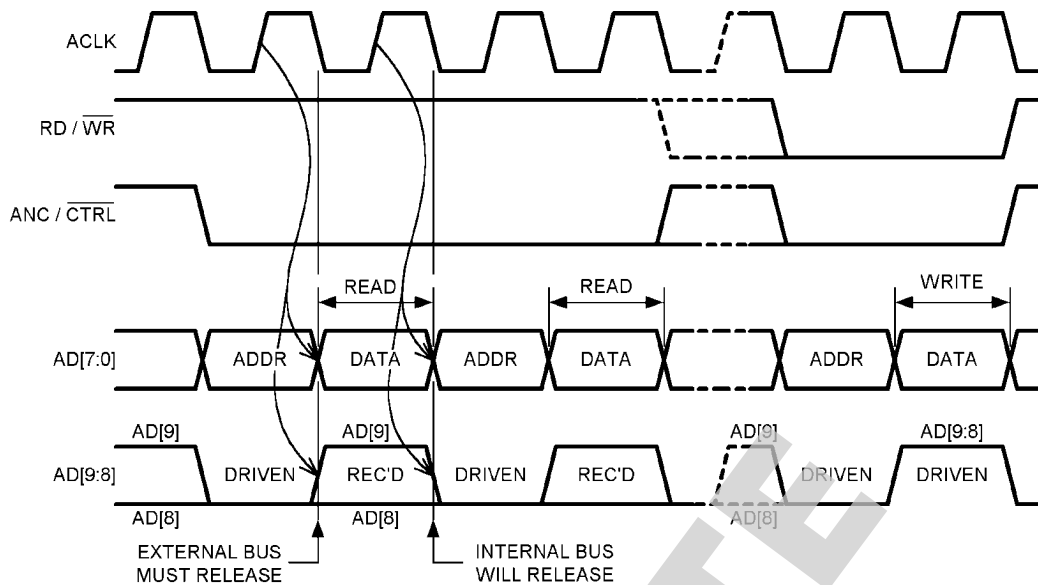

20020109

FIGURE 2. Control Data Read Timing (2 read and 1 write cycle shown)

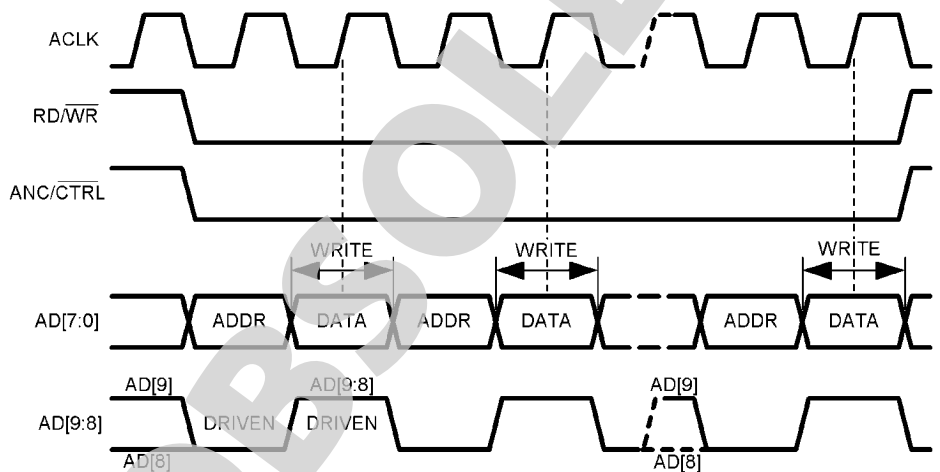

20020110

FIGURE 3. Control Data Write Timing

Ancillary Data Functions

The CLC031A can recover **Ancillary Data** from the serial data stream. This Ancillary Data and related control characters are defined in the relevant SMPTE standards and may reside in the horizontal and vertical blanking intervals. The data can consist of different types of message packets including audio data. The serial Ancillary Data space must be formatted according to SMPTE 291M. **The CLC031A supports Ancillary Data in the chrominance channel (C'r/C'b) only for high-definition operation.** Ancillary Data for standard definition follows the requirements of SMPTE 125M.

The **Ancillary Data FIFO** is sized to handle a maximum length ANC data Type 1 or Type 2 packet without the ANC Flag, 259 words. Defined in SMPTE 291M, the packet consists of the Ancillary Data Flag, a 3-word Data ID and Data Count, 255 8- or 10-bit User Data Words and a Checksum.

The design of the CLC031A **Ancillary Data FIFO** also allows storage of up to 8 shorter length messages with total length not exceeding 259 words including all ID information. **Ancillary Data** is copied from the data stream into the **Ancillary Data FIFO**. The parallel Ancillary Data will still be present in the parallel chroma output **DV[9:0]**. ancillary flag information is not extracted into the FIFO.

Copying of ANC data from the video data into the FIFO is controlled by the **ANC Mask** and **ANC ID** bits in the control registers. A system of flags, **ANC FIFO Empty**, **ANC FIFO 90% Full**, **ANC FIFO Full** and **ANC FIFO Overrun** are used to monitor FIFO status. The details and functions of these and other control words are explained later in this datasheet.

Figure 4 shows the relationship of clock, data and control signals for reading **Ancillary Data** from the port **AD[9:0]**. In Ancillary Data read mode, 10-bit Ancillary Data is routed from

the **Ancillary Data FIFO** and read from the port **AD[9:0]** at a rate determined by **A_{CLK}**.

Ancillary Data read (output) mode is invoked by making the **ANC/CTRL** input high and the **RD/WR** input high. **Ancillary Data** is clocked from the FIFO on the L-H transition of **A_{CLK}**. Data may be read from the port on rising edges of **A_{CLK}**, after the specified propagation delay, until the FIFO is emptied. Data may only be read from the port when in the Ancillary Data mode. Ancillary Data cannot be written to the port.

To conserve power when the Ancillary Data function is not being used, the internal **Ancillary Data FIFO** clock is disabled. This clock must be enabled before Ancillary Data may be replicated into the FIFO for output. This internal FIFO clock is controlled by **FIFO CLOCK ENABLE**, bit-6 of the **ANC 5** register (address 17h). The default condition of **FIFO CLOCK ENABLE** is OFF. After enabling the internal FIFO clock by turning this bit ON, **A_{CLK}** must be toggled three (3) times to propagate the enable to the clock tree.

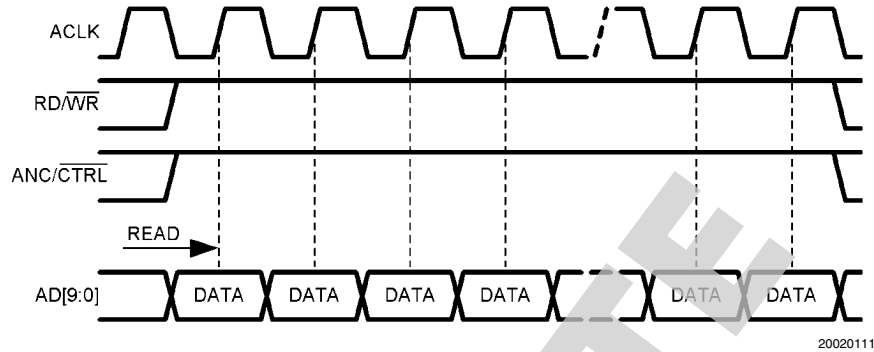

FIGURE 4. Ancillary Data Read Timing

MULTI-FUNCTION I/O PORT

The **multi-function I/O port** can be configured to provide immediate access to many control and indicator functions that are stored within the CLC031A's configuration and control registers. The individual pins comprising this port are assigned as input or output for selected functions stored in the control data registers.

The multi-function I/O port is configured by way of an 8x6-bit register bank consisting of registers **I/O pin 0 CONFIG** through **I/O pin 7 CONFIG**. The contents of these registers determine whether the port bits function as inputs or outputs and to which control function or indicator each port bit is assigned. Port bits may be assigned to access different functions and indicators or any or all port bits may be assigned to access the same function or indicator (output mode only). The same indicator or function should not be assigned to more than one port bit as an input. Controls and indicators that are accessible by the port and their corresponding selection addresses are given in the I/O Pin Configuration Register Addresses, [Table 6](#). [Table 2](#) gives the control register bit assignments.

Data resulting from device operation will be sent to the selected I/O port bit. This same data is also stored in the configuration and control registers. Mapping the control and indicator functions in this manner means that device operation will be immediately reflected at the I/O port pins thereby ensuring more reliable real-time operation of the device within and by the host system.

When a multifunction I/O port bit is used as input to a control register bit, data must be presented to the I/O port bit and clocked into the register bit using **A_{CLK}** as shown in [Figure 5](#). Port timing for bit write operations is the same as for the **ANC/CTRL** port operation.

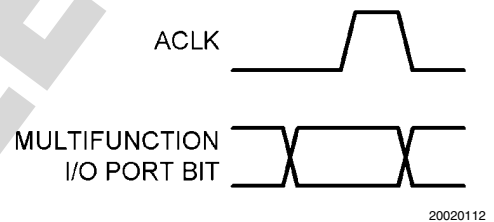

FIGURE 5. I/O Port Data Write Timing

Example: Program multi-function I/O port bit-0 as the CRC Luma Error bit output.

1. Set **ANC/CTRL** to a logic-low.
2. Set **RD/WR** to a logic-low.
3. Present 00Fh to **AD[9:0]** as the **I/O PIN 0 CONFIG** register address.
4. Toggle **A_{CLK}**.
5. Present 310h to **AD[9:0]** as the register data.
6. Toggle **A_{CLK}**.

EDH/CRC SYSTEM

The CLC031A has **EDH** and **CRC character generation and checking** circuitry. The EDH system functions as described in SMPTE Recommended Practice RP-165. The CRC system functions as specified in SMPTE 292M. The **EDH/CRC polynomial generators/checkers** accept parallel data from the de-serializing system and generate the EDH and CRC check words for comparison with those received in the data.

The **EDH Enable** bit in the control register enables the EDH generation and checking system. Incoming SDTV data is checked for errors and the EDH flags are updated automatically. EDH errors are reported in the EDH0, EDH1, and EDH2 register sets of the configuration and control registers.

Updated or new EDH check words and flags may be generated and inserted in the data. EDH check words are generated using the polynomial $X^{16} + X^{12} + X^6 + 1$ per SMPTE RP165. Generation and automatic insertion of new or cor-

rected EDH check words is controlled by **EDH Force** and **EDH Enable** bits in the control registers. EDH check words and status flags are inserted in the parallel data at the correct positions in the Ancillary Data space and formatted per SMPTE 291M. After a reset, the initial state of all EDH and CRC check characters is 00h.

The SMPTE 292M high definition video standard employs **CRC** (cyclic redundancy check codes) error checking instead of EDH. The CRC consists of two 18-bit words generated using the polynomial $X^{18} + X^5 + X^4 + 1$ per SMPTE 292M. One CRC is used for luminance and one for chrominance data. The CRCs appear in the data stream following the EAV and line number characters. The CRCs are checked and errors are reported in the EDH0, EDH1, and EDH2 register sets of the configuration and control registers.

PHASE-LOCKED LOOP / CLOCK-DATA RECOVERY SYSTEM

The **phase-locked loop and clock-data recovery** (PLL/CDR) system generates all internal timing and data rate clocks for the CLC031A. The PLL/CDR system consists of five main functional blocks: 1) the input buffer which receives the incoming data, 2) input data samplers which oversample the data coming from the input buffer, 3) a PLL (VCO, divider chain, phase-frequency detector and internal loop filter) which generates sampling and other system clocks, 4) a digital CDR system to recover the oversampled serial input data from the samplers and the digital system control and 5) a rate detect controller which sequences the PLL to find the data rate.

Using an oversampling technique, the timing information encoded in the serial data is extracted and used to synchronize the recovered clock and data. The parallel data rate and other clock signals are derived from the regenerated serial clock. The parallel data rate clock is 1/10th of the serial data rate clock for standard definition or 1/20th of the serial data clock frequency for high definition. The data interface between the CDR and the digital processing block uses 10-bit data plus the required clocks.

The PLL is held in coarse frequency lock by an external 27MHz clock signal, **EXT CLK**, or by an external **27MHz crystal** and internal oscillator. Upon power-on, **EXT CLK** is the default reference. The internal oscillator and an external crystal may be used as the reference by setting the **OSCEN** bit in the **CDR register**. The reference clock reduces lock latency and enhances format and auto-rate detection robustness. PLL acquisition, data phase alignment and format detection time is 20ms or less at 1.485Mbps. The VCO has separate V_{DDPLL} and V_{SSPLL} power supply feeds, pins 51 and 52, which may be supplied power via an external low-pass filter, if desired.

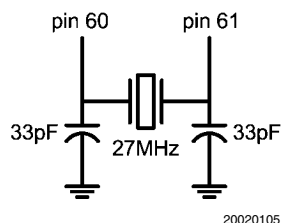

FIGURE 6. Crystal and Load Circuit

A 27MHz crystal and load circuit may be used to provide the reference clock. A fundamental mode crystal with the following parameters is used: frequency 27MHz, frequency tolerance ± 30 ppm, load capacitance 18pF, maximum drive level 100 μ W, equivalent series resistance $< 50\Omega$, operating temperature range 0°C to 70°C. Refer to *Figure 6* for a typical load circuit and connection information.

The CLC031A indicates that the PLL is locked to the incoming data rate and that the CDR has acquired a phase of the serial data by setting the **Lock Detect** bit in the **Video Info 0** control register. Indication of the standard being processed is retained in the **FORMAT[4:0]** bits in the **FORMAT 1** control data register. Format data from this register can be programmed for output on the multi-function I/O port. The power-on default assigns **Lock Detect** as I/O Port bit 4.

POWER SUPPLIES, POWER-ON-RESET AND RESET INPUT

The CLC031A requires two power supplies, 2.5V for the core logic functions and 3.3V for the I/O functions. The supplies must be applied to the device in proper sequence. The 3.3V supply must be applied prior to or coincident with the 2.5V supply. Application of the 2.5V supply must not precede the 3.3V supply. It is recommended that the 3.3V supply be configured or designed so as to control application of the 2.5V supply in order to satisfy this sequencing requirement.

The CLC031A has an automatic, **power-on-reset** circuit. Reset initializes the device and clears TRS detection circuitry, all latches, registers, counters and polynomial generators/checkers and resets the EDH/CRC characters to 00h. An active-HIGH-true, manual **reset input** is available at pin 49. The reset input has an internal pull-down device and may be considered inactive when unconnected.

Important: When power is first applied to the device or following a reset, the **ancillary and Control Data Port** must be initialized to receive data. This is done by toggling **A_{CLK}** three times.

TEST PATTERN GENERATOR (TPG) AND BUILT-IN SELF-TEST (BIST)

The CLC031A includes an on-board, parallel video **test pattern generator (TPG)**. Four test pattern types are available in both HD and SD formats, NTSC and PAL standards, and 4x3 and 16x9 raster sizes. The test patterns are: flat-field black, PLL pathological, equalizer (EQ) pathological and a 75%, 8-colour vertical bar pattern. The pathologicals follow recommendations contained in SMPTE RP 178-1996 regarding the test data used. The colour bar pattern has optional bandwidth limiting coding in the chroma and luma data transitions between bars. The **VPG FILTER ENABLE** bit in the **VIDEO INFO 0** control register enables the colour bar filter function. The test pattern data is available at the video data outputs, **DV[19:0]** with a corresponding parallel rate clock, **VCLK**, appropriate to the particular standard and format selected.

The **TPG** also functions as a **built-in self-test (BIST)** which can be used to verify device functionality. The **BIST** function performs a comprehensive go/no-go test of the device. The test may be run using any of the HD colour bar patterns or one of two SD patterns, either the 270 Mb/s NTSC colour bar or the PAL PLL pathological, as the test data pattern. Data is input from the digital processing block, processed through the device and tested for errors using either the EDH system for SD or the CRC system for HD. Clock signals from the CDR block supply timing for the test data. The CDR must be supplied a 27MHz reference clock via the **XTALi/Ext Clk** input (or using the internal oscillator and crystal) during the **TPG** or **BIST** function. A go/no-go indication is logged in the **Pass/Fail** bit of the **TEST 0** control register set. This bit may be assigned as an output on the multifunction I/O port.

TPG and **BIST** operation is initiated by loading the code for the desired test pattern into the **Test Pattern Select[5:0]** bits and by setting the **TPG Enable** bit of the **TEST 0** register. Note that when attempting to use the TPG or BIST immediately after the device has been reset or powered on, the TPG defaults to the 270Mbps SD rate. The device must be configured for the desired test pattern by loading the appropriate code in to the **TEST 0** register. If HD operation is desired,

selection of the desired HD test pattern is sufficient to enable the device to configure itself to run at the correct rate and generate valid data. [Table 5](#) gives the available test patterns and codes.

The **Pass/Fail** bit in the control register gives the device test status indication. If no errors have been detected, this bit will be set to logic-1 approximately 2 field intervals after **TPG Enable** is set. If errors have been detected in the internal circuitry of the CLC031A, **Pass/Fail** will remain reset to a logic-0. TPG or BIST operation is stopped by resetting the **TPG Enable** bit. Parallel output data is present at the **DV[19:0]** outputs during TPG or BIST operation.

Example: Enable the TPG Mode to use the NTSC 270Mbps colour bars as the BIST and TPG pattern. Enable TPG operation using the I/O port.

1. Set **ANC/CTRL** to a logic-low.
2. Set **RD/WR** to a logic-low.
3. Present 00Dh to **AD[9:0]** as the **TEST 0** register address.
4. Toggle **A_{CLK}**.
5. Present 343h to **AD[9:0]** as the register data (525 line, 30 frame, 27MHz, NTSC 4x3, colour bars (SMPTE 125M)).
6. Toggle **A_{CLK}**.
7. The **PASS/FAIL** indicator, **TEST 0** register, Bit 7, should be read for the result of the test. Alternatively, this bit may be mapped to a convenient bit of the Multi-function I/O bus. The test pattern data and clock is available at the **DV[19:0]** and **V_{CLK}** outputs.

CONFIGURATION AND CONTROL REGISTERS

The configuration and control registers store data which determines the operational modes of the CLC031A or which result from its operation. Many of these registers may be assigned as external I/O functions which are then available on the multi-function I/O bus. These functions are summarized in [Table 1](#) and detailed in [Table 2](#). The power-on default condition for the multi-function I/O port is indicated in [Table 1](#) and detailed in [Table 6](#).

TABLE 1. Configuration and Control Data Register Summary

Register Function	Bits	Read or Write	Initial Condition	Available on I/O Bus	Notes
EDH and CRC Operations					
CRC Error (SD/HD)	1	R	Reset	Output	(Note 11) I/O 5
CRC Error Luma	1	R	Reset	Output	
CRC Error Chroma	1	R	Reset	Output	
CRC Replace	1	R/W	OFF	No	(Note 13)
Full-Field Flags	5	R	Reset	No	
Active Picture Flags	5	R	Reset	No	
ANC Flags	5	R	Reset	No	
EDH Force	1	R/W	OFF	Input	
EDH Enable	1	R/W	ON	Input	
F/F Flag Error	1	R	Reset	Output	
A/P Flag Error	1	R	Reset	Output	
ANC Flag Error	1	R	Reset	Output	
Ancillary Data Operations					
ANC Checksum Force	1	R/W	OFF	Input	
ANC Checksum Error	1	R	Reset	Output	
ANC FIFO Empty	1	R	Set	Output	(Note 11) I/O 6
ANC FIFO 90% Full	1	R	Reset	Output	
ANC FIFO Full	1	R	Reset	Output	
ANC FIFO Overrun	1	R	Reset	Output	
ANC ID	16	R/W	0000h	No	
ANC Mask	16	R/W	FFFFh	No	
MSG Track	1	R/W	OFF	No	
MSG Flush Static	1	R/W	OFF	No	
FIFO Flush Static	1	R/W	OFF	No	
Full MSG Available	1	R	OFF	Output	
Short MSG Detect	1	R	OFF	Output	
FIFO Clock Enable	1	R/W	OFF	No	
FIFO Extract Enable	1	R/W	OFF	Input	
Video FIFO Operation					
Video FIFO Depth	3	R/W	000b	No	
Video Format Operations					
Format Set	5	R/W	00000B	No	
SD Only	1	R/W	OFF	No	
HD Only	1	R/W	OFF	No	
Format	5	R		Output	Format [4] (Note 11) I/O 3
H	1	R		Output	(Note 11) I/O 2
V	1	R		Output	(Note 11) I/O 1
F	1	R		Output	(Note 11) I/O 0
Framing Mode	1	R/W	ON	No	
Framing Enable	1	R/W	ON	Input	
New Sync Position (NSP)	1	R		Output	
SAV	1	R		Output	
EAV	1	R		Output	(Note 11) I/O 7
De-scramble Enable	1	R/W	ON	No	
NRZI Enable	1	R/W	ON	No	

Register Function	Bits	Read or Write	Initial Condition	Available on I/O Bus	Notes		
LSB Clipping Enable	1	R/W	ON	No			
Sync Detect Enable	1	R/W	ON	No			
De-Dither Enable	1	R/W	OFF	Input			
Vert. De-Dither Enable	1	R/W	OFF	Input			
Lock Detect	1	R		Output	(Note 11) I/O 4		
Unscrambled Video Data Out	1	R/W	OFF	No	(Note 13)		
TPG and BIST Operations							
Test Pattern Select	6	R/W	000000b	Input	525/27 MHz/Black		
TPG Enable	1	R/W	OFF	Input			
Pass/Fail	1	R		Output			
VPF Filter Enable	1	R/W	OFF	Input			
Reference Clock Operations							
Reference Clock	2	R/W	00b	No	EXT CLK Enabled		
External Vclk	1	R/W	OFF	No	(Note 13)		
Multifunction I/O Bus Operations							
I/O Bus Pin Config.	48	R/W	See Table 6	No			
<p>Note 11: Connected to multifunction I/O port at power-on.</p> <p>Note 12: ON = SET = logic-1, OFF = RESET = logic-0 (positive logic).</p> <p>Note 13: Special or restricted functionality. Refer to text for details.</p>							
TABLE 2. Control Register Bit Assignments							
Bit 7	Bit 6	Bit 5	Bit 4	Bit 3	Bit 2	Bit 1	Bit 0
EDH 0 (register address 01h)							
CRC ERROR	EDH FORCE	EDH ENABLE	F/F UES	F/F IDA	F/F IDH	F/F EDA	F/F EDH
EDH 1 (register address 02h)							
CRC REPLACE	CRC ERROR LUMA	CRC ERROR CHROMA	A/P UES	A/P IDA	A/P IDH	A/P EDA	A/P EDH
EDH 2 (register address 03h)							
F/F FLAG ERROR	A/P FLAG ERROR	ANC FLAG ERROR	ANC UES	ANC IDA	ANC IDH	ANC EDA	ANC EDH
ANC 0 (register address 04h)							
VIDEO FIFO-DEPTH (2)	VIDEO FIFO-DEPTH(1)	VIDEO FIFO-DEPTH(0)	ANC FIFO OVERRUN	ANC FIFO EMPTY	ANC FIFO FULL	ANC CHECK-SUM ERROR	ANC CHECK-SUM FORCE
ANC 1 (register address 05h)							
ANC ID(7)	ANC ID(6)	ANC ID(5)	ANC ID(4)	ANC ID(3)	ANC ID(2)	ANC ID(1)	ANC ID(0)
ANC 2 (register address 06h)							
ANC ID(15)	ANC ID(14)	ANC ID(13)	ANC ID(12)	ANC ID(11)	ANC ID(10)	ANC ID(9)	ANC ID(8)
ANC 3 (register address 07h)							
ANC MASK(7)	ANC MASK(6)	ANC MASK(5)	ANC MASK(4)	ANC MASK(3)	ANC MASK(2)	ANC MASK(1)	ANC MASK(0)
ANC 4 (register address 08h)							
ANC MASK(15)	ANC MASK(14)	ANC MASK(13)	ANC MASK (12)	ANC MASK (11)	ANC MASK (10)	ANC MASK(9)	ANC MASK(8)
ANC 5 (register address 17h)							
FIFO EXTRACT ENABLE	FIFO CLOCK ENABLE	FULL MSG AVAILABLE	reserved	FIFO FLUSH STATIC	reserved	MSG FLUSH STATIC	MSG TRACK
ANC 6 (register address 18h)							
ANC FIFO 90% FULL	SHORT MSG DETECT	ANC PARITY MASK	reserved	reserved	reserved	reserved	VANC

Bit 7	Bit 6	Bit 5	Bit 4	Bit 3	Bit 2	Bit 1	Bit 0
FORMAT 0 (register address 0Bh)							
FRAMING MODE	SD ONLY	HD ONLY	FORMAT SET (4)	FORMAT SET (3)	FORMAT SET (2)	FORMAT SET (1)	FORMAT SET (0)
FORMAT 1 (register address 0Ch)							
F	V	H	FORMAT(4)	FORMAT(3)	FORMAT(2)	FORMAT(1)	FORMAT(0)
TEST 0 (register address 0Dh)							
PASS/FAIL	TPG ENABLE	TEST PATTERN SELECT(5)	TEST PATTERN SELECT(4)	TEST PATTERN SELECT(3)	TEST PATTERN SELECT(2)	TEST PATTERN SELECT(1)	TEST PATTERN SELECT(0)
VIDEO INFO 0 (register address 0Eh)							
DE-DITHER ENABLE	VERT. DE-DITHER ENABLE	VPG FILTER ENABLE	LOCK DETECT	EAV	SAV	NSP	FRAMING ENABLE
VIDEO CONTROL 0 (register address 55h)							
reserved	EXTERNAL V_{CLK}	SYNC DETECT ENABLE	LSB CLIP ENABLE	reserved	NRZI ENABLE	DE-Scramble ENABLE	reserved
REFERENCE CLOCK (register address 67h)							
reserved	reserved	reserved	reserved	reserved	INT_OSC EN	CLK EN	reserved
MULTI-FUNCTION I/O BUS PIN CONFIGURATION							
I/O PIN 0 CONFIG (register address 0Fh)							
reserved	reserved	PIN 0 SEL[5]	PIN 0 SEL[4]	PIN 0 SEL[3]	PIN 0 SEL[2]	PIN 0 SEL[1]	PIN 0 SEL[0]
I/O PIN 1 CONFIG (register address 10h)							
reserved	reserved	PIN 1 SEL[5]	PIN 1 SEL[4]	PIN 1 SEL[3]	PIN 1 SEL[2]	PIN 1 SEL[1]	PIN 1 SEL[0]
I/O PIN 2 CONFIG (register address 11h)							
reserved	reserved	PIN 2 SEL[5]	PIN 2 SEL[4]	PIN 2 SEL[3]	PIN 2 SEL[2]	PIN 2 SEL[1]	PIN 2 SEL[0]
I/O PIN 3 CONFIG (register address 12h)							
reserved	reserved	PIN 3 SEL[5]	PIN 3 SEL[4]	PIN 3 SEL[3]	PIN 3 SEL[2]	PIN 3 SEL[1]	PIN 3 SEL[0]
I/O PIN 4 CONFIG (register address 13h)							
reserved	reserved	PIN 4 SEL[5]	PIN 4 SEL[4]	PIN 4 SEL[3]	PIN 4 SEL[2]	PIN 4 SEL[1]	PIN 4 SEL[0]
I/O PIN 5 CONFIG (register address 14h)							
reserved	reserved	PIN 5 SEL[5]	PIN 5 SEL[4]	PIN 5 SEL[3]	PIN 5 SEL[2]	PIN 5 SEL[1]	PIN 5 SEL[0]
I/O PIN 6 CONFIG (register address 15h)							
reserved	reserved	PIN 6 SEL[5]	PIN 6 SEL[4]	PIN 6 SEL[3]	PIN 6 SEL[2]	PIN 6 SEL[1]	PIN 6 SEL[0]
I/O PIN 7 CONFIG (register address 16h)							
reserved	reserved	PIN 7 SEL[5]	PIN 7 SEL[4]	PIN 7 SEL[3]	PIN 7 SEL[2]	PIN 7 SEL[1]	PIN 7 SEL[0]

TABLE 3. Control Register Addresses

Register Name	Address Hexadecimal
EDH 0	01
EDH 1	02
EDH 2	03
ANC 0	04
ANC 1	05
ANC 2	06
ANC 3	07
ANC 4	08
ANC 5	17
ANC 6	18
FORMAT 0	0B
FORMAT 1	0C
TEST 0	0D
VIDEO INFO 0	0E
I/O PIN 0 CONFIG	0F
I/O PIN 1 CONFIG	10
I/O PIN 2 CONFIG	11
I/O PIN 3 CONFIG	12
I/O PIN 4 CONFIG	13
I/O PIN 5 CONFIG	14
I/O PIN 6 CONFIG	15
I/O PIN 7 CONFIG	16
VIDEO CONTROL 0	55
VIDEO CONTROL 1	56
REFERENCE CLOCK	67

EDH 0 (Register 01h)

The EDH Full-Field flags **F/F UES**, **F/F IDA**, **F/F IDH**, **F/F EDA** and **F/F EDH** are defined in SMPTE RP 165. The flags are updated automatically when the EDH function is enabled and data is being received.

The **EDH ENABLE** bit, when set, enables operation of the EDH generator function during SD operation. The default condition of this bit is set (ON).

The **EDH FORCE** bit, when set, causes updated EDH packets to be inserted in the parallel output data regardless of the previous condition of EDH checkwords and flags in the input serial data. This function may be used in situations where video content has been edited thus making the previous EDH information invalid. The default condition of this bit is reset (OFF).

The **CRC ERROR** bit indicates that errors in either the EDH checksums (SD) or CRC checkwords (HD) were detected in the serial input data. This bit is a combined function which indicates the presence of either EDH errors during SD operation or CRC errors during HD operation.

EDH 1 (Register 02h)

The EDH Active Picture flags **A/P UES**, **A/P IDA**, **A/P IDH**, **A/P EDA** and **A/P EDH** are defined in SMPTE RP 165. The flags are updated automatically when the EDH function is enabled and data is being received.

Specific types of CRC errors in incoming HD serial data are reported in the **CRC ERROR LUMA** and **CRC ERROR CHROMA** bits.

The **CRC REPLACE** bit, when set, causes the CRCs in the incoming data to be replaced with CRCs calculated by the CLC031A. The bit is normally reset (OFF).

EDH 2 (Register 03h)

The EDH Ancillary Data flags **ANC UES**, **ANC IDA**, **ANC IDH**, **ANC EDA** and **ANC EDH** are defined in SMPTE RP 165. The flags are updated automatically when the EDH function is enabled and data is being received.

The status of EDH flag errors in incoming SD serial data are reported in the **ffFlagError**, **apFlagError** and **ancFlagError** bits. Each of these bits is the logical-OR of the corresponding EDH and EDA flags.

ANC 0 (Address 04h)

The **V FIFO Depth[2:0]** bits control the depth of the video FIFO which precedes the parallel output data drivers. The depth can be set from 0 to 4 stages by writing the corresponding binary code into these bits. For example: to set the Video FIFO depth at two registers, load 11010XXXXb into the ANC 0 control register (where X represents the other functional bits of this register).

Note: When changing some but not all bits in a register and to retain unchanged other data previously stored in the register, read the register's contents and logically-OR this with the new data. Then write the modified data back into the register.

Flags for **ANC FIFO EMPTY**, **ANC FIFO 90% FULL**, **ANC FIFO FULL** and **ANC FIFO OVERRUN** are available in the configuration and control register set. These flags can also be assigned as outputs on the multi-function I/O port. **ANC FIFO EMPTY** when set indicates that the FIFO contains no data. **ANC FIFO 90% FULL** indicates when the FIFO is at 90% of capacity. Since it is virtually impossible for the host processor to begin extracting data from the FIFO after it has been flagged as full without the possibility of an overrun condition occurring, **ANC FIFO 90% FULL** is used as an advanced command to the host to begin extracting data from the FIFO. To be used properly, **ANC FIFO 90% FULL** should be assigned as an output on the multi-function I/O port and monitored by the host system. Otherwise, inadvertent loss of ancillary packet data could occur. **ANC FIFO FULL** when set indicates that the FIFO registers are completely filled with data.

The **ANC FIFO OVERRUN** flag indicates that an attempt to write data into a full FIFO has occurred. **ANC FIFO OVERRUN** can be reset by reading the bit's status via the ancillary/Control port. If an overrun occurs, the status of the FIFO message tracking will be invalidated. In this event, the FIFO should be flushed to reset the message tracking pointers. Any messages then in the FIFO will be lost.

The **ANC Checksum Force** bit, under certain conditions, enables the overwriting of Ancillary Data checksums received in the data. Calculation and insertion of new Ancillary Data checksums is controlled by the **ANC Checksum Force** bit. If a checksum error is detected (calculated and received checksums do not match) and the **ANC Checksum Force** bit is set, the **ANC Checksum Error** bit is set and a new checksum is inserted in the Ancillary Data replacing the previous one. If a checksum error is detected and the **ANC Checksum Force** bit is not set, the checksum mismatch is reported via the **ANC Checksum Error** bit. **ANC Checksum Error** is available as an output on the multifunction I/O port.

ANC 1 AND 2 (Addresses 05h and 06h)

The extraction of Ancillary Data packets from video data into the FIFO is controlled by the **ANC MASK[15:0]** and **ANC ID [15:0]** bits in the control registers. The **ANC ID[7:0]** register normally is set to a valid 8-bit code used for component Ancillary Data packet DID identification as specified in SMPTE 291M-1998. Similarly, **ANC ID[15:8]** normally is set to a valid 8-bit code used for component Ancillary Data packet SDID/DBN identification.

ANC 3 AND 4 (Addresses 07h and 08h)

The **ANC MASK[7:0]** is an 8-bit word that can be used to selectively control extraction of packets with specific DIDs (or DID ranges) into the FIFO. When the **ANC MASK[7:0]** is set to FFh, packets with any DID can be extracted into the FIFO. When any bit or bits of the **ANC MASK[7:0]** are set to a logic-1, the corresponding bit or bits of the **ANC ID[7:0]** are a don't-care when matching DIDs of packets being extracted. When the **ANC MASK[7:0]** is set to 00h, the ANC DID of incoming packets must match exactly, bit-for-bit the **ANC ID [7:0]** set in the control register for the packets to be extracted into the FIFO. The initial value of the **ANC MASK[7:0]** is FFh and the **ANC ID[7:0]** is 00h.

Similarly, **ANC MASK[15:8]** is an 8-bit word that can be used to selectively control extraction of packets with specific SDID/DBN (or SDID/DBN ranges) into the FIFO. Operation and use of these bits is the same as for **ANC MASK[7:0]** previously discussed.

ANC 5 (Address 17h)

The **FIFO EXTRACT ENABLE** bit in the control registers enables the device to extract or copy Ancillary Data from the video data stream and place it in the ANC FIFO. From there data may be output via the parallel ancillary port. Data extraction is enabled when this bit is set to a logic-1. This bit can be used to delay automatic extraction and therefore the output of parallel Ancillary Data. **FIFO EXTRACT ENABLE** should be asserted during an SAV or EAV to avoid timing problems with Ancillary Data extraction. Access to data in the FIFO is controlled by the **RD/WR**, **ANC/CTRL** and **A_{CLK}** control signals.

To conserve power when the Ancillary Data function is not being used, the internal Ancillary Data FIFO clock is disabled. This clock must be enabled before Ancillary Data may be replicated into the FIFO for output. **FIFO CLOCK ENABLE**, bit-6 of the **ANC 5** register (address 17h), when set, enables this clock to propagate to the FIFO. The default condition of **FIFO CLOCK ENABLE** is OFF. After enabling the internal FIFO clock by turning this bit ON, **A_{CLK}** must be toggled three (3) times to propagate the enable to the clock tree. **A_{CLK}** should remain running at all times when the ANC FIFO is in use. Otherwise, message tracking and related functions will not operate correctly.

The CLC031A can keep track of up to 8 ANC data packets in the ANC FIFO. Incoming packet length versus available space in the FIFO is also tracked. The **MSG TRACK** bit in the control registers, when set, enables tracking of packets in the FIFO. Other functions for control of packet traffic in the FIFO are **FIFO FLUSH STAT** and **MSG FLUSH STAT**. If the user wishes to handle more than 8 messages, the **MSG TRACK**

bit should be turned off (reset). The operation **FIFO FLUSH STAT** will no longer work and the function **FULL MSG AVAILABLE** will no longer be a reliable indicator that messages are available in the FIFO. The user may still effectively use the FIFO by monitoring the states of **ANC FIFO EMPTY**, **ANC FIFO FULL**, **ANC FIFO 90%FULL** and **ANC FIFO OVER-RUN**.

Setting the **FIFO FLUSH STAT** bit to a logic-1 flushes the FIFO. **FIFO FLUSH STAT** may not be set while the FIFO is being accessed (Read or Write). **FIFO FLUSH STAT** is automatically reset after this operation is complete.

When **MSG FLUSH STAT** is set to a logic-1, the oldest message packet in the FIFO is flushed when data is not being written to the FIFO. **MSG FLUSH STAT** is automatically reset after this operation is complete.

The **FULL MSG AVAILABLE** bit in the control registers, when set, notifies the host system that complete packets reside in the Ancillary Data FIFO. When this bit is not set, the messages in the FIFO are incomplete or partial. This function is not affected by **MSG TRACK**. The **FULL MSG AVAILABLE** function is most useful when mapped to the multifunction I/O port as an output.

ANC 6 (Address 18h)

The **ANC FIFO 90% FULL** flag bit indicates when the ANC FIFO is 90% full. This bit may be mapped to the multi-function I/O port. The purpose of this flag is to provide a signal which gives the host system time to begin reading from the FIFO before it has the chance to overflow. This was done because it is virtually impossible to monitor the FIFO FULL flag and begin extracting from the FIFO before an overrun condition occurs.

The **SHORT MSG DETECT** flag bit indicates when short ANC messages have been detected. i.e. An ANC header was detected before the last full message was recovered. This bit may be mapped to the multi-function I/O port.

The **ANC PARITY MASK** bit when set disables parity checking for DID and SDID words in the ANC data packet. When reset, parity checking is enabled; and, if a parity error occurs, the packet will not be extracted.

The **VANC** bit, when set, enables extraction of ANC data present in the vertical blanking interval (both active video and horizontal blanking portions of the line).

FORMAT 0 (Address 0Bh)

The CLC031A may be set to process a single video format by writing the appropriate data into the **FORMAT 0** register. The **Format Set[4:0]** bits confine the CLC031A to recognize and process only one of the fourteen specified type of SD or HD formats defined by a particular SMPTE specification. The **Format Set[4:0]** bits may not be used to confine device operation to a range of standards. The available formats and codes are detailed in [Table 4](#). Generally speaking, the **Format Set[4:0]** codes indicate or group the formats as follows: **Format Set[4]** is set for the HD data formats, reset for SD data formats. **Format Set[3]** is set for PAL data formats (with the exception of the SMPTE 274M 24-frame progressive format), reset for NTSC data formats. **Format Set[2:0]** further sub-divide the standards as given in the table.

TABLE 4. Video Raster Format Parameters

Format Code [4,3,2,1,0]	Format	Spec.	Frame Rate	Lines	Active Lines	Samples	Active Samples
00001	SDTV, 54	RP 174	60I	525	507/487*	3432	2880
00010	SDTV, 36	SMPTE 267	60I	525	507/487*	2288	1920
00011	SDTV, 27	SMPTE 125	60I	525	507/487*	1716	1440
01001	SDTV, 54	ITU-R BT 601.5	50I	625	577	3456	2880
01010	SDTV, 36	ITU-R BT 601.5	50I	625	577	2304	1920
01011	SDTV, 27	ITU-R BT 601.5	50I	625	577	1728	1440
10001	HDTV, 74.25	SMPTE 260	30I	1125	1035	2200	1920
10010	HDTV, 74.25	SMPTE 274	30I	1125	1080	2200	1920
10011	HDTV, 74.25	SMPTE 274	30P	1125	1080	2200	1920
11001	HDTV, 74.25	SMPTE 274	25I	1125	1080	2640	1920
11010	HDTV, 74.25	SMPTE 274	25P	1125	1080	2640	1920
11100	HDTV, 74.25	SMPTE 295	25I	1250	1080	2376	1920
11101	HDTV, 74.25	SMPTE 274	24P	1125	1080	2750	1920
10100	HDTV, 74.25	SMPTE 296 (1, 2)	60P	750	720	1650	1280

The **HD Only** bit when set to a logic-1 locks the CLC031A into the high definition data range and frequency. In systems designed to handle only high definition signals, enabling **HD Only** reduces the time required for the CLC031A to establish frequency lock and determine the HD format being processed.

The **SD Only** bit when set to a logic-1 locks the CLC031A into the standard definition data ranges and frequencies. In systems designed to handle only standard definition signals, enabling **SD Only** reduces the time required for the CLC031A to establish frequency lock and determine the format being processed. When **SD Only** and **HD Only** are set to logic-0, the device operates in SD/HD mode.

The **Framing Mode** bit in the **Format 0** register and **Framing Enable** in the **Video Info 0** register combine with **Framing Enable** to control the manner in which the CLC031A aligns framing. When **Framing Mode** and **Framing Enable** are both reset, the CLC031A aligns on the first valid TRS character. If another TRS occurs that is not on a word boundary, the NSP bit is set until the next TRS that is on a word boundary occurs. When **Framing Mode** is set to a logic-1, the CLC031A operates similarly to the CLC011 when NSP is tied to FE. An alternative configuration that operates identically can be achieved with the CLC031A by mapping **NSP** as an output and **Framing Enable** as an input on the Multifunction I/O bus and externally connecting them. In this case **Framing Mode** should be reset to a logic-0. When **Framing Mode** is reset and **Framing Enable** is set, the CLC031A realigns on every valid TRS. The initial state of **Framing Mode** is set following a reset or at power-on.

FORMAT 1 (Address 0Ch)

The CLC031A automatically determines the format of the incoming serial data. The result of this operation is stored in the

FORMAT 1 register. The **Format[4:0]** bits identify which of the many possible video data standards that the CLC031A can process is being received. These format codes follow the same arrangement as for the **Format Set[4:0]** bits. These formats and codes are given in [Table 4](#). Bit **Format[4]** when set indicates that HD data is being processed. When reset, SD data is indicated. **Format[3]** when set indicates that PAL data is being processed. When reset NTSC data is being processed. **Format[2:0]** correspond with one of the sub-standards given in the table. Note that the CLC031A does not distinguish or log the data rate differences between HD data at 74.25Mhz and 74.25MHz/1.001.

The **H, V, and F** bits correspond to input TRS data bits 6, 7 and 8, respectively. The meaning and function of this data is the same for both standard definition (SMPTE 125M) and high definition (SMPTE 292M luminance and colour difference) video data. Polarity is logic-1 equals HIGH-true. These bits are registered for the duration of the applicable field.

TEST 0 REGISTER (Address 0Dh)

The **Test Pattern Select** bits determine which test pattern is output when the Test Pattern Generator (TPG) mode or the Built-in Self-Test (BIST) mode is enabled. [Table 5](#) gives the codes corresponding to the various test patterns. All HD colour bar test patterns are inherently BIST data. BIST test patterns for SD are: NTSC, 27MHz, 4x3 Colour Bars and PAL, 27MHz, 4x3 PLL Pathological.

The **TPG Enable** bit when set to a logic-1 enables the Test Pattern Generator function and built-in self-test (BIST).

The **Pass/Fail** bit indicates the result of the built-in self-test. This bit is a logic-1 for a pass condition.

TABLE 5. Test Pattern Selection Codes

Test Pattern Select Word Bits >	Bit 5	Bit 4	Bit 3	Bit 2	Bit 1	Bit 0
Video Raster Standard	1=HD	1=Progressive 0=Interlaced			00=Black 01=PLL Path. 10=EQ Path. 11=Colour Bars	
	0=SD	1=PAL 0=NTSC				
1125 Line, 74.25 MHz, 30 Frame Interlaced Component (SMPTE 260M)						
Ref. Black	1	0	0	0	0	0
PLL Path.	1	0	0	0	0	1
EQ Path.	1	0	0	0	1	0
Colour Bars	1	0	0	0	1	1
1125 Line, 74.25 MHz, 30 Frame Interlaced Component (SMPTE 274M)						
Ref. Black	1	0	0	1	0	0
PLL Path.	1	0	0	1	0	1
EQ Path.	1	0	0	1	1	0
Colour Bars	1	0	0	1	1	1
1125 Line, 74.25 MHz, 25 Frame Interlaced Component (SMPTE 274M)						
Ref. Black	1	0	1	0	0	0
PLL Path.	1	0	1	0	0	1
EQ Path.	1	0	1	0	1	0
Colour Bars	1	0	1	0	1	1
1125 Line, 74.25 MHz, 25 Frame Interlaced Component (SMPTE 295M)						
Ref. Black	1	0	1	1	0	0
PLL Path.	1	0	1	1	0	1
EQ Path.	1	0	1	1	1	0
Colour Bars	1	0	1	1	1	1
1125 Line, 74.25 MHz, 30 Frame Progressive Component (SMPTE 274M)						
Ref. Black	1	1	0	0	0	0
PLL Path.	1	1	0	0	0	1
EQ Path.	1	1	0	0	1	0
Colour Bars	1	1	0	0	1	1
1125 Line, 74.25 MHz, 25 Frame Progressive Component (SMPTE 274M)						
Ref. Black	1	1	0	1	0	0
PLL Path.	1	1	0	1	0	1
EQ Path.	1	1	0	1	1	0
Colour Bars	1	1	0	1	1	1
1125 Line, 74.25 MHz, 24 Frame Progressive Component (SMPTE 274M)						
Ref. Black	1	1	1	0	0	0
PLL Path.	1	1	1	0	0	1
EQ Path.	1	1	1	0	1	0
Colour Bars	1	1	1	0	1	1
750 Line, 74.25 MHz, 60 Frame Progressive Component (SMPTE 296M)						
Ref. Black	1	1	1	1	0	0
PLL Path.	1	1	1	1	0	1
EQ Path.	1	1	1	1	1	0
Colour Bars	1	1	1	1	1	1

Test Pattern Select Word Bits >	Bit 5	Bit 4	Bit 3	Bit 2	Bit 1	Bit 0
525 Line, 30 Frame, 27 MHz, NTSC 4x3 (SMPTE 125M)						
Ref. Black	0	0	0	0	0	0
PLL Path.	0	0	0	0	0	1
EQ Path.	0	0	0	0	1	0
Colour Bars (SD BIST)	0	0	0	0	1	1
625 Line, 25 Frame, 27 MHz, PAL 4x3 (ITU-T BT.601)						
Ref. Black	0	1	0	0	0	0
PLL Path. (SD BIST)	0	1	0	0	0	1
EQ Path.	0	1	0	0	1	0
Colour Bars	0	1	0	0	1	1
525 Line, 30 Frame, 36 MHz, NTSC 16x9 (SMPTE 125M)						
Ref. Black	0	0	0	1	0	0
PLL Path.	0	0	0	1	0	1
EQ Path.	0	0	0	1	1	0
Colour Bars	0	0	0	1	1	1
625 Line, 25 Frame, 36 MHz, PAL 16x9 (ITU-T BT.601)						
Ref. Black	0	1	0	1	0	0
PLL Path.	0	1	0	1	0	1
EQ Path.	0	1	0	1	1	0
Colour Bars	0	1	0	1	1	1
525 Line, 30 Frame, 54 MHz (NTSC)						
Ref. Black	0	0	1	0	0	0
PLL Path.	0	0	1	0	0	1
EQ Path.	0	0	1	0	1	0
Colour Bars	0	0	1	0	1	1
625 Line, 25 Frame, 54 MHz (PAL)						
Ref. Black	0	1	1	0	0	0
PLL Path.	0	1	1	0	0	1
EQ Path.	0	1	1	0	1	0
Colour Bars	0	1	1	0	1	1

Note: BIST test patterns for SD are: NTSC 4x3 Colour Bars and PAL 4x3 PLL Pathological.

VIDEO INFO 0 REGISTER (Address 0Eh)

Re-synchronization of the parallel video output data with the parallel rate clock is controlled by the functions **Framing Enable**, **Framing Mode** and **NSP**. For operating details about these control bits, refer to the preceding section about **Format Registers 0 and 1** and the **Format Mode** bit. **Framing Enable** may be assigned as an input on the multi-function I/O port.

The **NSP** (New Sync Position) bit indicates that a new or out-of-place TRS character has been detected in the input data. This bit is set to a logic-1 and remains set for at least one horizontal line period or unless re-activated by a subsequent new or out-of-place TRS. It is reset by an EAV TRS character. The **EAV** (end of active video) and **SAV** (start of active video) bits track the occurrence of the corresponding TRS characters.

The **Lock Detect** is a logic-1 when the loop is locked and the CDR has acquired a phase of the incoming serial data. This bit may be programmed as an output on the multi-function I/O bus. This bit is mapped to I/O port bit 4 in the default condition.

The **VPG Filter Enable** bit when set enables operation of the Video Pattern Generator filter. Operation of this filter causes

the insertion of transition codes in the chroma and luma data of colour bar test patterns where these patterns change from one bar to the next. This filter reduces the magnitude of out-of-band frequency products which are produced by abrupt transitions in the chroma and luma data when fed to D-to-A converters and picture monitors.

The CLC031A incorporates circuitry that implements a method for handling data that has been subjected to **LSB dithering**. Data from the de-scrambler is routed for de-dithering. Control of this circuitry is via the **De-Dither Enable** bit in the **VIDEO INFO 0** control register. Recovery of data that has been dithered during the vertical blanking interval can be selectively enabled by use of the **V De-Dither Enable** bit in the **VIDEO INFO 0** control register. The initial condition of **De-Dither Enable** and **V De-Dither Enable** is OFF.

VIDEO CONTROL 0 (Register Address 55h)

The **EXTERNAL V_{CLK}** bit is a special application function which enables use of an external VCXO as a substitute for the internally generated V_{CLK}. Additional circuitry is enabled within the CLC031A which provides phase-frequency detection and control voltage output for the VCXO. An external loop filter and voltage amplifier are required to interface the control voltage output to the VCXO frequency control input. When

this function is used, the R_{BB} output function is changed from the bias supply output to the control voltage output of the phase-frequency detector. The V_{CLK} output changes function, becoming the input for the VCXO signal. Use of this function and required external support circuitry is explained in the *Application Information* section.

The **SYNC DETECT ENABLE** bit, when set, enables detection of TRS characters. This bit is normally set (ON).

The **LSB CLIP ENABLE** bit, when set, causes the two LSBs of TRS characters to be set to 00b as described in ITU-R BT. 601. This function is normally set (ON).

The **NRZI ENABLE** bit, when set, enables data to be converted from NRZI to NRZ. This bit is normally set (ON).

The **DE-SCRAMBLE ENABLE** bit, when set, enables descrambling of the incoming data according to requirements of SMPTE 259M or SMPTE 292M. This bit is normally set (ON).

CAUTION: The default state of this register is 36h. If any of the normal operating features of the descrambler are turned off, this register's default data must be restored to resume normal device operation.

REFERENCE CLOCK REGISTER (Address 67h)

The **Reference Clock** register controls operation of the CDR reference clock source. The **CLKEN** bit when reset to a logic-0 enables the oscillator signal to be used by the CLC031A as a reference. The default state of this bit at power-on is enabled. In general, this function and bit should not be disabled. The **INT_OSC EN** bit enables the internal crystal oscillator amplifier. By default this bit is a logic-0 and is therefore inac-

tive at power-on. The device expects an external 27MHz reference reference clock source to be connected to the **XTALI/Ext Clk** pin and activated at power-on.

I/O PIN 0 THROUGH 7 CONFIGURATION REGISTERS (Addresses 0Fh through 16h)

The **I/O Pin Configuration Registers** are used to map individual bits of the multi-function I/O port to selected bits of the Configuration and Control Registers. *Table 6* gives the pin select codes for the Configuration and Control register functions that may be mapped to the port. **Pin[n] Select [5]** controls whether the port pin is input or output. The port pin will be an input when this bit is set and an output when reset. Input-only functions may not be configured as outputs and vice versa. The remaining five **Pin[n] Select [4:0]** bits identify the particular Control Register bit to be mapped.

Example: Program, via the AD port, I/O port bit 0 as output for the CRC Luma Error bit in the control registers.

1. Set **ANC/CTRL** to a logic-low.
2. Set **RD/WR** to a logic-low.
3. Present 00Fh to **AD[9:0]** as the **I/O PIN 0 CONFIG** register address.
4. Toggle A_{CLK} .
5. Present 310h to **AD[9:0]** as the register data, the bit address of the CRC Luma Error bit in the control registers.
6. Toggle A_{CLK} .

TABLE 6. Control Register Bit, Pin[n] SEL[5:0] Codes for I/O Port Pin Mapping

Register Bit	Pin[n] SEL[5:0] Codes							I/P or O/P	Power-On Status
	[5]	[4]	[3]	[2]	[1]	[0]	HEX		
reserved	0	0	0	0	0	0	00	O/P	
FF Flag Error	0	0	0	0	0	1	01	O/P	
AP Flag Error	0	0	0	0	1	0	02	O/P	
ANC Flag Error	0	0	0	0	1	1	03	O/P	
CRC Error (SD/HD)	0	0	0	1	0	0	04	O/P	I/O Port Bit 5
Addresses 05h and 06h are reserved									
ANC FIFO 90% FULL	0	0	0	1	1	1	07	O/P	
SHORT MSG DETECT	0	0	1	0	0	0	08	O/P	
FULL MSG AVAIL	0	0	1	0	0	1	09	O/P	
Addresses 0Ah through 0Ch are reserved									
SAV	0	0	1	1	0	1	0D	O/P	
EAV	0	0	1	1	1	0	0E	O/P	I/O Port Bit 7
NSP	0	0	1	1	1	1	0F	O/P	
CRC Luma Error	0	1	0	0	0	0	10	O/P	
CRC Chroma Error	0	1	0	0	0	1	11	O/P	
F	0	1	0	0	1	0	12	O/P	I/O Port Bit 0
V	0	1	0	0	1	1	13	O/P	I/O Port Bit 1
H	0	1	0	1	0	0	14	O/P	I/O Port Bit 2
Format[0]	0	1	0	1	0	1	15	O/P	
Format[1]	0	1	0	1	1	0	16	O/P	
Format[2]	0	1	0	1	1	1	17	O/P	
Format[3]	0	1	1	0	0	0	18	O/P	
Format[4]	0	1	1	0	0	1	19	O/P	I/O Port Bit 3 (SD/HD)
FIFO Full	0	1	1	0	1	0	1A	O/P	
FIFO Empty	0	1	1	0	1	1	1B	O/P	I/O Port Bit 6
Lock Detect	0	1	1	1	0	0	1C	O/P	I/O Port Bit 4
Pass/Fail	0	1	1	1	0	1	1D	O/P	
FIFO Overrun	0	1	1	1	1	0	1E	O/P	
ANC Chksum Error	0	1	1	1	1	1	1F	O/P	
EDH Force	1	0	0	0	0	0	20	I/P	
Test Pattern Select[0]	1	0	0	0	0	1	21	I/P	
Test Pattern Select[1]	1	0	0	0	1	0	22	I/P	
Test Pattern Select[2]	1	0	0	0	1	1	23	I/P	
Test Pattern Select[3]	1	0	0	1	0	0	24	I/P	
Test Pattern Select[4]	1	0	0	1	0	1	25	I/P	
Test Pattern Select[5]	1	0	0	1	1	0	26	I/P	
EDH Enable	1	0	0	1	1	1	27	I/P	
TPG Enable	1	0	1	0	0	0	28	I/P	
Addresses 29h through 2Bh are reserved									
VPG Filter Enable	1	0	1	1	0	0	2C	I/P	
De-Dither Enable	1	0	1	1	0	1	2D	I/P	
Framing Enable	1	0	1	1	1	0	2E	I/P	
FIFO Extract Enable	1	0	1	1	1	1	2F	I/P	

Pin Descriptions

Pin	Name	Description
1	AD9	Ancillary Data Output, Control Data Input
2	AD8	Ancillary Data Output, Control Data Input
3	AD7	Ancillary Data Output, Control Data Input
4	AD6	Ancillary Data Output, Control Data Input
5	AD5	Ancillary Data Output, Control Data Input
6	V _{SSD}	Negative Power Supply Input (2.5V supply, Digital Logic)
7	AD4	Ancillary Data Output, Control Data Input
8	AD3	Ancillary Data Output, Control Data Input
9	AD2	Ancillary Data Output, Control Data Input
10	AD1	Ancillary Data Output, Control Data Input
11	AD0	Ancillary Data Output, Control Data Input
12	V _{DDD}	Positive Power Supply Input (2.5V supply, Digital Logic)
13	A _{CLK}	ancillary/Control Clock Input
14	IO7	Multi-Function I/O Port
15	IO6	Multi-Function I/O Port
16	IO5	Multi-Function I/O Port
17	IO4	Multi-Function I/O Port
18	IO3	Multi-Function I/O Port
19	IO2	Multi-Function I/O Port
20	V _{SSIO}	Negative Power Supply Input (3.3V supply, I/O)
21	DV19	Parallel Video Output (HD=Luma)
22	DV18	Parallel Video Output (HD=Luma)
23	DV17	Parallel Video Output (HD=Luma)
24	DV16	Parallel Video Output (HD=Luma)
25	DV15	Parallel Video Output (HD=Luma)
26	V _{DDIO}	Positive Power Supply Input (3.3V supply, I/O)
27	DV14	Parallel Video Output (HD=Luma)
28	DV13	Parallel Video Output (HD=Luma)
29	DV12	Parallel Video Output (HD=Luma)
30	DV11	Parallel Video Output (HD=Luma)
31	DV10	Parallel Video Output (HD=Luma)
32	V _{SSD}	Negative Power Supply Input (2.5V supply, Digital Logic)
33	V _{DDD}	Positive Power Supply Input (2.5V supply, Digital Logic)
34	DV9	Parallel Video Output (HD=Chroma, SD=Luma & Chroma)
35	DV8	Parallel Video Output (HD=Chroma, SD=Luma & Chroma)
36	DV7	Parallel Video Output (HD=Chroma, SD=Luma & Chroma)
37	DV6	Parallel Video Output (HD=Chroma, SD=Luma & Chroma)
38	DV5	Parallel Video Output (HD=Chroma, SD=Luma & Chroma)
39	V _{SSD}	Negative Power Supply Input (2.5V supply, Digital Logic)
40	DV4	Parallel Video Output (HD=Chroma, SD=Luma & Chroma)
41	DV3	Parallel Video Output (HD=Chroma, SD=Luma & Chroma)
42	DV2	Parallel Video Output (HD=Chroma, SD=Luma & Chroma)
43	DV1	Parallel Video Output (HD=Chroma, SD=Luma & Chroma)
44	DV0	Parallel Video Output (HD=Chroma, SD=Luma & Chroma)
45	IO1	Multi-Function I/O Port
46	IO0	Multi-Function I/O Port
47	V _{SSIO}	Negative Power Supply Input (3.3V supply, I/O)
48	V _{DDIO}	Positive Power Supply Input (3.3V supply, I/O)

Pin	Name	Description
49	RESET	Manual Reset Input (High True)
50	V _{CLK}	Parallel Video Data Clock Output
51	V _{DDPLL}	Positive Power Supply Input (2.5V supply, PLL)
52	V _{SSPLL}	Negative Power Supply Input (2.5V supply, PLL)
53	R _{REF}	Current Reference Resistor
54	R _{BB}	SDI Bias Supply Resistor
55	V _{SSSI}	Negative Power Supply Input (3.3V supply, Serial Input)
56	$\overline{\text{SDI}}$	Serial Data Complement Input
57	SDI	Serial Data True Input
58	V _{DDSI}	Positive Power Supply Input (3.3V supply, Serial Input)
59	V _{SSIO}	Negative Power Supply Input (3.3V supply, I/O)
60	XTALI/EXT CLK	Crystal or External 27MHz Clock Input
61	XTALo	Crystal (Oscillator Output)
62	V _{DDD}	Positive Power Supply Input (2.5V supply, Digital Logic)
63	$\overline{\text{ANC/CTRL}}$	ancillary/Control Data Port Function Control Input
64	$\overline{\text{RD/WR}}$	ancillary/Control Data Port Read/Write Control Input

Note: All LVCMOS inputs have internal pull-down devices except VCLK and ACLK.

Application Information

A typical application circuit for the CLC031A is shown in the Application Circuit diagram. This circuit demonstrates the capabilities of the CLC031A and allows its evaluation in a native configuration. An assembled demonstration board is available, part number SD131EVK. The board may be ordered through any of National's sales offices. Complete circuit board layouts and schematics for the SD131EVK are available on National's WEB site. For latest availability information, please see: www.national.com/appinfo/interface.

PCB LAYOUT AND POWER SYSTEM BYPASS RECOMMENDATIONS

Circuit board layout and stack-up for the CLC031A should be designed to provide noise-free power to the device. Good layout practice also will separate high frequency or high-level inputs and outputs from low-level inputs to minimize unwanted stray noise pickup, feedback and interference. Power system performance may be greatly improved by using thin dielectrics (4 to 10 mils) for power/ground sandwiches. This increases the intrinsic capacitance of the PCB power system which improves power supply filtering, especially at high frequencies, and makes the value and placement of external bypass capacitors less critical. External bypass capacitors should include both RF ceramic and tantalum electrolytic types. RF capacitors may use values in the range 0.01 μF to 0.1 μF . Tantalum capacitors may be in the range 2.2 μF to 10 μF . Voltage rating for tantalum capacitors should be at least 5X the power supply voltage being used. It is recommended practice to use two vias at each power pin of the CLC031A as well as all RF bypass capacitor terminals. Dual vias reduce the interconnect inductance by up to half, thereby extending the effective frequency range of the bypass components.

The outer layers of the PCB may be flooded with additional V_{SS} (ground) plane. These planes will improve shielding and isolation as well as increase the intrinsic capacitance of the power supply plane system. Naturally, to be effective, these planes must be tied to the V_{SS} power supply plane at frequent intervals with vias. Frequent via placement also improves signal integrity on signal transmission lines by providing short paths for image currents which reduces signal distortion. The

planes should be pulled back from all transmission lines and component mounting pads a distance equal to the width of the widest transmission line or the thickness of the dielectric separating the transmission line from the internal power or ground plane(s) whichever is greater. Doing so minimizes effects on transmission line impedances and reduces unwanted parasitic capacitances at component mounting pads.

In especially noisy power supply environments, such as is often the case when using switching power supplies, separate filtering may be used at the CLC031A's PLL and serial input power pins. The CLC031A was designed for this situation. The I/O, digital section, PLL and serial input power supply feeds are independent (see pinout description table and pinout drawing for details). Supply filtering may take the form of L-section or pi-section, L-C filters in series with these V_{DD} inputs. Such filters are available in a single package from several manufacturers. Device power supplies must be either sequenced as described in [POWER SUPPLIES, POWER-ON-RESET AND RESET INPUT](#) and ideally should be applied simultaneously as from a common source.

MAINTAINING OUTPUT DATA INTEGRITY

The way in which the TRS and other video data characters are specified and are therefore output in parallel form can result in the simultaneous switching of many of the CLC031A's CMOS outputs. Such switching can lead to the production of output high level droop or low level ground bounce. Given in the specifications, V_{OLP} is the peak output LOW voltage or ground bounce and V_{OHV} is the lowest output HIGH voltage or output droop that may occur under dynamic simultaneous output switching conditions. V_{OHV} and V_{OLP} are measured with respect to reference ground. Careful attention to PCB layout, power pin connections to the power planes and timing of the output data clocking can reduce these effects. Consideration must also be given to the timing allocated to external circuits which sample the outputs.

The effects of simultaneous output switching on output levels may be minimized by adopting good PCB layout and data output timing practices, especially critical at HD data rates. The power pins feeding the I/O should have low inductance connections to the power and ground planes. It is recommended that these connections use at least two vias per

power or ground pin. Short interconnecting traces consistent with good layout practices and soldering rules must be used. Sampling or clocking of data by external devices should be so timed as to take maximum advantage of the steady-state portion of the parallel output data interval. The CLC031A is designed so that video data will be stable at the positive-going transition of V_{CLK} . Data should not be sampled close to the data transition intervals associated with the negative-going clock edge. The specified propagation delay and clock to data timing parameters must be observed. When data is being sampled from the video data port together with the ANC port and/or I/O port, it is recommended that the sampling clocks be synchronized with the video clock, V_{CLK} , to minimize possible effects from ground bounce or output droop on sampled signal levels.

PROCESSING NON-SUPPORTED RASTER FORMATS

The number and type of HD raster formats has proliferated since the CLC031A was designed. Though not specifically capable of fully or automatically processing these new formats, the CLC031A may still be capable of deserializing them. The user is encouraged to experiment with processing these formats, keeping in mind that the CLC031A has not been tested to handle formats other than those detailed in [Table 4](#). Therefore, the results from attempts to process non-supported formats is not guaranteed. The following guidelines concerning device setup are provided to aid the user in configuring the CLC031A to attempt limited processing of these other raster formats.

In general, the device is configured to defeat its automatic format detection function and to limit operation to a general HD format. (The user should consult [Table 4](#) for guidance on

the format groups similar to the non-supported one to be processed). Since most non-supported formats are in the HD group, the CLC031A should be configured to operate in HD-ONLY mode by setting bit-5 of the FORMAT 0 register (address 0Bh). Also, the device should be further configured by loading the FORMAT SET[4:0] bits of this register with the general HD sub-format code. In addition, since control data is being written to the port, AD[9:8] must be driven as 11b. The complete data word for this general HD sub-format code with HD-ONLY bit set is 33Fh. Since this format differs from those in the table, the EAV/SAV indicators are disabled. Without these indicators, line numbering and CRC processing are disabled and ANC data extraction will not function. Output video chroma and luma data will be word-aligned. Post-processing of the parallel data output from the CLC031A will be needed to implement CRC checking or line number tracking.

USING EXTERNAL VCXO FOR VCLK

The **EXTERNAL V_{CLK}** bit of **VIDEO CONTROL 0** (register address 55h) is a special application function which enables use of an external VCXO as a substitute for the internally generated V_{CLK} . Additional circuitry is enabled within the CLC031A which provides phase-frequency detection and control voltage output for the VCXO. An external loop filter and voltage amplifier are required to interface the control voltage output to the VCXO frequency control input. When this function is used, the **R_{BB}** output function is changed from the bias supply output to the control voltage output of the phase-frequency detector. The V_{CLK} output changes function, becoming the input for the VCXO signal.

[Figure 7](#) shows an example using dual VCXOs for V_{CLK} to handle both standard and high definition video.

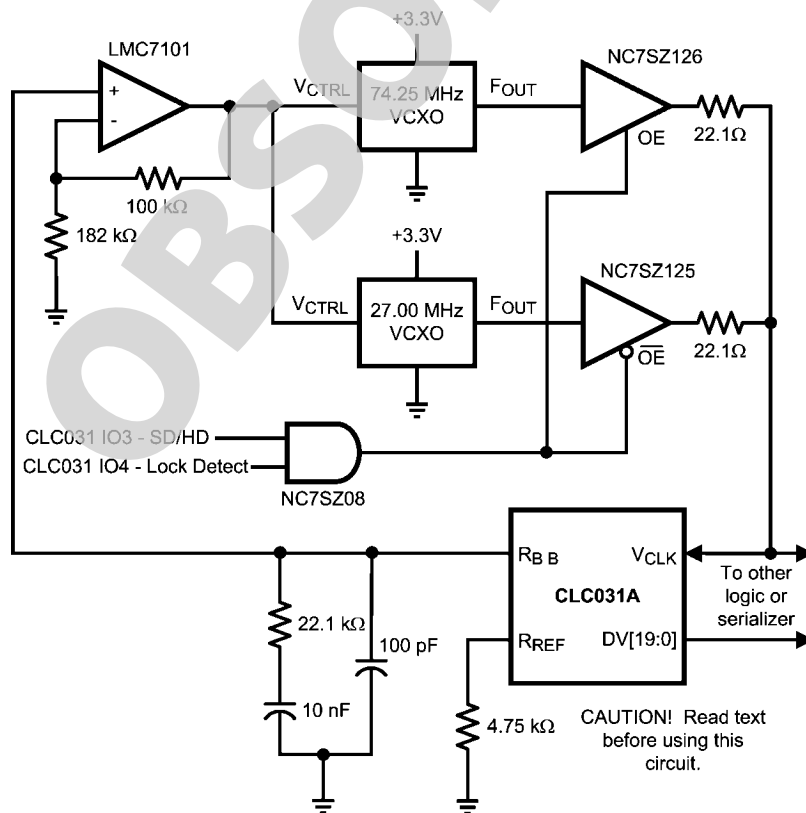

20020114

FIGURE 7. Using Dual VCXOs for VCLK Example

The control voltage output from R_{BB} is externally filtered by the loop filter consisting of a 22.1k Ω resistor in series with a 10nF capacitor, combined in parallel with a 100pF capacitor. This gives a loop bandwidth of 1.5kHz. Since the control voltage is limited to around 2.1V, it requires a level shifter to get the entire pull range on the VCXO. National's LMC7101 is recommended with 100k Ω and 182k Ω resistors as shown in [Figure 7](#) to provide a gain of 1.55, sufficient to drive a 3.3V VCXO.

Recommended VCXOs from SaRonix (141 Jefferson Drive, Menlo Park, CA 94025, USA) include the ST1308AAB-74.25 for high definition and the ST1307BAB-27.00 for standard definition. Dual VCXOs require some supporting logic to select the appropriate VCXO. This requires the use of **Format [4]** (SD/HD) and **Lock Detect**, which are mapped at power-on to I/O Port Bit 3 and I/O Port Bit 4, respectively. These two

signals pass through an AND gate (Fairchild Semiconductor's NC7SZ08 or similar). Its output is high when both Lock Detect and Format[4] are high, which indicates a valid high-definition signal is present. The VCXOs are buffered to control the transition times and to allow easy selection. The output of the AND gate is used to control the Output Enable (OE) function of the buffers. The 74.25MHz VCXO is buffered with the NC7SZ126 with the AND gate output connected to the OE pin of the NC7SZ126, and the 27.00MHz VCXO is buffered with the NC7SZ125 with the AND gate output connected to the \overline{OE} pin of the NC7SZ125. This circuit uses the 27.00MHz VCXO as default and enables the 74.25MHz VCXO when a valid high-definition signal is present. The outputs from the buffers are daisy-chained together and sent to the CLC031A's V_{CLK} in addition to other devices, such as the CLC030 serializer.

OBSOLETE

Physical Dimensions inches (millimeters) unless otherwise noted

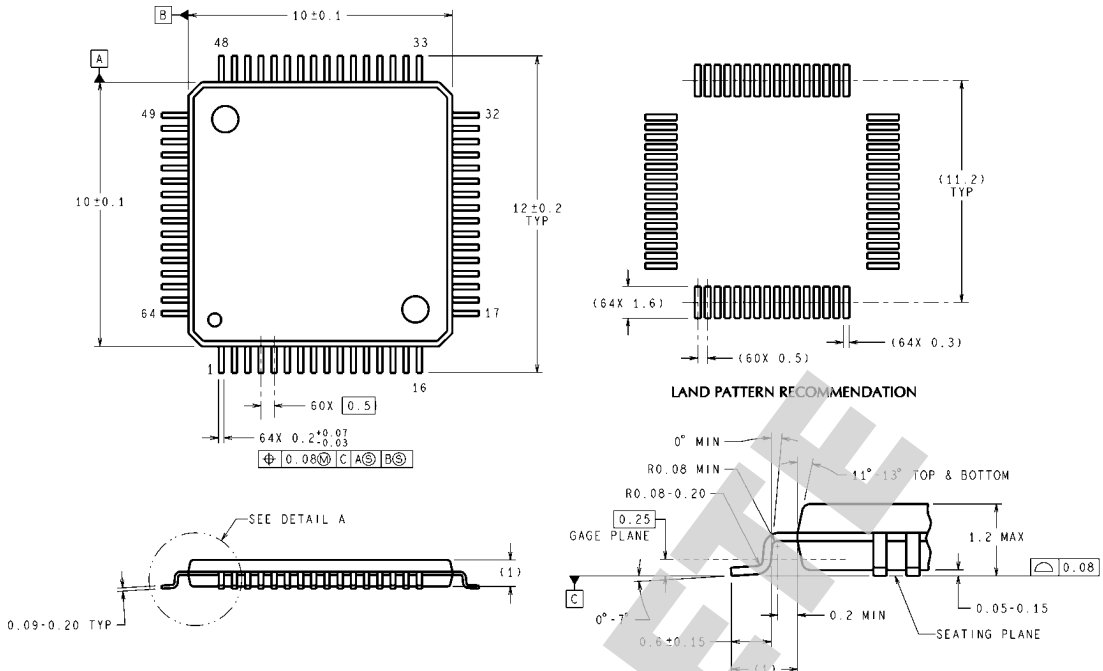

DIMENSIONS ARE IN MILLIMETERS
DIMENSIONS IN () FOR REFERENCE ONLY

DETAIL A
TYPICAL

VEC64A (Rev B)

64-Pin TQPF
Order Number CLC031AVEC
NS Package Number VEC-64A

OBSOLETE

Notes

For more National Semiconductor product information and proven design tools, visit the following Web sites at:
www.national.com

Products		Design Support	
Amplifiers	www.national.com/amplifiers	WEBENCH® Tools	www.national.com/webench
Audio	www.national.com/audio	App Notes	www.national.com/appnotes
Clock and Timing	www.national.com/timing	Reference Designs	www.national.com/refdesigns
Data Converters	www.national.com/adc	Samples	www.national.com/samples
Interface	www.national.com/interface	Eval Boards	www.national.com/evalboards
LVDS	www.national.com/lvds	Packaging	www.national.com/packaging
Power Management	www.national.com/power	Green Compliance	www.national.com/quality/green
Switching Regulators	www.national.com/switchers	Distributors	www.national.com/contacts
LDOs	www.national.com/ldo	Quality and Reliability	www.national.com/quality
LED Lighting	www.national.com/led	Feedback/Support	www.national.com/feedback
Voltage References	www.national.com/vref	Design Made Easy	www.national.com/easy
PowerWise® Solutions	www.national.com/powerwise	Applications & Markets	www.national.com/solutions
Serial Digital Interface (SDI)	www.national.com/sdi	Mil/Aero	www.national.com/milaero
Temperature Sensors	www.national.com/tempensors	SolarMagic™	www.national.com/solarmagic
PLL/VCO	www.national.com/wireless	PowerWise® Design University	www.national.com/training

THE CONTENTS OF THIS DOCUMENT ARE PROVIDED IN CONNECTION WITH NATIONAL SEMICONDUCTOR CORPORATION ("NATIONAL") PRODUCTS. NATIONAL MAKES NO REPRESENTATIONS OR WARRANTIES WITH RESPECT TO THE ACCURACY OR COMPLETENESS OF THE CONTENTS OF THIS PUBLICATION AND RESERVES THE RIGHT TO MAKE CHANGES TO SPECIFICATIONS AND PRODUCT DESCRIPTIONS AT ANY TIME WITHOUT NOTICE. NO LICENSE, WHETHER EXPRESS, IMPLIED, ARISING BY ESTOPPEL OR OTHERWISE, TO ANY INTELLECTUAL PROPERTY RIGHTS IS GRANTED BY THIS DOCUMENT.

TESTING AND OTHER QUALITY CONTROLS ARE USED TO THE EXTENT NATIONAL DEEMS NECESSARY TO SUPPORT NATIONAL'S PRODUCT WARRANTY. EXCEPT WHERE MANDATED BY GOVERNMENT REQUIREMENTS, TESTING OF ALL PARAMETERS OF EACH PRODUCT IS NOT NECESSARILY PERFORMED. NATIONAL ASSUMES NO LIABILITY FOR APPLICATIONS ASSISTANCE OR BUYER PRODUCT DESIGN. BUYERS ARE RESPONSIBLE FOR THEIR PRODUCTS AND APPLICATIONS USING NATIONAL COMPONENTS. PRIOR TO USING OR DISTRIBUTING ANY PRODUCTS THAT INCLUDE NATIONAL COMPONENTS, BUYERS SHOULD PROVIDE ADEQUATE DESIGN, TESTING AND OPERATING SAFEGUARDS.

EXCEPT AS PROVIDED IN NATIONAL'S TERMS AND CONDITIONS OF SALE FOR SUCH PRODUCTS, NATIONAL ASSUMES NO LIABILITY WHATSOEVER, AND NATIONAL DISCLAIMS ANY EXPRESS OR IMPLIED WARRANTY RELATING TO THE SALE AND/OR USE OF NATIONAL PRODUCTS INCLUDING LIABILITY OR WARRANTIES RELATING TO FITNESS FOR A PARTICULAR PURPOSE, MERCHANTABILITY, OR INFRINGEMENT OF ANY PATENT, COPYRIGHT OR OTHER INTELLECTUAL PROPERTY RIGHT.

LIFE SUPPORT POLICY

NATIONAL'S PRODUCTS ARE NOT AUTHORIZED FOR USE AS CRITICAL COMPONENTS IN LIFE SUPPORT DEVICES OR SYSTEMS WITHOUT THE EXPRESS PRIOR WRITTEN APPROVAL OF THE CHIEF EXECUTIVE OFFICER AND GENERAL COUNSEL OF NATIONAL SEMICONDUCTOR CORPORATION. As used herein:

Life support devices or systems are devices which (a) are intended for surgical implant into the body, or (b) support or sustain life and whose failure to perform when properly used in accordance with instructions for use provided in the labeling can be reasonably expected to result in a significant injury to the user. A critical component is any component in a life support device or system whose failure to perform can be reasonably expected to cause the failure of the life support device or system or to affect its safety or effectiveness.

National Semiconductor and the National Semiconductor logo are registered trademarks of National Semiconductor Corporation. All other brand or product names may be trademarks or registered trademarks of their respective holders.

Copyright© 2011 National Semiconductor Corporation

For the most current product information visit us at www.national.com



www.national.com

**National Semiconductor
Americas Technical
Support Center**

Email: support@nsc.com
Tel: 1-800-272-9959

**National Semiconductor Europe
Technical Support Center**

Email: europe.support@nsc.com

**National Semiconductor Asia
Pacific Technical Support Center**

Email: ap.support@nsc.com

**National Semiconductor Japan
Technical Support Center**

Email: jpn.feedback@nsc.com