

MC68HC11F1

MC68HC11FC0

Technical Summary

8-Bit Microcontroller

1 Introduction

The MC68HC11F1 is a high-performance member of the M68HC11 family of microcontroller units (MCUs). High-speed expanded systems required the development of this chip with its extra input/output (I/O) ports, an increase in static RAM (one Kbyte), internal chip-select functions, and a non-multiplexed bus which reduces the need for external interface logic. The timer, serial I/O, and analog-to-digital (A/D) converter enable functions similar to those found in the MC68HC11E9.

The MC68HC11FC0 is a low cost, high-speed derivative of the MC68HC11F1. It does not have EEPROM or an analog-to-digital converter. The MC68HC11FC0 can operate at bus speeds as high as six MHz.

This document provides a brief overview of the structure, features, control registers, packaging information and availability of the MC68HC11F1 and MC68HC11FC0. For detailed information on M68HC11 subsystems, programming and the instruction set, refer to the *M68HC11 Reference Manual* (M68HC11RM/AD).

1.1 Features

- MC68HC11 CPU
- 512 Bytes of On-Chip Electrically Erasable Programmable ROM (EEPROM) with Block Protect (MC68HC11F1 only)
- 1024 Bytes of On-Chip RAM (All Saved During Standby)
- Enhanced 16-Bit Timer System
 - 3 Input Capture (IC) Functions
 - 4 Output Compare (OC) Functions
 - 4th IC or 5th OC (Software Selectable)
- On-Board Chip-Selects with Clock Stretching
- Real-Time Interrupt Circuit
- 8-Bit Pulse Accumulator
- Synchronous Serial Peripheral Interface (SPI)
- Asynchronous Nonreturn to Zero (NRZ) Serial Communication Interface (SCI)
- Power saving STOP and WAIT Modes
- Eight-Channel 8-Bit A/D Converter (MC68HC11F1 only)
- Computer Operating Properly (COP) Watchdog System and Clock Monitor
- Bus Speeds of up to 6 MHz for the MC68HC11FC0 and up to 5 MHz for the MC68HC11F1
- 68-Pin PLCC (MC68HC11F1 only), 64-Pin QFP (MC68HC11FC0 only), and 80-pin TQFP package options



1.2 Ordering Information

The following devices all have 1024 bytes of RAM. In addition, the MC68HC11F1 devices have 512 bytes of EEPROM. None of the devices contain on-chip ROM.

Table 1 MC68HC11F1 Standard Device Ordering Information

Package	Temperature	Frequency	MC Order Number	
80-Pin Thin Quad Flat Pack (TQFP) (14 mm X 14 mm, 1.4 mm thick)	0° to +70°	5 MHz	MC68HC11F1PU5	
	-40° to +85°C	2 MHz	MC68HC11F1CPU2	
		3 MHz	MC68HC11F1CPU3	
		4 MHz	MC68HC11F1CPU4	
		5 MHz	MC68HC11F1CPU5	
	- 40° to + 105° C	2 MHz	MC68HC11F1VPU2	
		3 MHz	MC68HC11F1VPU3	
		4 MHz	MC68HC11F1VPU4	
	- 40° to + 125° C	2 MHz	MC68HC11F1MPU2	
		3 MHz	MC68HC11F1MPU3	
		4 MHz	MC68HC11F1MPU4	
	68-Pin PLCC	0° to +70°	5 MHz	MC68HC11F1FN5
		- 40° to + 85° C	2 MHz	MC68HC11F1CFN2
3 MHz			MC68HC11F1CFN3	
4 MHz			MC68HC11F1CFN4	
5 MHz			MC68HC11F1CFN5	
- 40° to + 105° C		2 MHz	MC68HC11F1VFN2	
		3 MHz	MC68HC11F1VFN3	
		4 MHz	MC68HC11F1VFN4	
- 40° to + 125° C		2 MHz	MC68HC11F1MFN2	
		3 MHz	MC68HC11F1MFN3	
		4 MHz	MC68HC11F1MFN4	

Table 2 MC68HC11F1 Extended Voltage (3.0 to 5.5 V) Device Ordering Information

Package	Temperature	Frequency	MC Order Number
68-Pin Plastic Leaded Chip Carrier (PLCC)	0° to +70°C	3 MHz	MC68L11F1FN3
	-40° to +85°C	3 MHz	MC68L11F1CFN3
80-Pin Thin Quad Flat Pack (TQFP)	0° to +70°C	3 MHz	MC68L11F1PU3
	-40° to +85°C	3 MHz	MC68L11F1CPU3

Freescale Semiconductor, Inc.

Table 3 MC68HC11FC0 Standard Device Ordering Information

Package	Temperature	Frequency	MC Order Number
64-Pin Quad Flat Pack (QFP)	-40° to +85°C	4 MHz	MC68HC11FC0CFU4
		5 MHz	MC68HC11FC0CFU5
	0° to 70° C	6 MHz	MC68HC11FC0FU6
80-Pin Thin Quad Flat Pack (TQFP)	-40° to +85°C	4 MHz	MC68HC11FC0CPU4
		5 MHz	MC68HC11FC0CPU5
	0° to 70° C	6 MHz	MC68HC11FC0PU6

Table 4 MC68HC11FC0 Extended Voltage (3.0 to 5.5 V) Device Ordering Information

Package	Temperature	Frequency	MC Order Number
64-Pin Quad Flat Pack (QFP)	-0° to +70°C	3 MHz	MC68L11FC0FU3
		4 MHz	MC68L11FC0FU4
80-Pin Thin Quad Flat Pack (TQFP)		3 MHz	MC68L11FC0PU3
		4 MHz	MC68L11FC0PU4

Freescale Semiconductor, Inc.

TABLE OF CONTENTS

Section	Page
1 Introduction	1
1.1 Features	1
1.2 Ordering Information	2
1.3 Block Diagrams	6
2 Pin Assignments and Signal Descriptions	8
2.1 MC68HC11F1 Pin Assignments	8
2.2 MC68HC11FC0 Pin Assignments	10
2.3 Pin Descriptions	12
3 Control Registers	14
3.1 MC68HC11F1 Control Registers	14
3.2 MC68HC11FC0 Control Registers	16
4 Operating Modes and System Initialization	18
4.1 Operating Modes	18
4.2 Memory Maps	19
4.3 System Initialization Registers	20
5 Resets and Interrupts	25
5.1 Interrupt Sources	25
5.2 Reset and Interrupt Registers	26
6 Electrically Erasable Programmable ROM	29
6.1 EEPROM Operation	29
6.2 EEPROM Registers	29
6.3 EEPROM Programming and Erasure	31
6.4 CONFIG Register Programming	32
7 Parallel Input/Output	33
7.1 Port A	33
7.2 Port B	33
7.3 Port C	33
7.4 Port D	33
7.5 Port E	33
7.6 Port F	33
7.7 Port G	34
7.8 Parallel I/O Registers	34
8 Chip-Selects	38
8.1 Chip-Select Operation	38
8.2 Chip-Select Registers	38
9 Serial Communications Interface (SCI)	42
9.1 SCI Block Diagrams	42
9.2 SCI Registers	44
10 Serial Peripheral Interface	49
10.1 SPI Block Diagram	49
10.2 SPI Registers	50
11 Analog-to-Digital Converter	53
11.1 Input Pins	54
11.2 Conversion Sequence	54
11.3 A/D Registers	55
12 Main Timer	57
12.1 Timer Operation	57
12.2 Timer Registers	59
13 Pulse Accumulator	64
13.1 Pulse Accumulator Block Diagram	64
13.2 Pulse Accumulator Registers	64

Freescale Semiconductor, Inc.

REGISTER INDEX

Register		Address	Page
ADCTL	A/D Control/Status	\$1030	55
BAUD	Baud Rate.....	\$102B	44
BPROT	Block Protect.....	\$1035	29
CFORC	Timer Force Compare.....	\$100B	59
CONFIG	EEPROM Mapping, COP, EEPROM Enables	\$103F	24, 28, 30
COPRST	Arm/Reset COP Timer Circuitry.....	\$103A	27
CSCTL	Chip-Select Control.....	\$105D	39
CSGADR.....	General-Purpose Chip-Select Address Register	\$105E	40
CSGSIZ.....	General-Purpose Chip-Select Size Register	\$105F	40
CSSTRH	Clock Stretching.....	\$105C	38
DDRA	Port A Data Register.....	\$1001	34
DDRC.....	Data Direction Register for Port C	\$1007	35
DDRD.....	Data Direction Register for Port D	\$1009	36
DDRG.....	Data Direction Register for Port G	\$1003	35
HPRIO.....	Highest Priority Interrupt and Miscellaneous	\$103C	20, 27
INIT	RAM and I/O Mapping	\$103D	21, 22
OC1D	Output Compare 1 Data	\$100D	59
OC1M.....	Output Compare 1 Mask	\$100C	59
OPT2.....	System Configuration Option Register 2	\$1038	22, 36, 52
OPTION	System Configuration Options	\$1039	23, 26, 56
PACNT	Pulse Accumulator Count	\$1027	66
PACTL.....	Pulse Accumulator Control	\$1026	63, 65
PORTA.....	Port A Data	\$1000	34
PORTB.....	Port B Data	\$1004	35
PORTC.....	Port C Data	\$1006	35
PORTD.....	Port D Data	\$1008	36
PORTE.....	Port E Data	\$100A	36
PORTF.....	Port F Data	\$1005	35
PORTG.....	Port G Data.....	\$1002	34
PPROG	EEPROM Programming Control	\$103B	30
SCCR1	SCI Control 1	\$102C	46
SCCR2.....	SCI Control 2	\$102D	46
SCDR	Serial Communications Data Register.....	\$102F	48
SCSR	SCI Status.....	\$102E	47
SPCR	Serial Peripheral Control	\$1028	50
SPDR	SPI Data	\$102A	51
SPSR	Serial Peripheral Status	\$1029	51
TCNT.....	Timer Count	\$100E, \$100F	59
TCTL1	Timer Control 1	\$1020	60
TCTL2	Timer Control 2	\$1021	61
TEST1	Factory Test	\$103E	24
TFLG1.....	Timer Interrupt Flag 1	\$1023	61
TFLG2.....	Timer Interrupt Flag 2	\$1025	62, 65
TI4O5.....	Timer Input Capture 4/Output Compare 5	\$101E, \$101F	60
TIC1–TIC3.....	Timer Input Capture	\$1010–\$1015	60
TMSK1	Timer Interrupt Mask 1	\$1022	61
TMSK2.....	Timer Interrupt Mask 2	\$1024	62, 64
TOC1–TOC4.....	Timer Output Compare	\$1016–\$101D	60

1.3 Block Diagrams

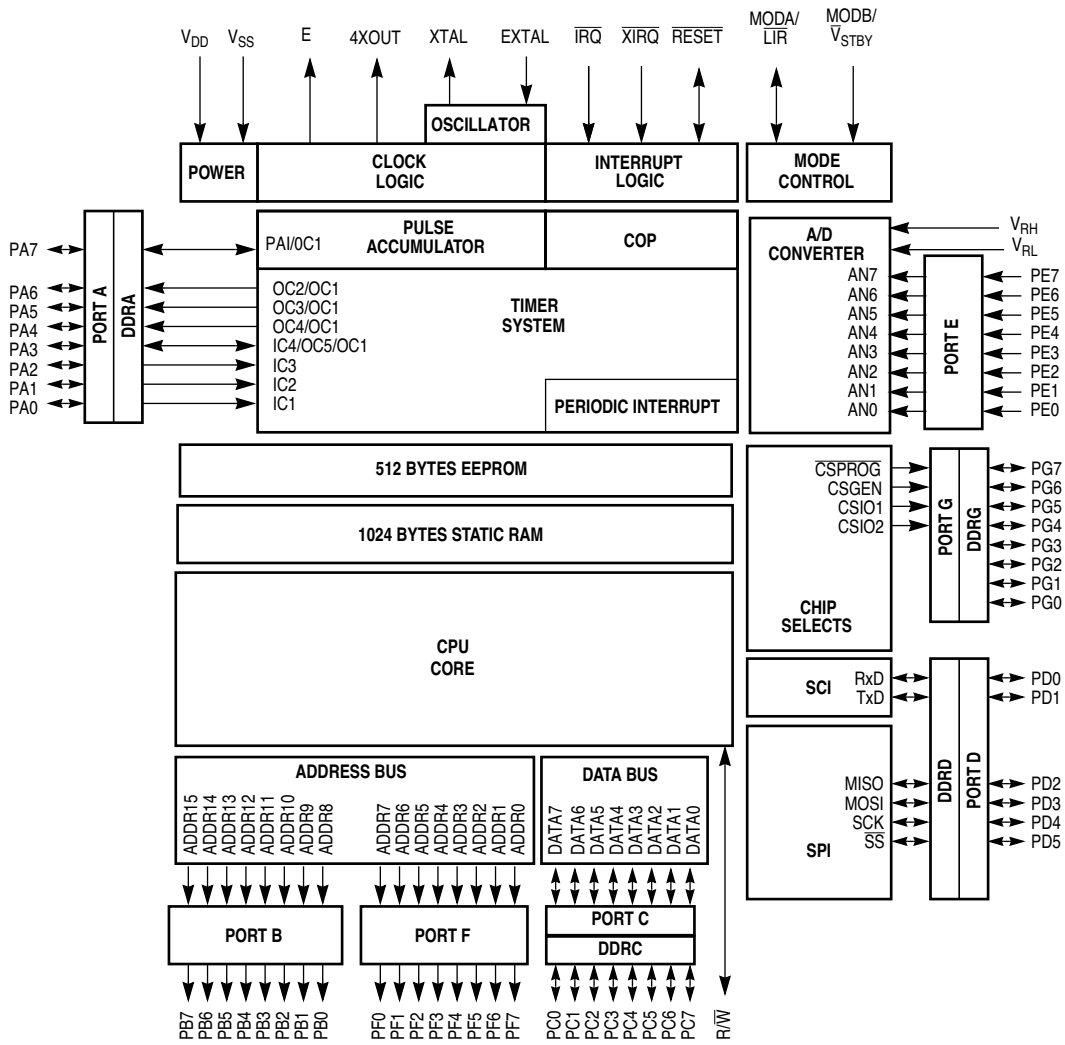

Figure 1 MC68HC11F1 Block Diagram

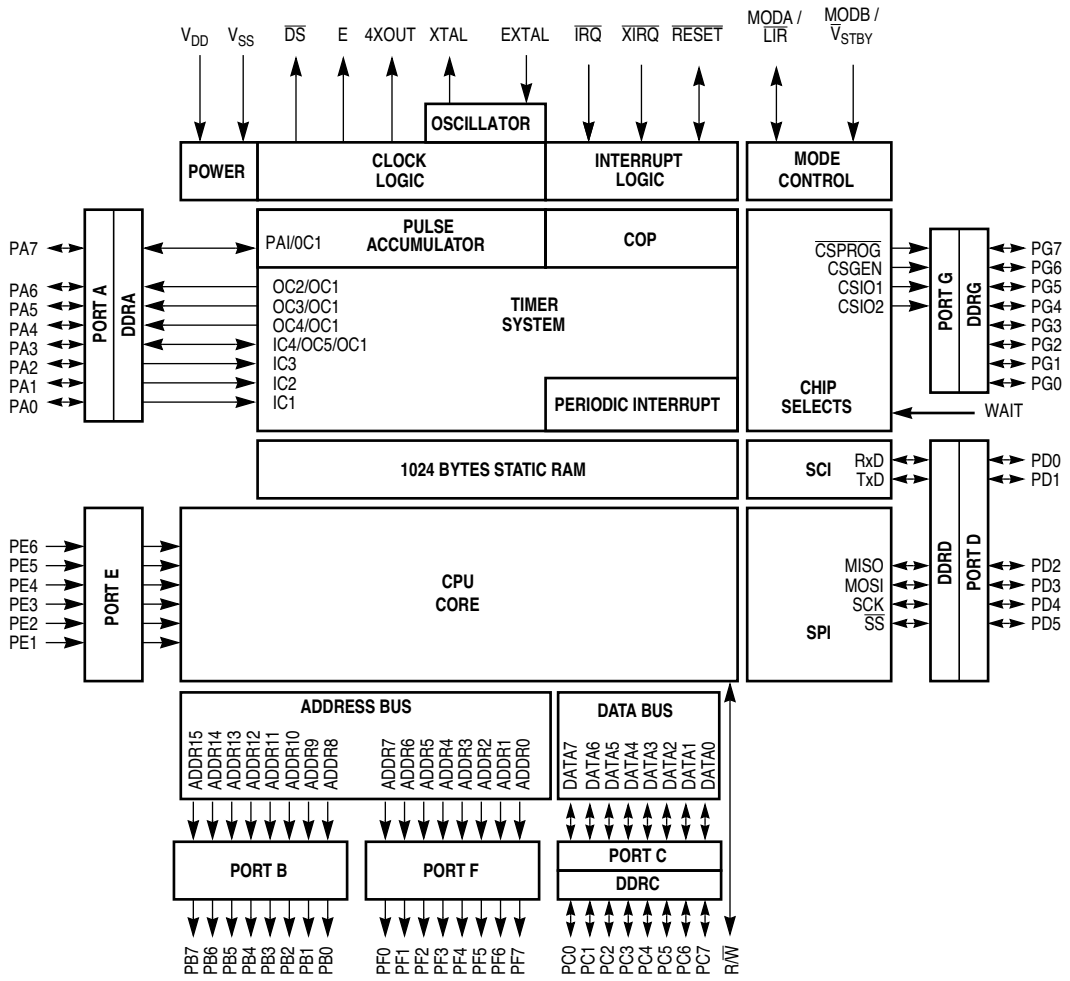

Figure 2 MC68HC11FC0 Block Diagram

2 Pin Assignments and Signal Descriptions

2.1 MC68HC11F1 Pin Assignments

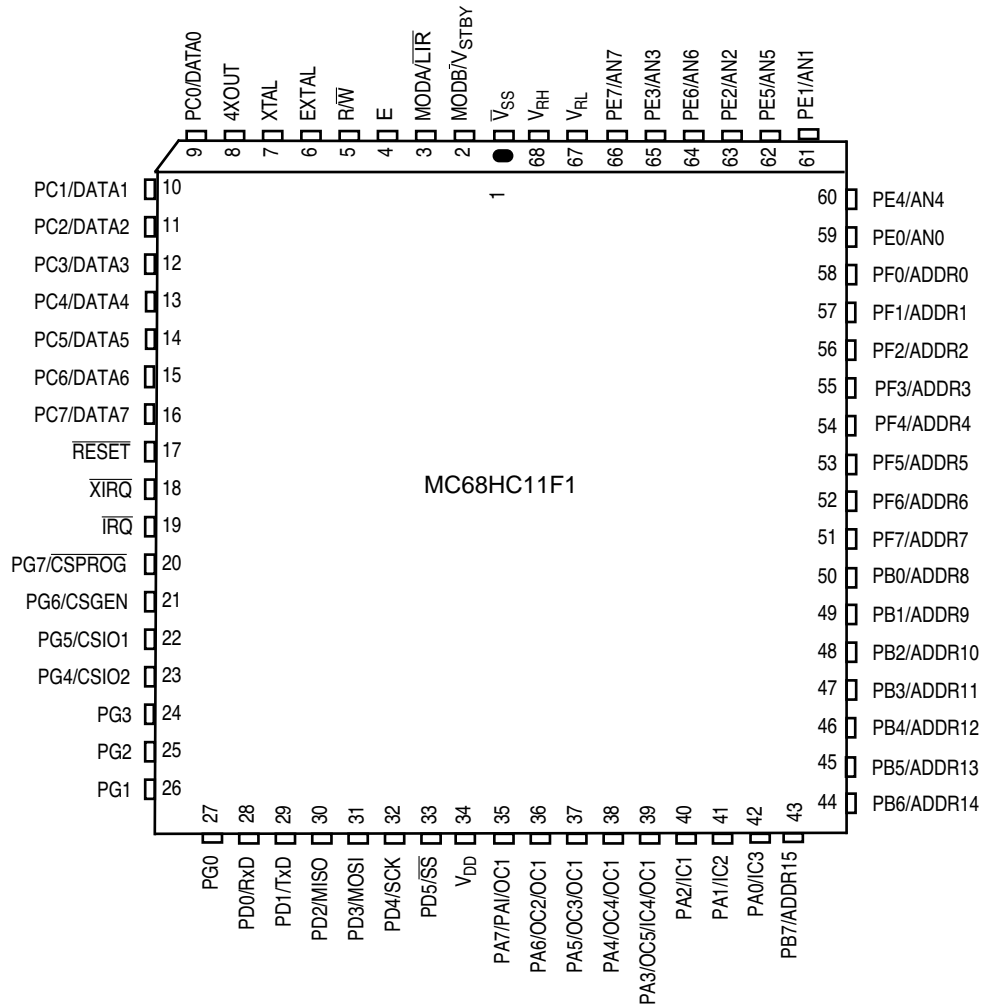

Figure 3 MC68HC11F1 68-Pin PLCC Pin Assignments

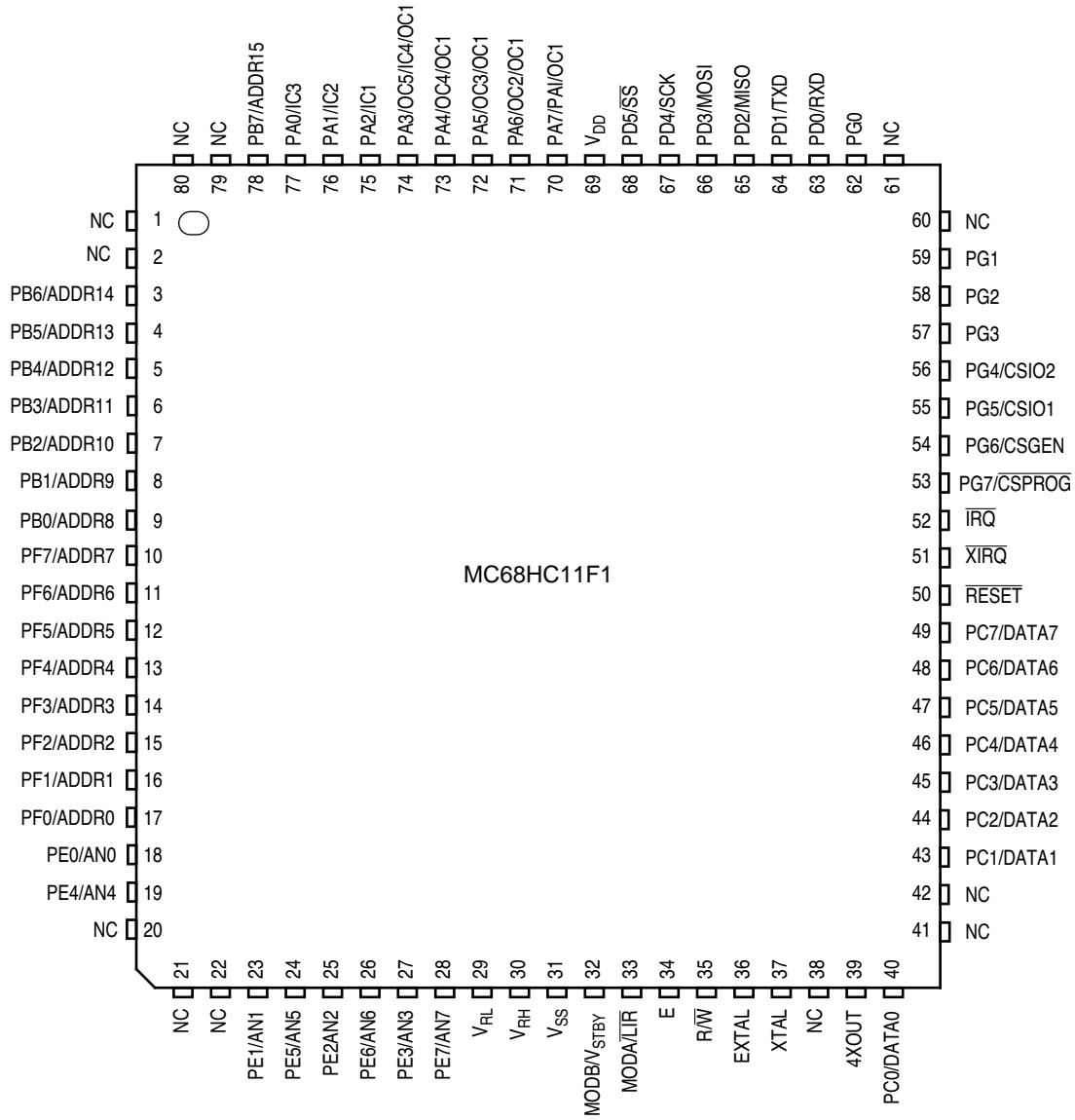

Figure 4 Pin Assignments for the MC68HC11F1 80-Pin QFP

2.2 MC68HC11FC0 Pin Assignments

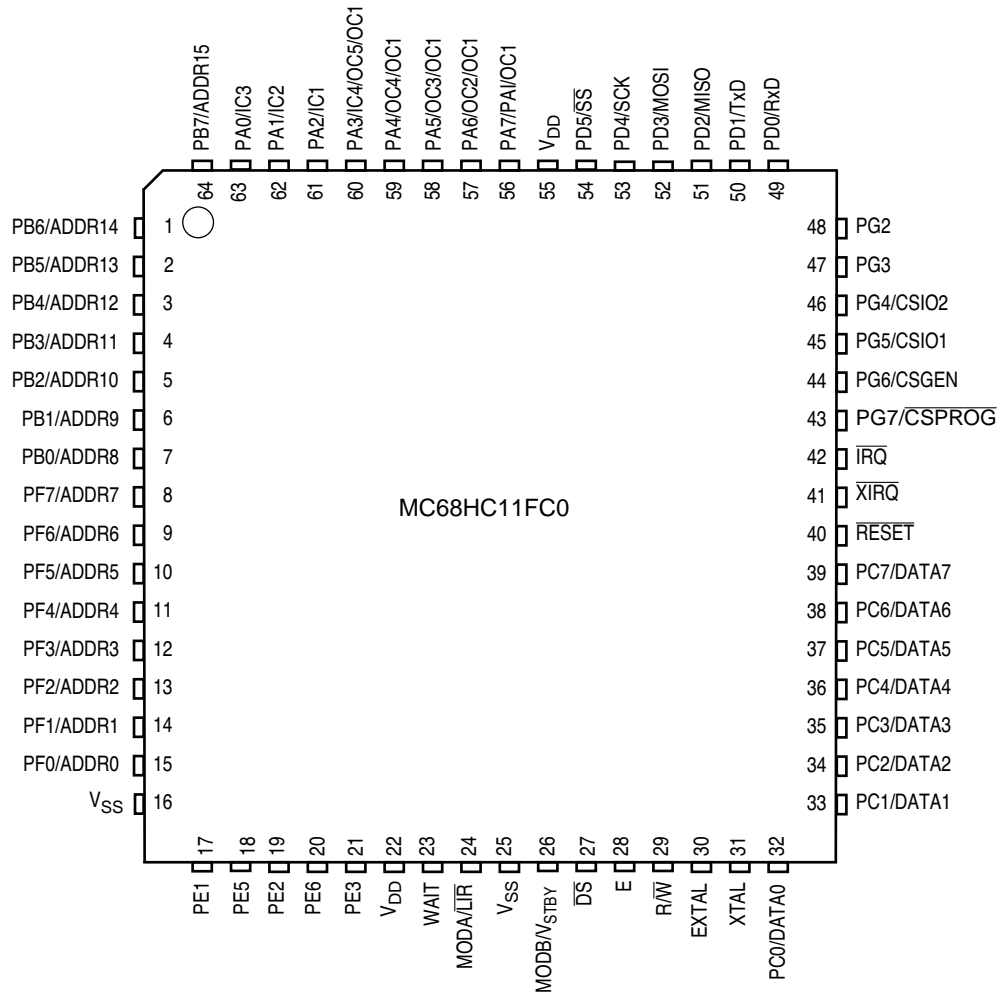

Figure 5 MC68HC11FC0 64-Pin QFP Pin Assignments

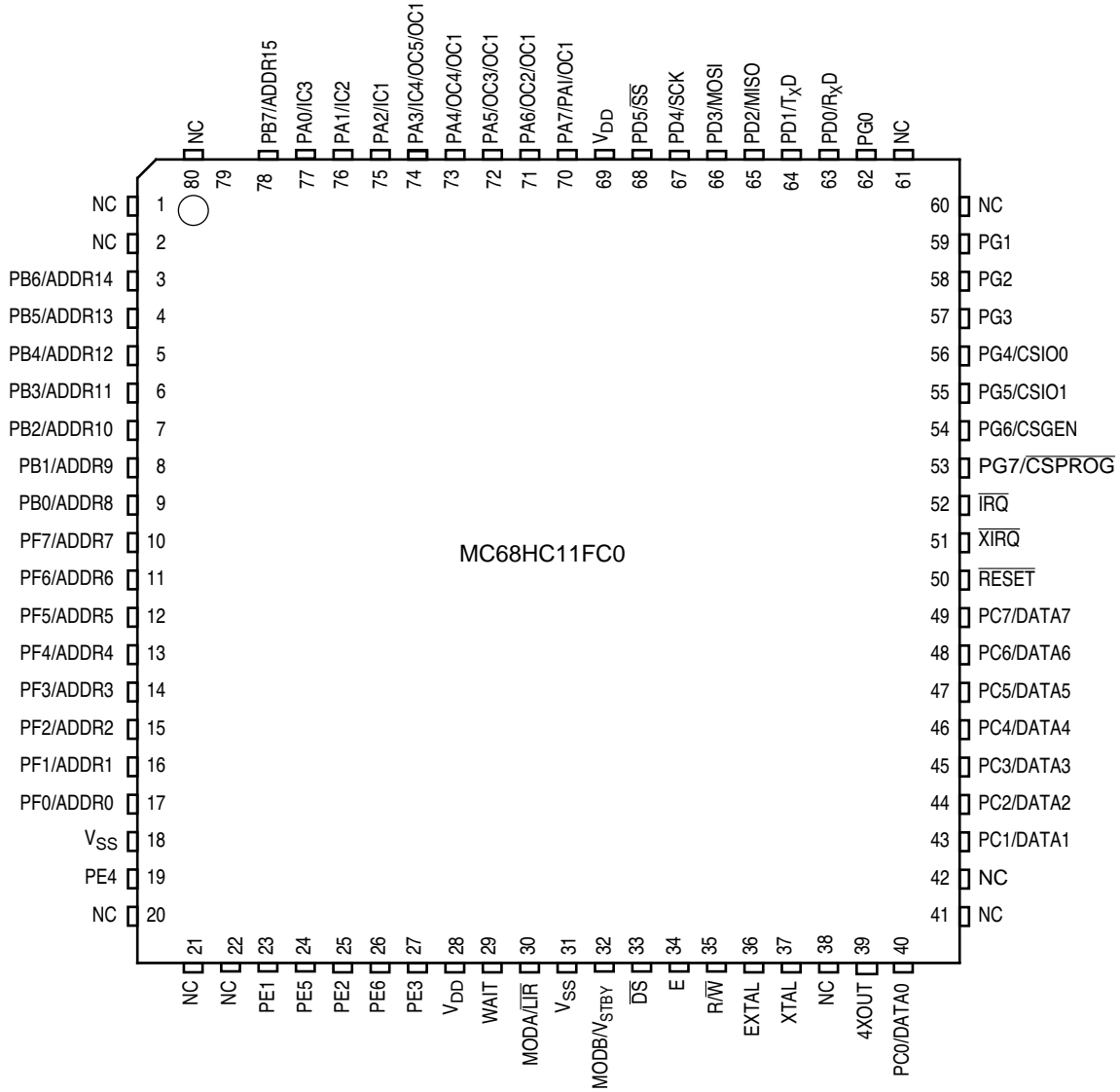

Figure 6 MC68HC11FC0 80-Pin TQFP Pin Assignments

2.3 Pin Descriptions

V_{DD} and V_{SS}

V_{DD} is the positive power input to the MCU, and V_{SS} is ground.

\overline{RESET}

This active-low input initializes the MCU to a known startup state. It also acts as an open-drain output to indicate that an internal failure has been detected in either the clock monitor or the COP watchdog circuits.

XTAL and EXTAL

These two pins provide the interface for either a crystal or a CMOS-compatible clock to drive the internal clock circuitry. The frequency applied to these pins is four times the desired bus frequency (E clock).

E

This pin provides an output for the E clock, the basic timing reference signal for the bus circuitry. The address bus is active when E is low, and the data bus is active when E is high.

\overline{DS}

The data strobe output is the inverted E clock. **\overline{DS} is present on the MC68HC11FC0 only.**

WAIT

This input is used to stretch the bus cycle to accommodate slower devices. The MCU samples the logic level at this pin on the rising edge of E clock. If it is high, the MCU holds the E clock high for the next four EXTAL clock cycles. If it is low, the E clock responds normally, going low two EXTAL cycles later. **The WAIT pin is present on the MC68HC11FC0 only.**

4XOUT

This pin provides a buffered oscillator signal to drive another M68HC11 MCU. **The 4XOUT pin is not present on the 64-pin QFP MC68HC11FC0 package.**

\overline{IRQ}

This active-low input provides a means of generating asynchronous, maskable interrupt requests for the CPU.

\overline{XIRQ}

This interrupt request input can be made non-maskable by clearing the X bit in the MCU's condition code register.

MODA/ \overline{LIR} and MODB/ \overline{VSTBY}

The logic level applied to the MODA and MODB pins at reset determines the MCU's operating mode (see **Table 7 in 4 Operating Modes and System Initialization**). After reset, MODA functions as \overline{LIR} , an open-drain output that indicates the start of an instruction cycle. MODB functions as V_{STBY} , providing a backup battery to maintain the contents of RAM when V_{DD} falls.

R/\overline{W}

In expanded and test modes, R/\overline{W} indicates the direction of transfers on the external data bus.

V_{RH} and V_{RL}

These pins provide the reference voltage for the analog-to-digital converter. Use bypass capacitors to minimize noise on these signals. Any noise on V_{RH} and V_{RL} will directly affect A/D accuracy. These pins are not present on the MC68HC11FC0.

Port Signals

On the MC68HC11F1, 54 pins are arranged into six 8-bit ports (ports A, B, C, E, F, and G) and one 6-bit port (port D). On the MC68HC11FC0, either 52 or 49 pins are available, depending on the package. General-purpose I/O port signals are discussed briefly in the following paragraphs. For additional information, refer to **7 Parallel Input/Output**.

Port A Pins

Port A is an 8-bit general-purpose I/O port (PA[7:0]) with a data register (PORTA) and a data direction register (DDRA). Port A pins share functions with the 16-bit timer system. Out of reset, PA[7:0] are general-purpose high-impedance inputs.

Port B Pins

Port B is an 8-bit output-only port. In single-chip modes, port B pins are general-purpose output pins (PB[7:0]). In expanded modes, port B pins act as the high-order address lines ADDR[15:8].

Port C Pins

Port C is an 8-bit general-purpose I/O port with a data register (PORTC) and a data direction register (DDRC). In single-chip modes, port C pins are general-purpose I/O pins PC[7:0]. In expanded modes, port C pins are configured as data bus pins DATA[7:0].

Port D Pins

Port D is a 6-bit general-purpose I/O port with a data register (PORTD) and a data direction register (DDRD). The six port D lines PD[5:0] can be used for general-purpose I/O or for the serial communications interface (SCI) or serial peripheral interface (SPI) subsystems.

Port E Pins

Port E is an 8-bit input-only port that is also used as the analog input port for the analog-to-digital converter. Port E pins that are not used for the A/D system can be used as general-purpose inputs. However, PORTE should not be read during the sample portion of an A/D conversion sequence.

NOTE

The A/D system is not available on the MC68HC11FC0. PE7 and PE0 are not available on the 80-pin MC68HC11FC0. PE7, PE4, and PE0 are not available on the 64-pin MC68HC11FC0.

Port F Pins

Port F is an 8-bit output-only port. In single-chip mode, port F pins are general-purpose output pins PF[7:0]. In expanded mode, port F pins act as the low-order address outputs ADDR[7:0].

Port G Pins

Port G is an 8-bit general-purpose I/O port. When enabled, four chip select signals are alternate functions of PG[7:4].

NOTE

PG[1:0] are not available on the 64-pin MC68HC11FC0.

3 Control Registers

The MC68HC11F1 and MC68HC11FC0 control registers determine most of the system's operating characteristics. They occupy a 96-byte relocatable memory block. Their names and bit mnemonics are summarized in the following table. Addresses shown are the default locations out of reset.

3.1 MC68HC11F1 Control Registers

Table 5 MC68HC11F1 Register and Control Bit Assignments

	Bit 7	6	5	4	3	2	1	Bit 0	
\$1000	PA7	PA6	PA5	PA4	PA3	PA2	PA1	PA0	PORTA
\$1001	DDA7	DDA6	DDA5	DDA4	DDA3	DDA2	DDA1	DDA0	DDRA
\$1002	PG7	PG6	PG5	PG4	PG3	PG2	PG1	PG0	PORTG
\$1003	DDG7	DDG6	DDG5	DDG4	DDG3	DDG2	DDG1	DDG0	DDRG
\$1004	PB7	PB6	PB5	PB4	PB3	PB2	PB1	PB0	PORTB
\$1005	PF7	PF6	PF5	PF4	PF3	PF2	PF1	PF0	PORTF
\$1006	PC7	PC6	PC5	PC4	PC3	PC2	PC1	PC0	PORTC
\$1007	DDC7	DDC6	DDC5	DDC4	DDC3	DDC2	DDC1	DDC0	DDRC
\$1008	0	0	PD5	PD4	PD3	PD2	PD1	PD0	PORTD
\$1009	0	0	DDD5	DDD4	DDD3	DDD2	DDD1	DDD0	DDRD
\$100A	PE7	PE6	PE5	PE4	PE3	PE2	PE1	PE0	PORTE
\$100B	FOC1	FOC2	FOC3	FOC4	FOC5	0	0	0	CFORC
\$100C	OC1M7	OC1M6	OC1M5	OC1M4	OC1M3	0	0	0	OC1M
\$100D	OC1D7	OC1D6	OC1D5	OC1D4	OC1D3	0	0	0	OC1D
\$100E	Bit 15	14	13	12	11	10	9	Bit 8	TCNT (High)
\$100F	Bit 7	6	5	4	3	2	1	Bit 0	TCNT (Low)
\$1010	Bit 15	14	13	12	11	10	9	Bit 8	TIC1 (High)
\$1011	Bit 7	6	5	4	3	2	1	Bit 0	TIC1 (Low)
\$1012	Bit 15	14	13	12	11	10	9	Bit 8	TIC2 (High)
\$1013	Bit 7	6	5	4	3	2	1	Bit 0	TIC2 (Low)
\$1014	Bit 15	14	13	12	11	10	9	Bit 8	TIC3 (High)
\$1015	Bit 7	6	5	4	3	2	1	Bit 0	TIC3 (Low)
\$1016	Bit 15	14	13	12	11	10	9	Bit 8	TOC1 (High)
\$1017	Bit 7	6	5	4	3	2	1	Bit 0	TOC1 (Low)
\$1018	Bit 15	14	13	12	11	10	9	Bit 8	TOC2 (High)
\$1019	Bit 7	6	5	4	3	2	1	Bit 0	TOC2 (Low)
\$101A	Bit 15	14	13	12	11	10	9	Bit 8	TOC3 (High)
\$101B	Bit 7	6	5	4	3	2	1	Bit 0	TOC3 (Low)
\$101C	Bit 15	14	13	12	11	10	9	Bit 8	TOC4 (High)
\$101D	Bit 7	6	5	4	3	2	1	Bit 0	TOC4 (Low)
\$101E	Bit 15	14	13	12	11	10	9	Bit 8	TI4/O5 (High)
\$101F	Bit 7	6	5	4	3	2	1	Bit 0	TI4/O5 (Low)
\$1020	OM2	OL2	OM3	OL3	OM4	OL4	OM5	OL5	TCTL1
\$1021	EDG4B	EDG4A	EDG1B	EDG1A	EDG2B	EDG2A	EDG3B	EDG3A	TCTL2

Freescale Semiconductor, Inc.

Table 5 MC68HC11F1 Register and Control Bit Assignments (Continued)

	Bit 7	6	5	4	3	2	1	Bit 0	
\$1022	OC1I	OC2I	OC3I	OC4I	I4/O5I	IC1I	IC2I	IC3I	TMSK1
\$1023	OC1F	OC2F	OC3F	OC4F	I4/O5F	IC1F	IC2F	IC3F	TFLG1
\$1024	TOI	RTII	PAOVI	PAII	0	0	PR1	PR0	TMSK2
\$1025	TOF	RTIF	PAOVF	PAIF	0	0	0	0	TFLG2
\$1026	0	PAEN	PAMOD	PEDGE	0	I4/O5	RTR1	RTR0	PACTL
\$1027	Bit 7	6	5	4	3	2	1	Bit 0	PACNT
\$1028	SPIE	SPE	DWOM	MSTR	CPOL	CPHA	SPR1	SPR0	SPCR
\$1029	SPIF	WCOL	0	MODF	0	0	0	0	SPSR
\$102A	Bit 7	6	5	4	3	2	1	Bit 0	SPDR
\$102B	TCLR	SCP2	SCP1	SCP0	RCKB	SCR2	SCR1	SCR0	BAUD
\$102C	R8	T8	0	M	WAKE	0	0	0	SCCR1
\$102D	TIE	TCIE	RIE	ILIE	TE	RE	RWU	SBK	SCCR2
\$102E	TDRE	TC	RDRF	IDLE	OR	NF	FE	0	SCSR
\$102F	Bit 7	6	5	4	3	2	1	Bit 0	SCDR
\$1030	CCF	0	SCAN	MULT	CD	CC	CB	CA	ADCTL
\$1031	Bit 7	6	5	4	3	2	1	Bit 0	ADR1
\$1032	Bit 7	6	5	4	3	2	1	Bit 0	ADR2
\$1033	Bit 7	6	5	4	3	2	1	Bit 0	ADR3
\$1034	Bit 7	6	5	4	3	2	1	Bit 0	ADR4
\$1035	0	0	0	PTCON	BPRT3	BPRT2	BPRT1	BPRT0	BPROT
\$1036									Reserved
\$1037									Reserved
\$1038	GWOM	CWOM	CLK4X	LIRDV	0	SPRBYP	0	0	OPT2
\$1039	0	0	IRQE	DLY	CME	FCME	CR1	CR0	OPTION
\$103A	Bit 7	6	5	4	3	2	1	Bit 0	COPRST
\$103B	ODD	EVEN	0	BYTE	ROW	ERASE	EELAT	EEPGM	PPROG
\$103C	RBOOT	SMOD	MDA	IRV	PSEL3	PSEL2	PSEL1	PSEL0	HPRIO
\$103D	RAM3	RAM2	RAM1	RAM0	REG3	REG2	REG1	REG0	INIT
\$103E	TILOP	0	OCCR	CBYP	DISR	FCM	FCOP	0	TEST1
\$103F	EE3	EE2	EE1	EE0	1	NOCOP	1	EEON	CONFIG
\$1040									Reserved
to									
\$105B									Reserved
\$105C	I01SA	I01SB	I02SA	I02SB	GSTHA	GSTGB	PSTHA	PSTHB	CSSTRH
\$105D	I01EN	I01PL	I02EN	I02PL	GCSPR	PCSEN	PSIZA	PSIZB	CSCTL
\$105E	GA15	GA14	GA13	GA12	GA11	GA10	0	0	CSGADR
\$105F	I01AV	I02AV	0	GNPOL	GAVLD	GSIZA	GSIZB	GSIZC	CSGSIZ

3.2 MC68HC11FC0 Control Registers

Table 6 MC68HC11FC0 Register and Control Bit Assignments

	Bit 7	6	5	4	3	2	1	Bit 0	
\$1000	PA7	PA6	PA5	PA4	PA3	PA2	PA1	PA0	PORTA
\$1001	DDA7	DDA6	DDA5	DDA4	DDA3	DDA2	DDA1	DDA0	DDRA
\$1002	PG7	PG6	PG5	PG4	PG3	PG2	PG1	PG0	PORTG
\$1003	DDG7	DDG6	DDG5	DDG4	DDG3	DDG2	DDG1	DDG0	DDRG
\$1004	PB7	PB6	PB5	PB4	PB3	PB2	PB1	PB0	PORTB
\$1005	PF7	PF6	PF5	PF4	PF3	PF2	PF1	PF0	PORTF
\$1006	PC7	PC6	PC5	PC4	PC3	PC2	PC1	PC0	PORTC
\$1007	DDC7	DDC6	DDC5	DDC4	DDC3	DDC2	DDC1	DDC0	DDRC
\$1008	0	0	PD5	PD4	PD3	PD2	PD1	PD0	PORTD
\$1009	0	0	DDD5	DDD4	DDD3	DDD2	DDD1	DDD0	DDRD
\$100A	PE7	PE6	PE5	PE4	PE3	PE2	PE1	PE0	PORTE
\$100B	FOC1	FOC2	FOC3	FOC4	FOC5	0	0	0	CFORC
\$100C	OC1M7	OC1M6	OC1M5	OC1M4	OC1M3	0	0	0	OC1M
\$100D	OC1D7	OC1D6	OC1D5	OC1D4	OC1D3	0	0	0	OC1D
\$100E	Bit 15	14	13	12	11	10	9	Bit 8	TCNT (High)
\$100F	Bit 7	6	5	4	3	2	1	Bit 0	TCNT (Low)
\$1010	Bit 15	14	13	12	11	10	9	Bit 8	TIC1 (High)
\$1011	Bit 7	6	5	4	3	2	1	Bit 0	TIC1 (Low)
\$1012	Bit 15	14	13	12	11	10	9	Bit 8	TIC2 (High)
\$1013	Bit 7	6	5	4	3	2	1	Bit 0	TIC2 (Low)
\$1014	Bit 15	14	13	12	11	10	9	Bit 8	TIC3 (High)
\$1015	Bit 7	6	5	4	3	2	1	Bit 0	TIC3 (Low)
\$1016	Bit 15	14	13	12	11	10	9	Bit 8	TOC1 (High)
\$1017	Bit 7	6	5	4	3	2	1	Bit 0	TOC1 (Low)
\$1018	Bit 15	14	13	12	11	10	9	Bit 8	TOC2 (High)
\$1019	Bit 7	6	5	4	3	2	1	Bit 0	TOC2 (Low)
\$101A	Bit 15	14	13	12	11	10	9	Bit 8	TOC3 (High)
\$101B	Bit 7	6	5	4	3	2	1	Bit 0	TOC3 (Low)
\$101C	Bit 15	14	13	12	11	10	9	Bit 8	TOC4 (High)
\$101D	Bit 7	6	5	4	3	2	1	Bit 0	TOC4 (Low)
\$101E	Bit 15	14	13	12	11	10	9	Bit 8	TI4/O5 (High)
\$101F	Bit 7	6	5	4	3	2	1	Bit 0	TI4/O5 (Low)
\$1020	OM2	OL2	OM3	OL3	OM4	OL4	OM5	OL5	TCTL1
\$1021	EDG4B	EDG4A	EDG1B	EDG1A	EDG2B	EDG2A	EDG3B	EDG3A	TCTL2
\$1022	OC1I	OC2I	OC3I	OC4I	I4/O5I	IC1I	IC2I	IC3I	TMSK1
\$1023	OC1F	OC2F	OC3F	OC4F	I4/O5F	IC1F	IC2F	IC3F	TFLG1
\$1024	TOI	RTII	PAOVI	PAII	0	0	PR1	PR0	TMSK2
\$1025	TOF	RTIF	PAOVF	PAIF	0	0	0	0	TFLG2

Freescale Semiconductor, Inc.

Table 6 MC68HC11FC0 Register and Control Bit Assignments (Continued)

	Bit 7	6	5	4	3	2	1	Bit 0	
\$1026	0	PAEN	PAMOD	PEDGE	0	I4/05	RTR1	RTR0	PACTL
\$1027	Bit 7	6	5	4	3	2	1	Bit 0	PACNT
\$1028	SPIE	SPE	DWOM	MSTR	CPOL	CPHA	SPR1	SPR0	SPCR
\$1029	SPIF	WCOL	0	MODF	0	0	0	0	SPSR
\$102A	Bit 7	6	5	4	3	2	1	Bit 0	SPDR
\$102B	TCLR	SCP2	SCP1	SCP0	RCKB	SCR2	SCR1	SCR0	BAUD
\$102C	R8	T8	0	M	WAKE	0	0	0	SCCR1
\$102D	TIE	TCIE	RIE	ILIE	TE	RE	RWU	SBK	SCCR2
\$102E	TDRE	TC	RDRF	IDLE	OR	NF	FE	0	SCSR
\$102F	Bit 7	6	5	4	3	2	1	Bit 0	SCDR
\$1030									Reserved
to									
\$1037									Reserved
\$1038	GWOM	CWOM	CLK4X	LIRDV	0	SPRBYP	0	0	OPT2
\$1039	0	0	IRQE	DLY	CME	FCME	CR1	CR0	OPTION
\$103A	Bit 7	6	5	4	3	2	1	Bit 0	COPRST
\$103B									Reserved
\$103C	RBOOT	SMOD	MDA	IRV	PSEL3	PSEL2	PSEL1	PSEL0	HPRIO
\$103D	RAM5	RAM4	RAM3	RAM2	RAM1	RAM0	REG1	REG0	INIT
\$103E	TILOP	0	OCCR	CBYP	DISR	FCM	FCOP	0	TEST1
\$103F	0	0	0	0	0	NOCOP	0	0	CONFIG
\$1040									Reserved
to									
\$105B									Reserved
\$105C	I01SA	I01SB	I02SA	I02SB	GSTHA	GSTGB	PSTHA	PSTHB	CSSTRH
\$105D	I01EN	I01PL	I02EN	I02PL	GCSPR	PCSEN	PSIZA	PSIZB	CSCTL
\$105E	GA15	GA14	GA13	GA12	GA11	GA10	0	0	CSGADR
\$105F	I01AV	I02AV	0	GNPOL	GAVLD	GSIZA	GSIZB	GSIZC	CSGSIZ

4 Operating Modes and System Initialization

The 16-bit address bus can access 64 Kbytes of memory. Because the MC68HC11F1 and MC68HC11FC0 are intended to operate principally in expanded mode, there is no internal ROM and the address bus is non-multiplexed. Both devices include 1 Kbyte of static RAM, a 96-byte control register block, and 256 bytes of bootstrap ROM. The MC68HC11F1 also includes 512 bytes of EEPROM.

RAM and registers can be remapped on both the MC68HC11F1 and the MC68HC11FC0. On both the MC68HC11F1 and the MC68HC11FC0, out of reset RAM resides at \$0000 to \$03FF and registers reside at \$1000 to \$105F. On the MC68HC11F1, RAM and registers can both be remapped to any 4-Kbyte boundary. On the MC68HC11FC0, RAM can be remapped to any 1-Kbyte boundary, and registers can be remapped to any 4-Kbyte boundary in the first 16 Kbytes of address space.

RAM and control register locations are defined by the INIT register, which can be written only once within the first 64 E-clock cycles after a reset in normal modes. It becomes a read-only register thereafter. If RAM and the control register block are mapped to the same boundary, the register block has priority of the first 96 bytes.

In expanded and special test modes in the MC68HC11F1, EEPROM is located from \$xE00 to \$xFFF, where x represents the value of the four high-order bits of the CONFIG register. EEPROM is enabled by the EEON bit of the CONFIG register. In single-chip and bootstrap modes, the EEPROM is located from \$FE00 to \$FFFF.

4.1 Operating Modes

Bootstrap ROM resides at addresses \$BF00–\$BFFF, and is only available when the MCU operates in special bootstrap operating mode. Operating modes are determined by the logic levels applied to the MODB and MODA pins at reset.

In single-chip mode, the MCU functions as a self-contained microcontroller and has no external address or data bus. Ports B, C and F are available for general-purpose I/O (GPIO). Ports B and F are outputs only; each of the port C pins can be configured as input or output.

CAUTION

The MC68HC11FC0 must not be configured to boot in single-chip mode because it has no internal ROM or EEPROM. Operation of the device in single-chip mode will result in erratic behavior.

In expanded mode, the MCU can access external memory. Ports B and F provide the address bus, and port C is the data bus.

Special bootstrap mode is a variation of single chip mode that provides access to the internal bootstrap ROM. In this mode, the user can download a program into on-chip RAM through the serial communication interface (SCI).

Special test mode, a variation of expanded mode, is primarily used during Motorola's internal production testing, but can support emulation and debugging during program development.

Table 7 shows a summary of operating modes, mode select pins, and control bits in the HPRIO register.

Table 7 Hardware Mode Select Summary

Input Pins		Mode Description	Control Bits in HPRIO (Latched at Reset)		
MODB	MODA		RBOOT	SMOD	MDA
1	0	Single Chip	0	0	0
1	1	Expanded	0	0	1
0	0	Special Bootstrap	1	1	0
0	1	Special Test	0	1	1

4.2 Memory Maps

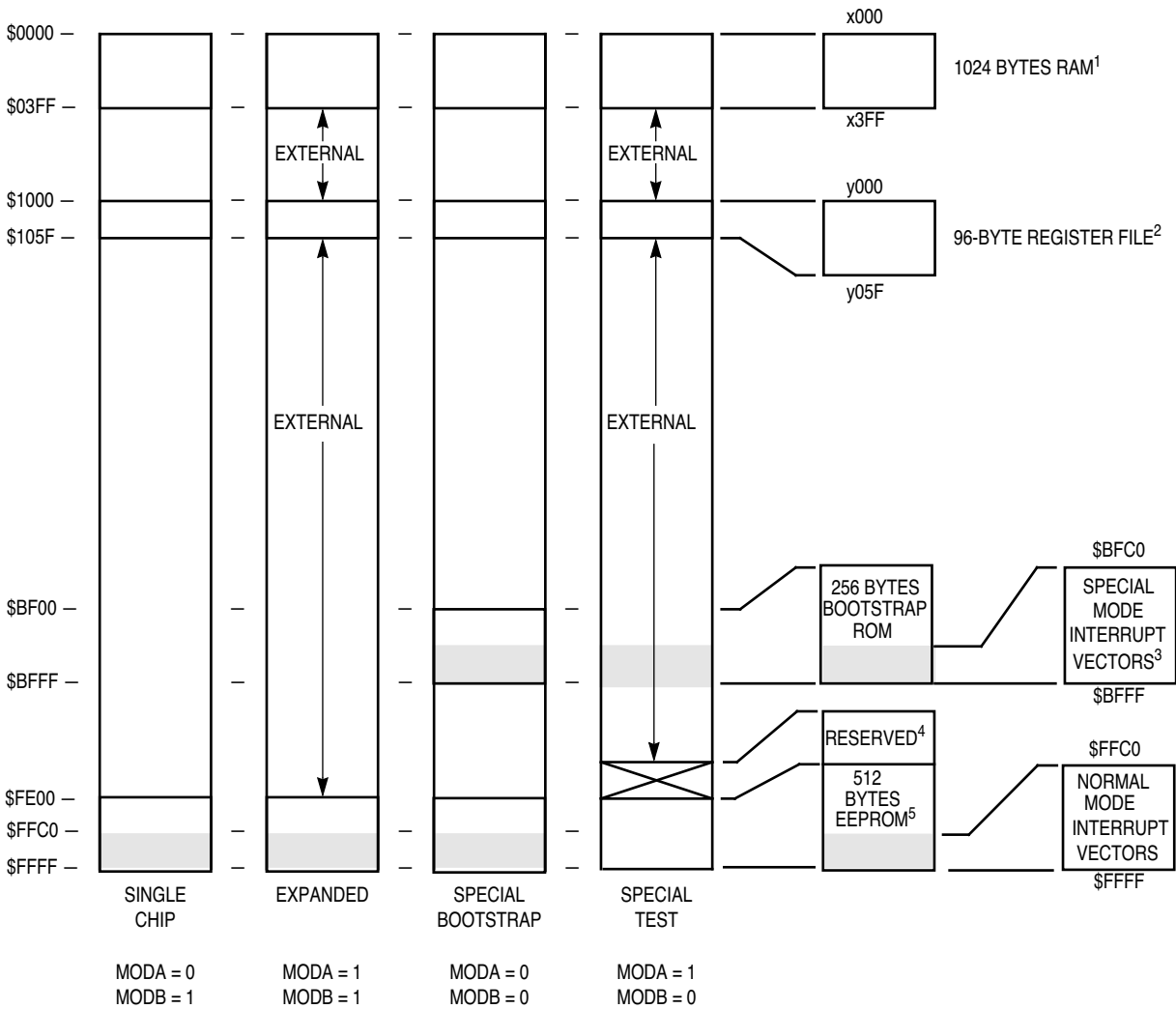

NOTES:

1. RAM can be remapped to any 4-Kbyte boundary (\$x000). "x" represents the value contained in RAM[3:0] in the INIT register.
2. The register block can be remapped to any 4-Kbyte boundary (\$y000). "y" represents the value contained in REG[3:0] in the INIT register.
3. Special test mode vectors are externally addressed.
4. In special test mode the address locations \$zD00—\$zDFF are not externally addressable. "z" represents the value of bits EE[3:0] in the CONFIG register.
5. EEPROM can be remapped to any 4-Kbyte boundary (\$z000). "z" represents the value contained in EE[3:0] in the CONFIG register.

Figure 7 MC68HC11F1 Memory Map

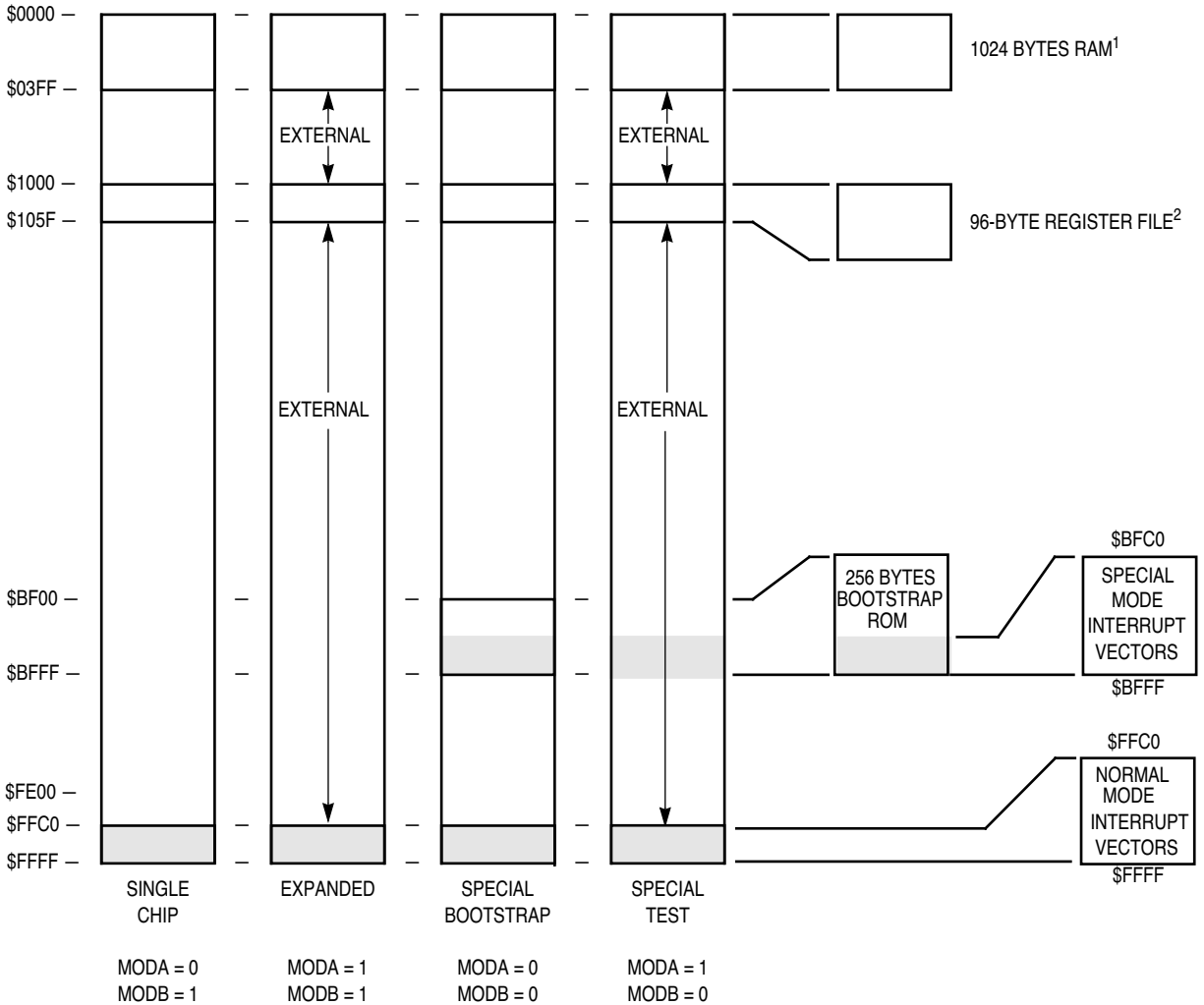

NOTES:

1. RAM can be remapped to any 1-Kbyte boundary, depending on the value contained in the RAM field in the INIT register.
2. The register block can be remapped to \$0000, \$2000, or \$3000, depending on the value contained in REG[1:0] in the INIT register.

Figure 8 MC68HC11FC0 Memory Map

4.3 System Initialization Registers

HPRIO — Highest Priority Interrupt and Miscellaneous

\$x03C

	Bit 7	6	5	4	3	2	1	Bit 0	
	RBOOT	SMOD	MDA	IRV	PSEL3	PSEL2	PSEL1	PSEL0	
RESET:	0	0	0	0	0	1	0	1	Single-Chip
	0	0	1	0	0	1	0	1	Expanded
	1	1	0	1	0	1	0	1	Bootstrap
	0	1	1	1	0	1	0	1	Special Test

RBOOT — Read Bootstrap ROM

RBOOT is valid only when SMOD is set to one (special bootstrap or special test mode). RBOOT can only be written in special modes but can be read anytime.

0 = Boot loader ROM disabled and not in memory map

1 = Boot loader ROM enabled and in memory map at \$BF00–\$BFFF

SMOD and MDA — Special Mode Select and Mode Select A

The initial value of SMOD is the *inverse* of the logic level present on the MODB pin at the rising edge of reset. The initial value of MDA *equals* the logic level present on the MODA pin at the rising edge of reset. These two bits can be read at any time. They can be written at any time in special modes. Neither bit can be written in normal modes. SMOD cannot be set once it has been cleared. Refer to **Table 8**.

Table 8 Hardware Mode Select Summary

Input Pins		Mode Description	Control Bits in HPRIO (Latched at Reset)		
MODB	MODA		RBOOT	SMOD	MDA
1	0	Single Chip	0	0	0
1	1	Expanded	0	0	1
0	0	Special Bootstrap	1	1	0
0	1	Special Test	0	1	1

IRV — Internal Read Visibility

This bit can be read at any time. It can be written at any time in special modes, but only once in normal modes. In single-chip and bootstrap modes, IRV has no meaning or effect.

0 = Internal reads not visible

1 = Data from internal reads is driven on the external data bus

PSEL[3:0] — See **5.2 Reset and Interrupt Registers**, page 27.

INIT — RAM and I/O Mapping (MC68HC11FC0 only)

\$x03D

	Bit 7	6	5	4	3	2	1	Bit 0
	RAM5	RAM4	RAM3	RAM2	RAM1	RAM0	REG1	REG0
RESET:	0	0	0	0	0	0	0	1

The INIT register can be written only once in first 64 cycles out of reset in normal modes, or at any time in special modes.

NOTE

The register diagram above applies to the MC68HC11FC0 only. A diagram and bit descriptions of the INIT register in the MC68HC11F1 are provided elsewhere in this section.

RAM[5:0] — Internal RAM Map Position

These bits determine the upper six bits of the RAM address and allow mapping of the RAM to any one-Kbyte boundary.

REG[1:0] — Register Block Map Position

These bits determine the location of the register block, as shown in **Table 9**.

Table 9 Register Block Location

REG[1:0]	Register Block Address
0 0	\$0000 – \$005F
0 1	\$1000 – \$105F
1 0	\$2000 – \$205F
1 1	\$3000 – \$305F

INIT — RAM and I/O Mapping (MC68HC11F1 only)

\$x03D

	Bit 7	6	5	4	3	2	1	Bit 0
	RAM3	RAM2	RAM1	RAM0	REG3	REG4	REG1	REG0
RESET:	0	0	0	0	0	0	0	1

The INIT register can be written only once in first 64 cycles out of reset in normal modes, or at any time in special modes.

NOTE

The register diagram above applies to the MC68HC11F1 only. A diagram and bit descriptions of the INIT register in the MC68HC11FC0 are provided elsewhere in this section.

RAM[3:0] — Internal RAM Map Position

These bits determine the upper four bits of the RAM address and allow mapping of the RAM to any four-Kbyte boundary. Refer to **Table 10**.

REG[3:0] — 96-Byte Register Block Map Position

These bits determine bits the upper 4 bits of the register block and allow mapping of the register block to any four-Kbyte boundary. Refer to **Table 10**.

Table 10 RAM and Register Mapping

RAM[3:0]	Location	REG[3:0]	Location
0000	\$0000-\$03FF	0000	\$0000-\$005F
0001	\$1000-\$13FF	0001	\$1000-\$105F
0010	\$2000-\$23FF	0010	\$2000-\$205F
0011	\$3000-\$33FF	0011	\$3000-\$305F
0100	\$4000-\$43FF	0100	\$4000-\$405F
0101	\$5000-\$53FF	0101	\$5000-\$505F
0110	\$6000-\$63FF	0110	\$6000-\$605F
0111	\$7000-\$73FF	0111	\$7000-\$705F
1000	\$8000-\$83FF	1000	\$8000-\$805F
1001	\$9000-\$93FF	1001	\$9000-\$905F
1010	\$A000-\$A3FF	1010	\$A000-\$A05F
1011	\$B000-\$B3FF	1011	\$B000-\$B05F
1100	\$C000-\$C3FF	1100	\$C000-\$C05F
1101	\$D000-\$D3FF	1101	\$D000-\$D05F
1110	\$E000-\$E3FF	1110	\$E000-\$E05F
1111	\$F000-\$F3FF	1111	\$F000-\$F05F

OPT2 — System Configuration Option Register 2

\$x038

	Bit 7	6	5	4	3	2	1	Bit 0
	GWOM	CWOM	CLK4X	LIRDV	—	SPRBYP	—	—
RESET	0	0	1	0	0	0	0	0

GWOM — Port G Wired-OR Mode Option

Refer to **7.8 Parallel I/O Registers**, page 36.

CWOM — Port C Wired-OR Mode Option
Refer to **7.8 Parallel I/O Registers**, page 37.

CLK4X — 4XCLK Output Enable
This bit can only be written once after reset in all modes.
0 = 4XOUT clock output is disabled
1 = Buffered oscillator is driven on the 4XOUT clock output

LIRDV — Load Instruction Register Driven
In order to detect consecutive instructions in a high-speed application, $\overline{\text{LIR}}$ can be driven high for one quarter of an E-clock cycle during each instruction fetch.
0 = $\overline{\text{LIR}}$ signal is not driven high.
1 = $\overline{\text{LIR}}$ signal is driven high.

Bits 3, 1, 0 — Not implemented. Reads always return zero and writes have no effect.

SPRBYP — See **10.2 SPI Registers**, page 52.

OPTION — System Configuration Options **\$x039**

	Bit 7	6	5	4	3	2	1	Bit 0
	ADPU	CSEL	IRQE*	DLY*	CME	FCME*	CR1*	CR0*
RESET:	0	0	0	1	0	0	0	0

*Can be written only once in first 64 cycles out of reset in normal modes, or at any time in special modes.

ADPU — A/D Power-Up
This bit is implemented on the MC68HC11F1 only. On the MC68HC11FC0, reads always return zero and writes have no effect.
0 = A/D system disabled
1 = A/D system enabled

CSEL — Clock Select
This bit is implemented on the MC68HC11F1 only. On the MC68HC11FC0, reads always return zero and writes have no effect.
0 = A/D and EEPROM use system E clock
1 = A/D and EEPROM use internal RC clock

IRQE — $\overline{\text{IRQ}}$ Select Edge Sensitive Only
0 = Low level recognition
1 = Falling edge recognition

DLY — Enable Oscillator Start-Up Delay on Exit from STOP
0 = No stabilization delay on exit from STOP
1 = Stabilization delay of 4064 E-clock cycles is enabled on exit from STOP

CME — Clock Monitor Enable
0 = Clock monitor disabled; slow clocks can be used
1 = Slow or stopped clocks cause clock failure reset

FCME — Force Clock Monitor Enable
0 = Clock monitor circuit follows the state of the CME bit
1 = Clock monitor circuit is enabled until the next reset

In order to use both STOP and the clock monitor, the CME bit should be written to zero prior to executing a STOP instruction and rewritten to one after recovery from STOP. FCME should be kept cleared if the user intends to use the STOP instruction.

CR[1:0] — COP Timer Rate Select
Refer to **5.2 Reset and Interrupt Registers**, page 27.

CONFIG — EEPROM Mapping, COP, EEPROM Enables

\$x03F

	Bit 7	6	5	4	3	2	1	Bit 0
	EE3	EE2	EE1	EE0	1	NOCOP	1	EEON
RESET	U	U	U	U	1	U	1	U

U = Unaffected by reset

Bits 7:3 — See **6.2 EEPROM Registers**, page 30. (These bits are implemented on the MC68HC11F1 only.)

NOCOP — COP System Disable

- 0 = COP enabled (forces reset on time-out)
- 1 = COP disabled (does not force reset on time-out)

TEST1 — Factory Test

\$x03E

	Bit 7	6	5	4	3	2	1	Bit 0
	TILOP	0	OCCR	CBYP	DISR	FCM	FCOP	0
RESET:	0	0	0	0	—	0	0	0

These bits can only be written in test and bootstrap modes.

TILOP — Test Illegal Opcode

This test mode allows serial testing of all illegal opcodes without servicing an interrupt after each illegal opcode is fetched.

- 0 = Normal operation (trap on illegal opcodes)
- 1 = Inhibit LIR when an illegal opcode is found

Bit 6 — Not implemented. Reads always return zero and writes have no effect.

OCCR — Output Condition Code Register to Timer Port

- 0 = Normal operation
- 1 = Condition code bits H, N, Z, V and C are driven on PA[7:3] to allow a test system to monitor CPU operation

CBYP — Timer Divider Chain Bypass

- 0 = Normal operation
- 1 = The 16-bit free-running timer is divided into two 8-bit halves and the prescaler is bypassed. The system E clock drives both halves directly.

DISR — Disable Resets from COP and Clock Monitor

In test and bootstrap modes, this bit is reset to one to inhibit clock monitor and COP resets. In normal modes, DISR is reset to zero.

- 0 = Normal operation
- 1 = COP and Clock Monitor failure do not generate a system reset

FCM — Force Clock Monitor Failure

- 0 = Normal operation
- 1 = Generate an immediate clock monitor failure reset. Note that the CME bit in the OPTION register must also be set in order to force the reset.

FCOP — Force COP Watchdog Failure

- 0 = Normal operation
- 1 = Generate an immediate COP failure reset. Note that the NOCOP bit in the CONFIG register must be cleared (COP enabled) in order to force the reset.

Bit 0 — Not implemented. Reads always return zero and writes have no effect.

5 Resets and Interrupts

There are three sources of reset on the MC68HC11F1 and MC68HC11FC0, each having its own reset vector:

- $\overline{\text{RESET}}$ pin
- Clock monitor failure
- Computer operating properly (COP) failure

There are 22 interrupt sources serviced by 18 interrupt vectors. (The SCI interrupt vector services five SCI interrupt sources.) Three of the interrupt vectors are non-maskable:

- Illegal opcode trap
- Software interrupt
- $\overline{\text{XIRQ}}$ pin (pseudo non-maskable interrupt)

The other 19 interrupts, generated mostly by on-chip peripheral systems, are maskable. Maskable interrupts are recognized only if the global interrupt mask bit (I) in the condition code register (CCR) is clear. Maskable interrupts have a default priority arrangement out of reset. However, any one interrupt source can be elevated to the highest maskable priority position by writing to the HPRIO register. This register can be written at any time, provided the I bit in the CCR is set.

In addition to the global I bit, all maskable interrupt sources except the external interrupt ($\overline{\text{IRQ}}$ pin) are subject to local enable bits in control registers. Each of these interrupt sources also sets a corresponding flag bit in a control register that can be polled by software.

Several of these flags are automatically cleared during the normal course of responding to the interrupt requests. For example, the RDRF flag is set when a byte has been received in the SCI. The normal response to an RDRF interrupt request is to read the SCI status register to check for receive errors, then to read the received data from the SCI data register. It is precisely these two steps that are required to clear the RDRF flag, so no further instructions are necessary.

5.1 Interrupt Sources

The following table summarizes the interrupt sources, vector addresses, masks, and flag bits.

Table 11 Interrupt and Reset Vector Assignments

Vector Address	Interrupt Source	CCR Mask	Local Mask	Flag Bit
FFC0, C1 to FFD4, D5	Reserved	—	—	—
FFD6, D7	SCI Serial System	I Bit		
	SCI Transmit Complete		TCIE	TC
	SCI Transmit Data Register Empty		TIE	TDRE
	SCI Idle Line Detect		ILIE	IDLE
	SCI Receiver Overrun		RIE	OR
	SCI Receive Data Register Full		RIE	RDRF
FFD8, D9	SPI Serial Transfer Complete	I Bit	SPIE	SPIF
FFDA, DB	Pulse Accumulator Input Edge	I Bit	PAII	PAIF
FFDC, DD	Pulse Accumulator Overflow	I Bit	PAOVI	PAOVF
FFDE, DF	Timer Overflow	I Bit	TOI	TOF
FFE0, E1	Timer Input Capture 4/Output Compare 5	I Bit	I4/O5I	I4/O5F
FFE2, E3	Timer Output Compare 4	I Bit	OC4I	OC4F
FFE4, E5	Timer Output Compare 3	I Bit	OC3I	OC3F
FFE6, E7	Timer Output Compare 2	I Bit	OC2I	OC2F
FFE8, E9	Timer Output Compare 1	I Bit	OC1I	OC1F
FFEA, EB	Timer Input Capture 3	I Bit	IC3I	IC3F
FFEC, ED	Timer Input Capture 2	I Bit	IC2I	IC2F
FFEE, EF	Timer Input Capture 1	I Bit	IC1I	IC1F
FFF0, F1	Real-Time Interrupt	I Bit	RTII	RTIF
FFF2, F3	\overline{IRQ}	I Bit	None	None
FFF4, F5	\overline{XIRQ} Pin	X Bit	None	None
FFF6, F7	Software Interrupt	None	None	None
FFF8, F9	Illegal Opcode Trap	None	None	None
FFFA, FB	COP Failure	None	NOCOP	None
FFFC, FD	Clock Monitor Fail	None	CME	None
FFFE, FF	RESET	None	None	None

5.2 Reset and Interrupt Registers

OPTION — System Configuration Options

\$x039

	Bit 7	6	5	4	3	2	1	Bit 0
	ADPU	CSEL	IRQE*	DLY*	CME	FCME*	CR1*	CR0*
RESET:	0	0	0	1	0	0	0	0

*Can be written only once in first 64 cycles out of reset in normal modes, or at any time in special modes.

Bits [7:6], [4:2]

Refer to **4.3 System Initialization Registers**, page 23, and **11.3 A/D Registers**, page 56.

IRQE — \overline{IRQ} Select Edge Sensitive Only

0 = Low level recognition

1 = Falling edge recognition

CR[1:0] — COP Timer Rate Select

The COP system is driven by a constant frequency of $E/2^{15}$. CR[1:0] specify an additional divide-by factor to arrive at the COP time-out rate.

Table 12 COP Watchdog Time-Out Periods

Frequency	Tolerance	CR[1:0] = 00	CR[1:0] = 01	CR[1:0] = 10	CR[1:0] = 11
1 MHz	-0/+32.768 ms	32.768 ms	131.072 ms	524.288 ms	2.097 s
2 MHz	-0/+16.384 ms	16.384 ms	65.536 ms	262.144 ms	1.049 s
3 MHz	-0/+10.923 ms	10.923 ms	43.691 ms	174.763 ms	699.051 ms
4 MHz	-0/+8.192 ms	8.192 ms	32.768 ms	131.072 ms	524.288 ms
5 MHz	-0/+6.554 ms	6.554 ms	26.214 ms	104.858 ms	419.430 ms
6 MHz	-0/+5.461 ms	5.461 ms	21.845 ms	87.381 ms	349.525 ms
Any E	-0/+2 ¹⁵ /E	2 ¹⁵ /E	2 ¹⁷ /E	2 ¹⁹ /E	2 ²¹ /E

COPRST — Arm/Reset COP Timer Circuitry

\$x03A

	Bit 7	6	5	4	3	2	1	Bit 0
	7	6	5	4	3	2	1	0
RESET:	0	0	0	0	0	0	0	0

Write \$55 to COPRST to arm the COP watchdog clearing mechanism. Then write \$AA to COPRST to reset the COP timer. Performing instructions between these two steps is possible provided both steps are completed in the correct sequence before the timer times out.

HPRIO — Highest Priority I-Bit Interrupt and Miscellaneous

\$x03C

	Bit 7	6	5	4	3	2	1	Bit 0
	RBOOT	SMOD	MDA	IRV	PSEL3	PSEL2	PSEL1	PSEL0
RESET:					0	1	0	1

Bits [7:4] — See 4.3 System Initialization Registers, page 20.

PSEL[3:0] — Interrupt Priority Select Bits

Can be written only while the I bit in the CCR is set (interrupts disabled). These bits select one interrupt source to have priority over other I-bit related sources.

Table 13 Highest Priority Interrupt Selection

PSEL[3:0]	Interrupt Source Promoted
0000	Timer Overflow
0001	Pulse Accumulator Overflow
0010	Pulse Accumulator Input Edge
0011	SPI Serial Transfer Complete
0100	SCI Serial System
0101	Reserved (Default to \overline{IRQ})
0110	\overline{IRQ} (External Pin)
0111	Real-Time Interrupt
1000	Timer Input Capture 1
1001	Timer Input Capture 2
1010	Timer Input Capture 3

Table 13 Highest Priority Interrupt Selection (Continued)

PSEL[3:0]	Interrupt Source Promoted
1011	Timer Output Compare 1
1100	Timer Output Compare 2
1101	Timer Output Compare 3
1110	Timer Output Compare 4
1111	Timer Output Compare 5/Input Capture 4

CONFIG — EEPROM Mapping, COP, EEPROM Enables

\$x03F

	Bit 7	6	5	4	3	2	1	Bit 0
	EE3	EE2	EE1	EE0	1	NOCOP	1	EEON
RESET	U	U	U	U	1	U	1	U

Bits 7:3, 1:0 — See **6.2 EEPROM Registers**, page 30.

NOCOP — COP System Disable

0 = COP enabled (forces reset on time-out)

1 = COP disabled (does not force reset on time-out)

6 Electrically Erasable Programmable ROM

The MC68HC11F1 has 512 bytes of electrically erasable programmable ROM (EEPROM). A nonvolatile, EEPROM-based configuration register (CONFIG) controls whether the EEPROM is present or absent and determines its position in the memory map. In single-chip and bootstrap modes the EEPROM is positioned at \$FE00–\$FFFF. In expanded and special test modes, the EEPROM can be repositioned to any 4-Kbyte boundary (\$xE00–\$xFFF).

NOTE

EEPROM is available on the MC68HC11F1 only.

6.1 EEPROM Operation

The EEON bit in CONFIG controls whether the EEPROM is present in the memory map. When EEON = 1, the EEPROM is enabled. When EEON = 0, the EEPROM is disabled and removed from the memory map. EEON is forced to one out of reset in single-chip and special bootstrap modes to enable EEPROM. EEON is forced to zero out of reset in special test mode to remove EEPROM from the memory map, although test software can turn it back on. In normal expanded mode, EEON is reset to the value last programmed into CONFIG.

An on-chip charge pump develops the high voltage required for programming and erasing. When the E-clock frequency is 1 MHz or above, the charge pump is driven by the E-clock. When the E-clock frequency is less than 1 MHz, select the internal RC oscillator to drive the EEPROM charge pump by writing one to the CSEL bit in the OPTION register. Refer to the discussion of the OPTION register in **4.3 System Initialization Registers**, page 23.

6.2 EEPROM Registers

BPROT — Block Protect

\$x035

	Bit 7	6	5	4	3	2	1	Bit 0
	0	0	0	PTCON	BPRT3	BPRT2	BPRT1	BPRT0
RESET	0	0	0	1	1	1	1	1

Bits [7:5] — Not implemented. Reads always return zero and writes have no effect.

PTCON — Protect for CONFIG

- 0 = CONFIG register can be programmed or erased normally
- 1 = CONFIG register cannot be programmed or erased

BPRT[3:0] — Block Protect Bits for EEPROM

- 0 = Protection disabled
- 1 = Protection enabled

Table 14 Block Protect Bits for EEPROM

Bit Name	Block Protected	Block Size
BPRT3	\$xEE0–xFFF	288 Bytes
BPRT2	\$xE60–xEDF	128 Bytes
BPRT1	\$xE20–xE5F	64 Bytes
BPRT0	\$xE00–xE1F	32 Bytes

NOTE

Block protect register bits can be written to zero (protection disabled) only once within 64 cycles of a reset in normal modes, or at any time in special modes. Block protect register bits can be written to one (protection enabled) at any time.

PPROG — EEPROM Programming Control

\$x03B

	Bit 7	6	5	4	3	2	1	Bit 0
	ODD	EVEN	0	BYTE	ROW	ERASE	EELAT	EEPGM
RESET	0	0	0	0	0	0	0	0

ODD — Program Odd Rows (TEST)

EVEN — Program Even Rows (TEST)

ROW and BYTE — Row Erase Select Bit and Byte Erase Select

The value of these bits determines the manner in which EEPROM is erased. Bit encodings are shown in **6.2 EEPROM Registers**, page 30.

Table 15 ROW and BYTE Encodings

BYTE	ROW	Action
0	0	Bulk Erase (All 512 Bytes)
0	1	Row Erase (16 Bytes)
1	0	Byte Erase
1	1	Byte Erase

ERASE — Erase/Normal Control for EEPROM

- 0 = Normal read or program mode
- 1 = Erase mode

EELAT — EEPROM Latch Control

- 0 = EEPROM address and data bus configured for normal reads
- 1 = EEPROM address and data bus configured for programming or erasing

EEPGM — EEPROM Program Command

- 0 = Program or erase voltage to EEPROM array switched off
- 1 = Program or erase voltage to EEPROM array switched on

CONFIG — EEPROM Mapping, COP, EEPROM Enables

\$x03F

	Bit 7	6	5	4	3	2	1	Bit 0
	EE3	EE2	EE1	EE0	1	NOCOP	1	EEON
RESET	U	U	U	U	1	U	1	U

U = Unaffected by reset.

The CONFIG register is used to assign EEPROM a location in the memory map and to enable or disable EEPROM operation. Bits in this register are user-programmed except when forced to certain values, as noted in the following bit descriptions.

EE[3:0] — EEPROM Map Position

EEPROM is located at \$xE00 – \$xFFF, where x is the value represented by these four bits. In single-chip and bootstrap modes, EEPROM is forced to \$FE00 – \$FFFF, regardless of the state of these bits. On factory-fresh devices, EE[3:0] = \$0.

Bit 3 — Not implemented. Reads always return one and writes have no effect.

NOCOP — COP System Disable

- 0 = COP enabled (forces reset on time-out)
- 1 = COP disabled (does not force reset on time-out)

Bit 1 — Not implemented. Reads always return one and writes have no effect.

EEON — EEPROM Enable

This bit is forced to one in single-chip and bootstrap modes. In test mode, EEON is forced to zero out of reset. In expanded mode, the EEPROM obeys the state of this bit.

0 = EEPROM is removed from the memory map.

1 = EEPROM is present in the memory map.

Refer to **6.4 CONFIG Register Programming** for instructions on programming this register.

6.3 EEPROM Programming and Erasure

Programming and erasing the EEPROM is controlled by the PPROG register, subject to the block protect (BPROT) register value. To erase the EEPROM, ensure that the proper bits of the BPROT register are cleared, and then complete the following steps:

1. Write to PPROG with the ERASE and EELAT bits set and the BYTE and ROW bits set or cleared as appropriate.
2. Write to the appropriate EEPROM address with any data. Row erase (\$xE00–\$xE0F, \$xE10–\$xE1F,... \$xFF0–\$xFFFF) requires a single write to any location in the row. Perform bulk erase by writing to any location in the array.
3. Write to PPROG with the ERASE, EELAT, and EEPGM bits set and the BYTE and ROW bits set or cleared as appropriate.
4. Delay for 10 ms (20 ms for low-voltage operation).
5. Clear the EEPGM bit in PPROG to turn off the high voltage.
6. Clear the PPROG register to reconfigure EEPROM address and data buses for normal operations.

To program the EEPROM, ensure that the proper bits of the BPROT register are cleared, and then complete the following steps:

1. Write to PPROG with the EELAT bit set.
2. Write data to the desired address.
3. Write to PPROG with the EELAT and EEPGM bits set.
4. Delay for 10 ms (20 ms for low-voltage operation).
5. Clear the EEPGM bit in PPROG to turn off the high voltage.
6. Clear the PPROG register to reconfigure EEPROM address and data buses for normal operations.

6.3.1 Programming a Byte

The following example shows how to program an EEPROM byte. This example assumes that the appropriate bits in BPROT are cleared and that the data to be programmed is present in accumulator A.

PROG	LDAB	#\$02	EELAT=1, EEPGM=0
	STAB	\$103B	Set EELAT bit
	STAA	\$FE00	Store data to EEPROM address
	LDAB	#\$03	EELAT=1, EEPGM=1
	STAB	\$103B	Turn on programming voltage
	JSR	DLY10	Delay 10 ms
	CLR	\$103B	Turn off high voltage and set to READ mode

6.3.2 Bulk Erase

The following example shows how to bulk erase the 512-byte EEPROM. The CONFIG register is not affected in this example. Note that when the CONFIG register is bulk erased, CONFIG and the 512-byte array are all erased.

BULKE	LDAB	#\$06	ERASE=1, EELAT=1, EEPGM=0
	STAB	\$103B	Set EELAT bit

STAB	\$FE00	Store any data to any EEPROM address
LDAB	#\$07	EELAT=1, EEPGM=1
STAB	\$103B	Turn on programming voltage
JSR	DLY10	Delay 10 ms
CLR	\$103B	Turn off high voltage and set to READ mode

6.3.3 Row Erase

The following example shows how to perform a fast erase of large sections of EEPROM. This example assumes that index register X contains the address of a location in the desired row.

ROWE	LDAB	#\$0E	ROW=1, ERASE=1, EELAT=1, EEPGM=0
	STAB	\$103B	Set to ROW erase mode
	STAB	\$xxxx	Store any data to any address in ROW
	LDAB	#\$0F	ROW=1, ERASE=1, EELAT=1, EEPGM=1
	STAB	\$103B	Turn on high voltage
	JSR	DLY10	Delay 10 ms
	CLR	\$103B	Turn off high voltage and set to READ mode

6.3.4 Byte Erase

The following is an example of how to erase a single byte of EEPROM. This example assumes that index register X contains the address of the byte to be erased.

BYTEE	LDAB	#\$16	BYTE=1, ROW=0, ERASE=1, EELAT=1, EEPGM=0
	STAB	\$103B	Set to BYTE erase mode
	STAB	\$0,X	Store any data to address to be erased
	LDAB	#\$17	BYTE=1, ROW=0, ERASE=1, EELAT=1, EEPGM=1
	STAB	\$103B	Turn on high voltage
	JSR	DLY10	Delay 10 ms
	CLR	\$103B	Turn off high voltage and set to READ mode

6.4 CONFIG Register Programming

Because the CONFIG register is implemented with EEPROM cells, use EEPROM procedures to erase and program this register. The procedure for programming is the same as for programming a byte in the EEPROM array, except that the CONFIG register address is used. CONFIG can be programmed or erased (including byte erase) while the MCU is operating in any mode, provided that PTCON in BPROT is clear. To change the value in the CONFIG register, complete the following procedure. Do not initiate a reset until the procedure is complete. The new value will not take effect until after the next reset sequence.

1. Erase the CONFIG register.
2. Program the new value to the CONFIG address.
3. Initiate reset.

7 Parallel Input/Output

On the MC68HC11F1, either 54 or 51 pins are available for general-purpose I/O, depending on the package. These pins are arranged into ports A, B, C, D, E, F, and G. On the MC68HC11FC0, either 52 or 49 pins are available, depending on the package.

I/O functions on some ports (B, C, F, and G) are affected by the mode of operation selected. In the single-chip and bootstrap modes, they are configured as parallel I/O data ports. In expanded and test modes, they are configured as follows:

- Ports B and F are configured as the address bus.
- Port C is configured as the data bus.
- Port G bit 7 is configured as the optional program chip select $\overline{\text{CSPROG}}$.

In addition, in expanded and test modes the $\text{R}/\overline{\text{W}}$ signal is configured as data bus direction control. The remaining ports (A, D, and E) are unaffected by mode changes.

7.1 Port A

Port A is an eight-bit general-purpose I/O port (PA[7:0]) with a data register (PORTA) and a data direction register (DDRA). Port A pins are available for shared use among the main timer, pulse accumulator, and general I/O functions, regardless of mode. Four pins can be used for timer output compare functions (OC), three for input capture (IC), and one as either a fourth IC or a fifth OC.

7.2 Port B

Port B is an eight-bit general-purpose output-only port in single-chip modes. In expanded modes, port B pins act as high-order address lines ADDR[15:8], and accesses to PORTB (the port B data register) are mapped externally.

7.3 Port C

Port C is an eight-bit general-purpose I/O port with a data register (PORTC) and a data direction register (DDRC). In single-chip modes, port C pins are general-purpose I/O pins PC[7:0]. Port C can be configured for wired-OR operation in single-chip modes by setting the CWOM bit in the OPT2 register. In expanded modes, port C is the data bus DATA[7:0], and accesses to PORTC (the port C data register) are mapped externally.

7.4 Port D

Port D is a six-bit general-purpose I/O port with a data register (PORTD) and a data direction register (DDRD). In all modes, the six port D lines (PD[5:0]) can be used for general-purpose I/O or for the serial communications interface (SCI) or serial peripheral interface (SPI) subsystems. Port D can also be configured for wired-OR operation.

7.5 Port E

Port E is an eight-bit input-only port that is also used (on the MC68HC11F1 only) as the analog input port for the analog-to-digital converter. Port E pins that are not used for the A/D system can be used as general-purpose inputs. However, PORTE should not be read during the sample portion of an A/D conversion sequence.

NOTE

PE7 and PE0 are not available on the 80-pin MC68HC11FC0. PE7, PE4, and PE0 are not available on the 64-pin MC68HC11FC0.

7.6 Port F

Port F is an eight-bit output-only port. In single-chip mode, port F pins are general-purpose output pins PF[7:0]. In expanded mode, port F pins act as low-order address outputs ADDR[7:0].

7.7 Port G

Port G is an eight-bit general-purpose I/O port with a data register (PORTG) and a data direction register (DDRG). When enabled, the upper four lines (PG[7:4]) can be used as chip-select outputs in expanded modes. When any of these pins are not being used for chip selects, they can be used for general-purpose I/O. Port G can be configured for wired-OR operation by setting the GWOM bit in the OPT2 register.

NOTE

PG[1:0] are not available on the 64-pin MC68HC11FC0.

7.8 Parallel I/O Registers

Port pin function is mode dependent. Do not confuse pin function with the electrical state of the pin at reset. Port pins are either driven to a specified logic level or are configured as high impedance inputs. I/O pins configured as high-impedance inputs have port data that is indeterminate. The contents of the corresponding latches are dependent upon the electrical state of the pins during reset. In port descriptions, an "I" indicates this condition. Port pins that are driven to a known logic level during reset are shown with a value of either one or zero. Some control bits are unaffected by reset. Reset states for these bits are indicated with a "U".

PORTA — Port A Data Register

\$x000

	Bit 7	6	5	4	3	2	1	Bit 0
	PA7	PA6	PA5	PA4	PA3	PA2	PA1	PA0
RESET:	I	I	I	I	I	I	I	I
Alternate Function:	PAI	OC2	OC3	OC4	OC5/IC4	IC1	IC2	IC3
And/or:	OC1	OC1	OC1	OC1	OC1	—	—	—

I = Indeterminate value

DDRA — Port A Data Direction Register

\$x001

	Bit 7	6	5	4	3	2	1	Bit 0
	DDA7	DDA6	DDA5	DDA4	DDA3	DDA2	DDA1	DDA0
RESET:	0	0	0	0	0	0	0	0

For DDRx bits, 0 = input and 1 = output.

PORTG — Port G Data Register

\$x002

	Bit 7	6	5	4	3	2	1	Bit 0
	PG7	PG6	PG5	PG4	PG3	PG2	PG1*	PG0*
RESET:	I	I	I	I	I	I	I	I
Alternate Function:	$\overline{\text{CS}}\text{PROG}$	CSGEN	CSIO1	CSIO2				

*These bits are not present on the 64-pin QFP version of the MC68HC11FC0.

I = Indeterminate value

DDRG — Port G Data Direction Register

\$x003

	Bit 7	6	5	4	3	2	1	Bit 0
	DDG7*	DDG6	DDG5	DDG4	DDG3	DDG2	DDG1	DDG0
RESET:	0	0	0	0	0	0	0	0

* Following reset in expanded and test modes, PG7/CSPRG is configured as a program chip select, forcing the pin to be an output pin, even though the value of the DDG7 bit remains zero.

For DDRx bits, 0 = input and 1 = output.

PORTB — Port B Data Register

\$x004

	Bit 7	6	5	4	3	2	1	Bit 0
	PB7	PB6	PB5	PB4	PB3	PB2	PB1	PB0
RESET:	0	0	0	0	0	0	0	0
Alternate Function:	ADDR15	ADDR14	ADDR13	ADDR12	ADDR11	ADDR10	ADDR9	ADDR8

The reset state of port B is mode dependent. In single-chip or bootstrap modes, port B pins are general-purpose outputs. In expanded and test modes, port B pins are high-order address outputs and PORTB is not in the memory map.

PORTF — Port F Data Register

\$x005

	PF7	PF6	PF5	PF4	PF3	PF2	PF1	PF0
RESET:	0	0	0	0	0	0	0	0
Alternate Function:	ADDR7	ADDR6	ADDR5	ADDR4	ADDR3	ADDR2	ADDR1	ADDR0

The reset state of port F is mode dependent. In single-chip or bootstrap modes, port F pins are general-purpose outputs. In expanded and test modes, port F pins are low-order address outputs and PORTF is not in the memory map.

PORTC — Port C Data Register

\$x006

	Bit 7	6	5	4	3	2	1	Bit 0
	PC7	PC6	PC5	PC4	PC3	PC2	PC1	PC0
RESET:	I	I	I	I	I	I	I	I
Alternate Function:	DATA7	DATA6	DATA5	DATA4	DATA3	DATA2	DATA1	DATA0

The reset state of port C is mode dependent. In single-chip and bootstrap modes, port C pins are high-impedance inputs. In expanded or test modes, port C pins are data bus inputs/outputs and PORTC is not in the memory map. The R/\overline{W} signal is used to control the direction of data transfers.

DDRC — Port C Data Direction Register

\$x007

	Bit 7	6	5	4	3	2	1	Bit 0
	DDC7	DDC6	DDC5	DDC4	DDC3	DDC2	DDC1	DDC0
RESET:	0	0	0	0	0	0	0	0

For DDRx bits, 0 = input and 1 = output.

PORTD — Port D Data Register

\$x008

	Bit 7	6	5	4	3	2	1	Bit 0
	0	0	PD5	PD4	PD3	PD2	PD1	PD0
RESET:	0	0	1	1	1	1	1	1
Alternate Function:	—	—	\overline{SS}	SCK	MOSI	MISO	TxD	RxD

DDRD — Port D Data Direction Register

\$x009

	Bit 7	6	5	4	3	2	1	Bit 0
	0	0	DDD5	DDD4	DDD3	DDD2	DDD1	DDD0
RESET:	0	0	0	0	0	0	0	0

For DDRx bits, 0 = input and 1 = output.

NOTE

When the SPI system is in slave mode, DDD5 has no meaning or effect. When the SPI system is in master mode, DDD5 determines whether bit 5 of PORTD is an error detect input (DDD5 = 0) or a general-purpose output (DDD5 = 1). If the SPI system is enabled and expects one or more of bits [4:2] to be inputs, those bits will be inputs regardless of the state of the associated DDR bits. If one or more of bits [4:2] are expected to be outputs, those bits will be outputs only if the associated DDR bits are set.

PORTE — Port E Data

\$x00A

	Bit 7	6	5	4	3	2	1	Bit 0
	PE7 ¹	PE6	PE5	PE4 ²	PE3	PE2	PE1	PE0 ¹
RESET:	U	U	U	U	U	U	U	U
Alternate Function	AN7	AN6	AN5	AN4	AN3	AN2	AN1	AN0

NOTES:

1. These bits are not present on the MC68HC11FC0 and will always read zero.
2. This bit is not present on the 64-pin QFP version of the MC68HC11FC0 and will always read zero.

U = Unaffected by rest.

PORTE is an input-only register. Reads return the digital state of the I/O pins, and writes have no effect. On the MC68HC11F1, port E is shared with the analog-to-digital converter. (The A/D converter is not present on the MC68HC11FC0.)

OPT2 — System Configuration Option Register 2

\$x038

	Bit 7	6	5	4	3	2	1	Bit 0
	GWOM	CWOM	CLK4X	LIRDV	—	SPRBYP	—	—
RESET	0	0	1	0	0	0	0	0

GWOM — Port G Wired-OR Mode Option

This bit affects all port G pins together.

- 0 = Port G outputs are normal CMOS outputs
- 1 = Port G outputs act as open-drain outputs

Freescale Semiconductor, Inc.

CWOM — Port C Wired-OR Mode Option

This bit affects all port C pins together.

0 = Port C outputs are normal CMOS outputs

1 = Port C outputs act as open-drain outputs

CLK4X — 4XCLK Output Enable

Refer to **4.3 System Initialization Registers**, page 23

LIRDV — Load Instruction Register Driven

Refer to **4.3 System Initialization Registers**, page 23

Bits 3, 1, 0 — Not implemented. Reads always return zero and writes have no effect.

SPRBYP — Refer to **10.2 SPI Registers**, page 52.

8 Chip-Selects

Chip selects eliminate the need for additional external components to interface with peripherals in expanded non-multiplexed modes. Chip-select registers control polarity, address block size, base address, and clock stretching.

8.1 Chip-Select Operation

There are four programmable chip selects on the MC68HC11F1 and MC68HC11FC0: two for external I/O (CSIO1 and CSIO2), one for external program space ($\overline{\text{CSPROG}}$), and one general-purpose chip select (CSGEN).

$\overline{\text{CSPROG}}$ is active low and becomes active at address valid time. $\overline{\text{CSPROG}}$ is enabled by the PCSEN bit of the chip-select control register (CSCTL). Its address block size is selected by the PSIZA and PSIZB bits of CSCTL.

Use the I/O chip selects (CSIO1 and CSIO2) for external I/O devices. These chip-select addresses are found in the memory map block that contains the status and control registers. CSIO1 is mapped from \$x060 to \$x7FF, and CSIO2 is mapped from \$x800 to \$xFFF, where x represents the REG[3:0] bits of the INIT register on the MC68HC11F1 or the REG[1:0] bits of the INIT register on the MC68HC11FC0. Polarity and enable-disable selections are controlled by CSCTL register bits IO1EN, IO1PL, IO2EN, and IO2PL. The IO1AV and IO2AV bits of the CSGSIZ register determine whether the chip selects are valid during address or E-clock valid times.

The general-purpose chip select is the most flexible of the four chip selects. Polarity, valid assertion time, and block size are determined by the GNPOL, GAVLD, GSIZA, GSIZB, and GSIZC bits of the CSGSIZ register. The starting address is selected with the CSGADR register.

Each of the four chip selects has two associated bits in the chip-select clock stretch register (CSSTRH). These bits allow clock stretching from zero to three cycles (full E-clock periods) to accommodate slow device interfaces. Any of the chip selects can be programmed to cause a clock stretch to occur only during access to addresses that fall within that particular chip select's address range.

During the stretch period, the E-clock is held high and the bus remains in the state that it is normally in at the end of E high time. Internally, the clocks continue to run, which maintains the integrity of the timers and baud-rate generators.

Priority levels are assigned to prevent the four chip selects from conflicting with each other or with internal memory and registers. There are two sets of priorities controlled by the value of the general-purpose chip-select priority bit (GCSPR) of the CSCTL register. Refer to **Table 17**.

8.2 Chip-Select Registers

CSSTRH — Clock Stretching **\$x05C**

	Bit 7	6	5	4	3	2	1	Bit 0
	IO1SA	IO1SB	IO2SA	IO2SB	GSTHA	GSTHB	PSTHA	PSTHB
RESET:	0	0	0	0	0	0	0	0

IO1SA, IO1SB — I/O Chip-Select 1 Clock Stretch

IO2SA, IO2SB — I/O Chip-Select 2 Clock Stretch

GSTHA, GSTHB — General-Purpose Chip-Select Clock Stretch

PSTHA, PSTHB — Program Chip-Select Clock Stretch

Each pair of bits selects the number of clock cycles of stretch for the corresponding chip select.

Table 16 Chip Select Clock Stretch Control

Clock Stretch Bits A, B	Clock Stretch
0 0	0 Cycles
0 1	1 Cycle
1 0	2 Cycles
1 1	3 Cycles

CSCTL — Chip-Select Control

\$x05D

	Bit 7	6	5	4	3	2	1	Bit 0
	IO1EN	IO1PL	IO2EN	IO2PL	GCSPR	PCSEN*	PSIZA	PSIZB
RESET:	0	0	0	0	0	—	0	0

* PCSEN is set out of reset in expanded modes and cleared in single-chip modes.

IO1EN — I/O Chip-Select 1 Enable

- 0 = CSIO1 disabled
- 1 = CSIO1 enabled

IO1PL — I/O Chip-Select 1 Polarity

- 0 = CSIO1 active low
- 1 = CSIO1 active high

IO2EN — I/O Chip-Select 2 Enable

- 0 = CSIO2 disabled
- 1 = CSIO2 enabled

IO2PL — I/O Chip-Select 2 Polarity

- 0 = CSIO2 active low
- 1 = CSIO2 active high

GCSPR — General-Purpose Chip-Select Priority

- 0 = Program chip-select has priority over general-purpose chip-select
- 1 = General-purpose chip-select has priority over program chip-select

Refer to **Table 17**.

Table 17 Chip Select Priorities

GCSPR = 0	GCSPR = 1
On-Chip Registers	On-Chip Registers
On-Chip RAM	On-Chip RAM
Bootloader ROM	Bootloader ROM
On-Chip EEPROM ¹	On-Chip EEPROM ¹
I/O Chip Selects	I/O Chip Selects
Program Chip Select	General-Purpose Chip Select
General-Purpose Chip Select	Program Chip Select

NOTES:

1. EEPROM is present on the MC68HC11F1 only.

PCSEN — Program Chip-Select Enable

Reset clears PCSEN in single-chip modes and sets PCSEN in expanded modes.

0 = CSPROG disabled

1 = CSPROG enabled

PSIZA, PSIZB — Select Size of Program Chip-Select

Table 18 Program Chip Select Size Control

PSIZA	PSIZB	Size	Address Range
0	0	64 Kbytes	\$0000–\$FFFF
0	1	32 Kbytes	\$8000–\$FFFF
1	0	16 Kbytes	\$C000–\$FFFF
1	1	8 Kbytes	\$E000–\$FFFF

CSGADR — General-Purpose Chip-Select Address Register

\$x05E

	Bit 7	6	5	4	3	2	1	Bit 0
	GA15	GA14	GA13	GA12	GA11	GA10	—	—
RESET:	0	0	0	0	0	0	0	0

GA[15:10] — General-Purpose Chip-Select Starting Address

These bits determine the starting address of the CSGEN valid address space and correspond to the high-order address bits ADDR[15:10]. **Table 19** illustrates how the block size selected determines which of this register's bits are valid.

Table 19 General Purpose Chip Select Starting Address

CSGEN Block Size	CSGADR Bits Valid
0 Kbytes	None
1 Kbyte	GA15 – GA10
2 Kbytes	GA15 – GA11
4 Kbytes	GA15 – GA12
8 Kbytes	GA15 – GA13
16 Kbytes	GA15 – GA14
32 Kbytes	GA15
64 Kbytes	None

Bits [1:0] — Not implemented. Reads always return zero and writes have no effect.

CSGSIZ — General-Purpose Chip-Select Size Register

\$x05F

	Bit 7	6	5	4	3	2	1	Bit 0
	IO1AV	IO2AV	—	GNPOL	GAVLD	GSIZA	GSIZB	GSIZC
RESET:	0	0	0	0	0	1	1	1

IO1AV — I/O Chip-Select 1 Address Valid

0 = CSIO1 is valid during E-clock valid time (E-clock high)

1 = CSIO1 is valid during address valid time

IO2AV — I/O Chip-Select 2 Address Valid

0 = CSIO2 is valid during E-clock valid time (E-clock high)

1 = CSIO2 is valid during address valid time

Bit 5 — Not implemented. Reads always return zero and writes have no effect.

GNPOL — General-Purpose Chip-Select Polarity

0 = CSGEN is active low

1 = CSGEN is active high

GAVLD — General-Purpose Chip-Select Address Valid

0 = CSGEN is valid during E-clock valid time (E-clock high)

1 = CSGEN is valid during address valid time

GSIZ[A:C] — Block Size for CSGEN

Refer to **Table 20** for bit values.

Table 20 General-Purpose Chip Select Size Control

GSIZ[A:C]	Address Size
000	64 Kbytes
001	32 Kbytes
010	16 Kbytes
011	8 Kbytes
100	4 Kbytes
101	2 Kbytes
110	1 Kbyte
111	0 Kbytes (disabled)

9 Serial Communications Interface (SCI)

The SCI, a universal asynchronous receiver transmitter (UART) serial communications interface, is one of two independent serial I/O subsystems in the MC68HC11F1 and MC68HC11FC0. The SCI has a standard non-return to zero (NRZ) format (one start bit, eight or nine data bits, and one stop bit) and several selectable baud rates. The transmitter and receiver are independent but use the same data format and bit rate.

9.1 SCI Block Diagrams

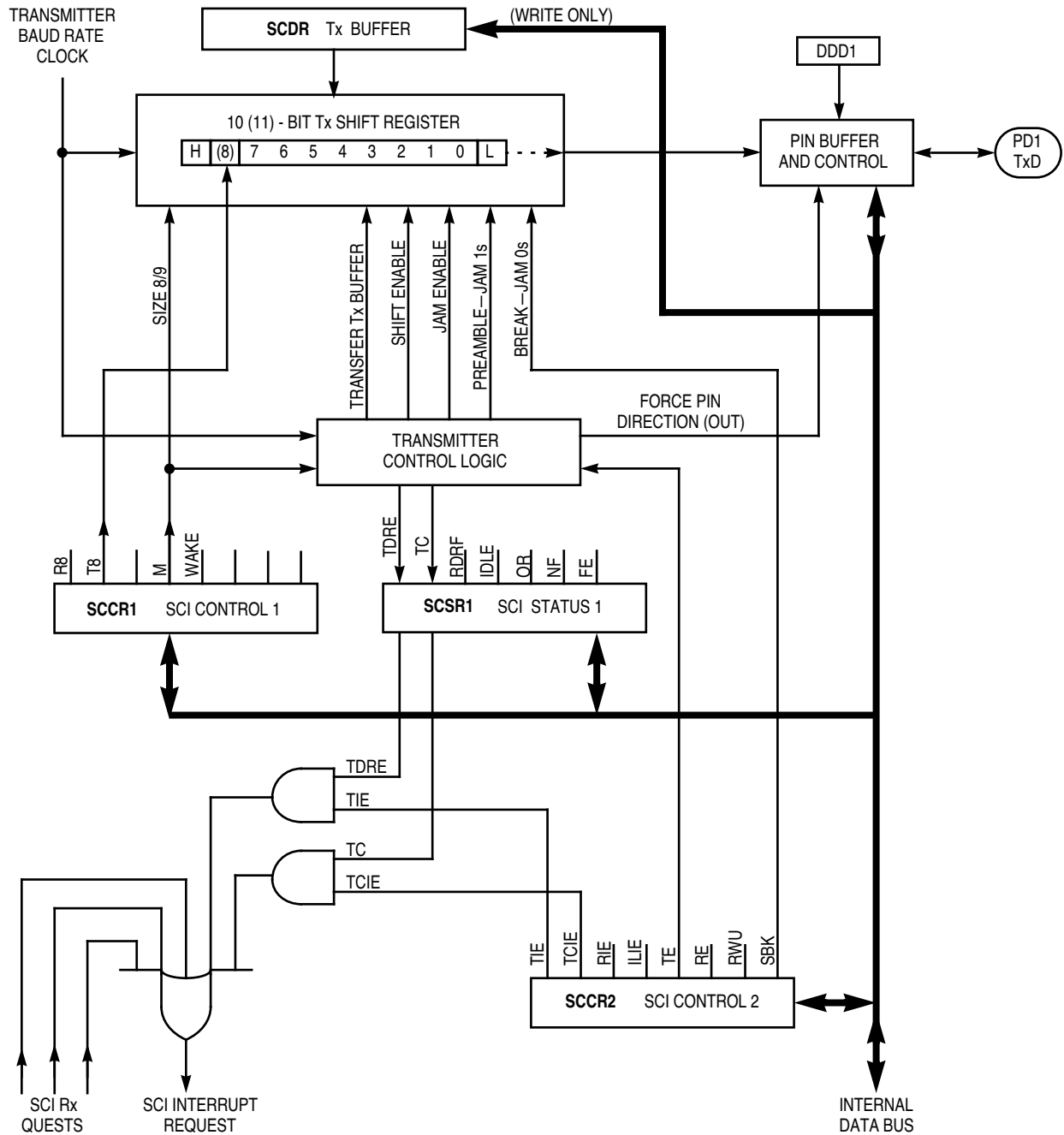

Figure 9 SCI Transmitter Block Diagram

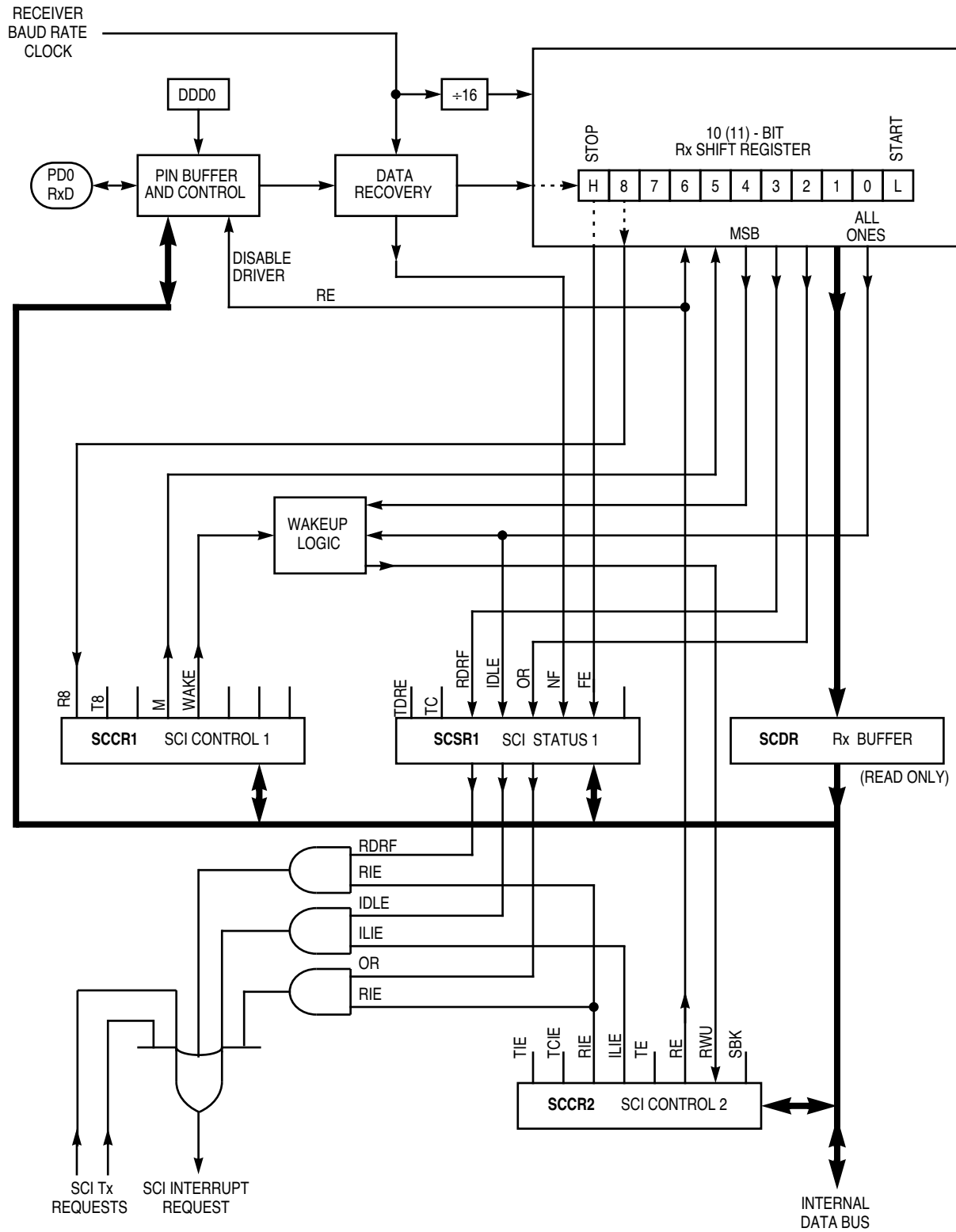

Figure 10 SCI Receiver Block Diagram

9.2 SCI Registers

BAUD — Baud Rate

\$x02B

	Bit 7	6	5	4	3	2	1	Bit 0
	TCLR	SCP2	SCP1	SCP0	RCKB	SCR2	SCR1	SCR0
RESET:	0	0	0	0	0	U	U	U

TCLR — Clear Baud Rate Counters (TEST)

Bit 6 — Not implemented. Reads always return zero and writes have no effect.

RCKB — SCI Baud-Rate Clock Check (TEST)

SCP[2:0] — SCI Baud Rate Prescaler Selects

These bits determine the baud rate prescaler frequency. Refer to **Table 21** and **Figure 11**.

SCR[2:0] — SCI Baud Rate Selects

These bits determine the receiver and transmitter baud rate. Refer to **Table 22** and **Figure 11**.

Table 21 Baud Rate Prescaler Selection

SCP[2:0]	Divide Internal Clock By	Prescaler Output ¹							
		XTAL = 4.0 MHz	XTAL = 4.9152 MHz	XTAL = 8.0 MHz	XTAL = 10.0 MHz	XTAL = 12.0 MHz	XTAL = 16.0 MHz	XTAL = 20.0 MHz	XTAL = 24.0 MHz
X00	1	62500	76800	125000	156250	187500	250000	312500	375000
001	3	20833	25600	41667	52083	62500	83333	104167	125000
X10	4	15625	19200	31250	38400	46875	62500	76800	93750
X11	13	4800	5908	9600	12019	14423	19200	24038	28846
101	9	—	—	—	—	20830	—	—	—

NOTES:

1. A blank table cell indicates that an uncommon rate results.

Table 22 Baud Rate Selection

SCR[2:0]	Divide Prescaler By	Baud Rate				
		Prescaler Output = 4800	Prescaler Output = 9600	Prescaler Output = 19200	Prescaler Output = 38400	Prescaler Output = 76800
0 0 0	1	4800	9600	19200	38400	76800
0 0 1	2	2400	4800	9600	19200	38400
0 1 0	4	1200	2400	4800	9600	19200
0 1 1	8	600	1200	2400	4800	9600
1 0 0	16	300	600	1200	2400	4800
1 0 1	32	150	300	600	1200	2400
1 1 0	64	75	150	300	600	1200
1 1 1	128	—	75	150	300	600

The prescaler bits SCP[2:0] determine the highest baud rate, and the SCR[2:0] bits select an additional binary submultiple (divide by 1, 2, 4,..., through 128) of this highest baud rate. The result of these two dividers in series is the 16X receiver baud rate clock. The SCR[2:0] bits are not affected by reset and can be changed at any time. They should not be changed, however, when an SCI transfer is in progress.

Figure 11 illustrates the SCI baud rate timing chain. The prescaler select bits determine the highest baud rate. The rate select bits determine additional divide-by-two stages to arrive at the receiver timing (RT) clock rate. The baud rate clock is the result of dividing the RT clock by 16.

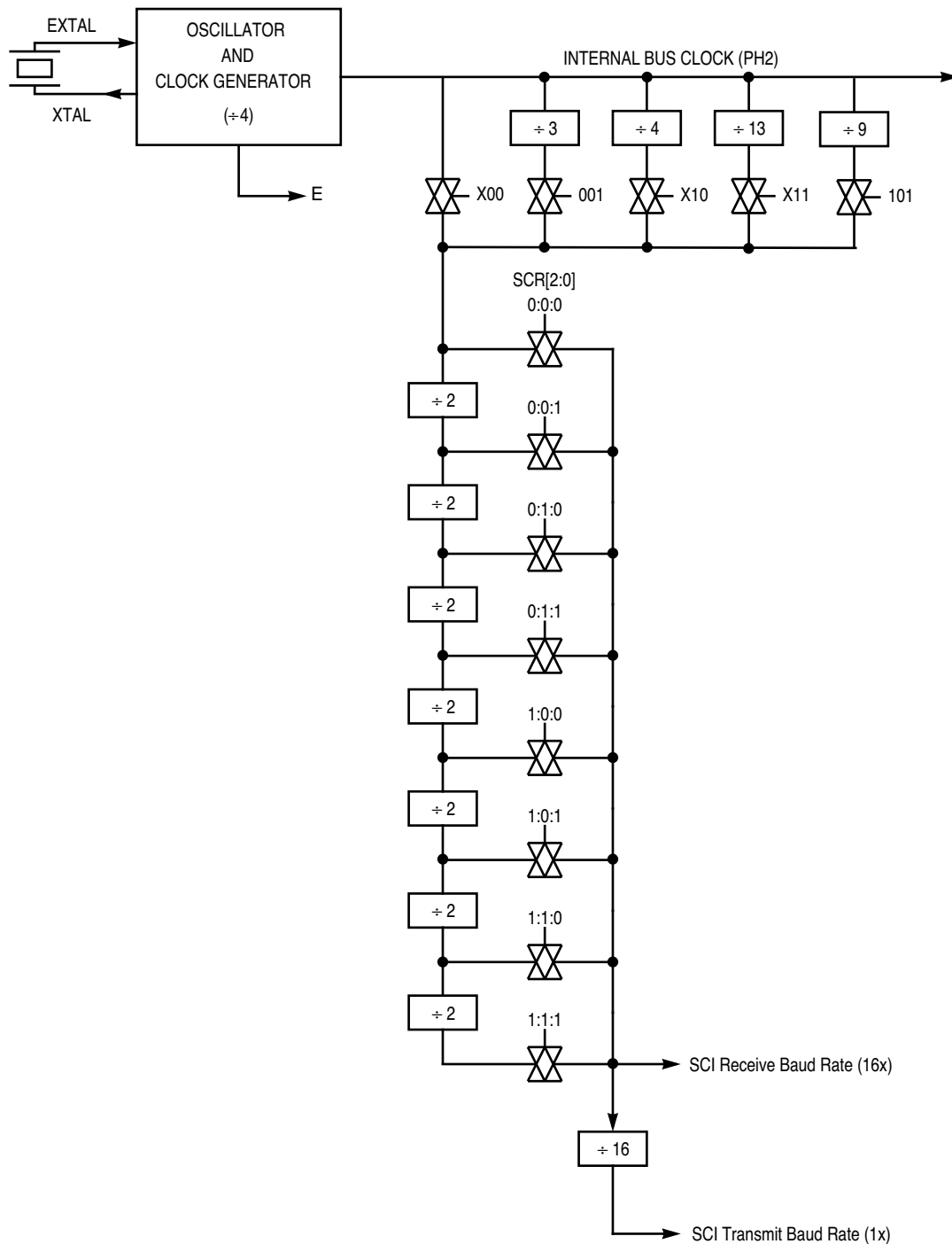

Figure 11 SCI Baud Rate Generator Block Diagram

SCCR1 — SCI Control Register 1

\$x02C

	Bit 7	6	5	4	3	2	1	Bit 0
	R8	T8	0	M	WAKE	0	0	0
RESET:	U	U	0	0	0	0	0	0

U = Unaffected by reset

R8 — Receive Data Bit 8

If M is set, R8 stores the ninth bit of the receive data character.

T8 — Transmit Data Bit 8

If M is set, T8 stores the ninth bit of the transmit data character.

Bit 5 — Not implemented. Reads always return zero and writes have no effect.

M — Mode (Select Character Format)

- 0 = 1 start bit, 8 data bits, 1 stop bit
- 1 = 1 start bit, 9 data bits, 1 stop bit

WAKE — Wake Up by Address Mark/Idle

- 0 = Wake up by IDLE line recognition
- 1 = Wake up by address mark

Bits [2:0] — Not implemented. Reads always return zero and writes have no effect.

SCCR2 — SCI Control Register 2

\$x02D

	Bit 7	6	5	4	3	2	1	Bit 0
	TIE	TCIE	RIE	ILIE	TE	RE	RWU	SBK
RESET:	0	0	0	0	0	0	0	0

TIE — Transmit Interrupt Enable

- 0 = TDRE interrupts disabled
- 1 = SCI interrupt requested when the TDRE flag is set

TCIE — Transmit Complete Interrupt Enable

- 0 = TC interrupts disabled
- 1 = SCI interrupt requested when the TC flag is set

RIE — Receiver Interrupt Enable

- 0 = RDRF and OR interrupts disabled
- 1 = SCI interrupt requested when the RDRF flag or the OR flag is set

ILIE — Idle Line Interrupt Enable

- 0 = IDLE interrupts disabled
- 1 = SCI interrupt requested when IDLE status flag is set

TE — Transmitter Enable

When TE goes from zero to one, one unit of idle character time (logic one) is queued as a preamble.

- 0 = Transmitter disabled
- 1 = Transmitter enabled

RE — Receiver Enable

- 0 = Receiver disabled
- 1 = Receiver enabled

RWU — Receiver Wake Up Control
 0 = Normal SCI receiver
 1 = Wake up enabled and receiver interrupt inhibited

SBK — Send Break
 0 = Break generator off
 1 = Break codes generated as long as SBK = 1

SCSR — SCI Status Register **\$x02E**

	Bit 7	6	5	4	3	2	1	Bit 0
	TDRE	TC	RDRF	IDLE	OR	NF	FE	0
RESET:	1	1	0	0	0	0	0	0

TDRE — Transmit Data Register Empty Flag
 This flag is set when SCDR is empty. Clear the TDRE flag by reading SCSR with TDRE set and then writing to SCDR.
 0 = SCDR is busy
 1 = SCDR is empty

TC — Transmit Complete Flag
 This flag is set when the transmitter is idle (no data, preamble, or break transmission in progress). Clear the TC flag by reading SCSR with TC set and then writing to SCDR.
 0 = Transmitter is busy
 1 = Transmitter is idle

RDRF — Receive Data Register Full Flag
 This flag is set if a received character is ready to be read from SCDR. Clear the RDRF flag by reading SCSR with RDRF set and then reading SCDR.
 0 = SCDR empty
 1 = SCDR full

IDLE — Idle Line Detected Flag
 This flag is set if the RxD line is idle. Once cleared, IDLE is not set again until the RxD line has been active and becomes idle again. The IDLE flag is inhibited when RWU = 1. Clear IDLE by reading SCSR with IDLE set and then reading SCDR.
 0 = RxD line is active
 1 = RxD line is idle

OR — Overrun Error Flag
 OR is set if a new character is received before a previously received character is read from SCDR. Clear OR by reading SCSR with OR set and then reading SCDR.
 0 = No overrun detected
 1 = Overrun detected

NF — Noise Error Flag
 NF is set if majority sample logic detects anything other than a unanimous decision. Clear NF by reading SCSR with NF set and then reading SCDR.
 0 = Unanimous decision
 1 = Noise detected

FE — Framing Error
 FE is set when a zero is detected where a stop bit was expected. Clear the FE flag by reading SCSR with FE set and then reading SCDR.
 0 = Stop bit detected
 1 = Zero detected

Freescale Semiconductor, Inc.

Bit 0 — Not implemented. Reads always return zero and writes have no effect.

SCDR — Serial Communications Data Register

\$x02F

	Bit 7	6	5	4	3	2	1	Bit 0
	Bit 7	6	5	4	3	2	2	Bit 0
RESET:	I	I	I	I	I	I	I	I

I = Indeterminate value

Reading SCDR retrieves the last byte received in the receive data buffer. Writing to SCDR loads the transmit data buffer with the next byte to be transmitted.

10 Serial Peripheral Interface

The serial peripheral interface (SPI) allows the MCU to communicate synchronously with peripheral devices and other microprocessors. The SPI protocol facilitates rapid exchange of serial data between devices in a control system. The MC68HC11F1 and MC68HC11FC0 can be set up for master or slave operation. Standard data rates can be as high as one half of the E-clock rate when configured as master, and as fast as the E-clock when configured as slave.

The MC68HC11FC0 has an additional control bit that allows the SPI baud rate counter to be bypassed. This allows a master mode baud rate equal to the E-clock frequency.

10.1 SPI Block Diagram

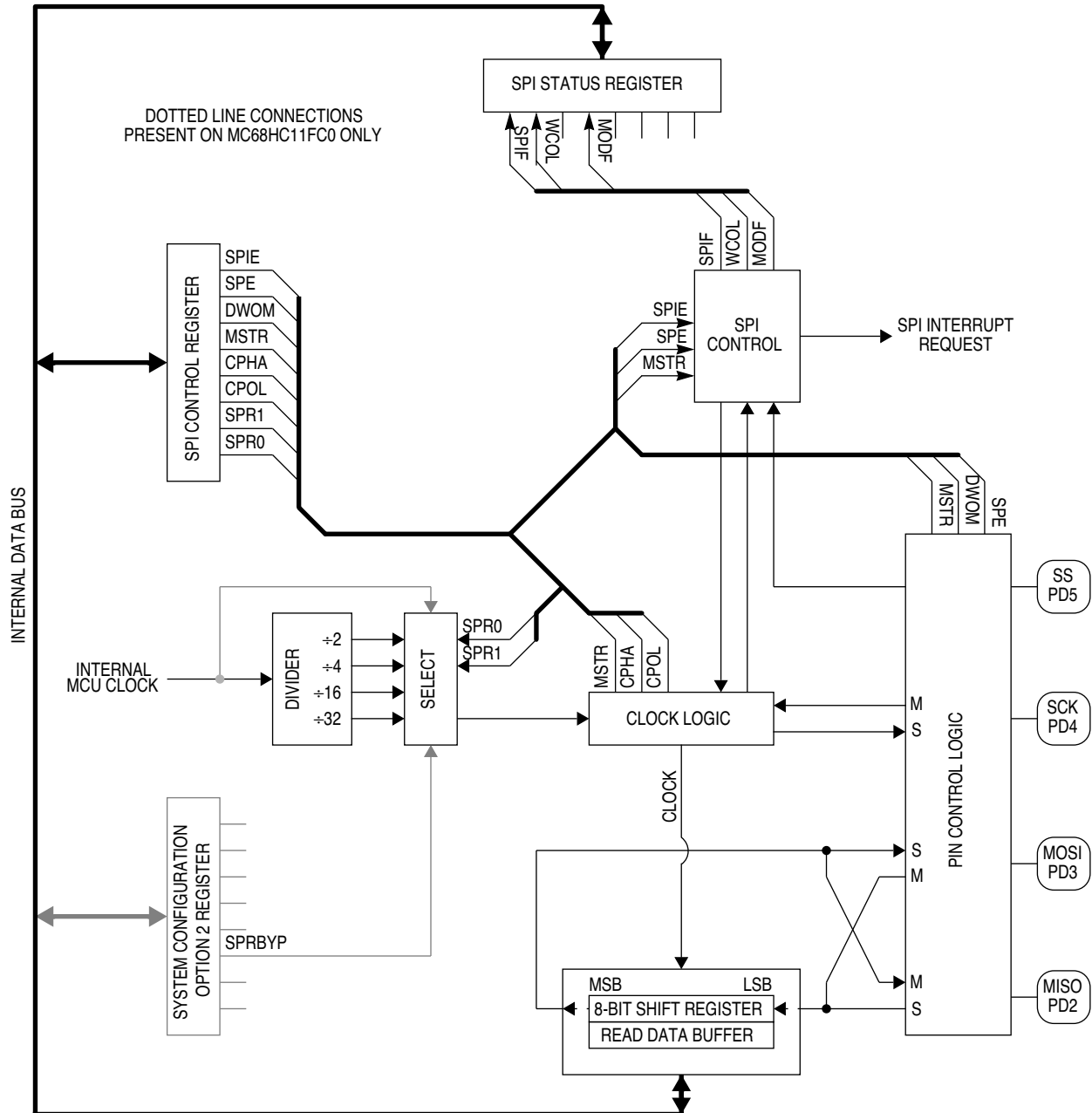

Figure 12 SPI Block Diagram

10.2 SPI Registers

SPCR — SPI Control Register

\$x028

	Bit 7	6	5	4	3	2	1	Bit 0
	SPIE	SPE	DWOM	MSTR	CPOL	CPHA	SPR1	SPR0
RESET:	0	0	0	0	0	1	U	U

U = Unaffected by reset

SPIE — SPI Interrupt Enable

When SPI interrupts are enabled, a hardware interrupt sequence is requested each time the SPIF or MODF status flag is set. SPI interrupts are inhibited if this bit is cleared or if the I bit in the condition code register is one.

- 0 = SPI interrupt disabled
- 1 = SPI interrupt enabled

SPE — SPI Enable

When the SPE bit is set, PD[5:2] are dedicated to the SPI function. If the SPI is in master mode and the DDRD bit 5 is set, then PD5/ \overline{SS} becomes a general-purpose output instead of the \overline{SS} input.

- 0 = SPI off
- 1 = SPI on

DWOM — Port D Wired-OR Mode Option for SPI Pins PD[5:2]

- 0 = Normal CMOS outputs
- 1 = Open-drain outputs

MSTR — Master Mode Select

- 0 = Slave mode
- 1 = Master mode

CPOL — Clock Polarity

When the clock polarity bit is cleared and data is not being transferred, the SCK pin of the master device has a steady state low value. When CPOL is set, SCK idles high. Refer to **Figure 13**.

CPHA — Clock Phase

The clock phase bit, in conjunction with the CPOL bit, controls the clock-data relationship between master and slave. The CPHA bit selects one of two clocking protocols. Refer to **Figure 13**.

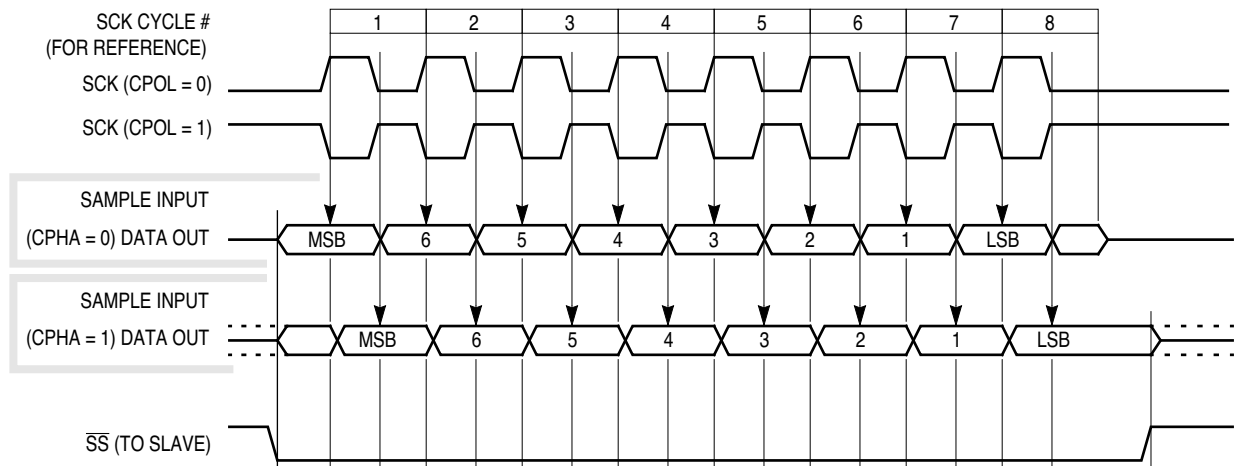

Figure 13 SPI Data Clock Timing Diagram

SPR[1:0] — SPI Clock Rate Selects

These two bits select the SPI clock (SCK) rate when the device is configured as a master. When the device is configured as a slave, the bits have no effect. Refer to **Table 23**.

Table 23 SPI Baud Rates

Input Frequency	SPR[1:0] = 00	SPR[1:0] = 01	SPR[1:0] = 10	SPR[1:0] = 11
1 MHz	500 kbps	250 kbps	62.5 kbps	31.25 kbps
2 MHz	1 Mbps	500 kbps	125 kbps	62.5 kbps
3 MHz	1.5 Mbps	750 kbps	187.5 kbps	93.75 kbps
4 MHz	2 Mbps	1 Mbps	250 kbps	125 kbps
5 MHz	2.5 Mbps	1.25 Mbps	312.5 kbps	156.25 kbps
6 MHz	3 Mbps	1.5 Mbps	375 kbps	187.5 kbps
Any E	E/2	E/4	E/16	E/32

NOTE

The SPRBYP bit in OPT2 on the MC68HC11FC0 allows the SPI baud rate counter to be bypassed. This permits a maximum master mode baud rate equal to the E-clock frequency on the MC68HC11FC0. **SPRBYP is not present on the MC68HC11F1.**

SPSR — SPI Status Register

\$x029

	Bit 7	6	5	4	3	2	1	Bit 0
	SPIF	WCOL	0	MODF	0	0	0	0
RESET:	0	0	0	0	0	0	0	0

SPIF — SPI Transfer Complete Flag

SPIF is set when an SPI transfer is complete. It is cleared by reading SPSR with SPIF set, followed by a read or write of SPDR.

WCOL — Write Collision

WCOL is set when SPDR is written while a transfer is in progress. It is cleared by reading SPSR with WCOL set, followed by a read or write of SPDR.

- 0 = No write collision
- 1 = Write collision

Bit 5 — Not Implemented. Reads always return zero and writes have no effect.

MODF — Mode Fault

A mode fault terminates SPI operation. Set when \overline{SS} is pulled low while MSTR = 1. MODF is cleared by reading SPSR read with MODF set, followed by a write to SPCR.

- 0 = No mode fault
- 1 = Mode fault

Bits [3:0] — Not Implemented. Reads always return zero and writes have no effect.

SPDR — SPI Data Register

\$x02A

Bit 7	6	5	4	3	2	1	Bit 0
Bit 7	6	5	4	3	2	1	Bit 0

Incoming SPI data is double buffered. Outgoing SPI data is single buffered.

OPT2 — System Configuration Option Register 2

\$x038

	Bit 7	6	5	4	3	2	1	Bit 0
	GWOM	CWOM	CLK4X	LIRDV	—	SPRBYP	—	—
RESET	0	0	1	0	0	0	0	0

Bits [7:4] — See **4.3 System Initialization Registers**, page 22.

Bits 3, 1, 0 — Not implemented. Reads always return zero and writes have no effect.

SPRBYP — SPI Baud Rate Counter Bypass

0 = Enable SPI baud rate counter

1 = Bypass SPI baud rate counter

When the SPI baud rate counter is bypassed, the SPI can transmit at a maximum master mode baud rate equal to the E-clock frequency. **SPRBYP is present only on the MC68HC11FC0 and overrides the setting of SPR[1:0] in SPCR.**

11 Analog-to-Digital Converter

The MC68HC11F1 analog-to-digital (A/D) converter system uses an all-capacitive charge-redistribution technique to convert analog signals to digital values. The A/D system is an 8-channel, 8-bit, multiplexed-input, successive-approximation converter, accurate to ± 1 least significant bit (LSB). Because the capacitive charge redistribution technique used includes a built-in sample-and-hold, no external sample-and-hold is required.

Dedicated lines V_{RH} and V_{RL} provide the reference supply voltage inputs. Systems operating at clock rates of 750 kHz or below must use an internal RC oscillator. The CSEL bit in the OPTION register selects the clock source for the A/D system. (The CSEL bit is described in **11.3 A/D Registers**, page 56.)

A multiplexer allows the single A/D converter to select one of 16 analog signals, as shown in **Table 24**.

NOTE

The A/D converter is present on the MC68HC11F1 only.

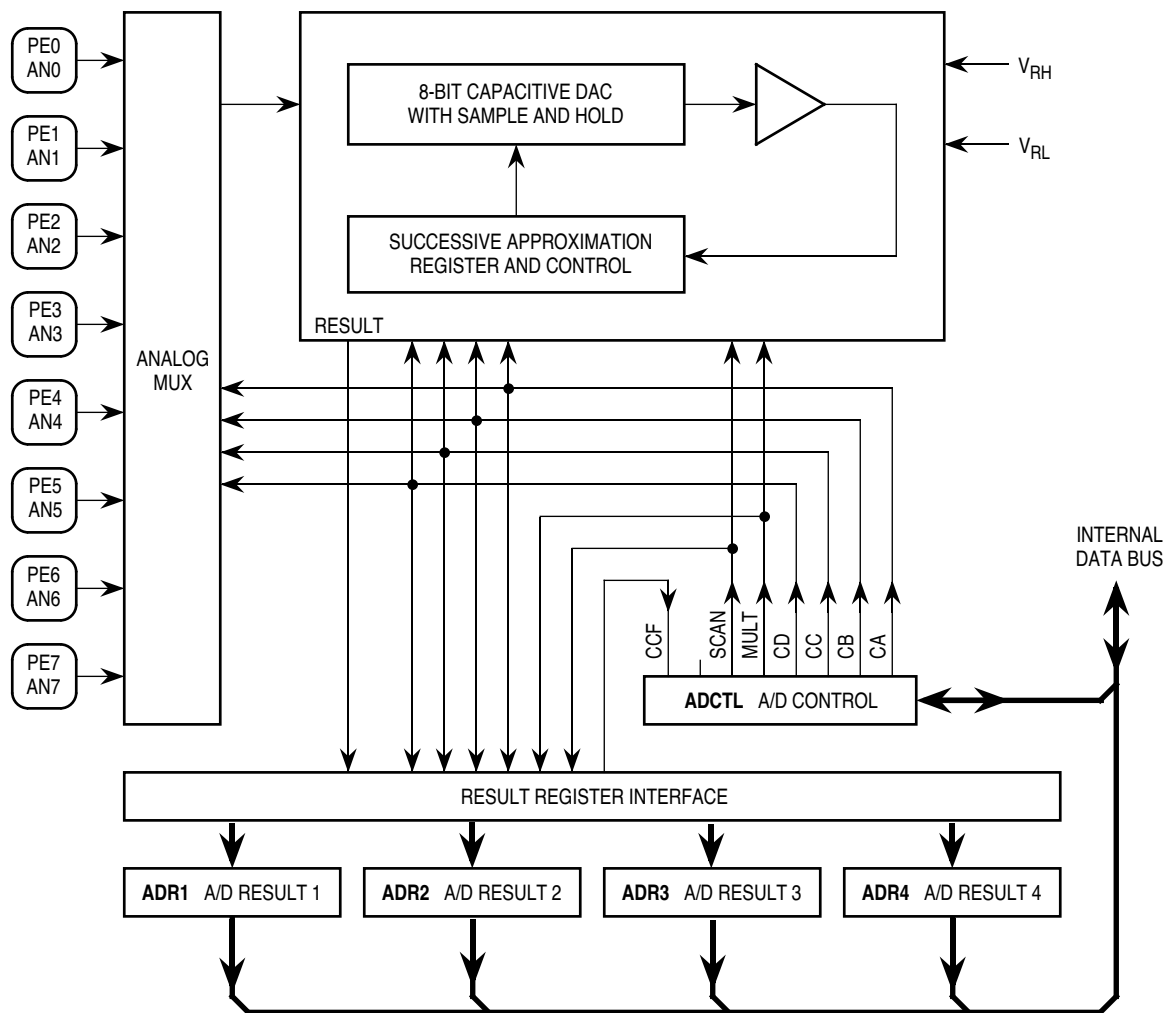

E49 A/D BLOCK

Figure 14 A/D Converter Block Diagram

11.1 Input Pins

Port E pins can also be used as digital inputs. Reads of port E pins are not recommended during the sample portion of an A/D conversion cycle, when the gate signal to the N-channel input gate is on. Because no P-channel devices are directly connected to either input pins or reference voltage pins, voltages above V_{DD} do not cause a latchup problem, although current should be limited according to maximum ratings. **Figure 15** is a functional diagram of an input pin.

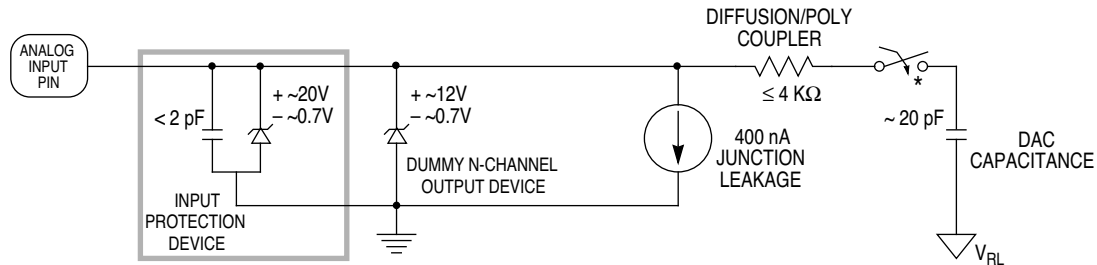

* THIS ANALOG SWITCH IS CLOSED ONLY DURING THE 12-CYCLE SAMPLE TIME.

Figure 15 Electrical Model of an Analog Input Pin (Sample Mode)

11.2 Conversion Sequence

A/D converter operations are performed in sequences of four conversions each. A conversion sequence can be repeated continuously or stop after one iteration. The conversion complete flag (CCF) is set after the fourth conversion in a sequence to show the availability of data in the result registers. **Figure 16** shows the timing of a typical sequence. Synchronization is referenced to the system E clock.

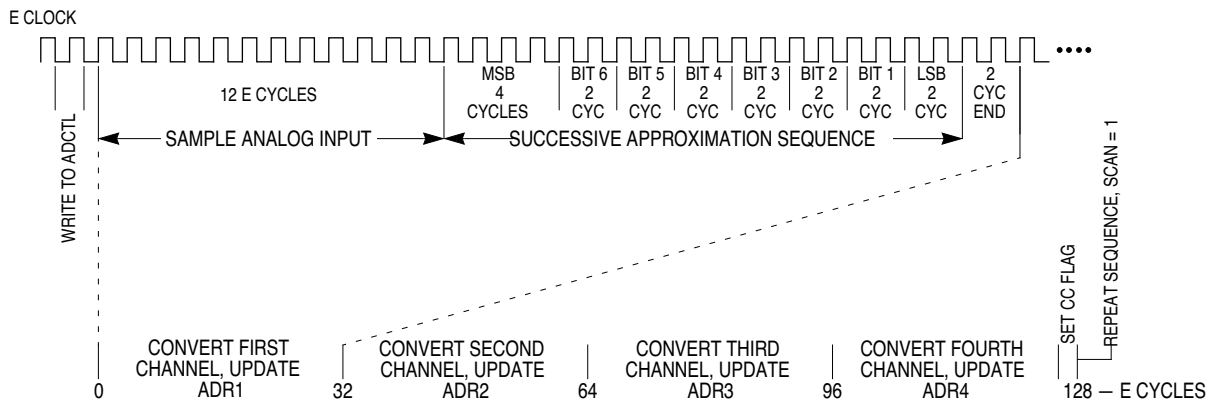

Figure 16 A/D Conversion Sequence

11.3 A/D Registers

ADCTL — A/D Control/Status

\$x030

	Bit 7	6	5	4	3	2	1	Bit 0
	CCF	0	SCAN	MULT	CD	CC	CB	CA
RESET:		0						

| = Indeterminate value

CCF — Conversions Complete Flag

A read-only status indicator, this bit is set when all four A/D result registers contain valid conversion results. Each time the ADCTL register is overwritten, this bit is automatically cleared to zero and a conversion sequence is started. In the continuous mode, CCF is set at the end of the first conversion sequence.

Bit 6 — Not implemented. Reads always return zero and writes have no effect.

SCAN — Continuous Scan Control

- 0 = Do four conversions and stop
- 1 = Convert four channels in selected group continuously

MULT — Multiple Channel/Single Channel Control

- 0 = Convert single channel selected
- 1 = Convert four channels in selected group

CD–CA — Channel Select D through A

Refer to **Table 24**. When a multiple channel mode is selected (MULT = 1), the two least significant channel select bits (CB and CA) have no meaning and the CD and CC bits specify which group of four channels is to be converted.

Table 24 A/D Converter Channel Assignments

Channel Select Control Bits CD:CC:CB:CA	Channel Signal	Result in ADRx if MULT = 1
0000	AN0	ADR1
0001	AN1	ADR2
0010	AN2	ADR3
0011	AN3	ADR4
0100	AN4	ADR1
0101	AN5	ADR2
0110	AN6	ADR3
0111	AN7	ADR4
10XX	Reserved	ADR1–ADR4
1100	V_{RH}^1	ADR1
1101	V_{RL}^1	ADR2
1110	$(V_{RH})/2^1$	ADR3
1111	Reserved ¹	ADR4

NOTES:

- 1. Used for factory testing.

ADR1 – ADR4 — A/D Results

\$x031 – \$x034

\$x031	Bit 7	6	5	4	3	2	1	Bit 0	ADR1
\$x032	Bit 7	6	5	4	3	2	1	Bit 0	ADR2
\$x033	Bit 7	6	5	4	3	2	1	Bit 0	ADR3
\$x034	Bit 7	6	5	4	3	2	1	Bit 0	ADR4

Each read-only result register holds an eight-bit conversion result. Writes to these registers have no effect. Data in the A/D converter result registers is valid when the CCF flag in the ADCTL register is set, indicating a conversion sequence is complete. If conversion results are needed sooner, refer to **Figure 16**, which shows the A/D conversion sequence diagram.

Table 25 Analog Input to 8-Bit Result Translation Table

	Bit 7	6	5	4	3	2	1	Bit 0
Percentage ¹	50%	25%	12.5%	6.25%	3.12%	1.56%	0.78%	0.39%
Volts ²	2.500	1.250	0.625	0.3125	0.1562	0.0781	0.0391	0.0195

NOTES:

1. % of $V_{RH} - V_{RL}$
2. Volts for $V_{RL} = 0$; $V_{RH} = 5.0$ V

OPTION — System Configuration Options

\$x039

	Bit 7	6	5	4	3	2	1	Bit 0
	ADPU	CSEL	IRQE*	DLY*	CME	FCME*	CR1*	CR0*
RESET:	0	0	0	1	0	0	0	0

*Can be written only once in first 64 cycles out of reset in normal modes, or at any time in special modes.

ADPU — A/D Power Up

- 0 = A/D powered down
- 1 = A/D powered up

CSEL — Clock Select

- 0 = A/D and EEPROM use system E-Clock
- 1 = A/D and EEPROM use internal RC clock

Bits [5:0] — Refer to **4.3 System Initialization Registers**, page 23.

12 Main Timer

The main timer is based on a free-running 16-bit counter with a four-stage programmable prescaler. The timer drives the three input capture (IC) channels, four output compare (OC) channels, one channel programmable for either IC or OC, and the pulse accumulator (PA). All of these functions share port A. The main timer also drives the pulse accumulator, real-time interrupt (RTI), and computer operating properly (COP) watchdog circuits.

12.1 Timer Operation

The following tables summarize timing periods for various M68HC11 functions derived from the main timer for several crystal frequencies.

Table 26 Timer Subsystem Count and Overflow Periods

E-Clock Frequency	PR[1:0] = 00		PR[1:0] = 01		PR[1:0] = 10		PR[1:0] = 11	
	1 Count	TCNT Overflow	1 Count	TCNT Overflow	1 Count	TCNT Overflow	1 Count	TCNT Overflow
1 MHz	1.000 μ s	65.536 ms	4.000 μ s	262.144 ms	8.000 μ s	524.288 ms	16.000 μ s	1.049 s
2 MHz	0.500 μ s	32.768 ms	2.000 μ s	131.072 ms	4.000 μ s	262.144 ms	8.000 μ s	524.288 ms
3 MHz	0.333 μ s	21.845 ms	1.333 μ s	87.381 ms	2.667 μ s	174.763 ms	5.333 μ s	349.525 ms
4 MHz	0.250 μ s	16.384 ms	1.000 μ s	65.536 ms	2.000 μ s	131.072 ms	4.000 μ s	262.144 ms
5 MHz	0.200 μ s	13.107 ms	0.800 μ s	52.429 ms	1.600 μ s	104.858 ms	3.200 μ s	209.715 ms
6 MHz	0.167 μ s	10.923 ms	0.667 μ s	43.691 ms	1.333 μ s	87.381 ms	2.667 μ s	174.763 ms
Any E	1/E	$2^{16}/E$	4/E	$2^{18}/E$	8/E	$2^{19}/E$	16/E	$2^{20}/E$

Table 27 Real-Time Interrupt Periods

E-Clock Frequency	RTR[1:0] = 00	RTR[1:0] = 01	RTR[1:0] = 10	RTR[1:0] = 11
1 MHz	8.192 ms	16.384 ms	32.768 ms	65.536 ms
2 MHz	4.096 ms	8.192 ms	16.384 ms	32.768 ms
3 MHz	2.731 ms	5.461 ms	10.923 ms	21.845 ms
4 MHz	2.048 ms	4.096 ms	8.192 ms	16.384 ms
5 MHz	1.638 ms	3.277 ms	6.554 ms	13.107 ms
6 MHz	1.366 ms	2.731 ms	5.461 ms	10.923 ms
Any E	$2^{13}/E$	$2^{14}/E$	$2^{15}/E$	$2^{21}/E$

Table 28 COP Watchdog Time-Out Periods

E-Clock Frequency	RTR[1:0] = 00	RTR[1:0] = 01	RTR[1:0] = 10	RTR[1:0] = 11
1 MHz	32.768 ms	131.072 ms	524.288 ms	2.097 s
2 MHz	16.384 ms	65.536 ms	262.144 ms	1.049 s
3 MHz	10.923 ms	43.691 ms	174.763 ms	699.051 ms
4 MHz	8.192 ms	32.768 ms	131.072 ms	524.288 ms
5 MHz	6.554 ms	26.214 ms	104.858 ms	419.430 ms
6 MHz	5.461 ms	21.845 ms	87.381 ms	349.525 ms
Any E	$2^{15}/E$	$2^{17}/E$	$2^{19}/E$	$2^{21}/E$

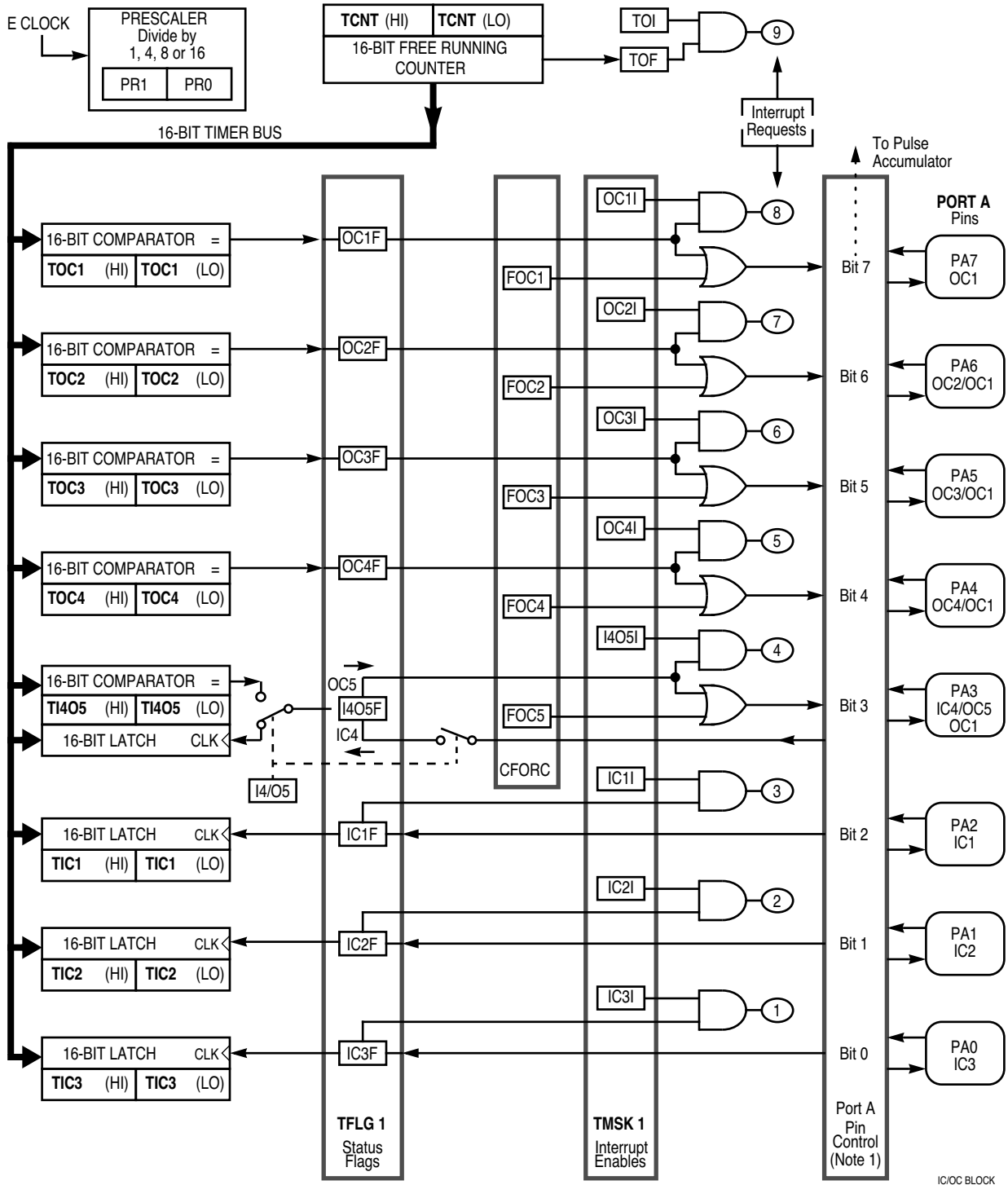

NOTE: Registers that control port A action include DDRA, OC1M, OC1D, PACTL, TCTL1 and TCTL2.

Figure 17 Main Timer

12.2 Timer Registers

CFORC — Timer Force Compare

\$x00B

	Bit 7	6	5	4	3	2	1	Bit 0
	FOC1	FOC2	FOC3	FOC4	FOC5	0	0	0
RESET:	0	0	0	0	0	0	0	0

FOCx — Force Output Compare x Action

0 = Not affected

1 = Output compare x action occurs, but OCxF flag bit is not set

Bits [2:0] — Not implemented. Reads always return zero and writes have no effect.

OC1M — Output Compare 1 Mask

\$x00C

	Bit 7	6	5	4	3	2	1	Bit 0
	OC1M7	OC1M6	OC1M5	OC1M4	OC1M3	0	0	0
RESET:	0	0	0	0	0	0	0	0

Bits set in OC1M allow OC1 to output the corresponding OC1D bits in port A when a successful compare event occurs.

OC1M[7:3] — Output Compare Masks

0 = Control of the corresponding port A pin is disabled

1 = Control of the corresponding port A pin is enabled

Bits [2:0] — Not implemented. Reads always return zero and writes have no effect.

OC1D — Output Compare 1 Data

\$x00D

	Bit 7	6	5	4	3	2	1	Bit 0
	OC1D7	OC1D6	OC1D5	OC1D4	OC1D3	0	0	0
RESET:	0	0	0	0	0	0	0	0

OC1D[7:3] — Output Compare Data

Data in OC1Dx is output to port A bit x on successful OC1 compares if OC1Mx is set.

Bits [2:0] — Not implemented. Reads always return zero and writes have no effect.

TCNT — Timer Count

\$x00E, \$x00F

\$x00E	Bit 15	14	13	12	11	10	9	Bit 8	High
\$x00F	Bit 7	6	5	4	3	2	1	Bit 0	Low
RESET:	0	0	0	0	0	0	0	0	

The 16-bit read-only TCNT register contains the prescaled value of the 16-bit timer. A full counter read addresses the most significant byte (MSB) first. A read of this address causes the least significant byte to be latched into a buffer for the next CPU cycle so that a double-byte read returns the full 16-bit state of the counter at the time of the MSB read cycle.

TIC1–TIC3 — Timer Input Capture

\$x010–\$x015

\$x010	Bit 15	14	13	12	11	10	9	Bit 8	High
\$x011	Bit 7	6	5	4	3	2	1	Bit 0	Low
\$x012	Bit 15	14	13	12	11	10	9	Bit 8	High
\$x013	Bit 7	6	5	4	3	2	1	Bit 0	Low
\$x014	Bit 15	14	13	12	11	10	9	Bit 8	High
\$x015	Bit 7	6	5	4	3	2	1	Bit 0	Low

TICx registers are not affected by reset.

TOC1–TOC4 — Timer Output Compare

\$x016–\$x01D

\$x016	Bit 15	14	13	12	11	10	9	Bit 8	High
\$x017	Bit 7	6	5	4	3	2	1	Bit 0	Low
\$x018	Bit 15	14	13	12	11	10	9	Bit 8	High
\$x019	Bit 7	6	5	4	3	2	1	Bit 0	Low
\$x01A	Bit 15	14	13	12	11	10	9	Bit 8	High
\$x01B	Bit 7	6	5	4	3	2	1	Bit 0	Low
\$x01C	Bit 15	14	13	12	11	10	9	Bit 8	High
\$x01D	Bit 7	6	5	4	3	2	1	Bit 0	Low

All TOCx register pairs are reset to ones (\$FFFF).

TI4/O5 — Timer Input Capture 4/Output Compare 5

\$x01E, \$x01F

\$x01E	Bit 15	14	13	12	11	10	9	Bit 8	High
\$x01F	Bit 7	6	5	4	3	2	1	Bit 0	Low

TI4/O5 is reset to ones (\$FFFF).

TCTL1 — Timer Control 1

\$x020

	Bit 7	6	5	4	3	2	1	Bit 0
	OM2	OL2	OM3	OL3	OM4	OL4	OM5	OL5
RESET:	0	0	0	0	0	0	0	0

OM2–OM5 — Output Mode

OL2–OL5 — Output Level

Each OMx–OLx bit pair determines the output action taken on the corresponding OCx pin after a successful compare, as shown in **Table 29**. OC5 functions only if the I4/O5 bit in the PACTL register is cleared.

Table 29 Output Compare Actions

OMx	OLx	Action Taken on Successful Compare
0	0	Timer disconnected from output pin logic
0	1	Toggle OCx output line
1	0	Clear OCx output line to zero
1	1	Set OCx output line to one

TCTL2 — Timer Control 2

\$x021

	Bit 7	6	5	4	3	2	1	Bit 0
	EDG4B	EDG4A	EDG1B	EDG1A	EDG2B	EDG2A	EDG3B	EDG3A
RESET:	0	0	0	0	0	0	0	0

EDGxB, EDGxA — Input Capture Edge Control

Each EDGxB, EDGxA pair determines the polarity of the input signal on the corresponding ICx that will trigger an input capture, as shown in **Table 30**. IC4 functions only if the I4/O5 bit in the PACTL register is set.

Table 30 Input Capture Configuration

EDGxB	EDGxA	Configuration
0	0	Capture disabled
0	1	Capture on rising edges only
1	0	Capture on falling edges only
1	1	Capture on any edge

TMSK1 — Timer Interrupt Mask 1

\$x022

	Bit 7	6	5	4	3	2	1	Bit 0
	OC1I	OC2I	OC3I	OC4I	I4/O5I	IC1I	IC2I	IC3I
RESET:	0	0	0	0	0	0	0	0

Bits in TMSK1 correspond bit for bit with flag bits in TFLG1. Each bit that is set in TMSK1 enables the corresponding interrupt source.

OCxI — Output Compare x Interrupt Enable

If the OCxI enable bit is set when the OCxF flag bit is set, a hardware interrupt sequence is requested.

I4/O5I — Input Capture 4/Output Compare 5 Interrupt Enable

When I4/O5 in PACTL is one, I4/O5I is the input capture 4 interrupt enable bit. When I4/O5 in PACTL is zero, I4/O5I is the output compare 5 interrupt enable bit.

ICxI — Input Capture x Interrupt Enable

If the ICxI enable bit is set when the ICxF flag bit is set, a hardware interrupt sequence is requested.

TFLG1 — Timer Interrupt Flag 1

\$x023

	Bit 7	6	5	4	3	2	1	Bit 0
	OC1F	OC2F	OC3F	OC4F	I4/O5F	IC1F	IC2F	IC3F
RESET:	0	0	0	0	0	0	0	0

Bits in TFLG1 are cleared by writing a one to the corresponding bit positions.

OCxF — Output Compare x Flag

Set each time the counter matches output compare x value.

I4/O5F — Input Capture 4/Output Compare 5 Flag

Set by IC4 or OC5, depending on which function was enabled by I4/O5 of PACTL.

ICxF — Input Capture x Flag

Set each time a selected active edge is detected on the ICx input line.

TMSK2 — Timer Interrupt Mask 2

\$x024

	Bit 7	6	5	4	3	2	1	Bit 0
	TOI	RTII	PAOVI	PAII	0	0	PR1	PR0
RESET:	0	0	0	0	0	0	0	0

Bits [7:4] in TMSK2 correspond bit for bit with flag bits in TFLG2. Setting any of these bits enables the corresponding interrupt source. TMSK2 can be written only once in the first 64 cycles out of reset in normal modes, or at any time in special modes.

TOI — Timer Overflow Interrupt Enable

- 0 = Timer overflow interrupt disabled
- 1 = Interrupt requested when TOF is set

RTII — Real-Time Interrupt Enable

- 0 = Real-time interrupt disabled
- 1 = Interrupt requested when RTIF is set

Bits [5:4] — See **13.2 Pulse Accumulator Registers**, page 64.

Bits [3:2] — Not implemented. Reads always return zero and writes have no effect.

PR[1:0] — Timer Prescaler Select

Determines the main timer prescale factor as shown in **Table 31**. See **Table 26** for specific frequencies.

Table 31 Main Timer Prescale Control

PR[1:0]	Prescaler
0 0	1
0 1	4
1 0	8
1 1	16

TFLG2 — Timer Interrupt Flag 2

\$x025

	Bit 7	6	5	4	3	2	1	Bit 0
	TOF	RTIF	PAOVF	PAIF	0	0	0	0
RESET:	0	0	0	0	0	0	0	0

Bits in this register indicate when certain timer system events have occurred. Coupled with the four high-order bits of TMSK2, the bits of TFLG2 allow the timer subsystem to operate in either a polled or interrupt driven system. Each bit of TFLG2 corresponds to a bit in TMSK2 in the same position.

Bits in TFLG2 are cleared by writing a one to the corresponding bit positions.

TOF — Timer Overflow Flag

Set when TCNT rolls over from \$FFFF to \$0000.

RTIF — Real-Time Interrupt Flag

Set periodically at a rate based on bits RTR[1:0] in the PACTL register.

Bits [5:4] — See **13.2 Pulse Accumulator Registers**, page 65.

Bits [3:0] — Not implemented. Reads always return zero and writes have no effect.

PACTL — Pulse Accumulator Control

\$x026

	Bit 7	6	5	4	3	2	1	Bit 0
	0	PAEN	PAMOD	PEDGE	0	I4/O5	RTR1	RTR0
RESET:	0	0	0	0	0	0	0	0

Bit 7 — Not implemented. Reads always return zero and writes have no effect.

Bits [6:4] — See **13.2 Pulse Accumulator Registers**, page 65.

Bit 3 — Not implemented. Reads always return zero and writes have no effect.

I4/O5 — Configure TI4/O5 Register for IC or OC

0 = OC5 function enabled

1 = IC4 function enabled

RTR[1:0] — RTI Interrupt Rate Selects

These two bits select one of four rates for the real-time interrupt circuit, as shown in **Table 32**.

Table 32 Real-Time Interrupt Periods

E-Clock Frequency	RTR [1:0] = %00	RTR [1:0] = 01	RTR [1:0] = 10	RTR [1:0] = 11
1 MHz	8.192 ms	16.384 ms	32.768 ms	65.536 ms
2 MHz	4.906 ms	8.192 ms	16.384 ms	32.768 ms
3 MHz	2.731 ms	5.461 ms	10.923 ms	21.845 ms
4 MHz	2.048 ms	4.096 ms	8.192 ms	16.384 ms
5 MHz	1.638 ms	3.277 ms	6.554 ms	13.107 ms
6 MHz	1.366 ms	2.731 ms	5.461 ms	10.923 ms
Any E	$2^{13}/E$	$2^{14}/E$	$2^{15}/E$	$2^{16}/E$

13 Pulse Accumulator

The pulse accumulator can be used either to count events or measure the duration of a particular event. In event counting mode, the pulse accumulator's 8-bit counter increments each time a specified edge is detected on the pulse accumulator input pin, PA7. The maximum clocking rate for this mode is the E-clock divided by two. In gated time accumulation mode, an internal clock increments the 8-bit counter at a rate of E-clock ÷ 64 while the input at PA7 remains at a predetermined logic level.

13.1 Pulse Accumulator Block Diagram

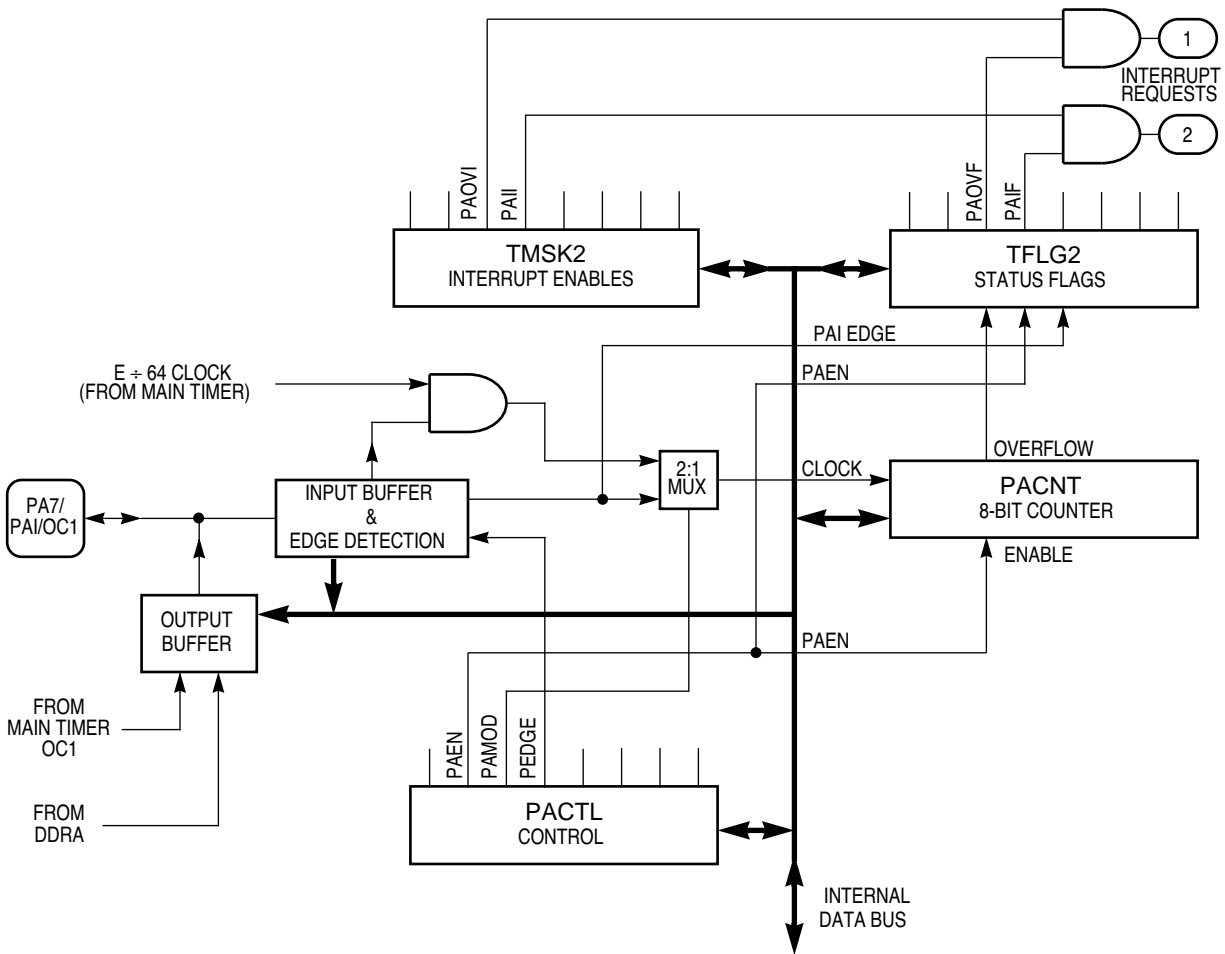

Figure 18 Pulse Accumulator Block Diagram

13.2 Pulse Accumulator Registers

TMSK2 — Timer Interrupt Mask 2

\$x024

	Bit 7	6	5	4	3	2	1	Bit 0
	TOI	RTII	PAOVI	PAII	0	0	PR1	PR0
RESET:	0	0	0	0	0	0	0	0

Bits [7:4] in TMSK2 correspond bit for bit with flag bits in TFLG2. Setting any of these bits enables the corresponding interrupt source.

Bits[7:6] — See **12.2 Timer Registers**, page 62.

PAOVI — Pulse Accumulator Overflow Interrupt Enable
 0 = Pulse accumulator overflow interrupt disabled
 1 = Interrupt requested when PAOVF in TFLG2 is set

PAII — Pulse Accumulator Interrupt Enable
 0 = Pulse accumulator interrupt disabled
 1 = Interrupt requested when PAIF in TFLG2 is set

Bits [3:2] — Not implemented. Reads always return zero and writes have no effect.

Bits [1:0] — See **12.2 Timer Registers**, page 62.

TFLG2 — Timer Interrupt Flag 2

\$x025

	Bit 7	6	5	4	3	2	1	Bit 0
	TOF	RTIF	PAOVF	PAIF	0	0	0	0
RESET:	0	0	0	0	0	0	0	0

Bits in TFLG2 are cleared by writing a one to the corresponding bit positions.

Bits [7:6] — See **12.2 Timer Registers**, page 62.

PAOVF — Pulse Accumulator Overflow Flag
 Set when PACNT rolls over from \$FF to \$00

PAIF — Pulse Accumulator Input Edge Flag
 Set each time a selected active edge is detected on the PAI input line

Bits [3:0] — Not implemented. Reads always return zero and writes have no effect.

PACTL — Pulse Accumulator Control

\$x026

	Bit 7	6	5	4	3	2	1	Bit 0
	0	PAEN	PAMOD	PEDGE	0	I4/O5	RTR1	RTR0
RESET:	0	0	0	0	0	0	0	0

Bit 7 — Not implemented. Reads always return zero and writes have no effect.

PAEN — Pulse Accumulator System Enable
 0 = Pulse accumulator disabled
 1 = Pulse accumulator enabled

PAMOD — Pulse Accumulator Mode
 0 = Event counter
 1 = Gated time accumulation

PEDGE — Pulse Accumulator Edge Control
 This bit has different meanings depending on the state of the PAMOD bit, as shown in **Table 33**.

Table 33 Pulse Accumulator Edge Control

PAMOD	PEDGE	Action on Clock
0	0	PAI falling edge increments the counter.
0	1	PAI rising edge increments the counter.
1	0	A zero on PAI inhibits counting.
1	1	A one on PAI inhibits counting.

Bit 3 — Not implemented. Reads always return zero and writes have no effect.

Bits [2:0] — See **12.2 Timer Registers**, page 63.

PACNT — Pulse Accumulator Count

\$x027

	Bit 7	6	5	4	3	2	1	Bit 0
	Bit 7	6	5	4	3	2	1	Bit 0
RESET:	U	U	U	U	U	U	U	U

U = Unaffected by reset

This eight-bit read/write register contains the count of external input events at the PAI input, or the accumulated count. The PACNT is readable even if PAI is not active in gated time accumulation mode. The counter is not affected by reset and can be read or written at any time. Counting is synchronized to the internal PH2 clock so that incrementing and reading occur during opposite half cycles.

Freescale Semiconductor, Inc.

Home Page:

www.freescale.com

email:

support@freescale.com

USA/Europe or Locations Not Listed:

Freescale Semiconductor
Technical Information Center, CH370
1300 N. Alma School Road
Chandler, Arizona 85224
(800) 521-6274
480-768-2130

support@freescale.com

Europe, Middle East, and Africa:

Freescale Halbleiter Deutschland GmbH
Technical Information Center
Schatzbogen 7
81829 Muenchen, Germany
+44 1296 380 456 (English)
+46 8 52200080 (English)
+49 89 92103 559 (German)
+33 1 69 35 48 48 (French)
support@freescale.com

Japan:

Freescale Semiconductor Japan Ltd.
Headquarters
ARCO Tower 15F
1-8-1, Shimo-Meguro, Meguro-ku
Tokyo 153-0064, Japan
0120 191014
+81 2666 8080
support.japan@freescale.com

Asia/Pacific:

Freescale Semiconductor Hong Kong Ltd.
Technical Information Center
2 Dai King Street
Tai Po Industrial Estate,
Tai Po, N.T., Hong Kong
+800 2666 8080
support.asia@freescale.com

For Literature Requests Only:

Freescale Semiconductor
Literature Distribution Center
P.O. Box 5405
Denver, Colorado 80217
(800) 441-2447
303-675-2140
Fax: 303-675-2150
LDCForFreescaleSemiconductor@hibbertgroup.com

RoHS-compliant and/or Pb- free versions of Freescale products have the functionality and electrical characteristics of their non-RoHS-compliant and/or non-Pb- free counterparts. For further information, see <http://www.freescale.com> or contact your Freescale sales representative.

For information on Freescale's Environmental Products program, go to <http://www.freescale.com/epp>.

Information in this document is provided solely to enable system and software implementers to use Freescale Semiconductor products. There are no express or implied copyright licenses granted hereunder to design or fabricate any integrated circuits or integrated circuits based on the information in this document. Freescale Semiconductor reserves the right to make changes without further notice to any products herein. Freescale Semiconductor makes no warranty, representation or guarantee regarding the suitability of its products for any particular purpose, nor does Freescale Semiconductor assume any liability arising out of the application or use of any product or circuit, and specifically disclaims any and all liability, including without limitation consequential or incidental damages. "Typical" parameters which may be provided in Freescale Semiconductor data sheets and/or specifications can and do vary in different applications and actual performance may vary over time. All operating parameters, including "Typicals" must be validated for each customer application by customer's technical experts. Freescale Semiconductor does not convey any license under its patent rights nor the rights of others. Freescale Semiconductor products are not designed, intended, or authorized for use as components in systems intended for surgical implant into the body, or other applications intended to support or sustain life, or for any other application in which the failure of the Freescale Semiconductor product could create a situation where personal injury or death may occur. Should Buyer purchase or use Freescale Semiconductor products for any such unintended or unauthorized application, Buyer shall indemnify and hold Freescale Semiconductor and its officers, employees, subsidiaries, affiliates, and distributors harmless against all claims, costs, damages, and expenses, and reasonable attorney fees arising out of, directly or indirectly, any claim of personal injury or death associated with such unintended or unauthorized use, even if such claim alleges that Freescale Semiconductor was negligent regarding the design or manufacture of the part.



**For More Information On This Product,
Go to: www.freescale.com**