

National Semiconductor is now part of
Texas Instruments.

Search <http://www.ti.com/> for the latest technical
information and details on our current products and services.

LM4844 Boomer[®] Audio Power Amplifier Series

Stereo 1.2W Audio Sub-System with 3D Enhancement

General Description

The LM4844 is an integrated audio sub-system designed for stereo cell phone applications. Operating on a 3.3V supply, it combines a stereo speaker amplifier delivering 495mW per channel into an 8 Ω load and a stereo OCL headphone amplifier delivering 33mW per channel into a 32 Ω load.

It integrates the audio amplifiers, volume control, mixer, power management control, and National 3D enhancement all into a single package. In addition, the LM4844 routes and mixes the stereo and mono inputs into 10 distinct output modes. The LM4844 is controlled through an I²C compatible interface.

Boomer audio power amplifiers are designed specifically to provide high quality output power with a minimal amount of external components.

The LM4844 is available in a very small 2.5mm x 2.9mm 30-bump micro SMD (TL) package.

Key Specifications

- | | |
|---|-------------------|
| ■ P _{OUT} , Stereo BTL, 8 Ω , 3.3V,
1% THD+N | 495mW (typ) |
| ■ P _{OUT} HP, 32 Ω , 3.3V,
1% THD+N | 33mW (typ) |
| ■ Shutdown Current, 3.3V | 0.1 μ A (typ) |

Features

- Stereo speaker amplifier
- Stereo OCL headphone amplifier
- Independent Left, Right, and Mono volume controls
- National 3D enhancement
- I²C compatible interface
- Ultra low shutdown current
- Click and Pop Suppression circuit
- 10 distinct output modes

Applications

- Cell Phones
- PDAs
- Portable Gaming Devices
- Internet Appliances
- Portable DVD, CD, AAC, and MP3 Players

Block Diagram

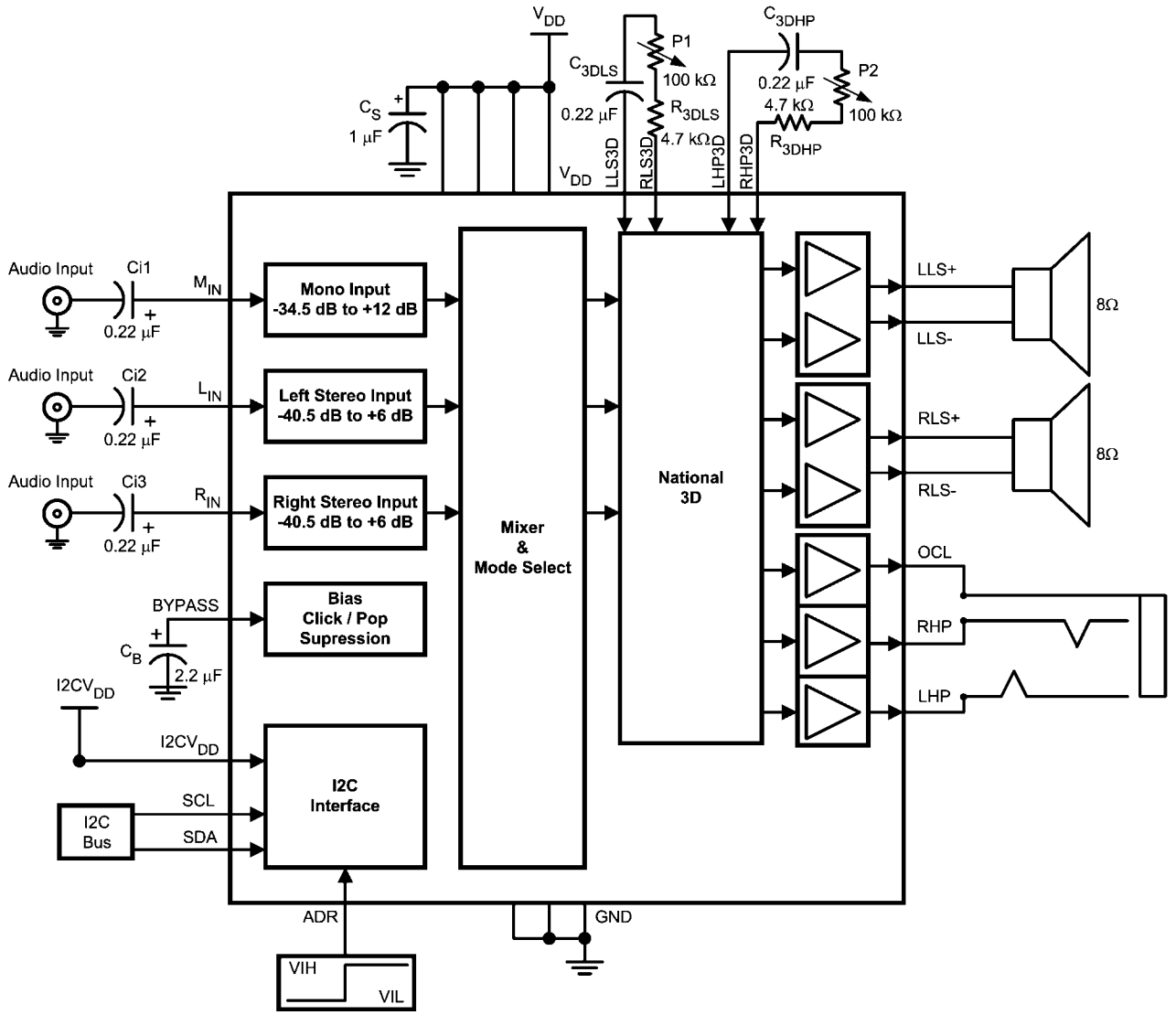
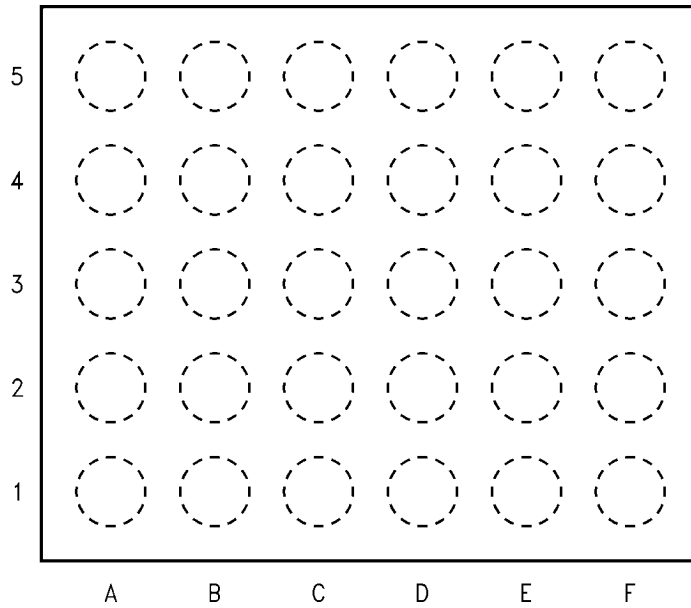

FIGURE 1. Audio Sub-System Block Diagram

20153531

Connection Diagrams

30 Bump Micro SMD (TL) Package



20153508

Top View
(Bump-side down)
Order Number LM4844TL
See NS Package Number TLA30CZA

Micro SMD (TL) Marking

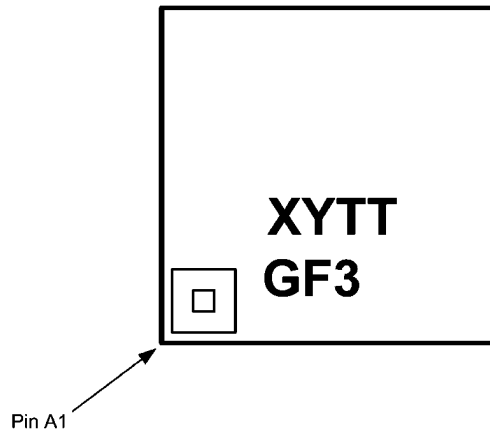

20153592

Top View
XY = 2 Digit Date Code
TT = Die Traceability
G = Boomer Family
F3 = LM4844TL

Pin Connection (TL)

Pin	Name	Pin Description
A1	RLS+	Right Loudspeaker Positive Output
A2	V _{DD}	Power Supply
A3	SDA	Data
A4	RHP3D	Right Headphone 3D
A5	RHP	Right Headphone Output
B1	GND	Ground
B2	I ² C V _{DD}	I ² C Interface Power Supply
B3	ADR	I ² C Address Select
B4	LHP3D	Left Headphone 3D
B5	V _{DD}	Power Supply
C1	RLS-	Right Loudspeaker Negative Output
C2	NC	No Connect
C3	SCL	Clock
C4	NC	No Connect
C5	GND	Ground
D1	LLS-	Left Loudspeaker Negative Output
D2	V _{DD}	Power Supply
D3	M _{IN}	Mono Input
D4	NC	No Connect
D5	OCL	V _{DD} /2 Supply for headphone jack's sleeve
E1	GND	Ground
E2	BYPASS	Half-supply bypass
E3	LLS3D	Left Loudspeaker 3D
E4	R _{IN}	Right Stereo Input
E5	NC	No Connect
F1	LLS+	Left Loudspeaker Positive Output
F2	V _{DD}	Power Supply
F3	RLS3D	Right Loudspeaker 3D
F4	L _{IN}	Left Stereo Input
F5	LHP	Left Headphone Output

Absolute Maximum Ratings (Notes 1, 2)

If Military/Aerospace specified devices are required, please contact the National Semiconductor Sales Office/Distributors for availability and specifications.

Supply Voltage	6.0V
Storage Temperature	-65°C to +150°C
Input Voltage	-0.3V to $V_{DD} + 0.3V$
Power Dissipation (Note 3)	Internally Limited
ESD Susceptibility (Note 4)	2000V
ESD Susceptibility (Note 5)	200V
Junction Temperature (T_J)	150°C

Thermal Resistance

 θ_{JA} (TLA30CZA)

62°C/W

Operating Ratings

Temperature Range

 $T_{MIN} \leq T_A \leq T_{MAX}$ $-40^\circ\text{C} \leq T_A \leq +85^\circ\text{C}$ Supply Voltage (V_{DD}) $2.7V \leq V_{DD} \leq 5.5V$ Supply Voltage (I^2CV_{DD}) (Note 10) $I^2CV_{DD} \leq V_{DD}$ $1.7V \leq I^2CV_{DD} \leq 5.5V$ **Audio Amplifier Electrical Characteristics** $V_{DD} = 5.0V$ (Notes 1, 2)

The following specifications apply for $V_{DD} = 5.0V$, unless otherwise specified. Limits apply for $T_A = 25^\circ\text{C}$.

Symbol	Parameter	Conditions	LM4844		Units (Limits)
			Typical (Note 6)	Limits (Notes 7, 8)	
I_{DD}	Supply Current	$V_{IN} = 0V$, No load; LD5 = RD5 = 0			
		Mode 4, 9, 14	5	8	mA (max)
		Mode 2, 7, 12	12	18	mA (max)
		Mode 3, 8, 13	13	20	mA (max)
I_{SD}	Shutdown Current	Mode 0	0.2	2.5	μA (max)
P_O	Output Power	Speaker; THD+N = 1%; f = 1kHz; 8 Ω BTL	1.2	0.9	W (min)
		Headphone; THD+N = 1%; f = 1kHz; 32 Ω SE	80	60	mW (min)
THD+N	Total Harmonic Distortion Plus Noise	LD5 = RD5 = 0			
		Speaker; $P_O = 400\text{mW}$; f = 1kHz; 8 Ω BTL	0.05		%
		Headphone; $P_O = 15\text{mW}$; f = 1kHz; 32 Ω SE	0.06		%
V_{OS}	Offset Voltage	Speaker; LD5 = RD5 = 0	5	40	mV (max)
		Headphone; LD5 = RD5 = 0	2	30	mV (max)
N_{OUT}	Output Noise	A-weighted, 0dB gain; LD5 = RD5 = 0			
		Speaker; Mode 2, 3, 7, 8	31		μV
		Speaker; Mode 12, 13	35		μV
		Headphone; Mode 3, 4, 8, 9	12		μV
		Headphone; Mode 13, 14	14		μV
PSRR	Power Supply Rejection Ratio	f = 217Hz; $V_{rip} = 200\text{mV}_{pp}$; $C_B = 2.2\mu\text{F}$; 0dB Gain Setting; LD5 = RD5 = 0			
		Speaker; Mode 2, 3, 7, 8	71		dB
		Speaker; Mode 12, 13,	65	55	dB (min)
		Headphone; Mode 3, 4, 8, 9	76		dB
		Headphone; Mode 13, 14	72	62	dB (min)
Xtalk	Crosstalk	LD5 = RD5 = 0			
		Loudspeaker; $P_O = 400\text{mW}$; f = 1kHz	84		dB
		Headphone; $P_O = 15\text{mW}$; f = 1kHz	60		dB
T_{WU}	Wake-up Time	CD4 = 0; $C_B = 2.2\mu\text{F}$	103		ms
		CD4 = 1; $C_B = 2.2\mu\text{F}$	42		ms

Audio Amplifier Electrical Characteristics $V_{DD} = 3.0V$ (Notes 1, 2)

The following specifications apply for $V_{DD} = 3.0V$, unless otherwise specified. Limits apply for $T_A = 25^\circ C$.

Symbol	Parameter	Conditions	LM4844		Units (Limits)
			Typical (Note 6)	Limits (Notes 7, 8)	
I_{DD}	Supply Current	$V_{IN} = 0V$, No load; LD5 = RD5 = 0			
		Mode 4, 9, 14	4.5	7.5	mA (max)
		Mode 2, 7, 12	10	16	mA (max)
		Mode 3, 8, 13	11	18	mA (max)
I_{SD}	Shutdown Current	Mode 0	0.1	2	μA (max)
P_O	Output Power	Speaker; THD+N = 1%; $f = 1kHz$; 4 Ω BTL	390	320	mW (min)
		Headphone; THD+N = 1%; $f = 1kHz$; 32 Ω SE	28	21	mW (min)
THD+N	Total Harmonic Distortion Plus Noise	LD5 = RD5 = 0			
		Speaker; $P_O = 200mW$; $f = 1kHz$; 8 Ω BTL	0.05		%
		Headphone; $P_O = 10mW$; $f = 1kHz$; 32 Ω SE	0.05		%
V_{OS}	Offset Voltage	Speaker; LD5 = RD5 = 0	5	40	mV (max)
		Headphone; LD5 = RD5 = 0	2	30	mV (max)
N_{OUT}	Output Noise	A-weighted; 0dB gain; LD5 = RD5 = 0			
		Speaker; Mode 2, 3, 7, 8	32		μV
		Speaker; Mode 12, 13	41		μV
		Headphone; Mode 3, 4, 8, 9	13		μV
		Headphone; Mode 13, 14	15		μV
PSRR	Power Supply Rejection Ratio	$f = 217Hz$, $V_{rip} = 200mV_{pp}$; $C_B = 2.2\mu F$; 0dB Gain Setting; LD5 = RD5 = 0			
		Speaker; Mode 2, 3, 7, 8	73		dB
		Speaker; Mode 12, 13,	66	55	dB (min)
		Headphone; Mode 3, 4, 8, 9	78		dB
		Headphone; Mode 13, 14	72	62	dB (min)
Xtalk	Crosstalk	LD5 = RD5 = 0			
		Loudspeaker; $P_O = 200mW$; $f = 1kHz$	85		dB
		Headphone; $P_O = 10mW$; $f = 1kHz$	60		dB
T_{WU}	Wake-up Time	CD4 = 0; $C_B = 2.2\mu F$	70		ms
		CD4 = 1; $C_B = 2.2\mu F$	30		ms

Volume Control Electrical Characteristics (Notes 1, 2)

The following specifications apply for $3V \leq V_{DD} \leq 5V$ and $3V \leq I^2CV_{DD} \leq 5V$, unless otherwise specified. Limits apply for $T_A = 25^\circ C$.

Symbol	Parameter	Conditions	LM4844		Units (Limits)
			Typical (Note 6)	Limits (Notes 7, 8)	
	Stereo Volume Control Range	maximum gain setting	6	5.5 6.5	dB (min) dB (max)
		minimum gain setting	-40.5	-41 -40	dB (min) dB (max)
	Mono Volume Control Range	maximum gain setting	12	11.5 12.5	dB (min) dB (max)
		minimum gain setting	-34.5	-35 -34	dB (min) dB (max)
	Volume Control Step Size		1.5		dB
	Volume Control Step Size Error		+/-0.2	+/-0.5	dB (max)
	Stereo Channel to Channel Gain Mismatch		0.3		dB
	Mute Attenuation	Mode 12, $V_{in} = 1V_{RMS}$			
		Headphone	100		dB
	L_{IN} and R_{IN} Input Impedance	maximum gain setting	33	25 42	k Ω (min) k Ω (max)
		minimum gain setting	100	75 125	k Ω (min) k Ω (max)
	M_{IN} Input Impedance	maximum gain setting	20	15 25	k Ω (min) k Ω (max)
		minimum gain setting	96	73 123	k Ω (min) k Ω (max)

Control Interface Electrical Characteristics (Notes 1, 2)

The following specifications apply for $V_{DD} = 5.0V$ and $3.0V$, $T_A = 25^\circ C$, $2.2V \leq I^2CV_{DD} \leq 5.5V$, unless otherwise specified.

Symbol	Parameter	Conditions	LM4844		Units (Limits)
			Typical (Note 6)	Limits (Notes 1, 7, 8)	
t_1	I ² C Clock Period			2.5	μs (min)
t_2	I ² C Data Setup Time			100	ns (min)
t_3	I ² C Data Stable Time			0	ns (min)
t_4	Start Condition Time			100	ns (min)
t_5	Stop Condition time			100	ns (min)
t_6	I ² C Data Hold Time			100	ns (min)
V_{IH}	I ² C Input Voltage High			$0.7 \times I^2CV_{DD}$	V (min)
V_{IL}	I ² C Input Voltage Low			$0.3 \times I^2CV_{DD}$	V (max)

Control Interface Electrical Characteristics (Notes 1, 2)

The following specifications apply for $V_{DD} = 5.0V$ and $3.0V$, $T_A = 25^\circ C$, $1.7V \leq I^2CV_{DD} \leq 2.2V$, unless otherwise specified.

Symbol	Parameter	Conditions	LM4844		Units (Limits)
			Typical (Note 6)	Limits (Notes 1, 7, 8)	
t_1	I ² C Clock Period			2.5	μs (min)
t_2	I ² C Data Setup Time			250	ns (min)
t_3	I ² C Data Stable Time			0	ns (min)

Symbol	Parameter	Conditions	LM4844		Units (Limits)
			Typical (Note 6)	Limits (Notes 1, 7, 8)	
t_4	Start Condition Time			250	ns (min)
t_5	Stop Condition time			250	ns (min)
t_6	I ² C Data Hold Time			250	ns (min)
V_{IH}	I ² C Input Voltage High			$0.7 \times I^2CV_{DD}$	V (min)
V_{IL}	I ² C Input Voltage Low			$0.25 \times I^2CV_{DD}$	V (max)

Note 1: All voltages are measured with respect to the GND pin unless otherwise specified.

Note 2: Absolute Maximum Ratings indicate limits beyond which damage to the device may occur. Operating Ratings indicate conditions for which the device is functional but do not guarantee specific performance limits. Electrical Characteristics state DC and AC electrical specifications under particular test conditions which guarantee specific performance limits. This assumes that the device is within the Operating Ratings. Specifications are not guaranteed for parameters where no limit is given, however, the typical value is a good indication of device performance.

Note 3: The maximum power dissipation must be derated at elevated temperatures and is dictated by T_{JMAX} , θ_{JA} , and the ambient temperature, T_A . The maximum allowable power dissipation is $P_{DMAX} = (T_{JMAX} - T_A) / \theta_{JA}$ or the number given in Absolute Maximum Ratings, whichever is lower. For the LM4844 typical application with $V_{DD} = 3.3V$ and $R_L = 8\Omega$ stereo operation, the total power dissipation is TBDW. $\theta_{JA} = TBD^\circ C/W$.

Note 4: Human body model, 100pF discharged through a 1.5k Ω resistor.

Note 5: Machine Model, 220pF-240pF discharged through all pins.

Note 6: Typicals are measured at +25°C and represent the parametric norm.

Note 7: Limits are guaranteed to National's AOQL (Average Outgoing Quality Level).

Note 8: Datasheet min/max specification limits are guaranteed by design, test, or statistical analysis.

Note 9: Shutdown current and supply current are measured in a normal room environment.

Note 10: Refer to Control Interface Electrical Characteristics tables on page 6.

Typical Performance Characteristics

LM4844TL THD+N vs Frequency

$V_{DD} = 5V$, $R_L = 8\Omega$, Mode 7
 LS , $P_O = 400mW$

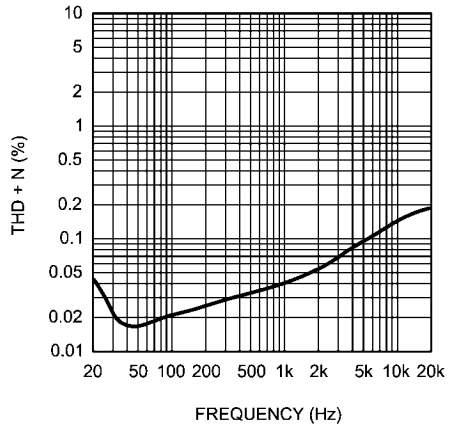

20153563

LM4844TL THD+N vs Frequency

$V_{DD} = 3V$, $R_L = 8\Omega$, Mode 7
 LS , $P_O = 200mW$

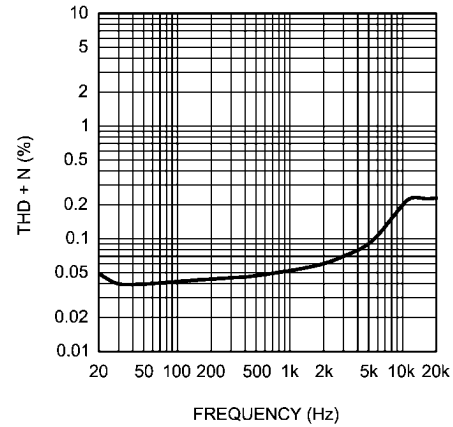

20153564

LM4844TL THD+N vs Frequency

$V_{DD} = 5V$, $R_L = 32\Omega$, Mode 9
 HP , $P_O = 15mW$, 0dB Gain

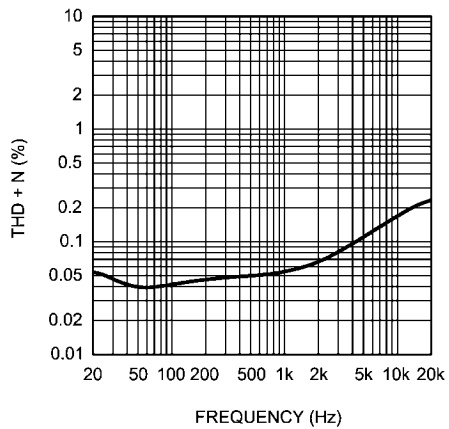

20153567

LM4844TL THD+N vs Frequency

$V_{DD} = 3V$, $R_L = 32\Omega$, Mode 9
 HP , $P_O = 10mW$, 0dB Gain

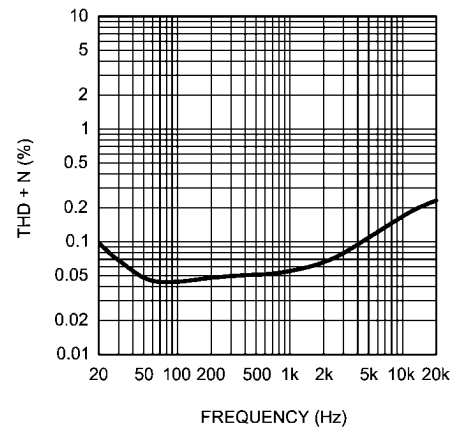

20153568

LM4844TL THD+N vs Output Power

$V_{DD} = 5V$, $R_L = 8\Omega$, Mode 7
 LS , $f = 1kHz$, 0dB Gain

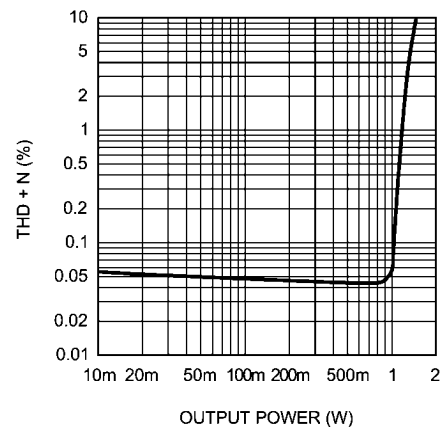

20153565

LM4844TL THD+N vs Output Power

$V_{DD} = 3V$, $R_L = 8\Omega$, Mode 7
 LS , $f = 1kHz$, 0dB Gain

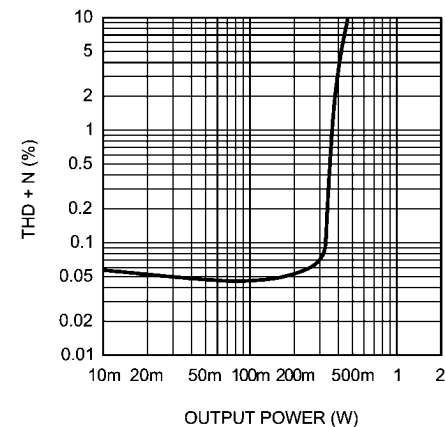

20153566

LM4844TL THD+N vs Output Power
 $V_{DD} = 5V, R_L = 32\Omega, \text{ Mode 9}$
 HP, $f = 1\text{kHz}, 0\text{dB Gain}$

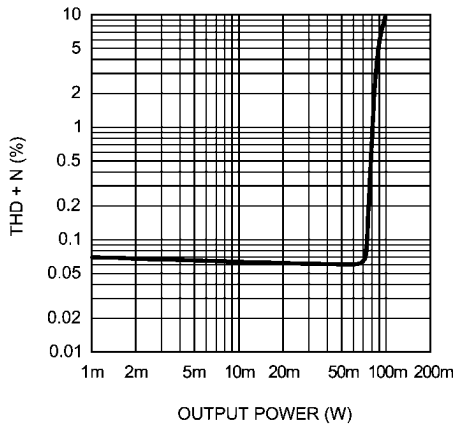

20153569

LM4844TL THD+N vs Output Power
 $V_{DD} = 3V, R_L = 32\Omega, \text{ Mode 9}$
 HP, $f = 1\text{kHz}, 0\text{dB Gain}$

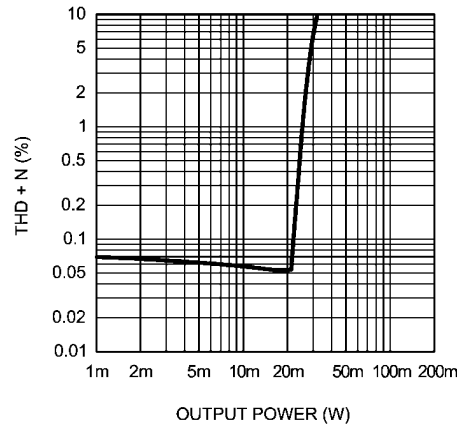

20153570

LM4844TL PSRR vs Frequency
 $V_{DD} = 5V, R_L = 8\Omega, \text{ LS}$
 Top-Modes 12, 13
 Bottom-Modes 2, 3, 7, 8

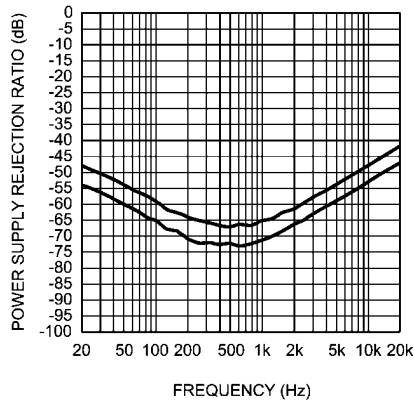

20153571

LM4844TL PSRR vs Frequency
 $V_{DD} = 3V, R_L = 8\Omega, \text{ LS}$
 Top-Modes 12, 13
 Bottom-Modes 2, 3, 7, 8

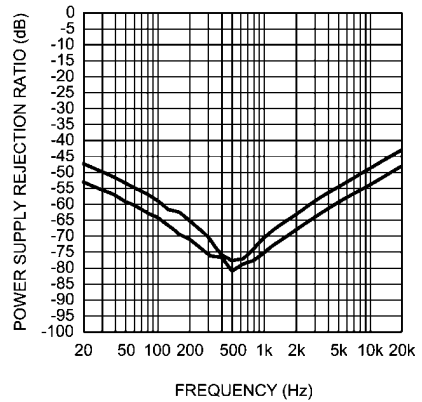

20153572

LM4844TL PSRR vs Frequency
 $V_{DD} = 5V, R_L = 32\Omega, \text{ HP}$
 Top-Modes 13, 14
 Bottom-Modes 3, 4, 8, 9

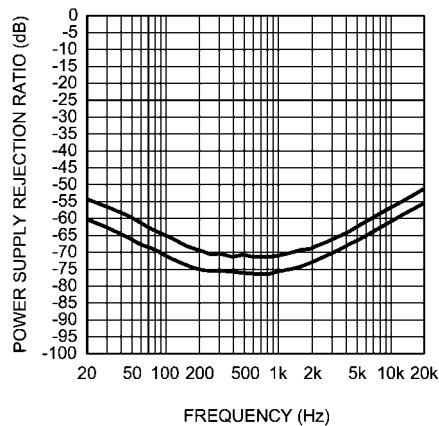

20153573

LM4844TL PSRR vs Frequency
 $V_{DD} = 3V, R_L = 32\Omega, \text{ HP}$
 Top-Modes 13, 14
 Bottom-Modes 3, 4, 8, 9

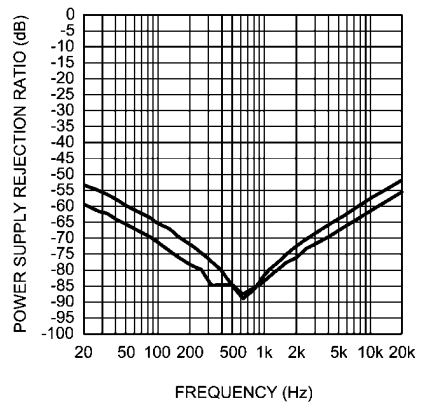

20153574

LM4844TL Crosstalk vs Frequency
 $V_{DD} = 5V, R_L = 8\Omega, \text{ Mode 7}$
 $LS, P_O = 400mW$

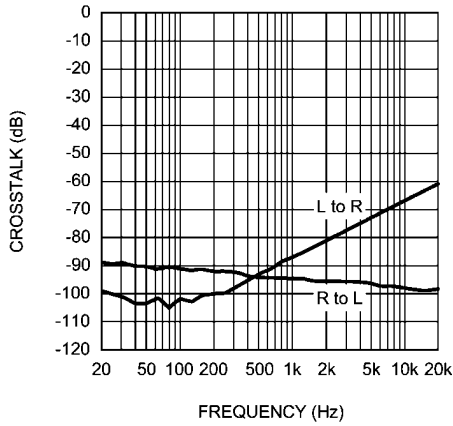

20153575

LM4844TL Crosstalk vs Frequency
 $V_{DD} = 3V, R_L = 8\Omega, \text{ Mode 7}$
 $LS, P_O = 200mW$

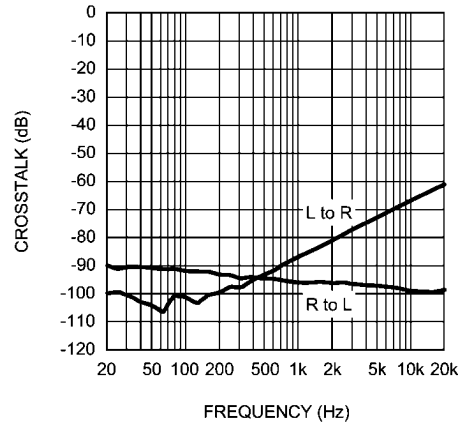

20153576

LM4844TL Crosstalk vs Frequency
 $V_{DD} = 5V, R_L = 32\Omega, \text{ Mode 9}$
 $HP, P_O = 15mW, 0dB \text{ Gain}$

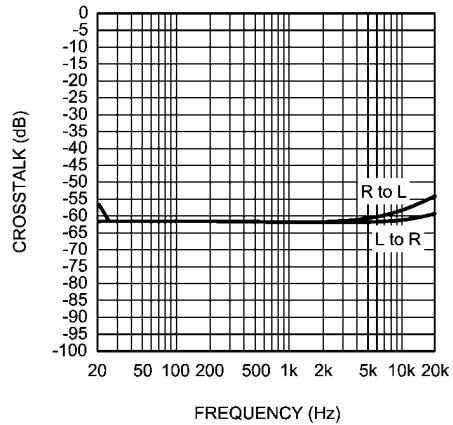

20153577

LM4844TL Crosstalk vs Frequency
 $V_{DD} = 3V, R_L = 32\Omega, \text{ Mode 9}$
 $HP, P_O = 10mW, 0dB \text{ Gain}$

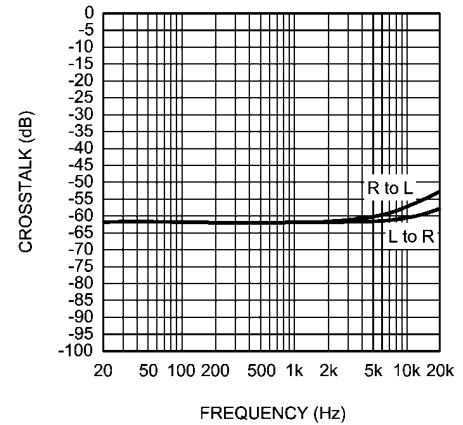

20153578

LM4844TL Frequency Response
 $V_{DD} = 5V, R_L = 8\Omega, \text{ Mode 2}$
 $LS, \text{ Full Gain} = 18dB$

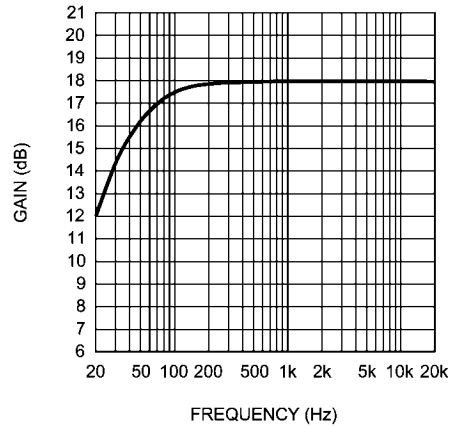

20153579

LM4844TL Frequency Response
 $V_{DD} = 5V, R_L = 8\Omega, \text{ Mode 7}$
 $LS, \text{ Full Gain} = 12dB$

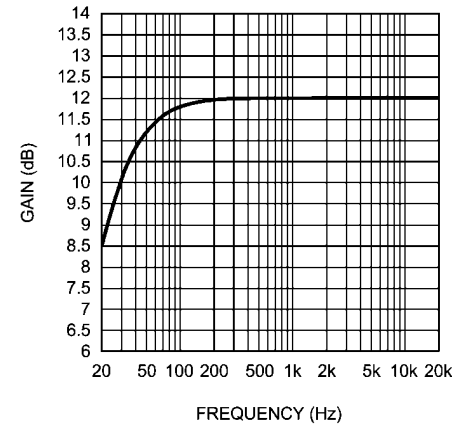

20153580

LM4844TL Frequency Response
 $V_{DD} = 5V, R_L = 32\Omega$, Mode 4
 HP, Full Gain = 12dB

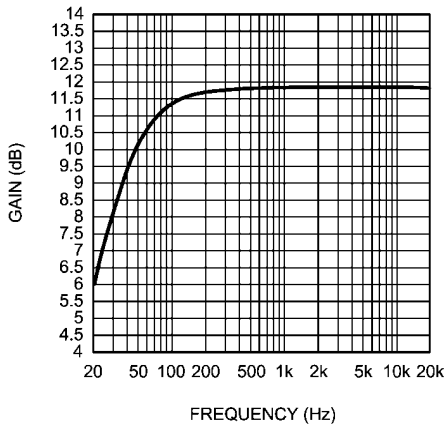

20153581

LM4844TL Frequency Response
 $V_{DD} = 5V, R_L = 32\Omega$, Mode 9
 HP, Full Gain = 6dB

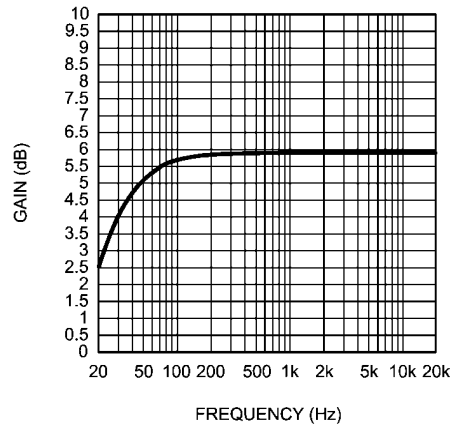

20153582

LM4844TL Power Dissipation vs Output Power
 $V_{DD} = 5V, R_L = 8\Omega$
 LS, per channel

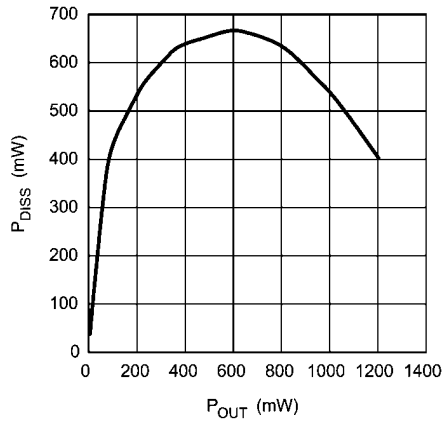

20153583

LM4844TL Power Dissipation vs Output Power
 $V_{DD} = 3V, R_L = 8\Omega$
 LS, per channel

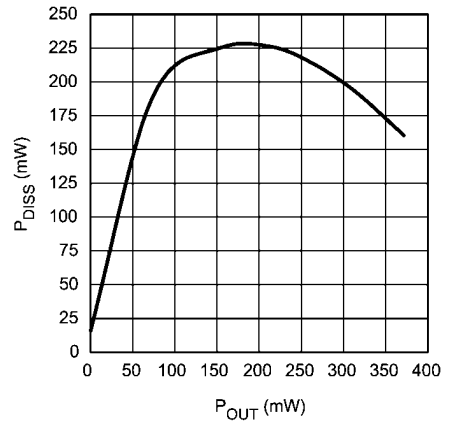

20153584

LM4844TL Power Dissipation vs Output Power
 $V_{DD} = 5V, R_L = 8\Omega$
 OCL HP, per channel

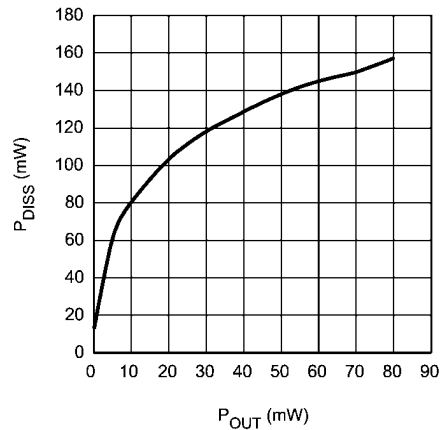

20153585

LM4844TL Power Dissipation vs Output Power
 $V_{DD} = 3V, R_L = 32\Omega$
 OCL HP, per channel

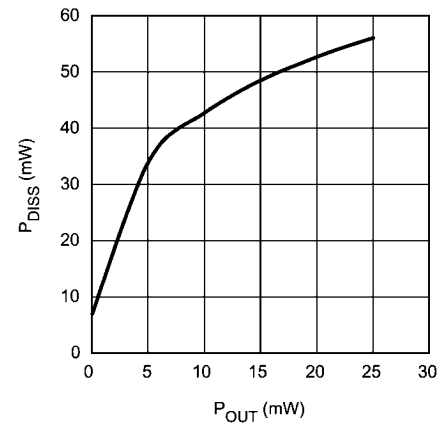

20153586

LM4844TL Output Power vs Load Resistance, LS
 Top- $V_{DD} = 5V, 10\% THD+N$; Topmid- $V_{DD} = 5V, 1\% THD+N$
 Botmid- $V_{DD} = 3V, 10\% THD+N$;
 Bot- $V_{DD} = 3V, 1\% THD+N$

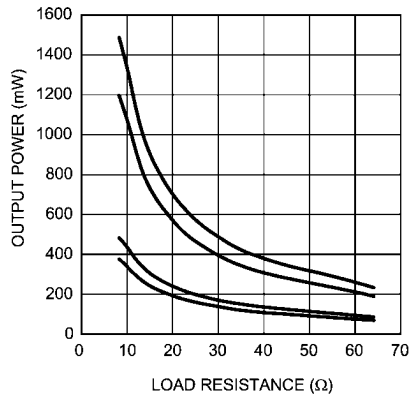

20153587

LM4844TL Output Power vs Load Resistance, HP
 Top- $V_{DD} = 5V, 10\% THD+N$; Topmid- $V_{DD} = 5V, 1\% THD+N$
 Botmid- $V_{DD} = 3V, 10\% THD+N$;
 Bot- $V_{DD} = 3V, 1\% THD+N$

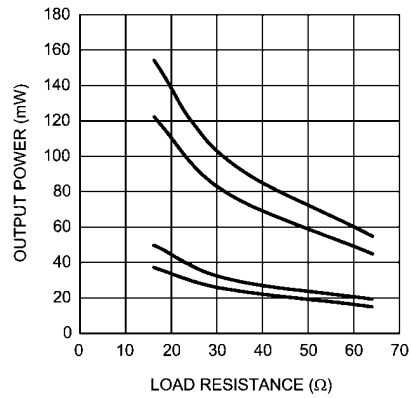

20153588

LM4844TL Output Power vs Supply Voltage, LS
 $R_L = 8\Omega$; Top- 10%THD+N, Bot- 1%THD+N

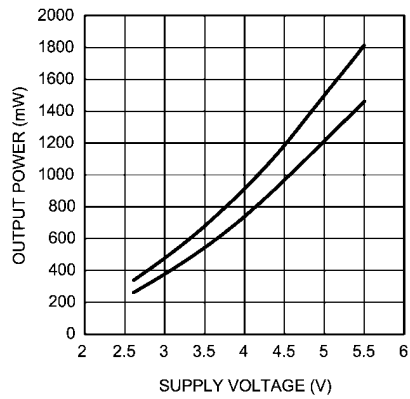

20153589

LM4844TL Output Power vs Supply Voltage, HP
 $R_L = 32\Omega$; Top- 10%THD+N, Bot- 1%THD+N

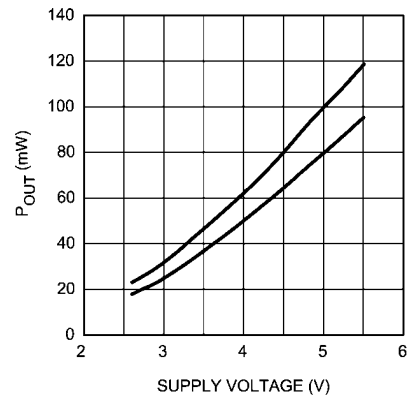

20153590

Application Information

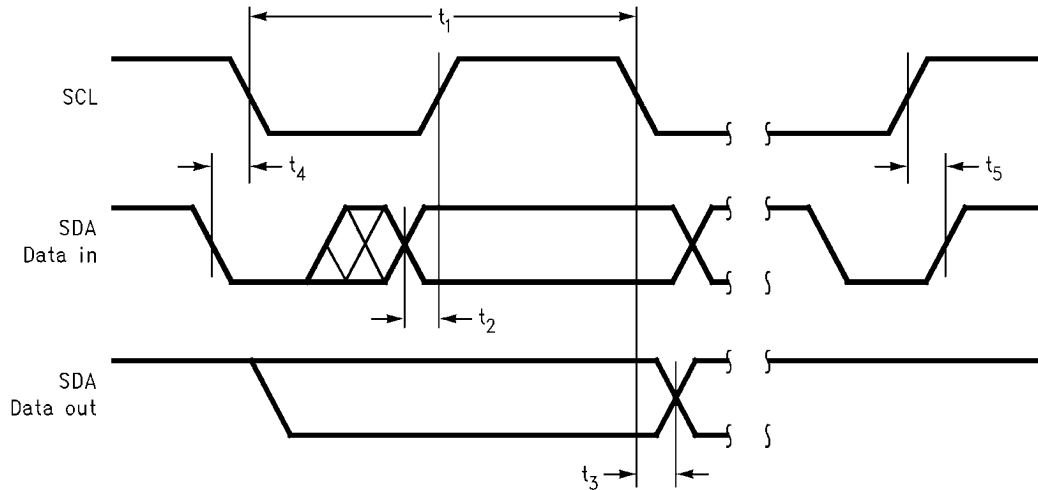

20153524

FIGURE 2. I²C Timing Diagram

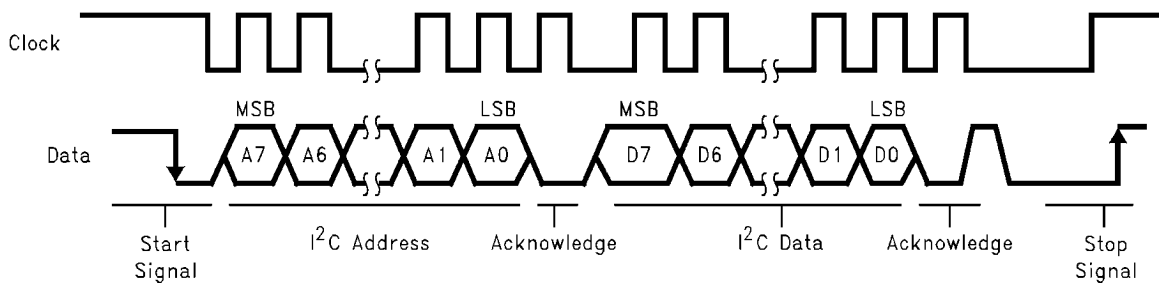

20153525

FIGURE 3. I²C Bus Format

TABLE 1. Chip Address

	A7	A6	A5	A4	A3	A2	A1	A0
Chip Address	1	1	1	1	1	0	EC	0
ADR = 0	1	1	1	1	1	0	0	0
ADR = 1	1	1	1	1	1	0	1	0

EC - externally configured by ADR pin

TABLE 2. Control Registers

	D7	D6	D5	D4	D3	D2	D1	D0
Mono Volume control	0	0	0	MD4	MD3	MD2	MD1	MD0
Left Volume control	0	1	LD5	LD4	LD3	LD2	LD1	LD0
Right Volume control	1	0	RD5	RD4	RD3	RD2	RD1	RD0
Mode control	1	1	CD5	0	CD3	CD2	CD1	CD0

TABLE 3. Mono Volume Control

MD4	MD3	MD2	MD1	MD0	Gain (dB)
0	0	0	0	0	-34.5
0	0	0	0	1	-33.0
0	0	0	1	0	-31.5
0	0	0	1	1	-30.0
0	0	1	0	0	-28.5
0	0	1	0	1	-27.0
0	0	1	1	0	-25.5
0	0	1	1	1	-24.0
0	1	0	0	0	-22.5
0	1	0	0	1	-21.0
0	1	0	1	0	-19.5
0	1	0	1	1	-18.0
0	1	1	0	0	-16.5
0	1	1	0	1	-15.0
0	1	1	1	0	-13.5
0	1	1	1	1	-12.0
1	0	0	0	0	-10.5
1	0	0	0	1	-9.0
1	0	0	1	0	-7.5
1	0	0	1	1	-6.0
1	0	1	0	0	-4.5
1	0	1	0	1	-3.0
1	0	1	1	0	-1.5
1	0	1	1	1	0.0
1	1	0	0	0	1.5
1	1	0	0	1	3.0
1	1	0	1	0	4.5
1	1	0	1	1	6.0
1	1	1	0	0	7.5
1	1	1	0	1	9.0
1	1	1	1	0	10.5
1	1	1	1	1	12.0

TABLE 4. Stereo Volume Control

LD4//RD4	LD3//RD3	LD2//RD2	LD1//RD1	LD0//RD0	Gain (dB)
0	0	0	0	0	-40.5
0	0	0	0	1	-39.0
0	0	0	1	0	-37.5
0	0	0	1	1	-36.0
0	0	1	0	0	-34.5
0	0	1	0	1	-33.0
0	0	1	1	0	-31.5
0	0	1	1	1	-30.0
0	1	0	0	0	-28.5
0	1	0	0	1	-27.0
0	1	0	1	0	-25.5
0	1	0	1	1	-24.0
0	1	1	0	0	-22.5
0	1	1	0	1	-21.0
0	1	1	1	0	-19.5
0	1	1	1	1	-18.0
1	0	0	0	0	-16.5
1	0	0	0	1	-15.0
1	0	0	1	0	-13.5
1	0	0	1	1	-12.0
1	0	1	0	0	-10.5
1	0	1	0	1	-9.0
1	0	1	1	0	-7.5
1	0	1	1	1	-6.0
1	1	0	0	0	-4.5
1	1	0	0	1	-3.0
1	1	0	1	0	-1.5
1	1	0	1	1	0.0
1	1	1	0	0	1.5
1	1	1	0	1	3.0
1	1	1	1	0	4.5
1	1	1	1	1	6.0

TABLE 5. Mixer and Output Mode

Mode	CD3	CD2	CD1	CD0	Loudspeaker L	Loudspeaker R	Headphone L	Headphone R
0	0	0	0	0	SD	SD	SD	SD
1	0	0	0	1	RESERVED			
2	0	0	1	0	$2(G_M \times M)$	$2(G_M \times M)$	MUTE	MUTE
3	0	0	1	1	$2(G_M \times M)$	$2(G_M \times M)$	$(G_M \times M)$	$(G_M \times M)$
4	0	1	0	0	SD	SD	$(G_M \times M)$	$(G_M \times M)$
5	0	1	0	1	RESERVED			
6	0	1	1	0	RESERVED			
7	0	1	1	1	$2(G_L \times L)$	$2(G_R \times R)$	MUTE	MUTE
8	1	0	0	0	$2(G_L \times L)$	$2(G_R \times R)$	$(G_L \times L)$	$(G_R \times R)$
9	1	0	0	1	SD	SD	$(G_L \times L)$	$(G_R \times R)$
10	1	0	1	0	RESERVED			
11	1	0	1	1	RESERVED			
12	1	1	0	0	$2(G_L \times L) + 2(G_M \times M)$	$2(G_R \times R) + 2(G_M \times M)$	MUTE	MUTE
13	1	1	0	1	$2(G_L \times L) + 2(G_M \times M)$	$2(G_R \times R) + 2(G_M \times M)$	$(G_L \times L) + (G_M \times M)$	$(G_R \times R) + (G_M \times M)$
14	1	1	1	0	SD	SD	$(G_L \times L) + (G_M \times M)$	$(G_R \times R) + (G_M \times M)$
15	1	1	1	1	RESERVED			

M - M_{IN} Input LevelL - L_{IN} Input LevelR - R_{IN} Input Level G_M - Mono Volume Control Gain G_L - Left Stereo Volume Control Gain G_R - Right Stereo Volume Control Gain

SD - Shutdown

MUTE - Mute

TABLE 6. National 3D Enhancement

LD5	0	Loudspeaker National 3D Off
	1	Loudspeaker National 3D On
RD5	0	Headphone National 3D Off
	1	Headphone National 3D On

TABLE 7. Wake-up Time Select

CD5	0	Fast Wake-up Setting
	1	Slow Wake-up Setting

I²C COMPATIBLE INTERFACE

The LM4844 uses a serial bus, which conforms to the I²C protocol, to control the chip's functions with two wires: clock (SCL) and data (SDA). The clock line is uni-directional. The data line is bi-directional (open-collector). The maximum clock frequency specified by the I²C standard is 400kHz. In this discussion, the master is the controlling microcontroller and the slave is the LM4844.

The I²C address for the LM4844 is determined using the ADR pin. The LM4844's two possible I²C chip addresses are of the form 111110X₁0 (binary), where X₁ = 0, if ADR is logic low; and X₁ = 1, if ADR is logic high. If the I²C interface is used to address a number of chips in a system, the LM4844's chip address can be changed to avoid any possible address conflicts.

The bus format for the I²C interface is shown in Figure 2. The bus format diagram is broken up into six major sections:

The "start" signal is generated by lowering the data signal while the clock signal is high. The start signal will alert all devices attached to the I²C bus to check the incoming address against their own address.

The 8-bit chip address is sent next, most significant bit first. The data is latched in on the rising edge of the clock. Each address bit must be stable while the clock level is high.

After the last bit of the address bit is sent, the master releases the data line high (through a pull-up resistor). Then the master sends an acknowledge clock pulse. If the LM4844 has received the address correctly, then it holds the data line low during the clock pulse. If the data line is not held low during the acknowledge clock pulse, then the master should abort the rest of the data transfer to the LM4844.

The 8 bits of data are sent next, most significant bit first. Each data bit should be valid while the clock level is stable high.

After the data byte is sent, the master must check for another acknowledge to see if the LM4844 received the data.

If the master has more data bytes to send to the LM4844, then the master can repeat the previous two steps until all data bytes have been sent.

The "stop" signal ends the transfer. To signal "stop", the data signal goes high while the clock signal is high. The data line should be held high when not in use.

I²C INTERFACE POWER SUPPLY PIN (I²CV_{DD})

The LM4844's I²C interface is powered up through the I²CV_{DD} pin. The LM4844's I²C interface operates at a voltage level set by the I²CV_{DD} pin which can be set independent to that of the main power supply pin V_{DD}. This is ideal whenever logic levels for the I²C interface are dictated by a microcontroller or microprocessor that is operating at a lower supply voltage than the main battery of a portable system.

NATIONAL 3D ENHANCEMENT

The LM4844 features a 3D audio enhancement effect that widens the perceived soundstage from a stereo audio signal. The 3D audio enhancement improves the apparent stereo channel separation whenever the left and right speakers are too close to one another, due to system size constraints or equipment limitations.

An external RC network, shown in Figure 1, is required to enable the 3D effect. There are separate RC networks for both the stereo loudspeaker outputs as well as the stereo headphone outputs, so the 3D effect can be set independently for each set of stereo outputs.

The amount of the 3D effect is set by the R_{3D} resistor. Decreasing the value of R_{3D} will increase the 3D effect. The

C_{3D} capacitor sets the low cutoff frequency of the 3D effect. Increasing the value of C_{3D} will decrease the low cutoff frequency at which the 3D effect starts to occur, as shown by Equation 1.

$$f_{3D(-3dB)} = 1 / 2\pi(R_{3D})(C_{3D}) \quad (1)$$

Activating the 3D effect will cause an increase in gain by a multiplication factor of (1 + 20kΩ/R_{3D}). Setting R_{3D} to 20kΩ will result in a gain increase by a multiplication factor of (1 + 20kΩ/20kΩ) = 2 or 6dB whenever the 3D effect is activated. The volume control can be programmed through the I²C compatible interface to compensate for the extra 6dB increase in gain. For example, if the stereo volume control is set at 0dB (11011 from Table 4) before the 3D effect is activated, the volume control should be programmed to -6dB (10111 from Table 4) immediately after the 3D effect has been activated. Setting R_{3D} = 20kΩ and C_{3D} = 0.22μF allows the LM4844 to produce a pronounced 3D effect with a minimal increase in output noise.

OUTPUT CAPACITOR-LESS (OCL) OPERATION AND LAYOUT TECHNIQUES FOR OPTIMUM CROSSTALK

The LM4844's OCL headphone architecture eliminates output coupling capacitors. Unless the headphone is in shutdown, the OCL output will be at a bias voltage of ½V_{DD}, which is applied to the stereo headphone jack's sleeve. This voltage matches the bias voltage present on LHP and RHP outputs that drive the headphones. The headphones operate in a manner similar to a bridge-tied load (BTL). Because the same DC voltage is applied to both headphone speaker terminals there is no net DC current flow through the speaker. AC current flows through a headphone speaker as an audio signal's output amplitude increases on the speaker's terminal.

The headphone jack's sleeve is not connected to circuit ground when used in OCL mode. Using the headphone output jack as a line-level output will place the LM4844's ½V_{DD} bias voltage on a plug's sleeve connection.

Since the LHP and RHP outputs of the LM4844 share the OCL output as a reference, certain layout techniques should be used in order to achieve optimum crosstalk performance. The crosstalk will depend on the parasitic resistance of the trace connecting the LM4844 OCL output to the headphone jack sleeve and on the load resistance value. Since the load resistance is often predetermined, it is advisable to use a trace that is as short and as wide as possible. Reasonable application of this layout technique will result in crosstalk values of 60dB, as specified in the electrical characteristics table.

BRIDGE CONFIGURATION EXPLANATION

The LM4844 consists of two sets of bridged-tied amplifier pairs that drive the left loudspeaker (LLS) and the right loudspeaker (RLS). For this discussion, only the LLS bridge-tied amplifier pair will be referred to. The LM4844 drives a load, such as a speaker, connected between outputs, LLS+ and LLS-. In the LLS amplifier block, the output of the amplifier that drives LLS- serves as the input to the unity gain inverting amplifier that drives LLS+.

This results in both amplifiers producing signals identical in magnitude, but 180° out of phase. Taking advantage of this phase difference, a load is placed between LLS- and LLS+ and driven differentially (commonly referred to as 'bridge mode'). This results in a differential or BTL gain of:

$$A_{VD} = 2(R_f / R_i) = 2 \quad (2)$$

Both the feedback resistor, R_f , and the input resistor, R_i , are internally set.

Bridge mode amplifiers are different from single-ended amplifiers that drive loads connected between a single amplifier's output and ground. For a given supply voltage, bridge mode has a distinct advantage over the single-ended configuration: its differential output doubles the voltage swing across the load. Theoretically, this produces four times the output power when compared to a single-ended amplifier under the same conditions. This increase in attainable output power assumes that the amplifier is not current limited and that the output signal is not clipped.

Another advantage of the differential bridge output is no net DC voltage across the load. This is accomplished by biasing LLS- and LLS+ outputs at half-supply. This eliminates the coupling capacitor that single supply, single-ended amplifiers require. Eliminating an output coupling capacitor in a typical single-ended configuration forces a single-supply amplifier's half-supply bias voltage across the load. This increases internal IC power dissipation and may permanently damage loads such as speakers.

POWER DISSIPATION

Power dissipation is a major concern when designing a successful single-ended or bridged amplifier.

A direct consequence of the increased power delivered to the load by a bridge amplifier is higher internal power dissipation. The LM4844 has 2 sets of bridged-tied amplifier pairs driving LLS and RLS. The maximum internal power dissipation operating in the bridge mode is twice that of a single-ended amplifier. From Equation (3) and (4), assuming a 5V power supply and an 8Ω load, the maximum power dissipation for LLS and RLS is 634mW per channel.

$$P_{\text{DMAX-LLS}} = 4(V_{\text{DD}})^2 / (2\pi^2 R_L): \text{ Bridged} \quad (3)$$

$$P_{\text{DMAX-RLS}} = 4(V_{\text{DD}})^2 / (2\pi^2 R_L): \text{ Bridged} \quad (4)$$

The LM4844 also has a pair of single-ended amplifiers driving LHP and RHP. The maximum internal power dissipation for ROUT and LOUT is given by equation (5) and (6). From Equations (5) and (6), assuming a 5V power supply and a 32Ω load, the maximum power dissipation for LOUT and ROUT is 40mW per channel.

$$P_{\text{DMAX-LHP}} = (V_{\text{DD}})^2 / (2\pi^2 R_L): \text{ Single-ended} \quad (5)$$

$$P_{\text{DMAX-RHP}} = (V_{\text{DD}})^2 / (2\pi^2 R_L): \text{ Single-ended} \quad (6)$$

The maximum internal power dissipation of the LM4844 occurs during output modes 3, 8, and 13 when both loudspeaker and headphone amplifiers are simultaneously on; and is given by Equation (7).

$$P_{\text{DMAX-TOTAL}} = P_{\text{DMAX-LLS}} + P_{\text{DMAX-RLS}} + P_{\text{DMAX-LHP}} + P_{\text{DMAX-RHP}} \quad (7)$$

The maximum power dissipation point given by Equation (7) must not exceed the power dissipation given by Equation (8):

$$P_{\text{DMAX}'} = (T_{\text{JMAX}} - T_A) / \theta_{\text{JA}} \quad (8)$$

The LM4844's $T_{\text{JMAX}} = 150^\circ\text{C}$. In the TL package, the LM4844's θ_{JA} is 62°C/W . At any given ambient temperature T_A , use Equation (8) to find the maximum internal power dissipation supported by the IC packaging. Rearranging Equation (8) and substituting $P_{\text{DMAX-TOTAL}}$ for $P_{\text{DMAX}'}$ results in Equation (9). This equation gives the maximum ambient temperature that still allows maximum stereo power dissipation without violating the LM4844's maximum junction temperature.

$$T_A = T_{\text{JMAX}} - P_{\text{DMAX-TOTAL}} \theta_{\text{JA}} \quad (9)$$

For a typical application with a 5V power supply, stereo 8Ω loudspeaker load, and the stereo 32Ω headphone load, the maximum ambient temperature that allows maximum stereo power dissipation without exceeding the maximum junction temperature is approximately 100°C for the TL package.

$$T_{\text{JMAX}} = P_{\text{DMAX-TOTAL}} \theta_{\text{JA}} + T_A \quad (10)$$

Equation (10) gives the maximum junction temperature T_{JMAX} . If the result violates the LM4844's 150°C , reduce the maximum junction temperature by reducing the power supply voltage or increasing the load resistance. Further allowance should be made for increased ambient temperatures.

The above examples assume that a device is a surface mount part operating around the maximum power dissipation point. Since internal power dissipation is a function of output power, higher ambient temperatures are allowed as output power or duty cycle decreases. If the result of Equation (7) is greater than that of Equation (8), then decrease the supply voltage, increase the load impedance, or reduce the ambient temperature. If these measures are insufficient, a heat sink can be added to reduce θ_{JA} . The heat sink can be created using additional copper area around the package, with connections to the ground pin(s), supply pin and amplifier output pins. External, solder attached SMT heatsinks such as the Thermalloy 7106D can also improve power dissipation. When adding a heat sink, the θ_{JA} is the sum of θ_{JC} , θ_{CS} , and θ_{SA} . (θ_{JC} is the junction-to-case thermal impedance, θ_{CS} is the case-to-sink thermal impedance, and θ_{SA} is the sink-to-ambient thermal impedance.) Refer to the Typical Performance Characteristics curves for power dissipation information at lower output power levels.

POWER SUPPLY BYPASSING

As with any power amplifier, proper supply bypassing is critical for low noise performance and high power supply rejection. Applications that employ a 5V regulator typically use a 10 μ F in parallel with a 0.1 μ F filter capacitors to stabilize the regulator's output, reduce noise on the supply line, and improve the supply's transient response. However, their presence does not eliminate the need for a local 1.0 μ F tantalum bypass capacitance connected between the LM4844's supply pins and ground. Keep the length of leads and traces that connect capacitors between the LM4844's power supply pin and ground as short as possible.

SELECTING EXTERNAL COMPONENTS

Input Capacitor Value Selection

Amplifying the lowest audio frequencies requires a high value input coupling capacitor (C_i in Figure 1). In many cases, however, the speakers used in portable systems, whether internal or external, have little ability to reproduce signals below 50Hz. Applications using speakers with this limited frequency response reap little improvement; by using a large input capacitor.

The internal input resistor (R_i) and the input capacitor (C_i) produce a high pass filter cutoff frequency that is found using Equation (13).

$$f_c = 1 / (2\pi R_i C_i) \quad (11)$$

As an example when using a speaker with a low frequency limit of 50Hz and $R_i = 20k\Omega$, C_i , using Equation (13) is 0.19 μ F. The 0.22 μ F C_i shown in Figure 4 allows the LM4844 to drive high efficiency, full range speaker whose response extends below 40Hz.

Bypass Capacitor Value Selection

Besides minimizing the input capacitor size, careful consideration should be paid to value of C_B , the capacitor connected to the BYPASS pin. Since C_B determines how fast the LM4844 settles to quiescent operation, its value is critical when minimizing turn-on pops. The slower the LM4844's outputs ramp to their quiescent DC voltage (nominally $V_{DD}/2$), the smaller the turn-on pop. Choosing C_B equal to 2.2 μ F along with a small value of C_i (in the range of 0.1 μ F to 0.39 μ F), produces a click-less and pop-less shutdown function. As discussed above, choosing C_i no larger than necessary for the desired bandwidth helps minimize clicks and pops. C_B 's value should be in the range of 5 times to 10 times the value of C_i . This ensures that output transients are eliminated when the LM4844 transitions in and out of shutdown mode. Connecting a 2.2 μ F capacitor, C_B , between the BYPASS pin and ground improves the internal bias voltage's stability and improves the amplifier's PSRR. The PSRR improvements increase as the bypass pin capacitor value increases. However, increasing the value of C_B will increase wake-up time. The selection of bypass capacitor value, C_B , depends on desired PSRR requirements, click and pop performance, wake-up time, system cost, and size constraints.

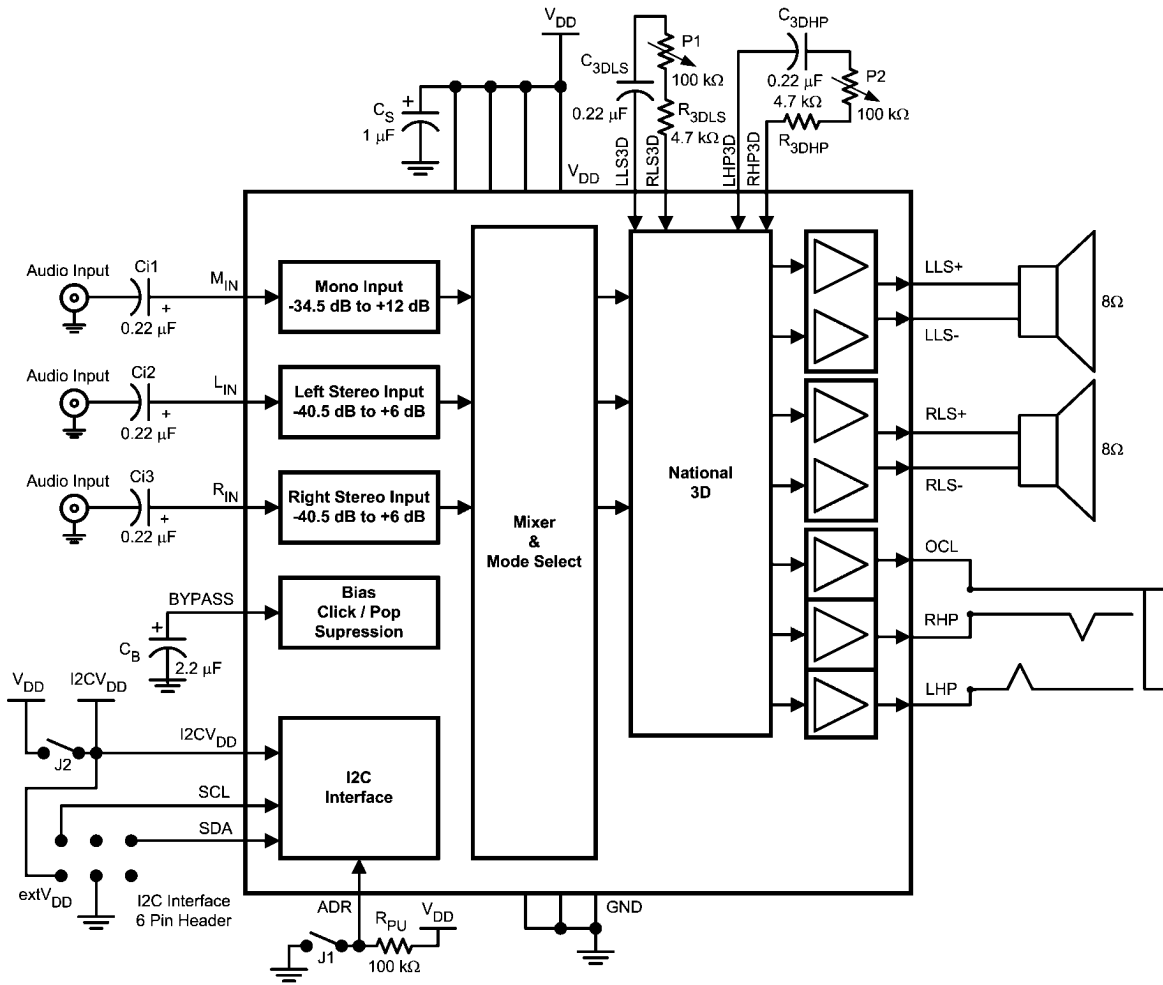

20153532

FIGURE 4. Reference Design Board Schematic

Demonstration Board Layout

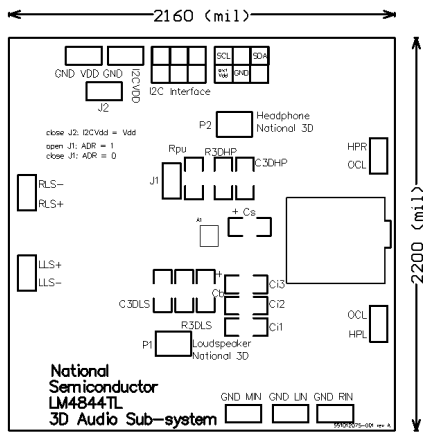

Recommended TL PCB Layout:
Silkscreen Layer

20153517

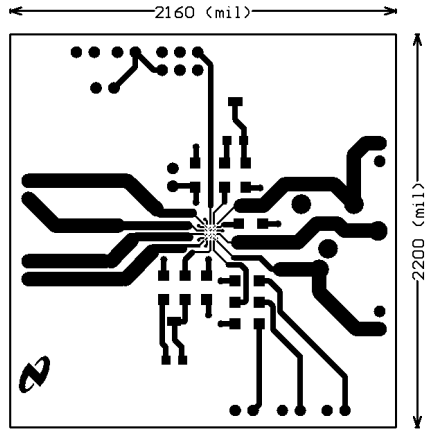

Recommended TL PCB Layout:
Top Layer

20153518

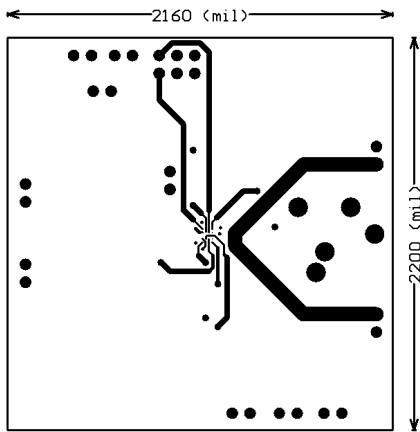

Recommended TL PCB Layout:
Mid Layer 1

20153515

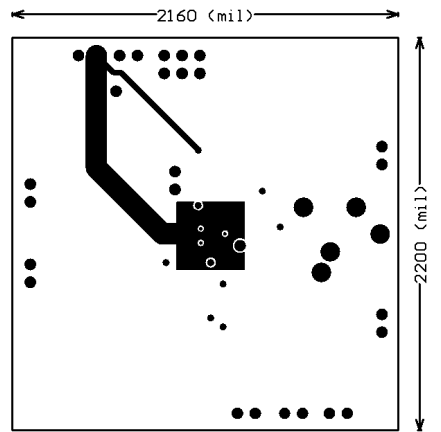

Recommended TL PCB Layout:
Mid Layer 2

20153516

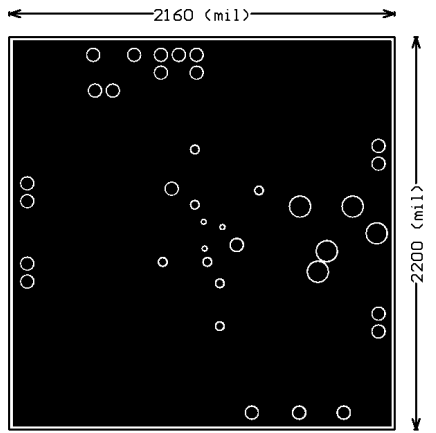

Recommended TL PCB Layout:
Bottom Layer

20153514

Revision History

Rev	Date	Description
1.1	06/01/06	Initial WEB.
1.2	07/20/07	Edited the Control Interface Electrical Characteristics tables.
1.3	08/07/07	Changed the I ² C V _{DD} from 1.8V into 1.7V (under the Operating Ratings).
1.4	08/23/07	Fixed one place of typo.

Physical Dimensions inches (millimeters) unless otherwise noted

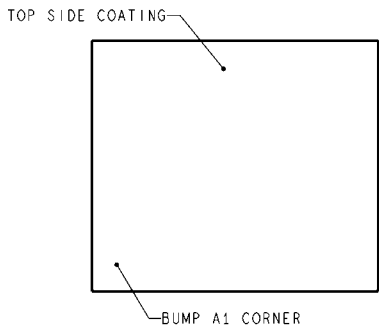
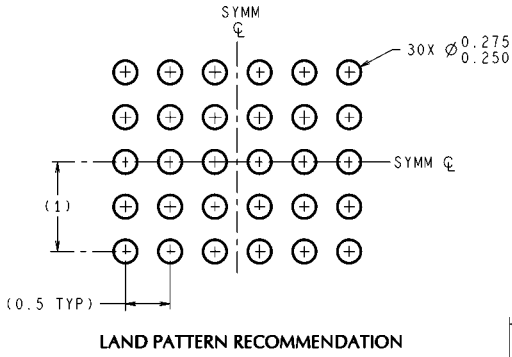

DIMENSIONS ARE IN MILLIMETERS
DIMENSIONS IN () FOR REFERENCE ONLY

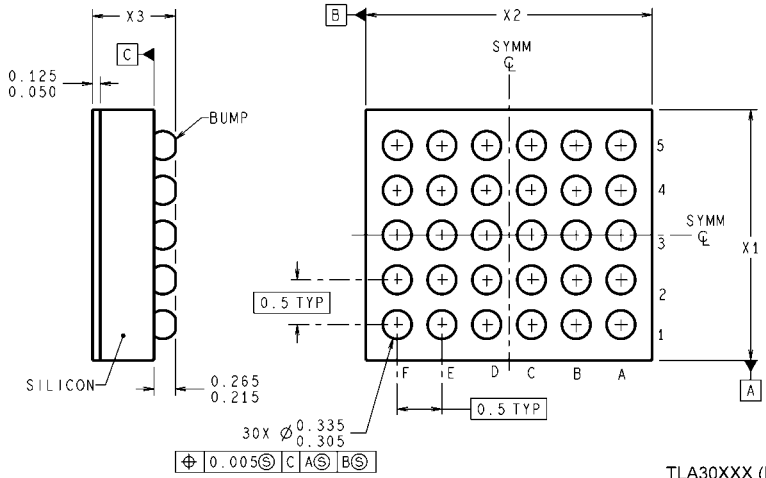

⊕	0.005	Ⓢ	C	A	Ⓢ	B	Ⓢ
---	-------	---	---	---	---	---	---

TLA30XXX (Rev C)

30 Bump Micro SMD (TL) Package
Order Number LM4844TL
NS Package Number TLA30CZA
X1 = 2.543±0.03 X2 = 2.949±0.03 X3 = 0.6±0.075

Notes

LM4844

Notes

THE CONTENTS OF THIS DOCUMENT ARE PROVIDED IN CONNECTION WITH NATIONAL SEMICONDUCTOR CORPORATION ("NATIONAL") PRODUCTS. NATIONAL MAKES NO REPRESENTATIONS OR WARRANTIES WITH RESPECT TO THE ACCURACY OR COMPLETENESS OF THE CONTENTS OF THIS PUBLICATION AND RESERVES THE RIGHT TO MAKE CHANGES TO SPECIFICATIONS AND PRODUCT DESCRIPTIONS AT ANY TIME WITHOUT NOTICE. NO LICENSE, WHETHER EXPRESS, IMPLIED, ARISING BY ESTOPPEL OR OTHERWISE, TO ANY INTELLECTUAL PROPERTY RIGHTS IS GRANTED BY THIS DOCUMENT.

TESTING AND OTHER QUALITY CONTROLS ARE USED TO THE EXTENT NATIONAL DEEMS NECESSARY TO SUPPORT NATIONAL'S PRODUCT WARRANTY. EXCEPT WHERE MANDATED BY GOVERNMENT REQUIREMENTS, TESTING OF ALL PARAMETERS OF EACH PRODUCT IS NOT NECESSARILY PERFORMED. NATIONAL ASSUMES NO LIABILITY FOR APPLICATIONS ASSISTANCE OR BUYER PRODUCT DESIGN. BUYERS ARE RESPONSIBLE FOR THEIR PRODUCTS AND APPLICATIONS USING NATIONAL COMPONENTS. PRIOR TO USING OR DISTRIBUTING ANY PRODUCTS THAT INCLUDE NATIONAL COMPONENTS, BUYERS SHOULD PROVIDE ADEQUATE DESIGN, TESTING AND OPERATING SAFEGUARDS.

EXCEPT AS PROVIDED IN NATIONAL'S TERMS AND CONDITIONS OF SALE FOR SUCH PRODUCTS, NATIONAL ASSUMES NO LIABILITY WHATSOEVER, AND NATIONAL DISCLAIMS ANY EXPRESS OR IMPLIED WARRANTY RELATING TO THE SALE AND/OR USE OF NATIONAL PRODUCTS INCLUDING LIABILITY OR WARRANTIES RELATING TO FITNESS FOR A PARTICULAR PURPOSE, MERCHANTABILITY, OR INFRINGEMENT OF ANY PATENT, COPYRIGHT OR OTHER INTELLECTUAL PROPERTY RIGHT.

LIFE SUPPORT POLICY

NATIONAL'S PRODUCTS ARE NOT AUTHORIZED FOR USE AS CRITICAL COMPONENTS IN LIFE SUPPORT DEVICES OR SYSTEMS WITHOUT THE EXPRESS PRIOR WRITTEN APPROVAL OF THE CHIEF EXECUTIVE OFFICER AND GENERAL COUNSEL OF NATIONAL SEMICONDUCTOR CORPORATION. As used herein:

Life support devices or systems are devices which (a) are intended for surgical implant into the body, or (b) support or sustain life and whose failure to perform when properly used in accordance with instructions for use provided in the labeling can be reasonably expected to result in a significant injury to the user. A critical component is any component in a life support device or system whose failure to perform can be reasonably expected to cause the failure of the life support device or system or to affect its safety or effectiveness.

National Semiconductor and the National Semiconductor logo are registered trademarks of National Semiconductor Corporation. All other brand or product names may be trademarks or registered trademarks of their respective holders.

Copyright© 2007 National Semiconductor Corporation

For the most current product information visit us at www.national.com



National Semiconductor Americas Customer Support Center
 Email: new.feedback@nsc.com
 Tel: 1-800-272-9959

National Semiconductor Europe Customer Support Center
 Fax: +49 (0) 180-530-85-86
 Email: europe.support@nsc.com
 Deutsch Tel: +49 (0) 69 9508 6208
 English Tel: +49 (0) 870 24 0 2171
 Français Tel: +33 (0) 1 41 91 8790

National Semiconductor Asia Pacific Customer Support Center
 Email: ap.support@nsc.com

National Semiconductor Japan Customer Support Center
 Fax: 81-3-5639-7507
 Email: jpn.feedback@nsc.com
 Tel: 81-3-5639-7560