

April 1995

15A, 400V - 600V Ultrafast Diodes

Features

- Ultrafast with Soft Recovery Characteristic ($t_{RR} < 55\text{ns}$)
- +175°C Rated Junction Temperature
- Reverse Voltage Up to 600V
- Avalanche Energy Rated

Applications

- Switching Power Supply
- Power Switching Circuits
- General Purpose

Description

MUR1540, MUR1550, MUR1560 and RURP1540, RURP1550, RURP1560 are ultrafast dual diodes ($t_{RR} < 55\text{ns}$) with soft recovery characteristics. They have a low forward voltage drop and are of planar, silicon nitride passivated, ion-implanted, epitaxial construction.

These devices are intended for use as energy steering/clamping diodes and rectifiers in a variety of switching power supplies and other power switching applications. Their low stored charge and ultrafast recovery with soft recovery characteristics minimizes ringing and electrical noise in many power switching circuits thus reducing power loss in the switching transistor.

Package

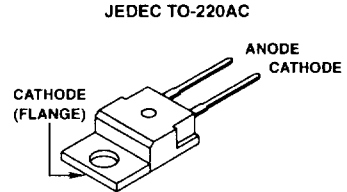

Symbol



PACKAGING AVAILABILITY

PART NUMBER	PACKAGE	BRAND
MUR1540	TO-220AC	MUR1540
RURP1540	TO-220AC	RURP1540
MUR1550	TO-220AC	MUR1550
RURP1550	TO-220AC	RURP1550
MUR1560	TO-220AC	MUR1560
RURP1560	TO-220AC	RURP1560

NOTE: When ordering, use the entire part number

Absolute Maximum Ratings $T_C = +25^\circ\text{C}$, Unless Otherwise Specified

	MUR1540 RURP1540	MUR1550 RURP1550	MUR1560 RURP1560
Peak Repetitive Reverse Voltage..... V_{RRM}	400V	500V	600V
Working Peak Reverse Voltage..... V_{RWM}	400V	500V	600V
DC Blocking Voltage..... V_R	400V	500V	600V
Average Rectified Forward Current..... $I_{F(AV)}$ (Total device forward current at rated V_R and $T_C = +150^\circ\text{C}$)	15A	15A	15A
Peak Forward Repetitive Current..... I_{FRM} (Rated V_R , square wave 20kHz)	30A	30A	30A
Nonrepetitive Peak Surge Current..... I_{FSM} (Surge applied at rated load condition halfwave 1 phase 60Hz)	200A	200A	200A
Operating and Storage Temperature..... T_{STG}, T_J	-55°C to +175°C	-55°C to +175°C	-55°C to +175°C

Specifications MUR1540, MUR1550, MUR1560, RURP1540, RURP1550, RURP1560

Electrical Specifications $T_C = +25^\circ\text{C}$, Unless Otherwise Specified.

SYMBOL	TEST CONDITION	LIMITS									UNITS
		MUR1540, RURP1540			MUR1550, RURP1550			MUR1560, RURP1560			
		MIN	TYP	MAX	MIN	TYP	MAX	MIN	TYP	MAX	
V_F	$I_F = 15\text{A}$ $T_C = +150^\circ\text{C}$	-	-	1.12	-	-	1.20	-	-	1.20	V
	$I_F = 15\text{A}$ $T_C = +25^\circ\text{C}$	-	-	1.25	-	-	1.50	-	-	1.50	V
I_R at $T_C = +150^\circ\text{C}$	$V_R = 400\text{V}$	-	-	500	-	-	-	-	-	-	μA
	$V_R = 500\text{V}$	-	-	-	-	-	500	-	-	-	μA
	$V_R = 600\text{V}$	-	-	-	-	-	-	-	-	500	μA
I_R at $T_C = +25^\circ\text{C}$	$V_R = 400\text{V}$	-	-	100	-	-	-	-	-	-	μA
	$V_R = 500\text{V}$	-	-	-	-	-	100	-	-	-	μA
	$V_R = 600\text{V}$	-	-	-	-	-	-	-	-	100	μA
t_{RR}	$I_F = 1\text{A}$	-	-	55	-	-	55	-	-	55	ns
	$I_F = 15\text{A}$	-	-	60	-	-	60	-	-	60	ns
t_A	$I_F = 1\text{A}$	-	20	-	-	20	-	-	20	-	ns
	$I_F = 15\text{A}$	-	30	-	-	30	-	-	30	-	ns
t_B	$I_F = 1\text{A}$	-	15	-	-	15	-	-	15	-	ns
	$I_F = 15\text{A}$	-	17	-	-	17	-	-	20	-	ns
R_{thJC}		-	-	1.5	-	-	1.5	-	-	1.5	$^\circ\text{C/W}$
E_{AVL}	See Fig. 7 & 8	-	-	20	-	-	20	-	-	20	mj

DEFINITIONS

- V_F = Instantaneous forward voltage ($p_w = 300\mu\text{s}$, $D = 2\%$).
- I_R = Instantaneous reverse current.
- t_{RR} = Reverse recovery time at $dI_F/dt = 100\text{A}/\mu\text{s}$ (See Figure 2), summation of $t_A + t_B$.
- t_A = Time to reach peak reverse current at $dI_F/dt = 100\text{A}/\mu\text{s}$ (See Figure 2).
- t_B = Time from peak I_{RM} to projected zero crossing of I_{RM} based on a straight line from peak I_{RM} through 25% of I_{RM} (See Figure 2).
- R_{thJC} = Thermal resistance junction to case.
- E_{AVL} = Controlled avalanche energy (See Figures 7 and 8).
- p_w = pulse width.
- D = duty cycle.

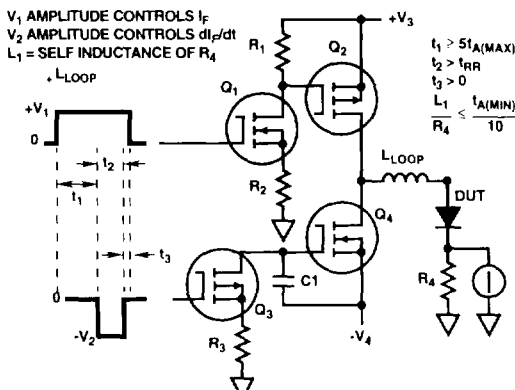

FIGURE 1. t_{RR} TEST CIRCUIT

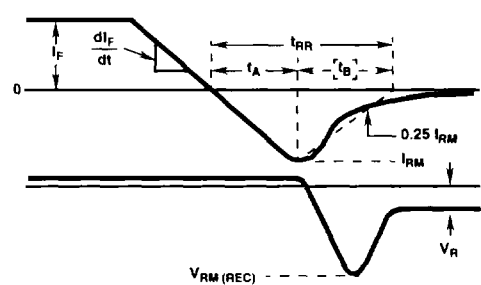

FIGURE 2. DEFINITIONS OF t_{RR} , t_A AND t_B

5

**ULTRAFAST
SINGLE DIODES**

Typical Performance Curves

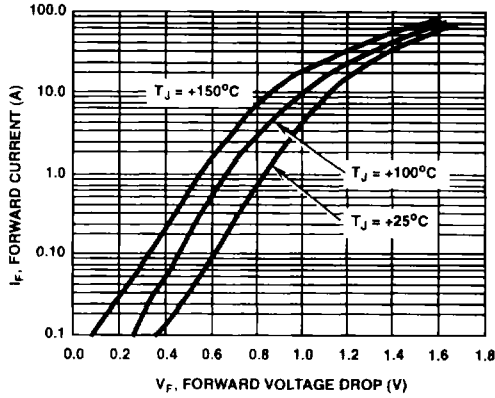

FIGURE 3. FORWARD VOLTAGE vs FORWARD CURRENT CHARACTERISTIC

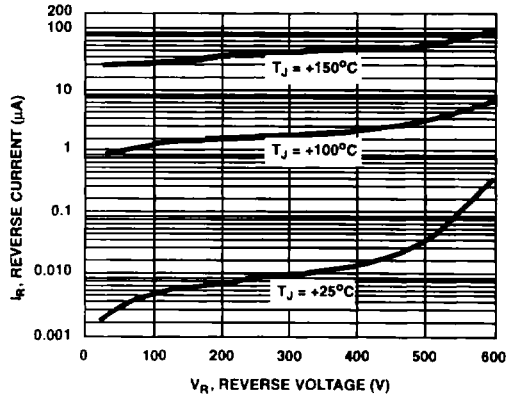

FIGURE 4. REVERSE VOLTAGE vs REVERSE CURRENT CHARACTERISTIC

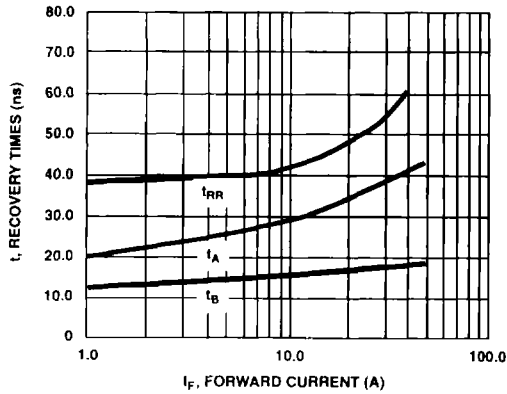

FIGURE 5. TYPICAL t_{RR} , t_A AND t_B CURVES vs FORWARD CURRENT

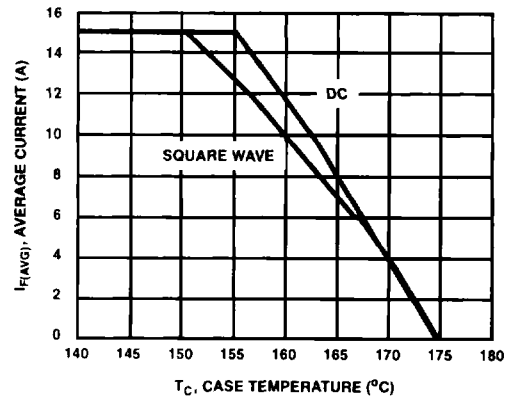

FIGURE 6. TYPICAL CURRENT DERATING CURVE vs CASE TEMPERATURE

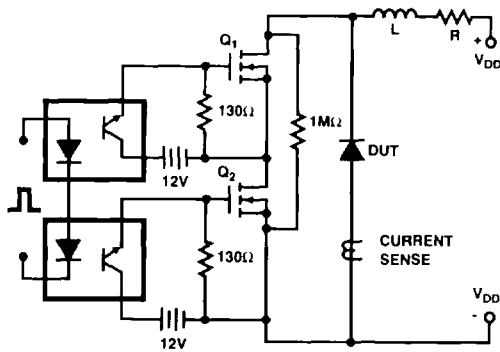

FIGURE 7. AVALANCHE ENERGY TEST CIRCUIT

$$I_{L(peak)} = 1A, L = 40mH, R < 0.1\Omega, E_{AVL} = (1/2) L I_{L(peak)}^2 [V_{AVL} / (V_{AVL} - V_{DD})]$$

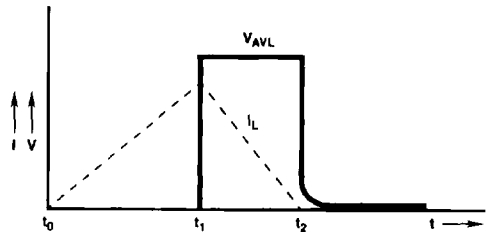

FIGURE 8. CURRENT VOLTAGE WAVEFORM