



THIS SPEC IS OBSOLETE

Spec No: 38-07521

Spec Title: CY25901 SPREAD SPECTRUM CLOCK GENERATOR

Sunset Owner: Christopher Martin (CXQ)

Replaced by: None

Spread Spectrum Clock Generator

Features

- Supports clock requirements for Spread Spectrum
- 40-MHz Spread Spectrum clock output
- Reference clock output
- Two spread bandwidths: 1%, 3%
- External clock or Cera-Lock input
- 3.3V operation
- 8-pin SOIC package

Description

The CY25901 clock generator provides a low-electromagnetic interference (EMI) clock output. It features Spread Spectrum technology, a modulation technique designed specifically for reducing EMI at the fundamental frequency and its harmonics.

Table 1. Function Table

SSSEL	SSON	REFOUT	CLKOUT (Spread Spectrum)	
			CY25901SC	CY25901SC-1
0	0	XIN	= XIN ± 0.35% (0.7% center)	= XIN ± 0.5% (1.0% center)
1	0	XIN	= XIN ± 1.20% (2.4% center)	= XIN ± 1.5% (3.0% center)
X (don't care)	1	XIN	= XIN (No Spread)	= XIN (No Spread)

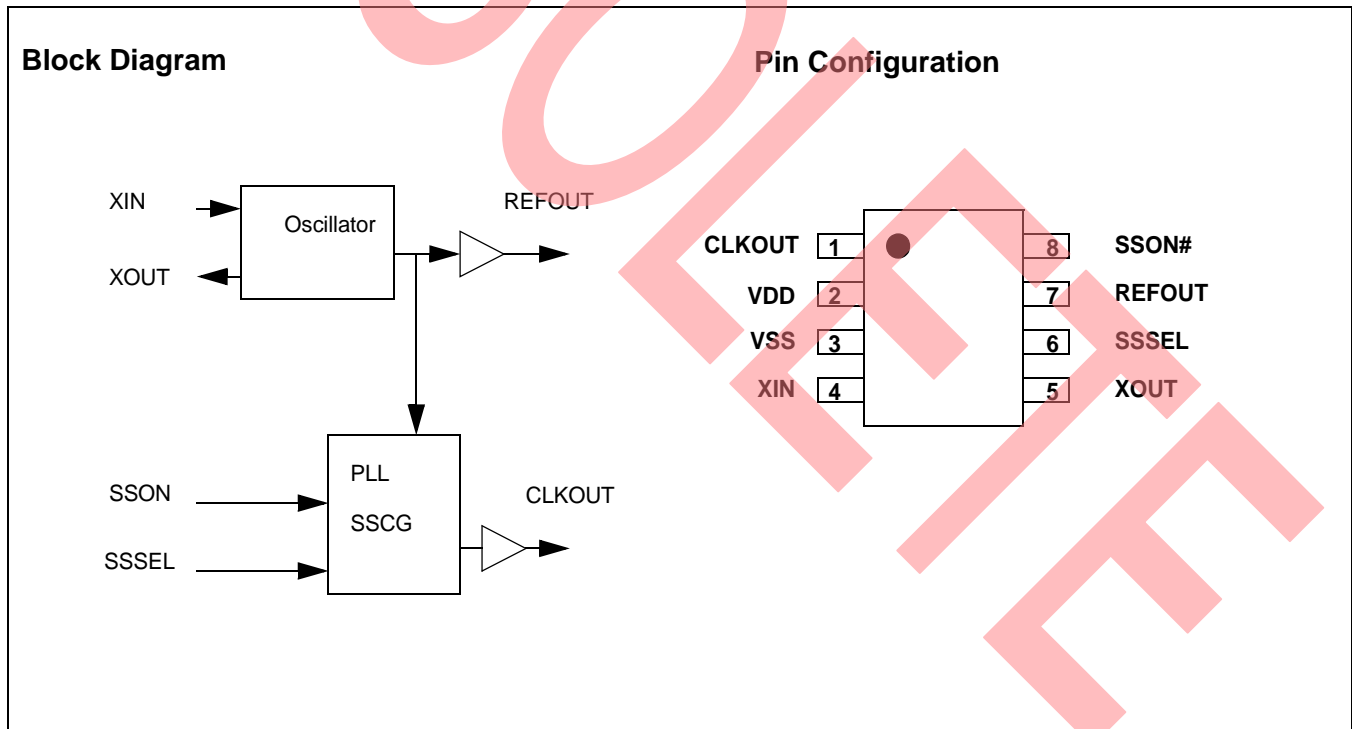

Pin Description

Pin No.	Name	I/O	Description
1	CLKOUT	O	Spread Spectrum Clock Output. See <i>Table 1</i> for frequency selections.
2	VDD	PWR	Power Supply.
3	VSS	PWR	Common Ground.
4	XIN	I	Oscillator Buffer Input. Connect to an external parallel resonant crystal or externally generated reference clock.
5	XOUT	O	Oscillator Buffer Output. Connect to an external parallel resonant crystal. Do not connect when an externally generated reference clock is applied at XIN.
6	SSSEL	I	Spread Spectrum Select Input. See <i>Table 1</i> . internally pulled up.
7	REFOUT	O	Buffered Output of XIN.
8	SSON#	I	Spread Spectrum Enable Input. When asserted low, Spread Spectrum is enabled. Internally pulled down.

Spread Spectrum Clock Generator

Spread Spectrum Clock Generator (SSCG) is a frequency modulation technique used to reduce EMI radiation generated by repetitive digital signals, mainly clocks. A clock radiates EM energy at its fundamental frequency as well as its harmonics. Spread Spectrum distributes this energy over a small frequency bandwidth, and decreasing the peak value of

radiated energy over the spectrum. This technique is achieved by modulating the clock around or below the center of its reference frequency by a certain percentage (which also determines the energy distribution bandwidth).

The SSCG function is enabled when SSON pin is set to low. Resulting in a spread bandwidth that is center spread, amount as selected by SSSEL (see *Table 1*).

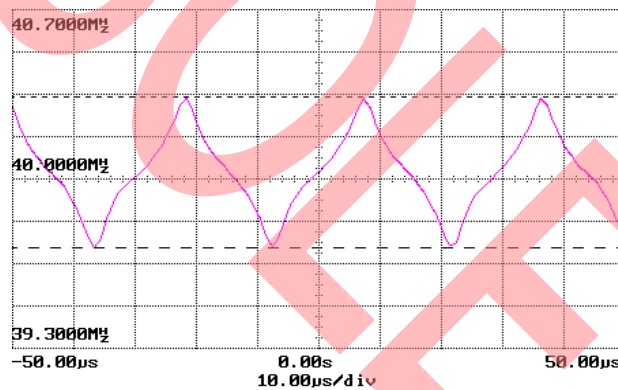
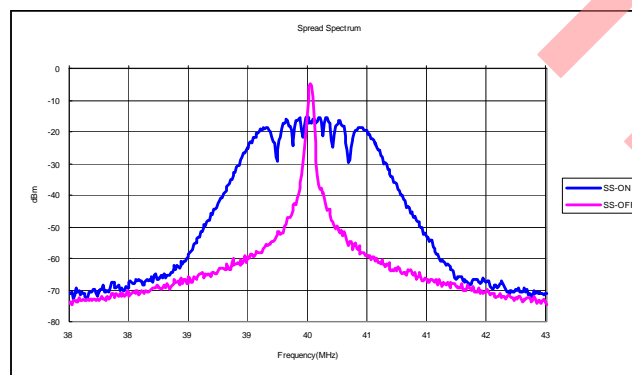
Figure 1. Modulation Frequency Profile

Figure 2. Spread Spectrum

Absolute Maximum Ratings

Parameter	Description	Condition	Min.	Max.	Unit
V _{DD}	Core Supply Voltage		-0.5	4.6	V
V _{IN}	Input Voltage	Relative to V _{SS}	-0.5	V _{DD} +0.5	VDC
T _S	Temperature, Storage	Non Functional	-65	150	°C
T _A	Temperature, Operating Ambient	Functional	-10	85	°C
T _J	Temperature, Junction	Functional	-	150	°C
ESD _{HBM}	ESD Protection (Human Body Model)	MIL-STD-883, Method 3015	2000	-	V
UL-94	Flammability Rating	@1/8 in.	V-0		
MSL	Moisture Sensitivity Level		1		

DC Specifications

Parameter	Description	Condition	Min.	Typ.	Max.	Unit
V _{DD}	Operating Voltage	3.3V @ ±10%	2.97	3.3	3.63	V
V _{IL}	Input Low Voltage ^[1]	SSON# and SSSEL	-	-	0.8	V
V _{IH}	Input High Voltage ^[1]	Inputs	2.2	-	-	V
V _{thXIN}	XIN Threshold Voltage	XIN	0.3*VDDC	0.5*VDDC	0.7*VDDC	V
I _{DD}	Dynamic Supply Current	V _{DD} = 3.3V and CL = 0	-	20	25	mA
I _{IL}	Input Low Current	SSSEL = V _{SS}	-55	-30	-	μA
I _{IH}	Input High Current	SSON = V _{DD}	-	30	55	μA
V _{OL}	Output Low Voltage	I _{OL} = 4.0 mA	-	-	0.4	V
V _{OH}	Output High Voltage	I _{OH} = -4.0 mA	2.4	-	-	V
C _{IN}	Input Capacitance	SSON# and SSSEL Inputs	-	5	10	pF
C _X	XIN, XOUT Capacitance ^[2]	XIN and XOUT	-	5	-	pF
PU/PD	Pull-up/Pull-down Resistance ^[1]	SSON# and SSSEL Inputs	50	100	200	kΩ

AC Specifications^[3]

Parameter	Description	Condition	Min.	Typ.	Max.	Unit
F _{IR}	Input Frequency Range		36	40	44	MHz
E _{RXIN}	XIN Edge Rate	XIN driven by external clock	-	1	-	V/nS
T _{DCXIN}	XIN Duty Cycle	XIN driven by external clock	40	50	60	%
T _R	Outputs Rise Time ^[4]	REFOUT, CLKOUT	-	-	3	ns
T _F	Outputs Fall Time ^[4]	REFOUT, CLKOUT	-	-	3	ns
BW%1	CY25901SC, Spread %	SSON=0,SSSEL = 0	0.5	0.7	0.9	%
BW%2	CY25901SC, Spread %	SSON=0,SSSEL = 1	1.7	2.4	3.1	%
BW%3	CY25901SC-1, Spread %	SSON=0,SSSEL = 0	0.7	1	1.3	%
BW%4	CY25901SC-1, Spread %	SSON=0,SSSEL = 1	2.1	3	3.9	%
T _{PU}	Power up to Stable Output ^[5]	All output clocks	-	-	3	ms
T _{DC}	CLKOUT Duty Cycle ^[5]	CL = 15pF	45	50	55	%
T _{CCJ}	REFOUT Cycle to Cycle jitter ^[5]	CL = 15pF	-	110	200	ps
T _{CCJ}	CLKOUT Cycle to Cycle jitter ^[5]	CL = 15pF	-	110	200	ps
F _{mod}	Frequency Modulation Rate	SSON# = GND Internally pulled down	-	31	-	kHz

Notes:

1. SSSEL has internal pull-up and SSON has pull-down resistors.
2. In applications if a crystal is used for the input reference clock, refer to crystal manufacturer's specifications for the required crystal load capacitor value.
3. Parameters are guaranteed by design and characterization. Not 100% tested in production. All parameters specified with fully loaded outputs. All outputs loaded with 15 pF.
4. Measured between 0.2*VDD and 0.8*VDD Volts.
5. Triggering is done at 1.5V VDDC.

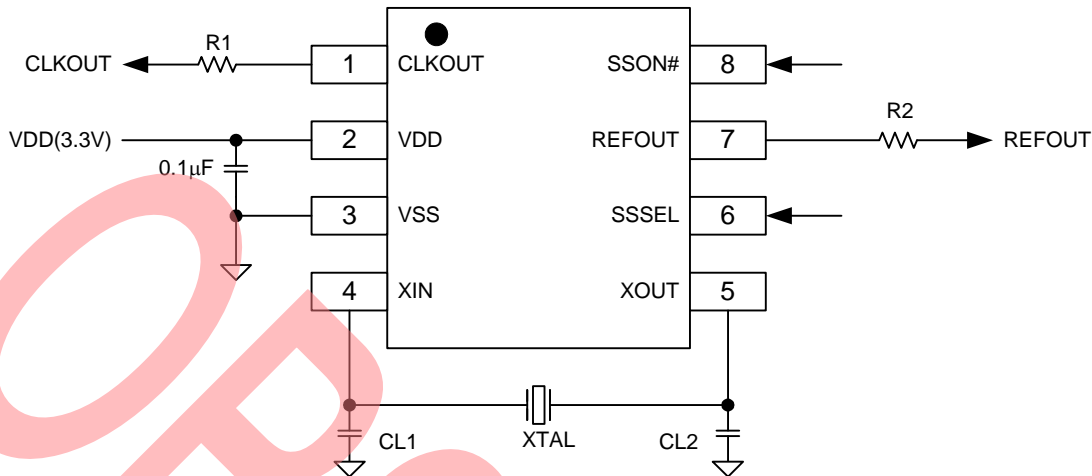
Application Schematic

Figure 3. Application Schematic

Use crystal or cera-lock filter manufacturer's recommended values for CL1 and CL2 load capacitors. 0.1-µF bypass capacitor for power pins should always be used and placed close to their V_{DD} pin. R1 and R2 are series termination resistors for impedance matching.

Ordering Information

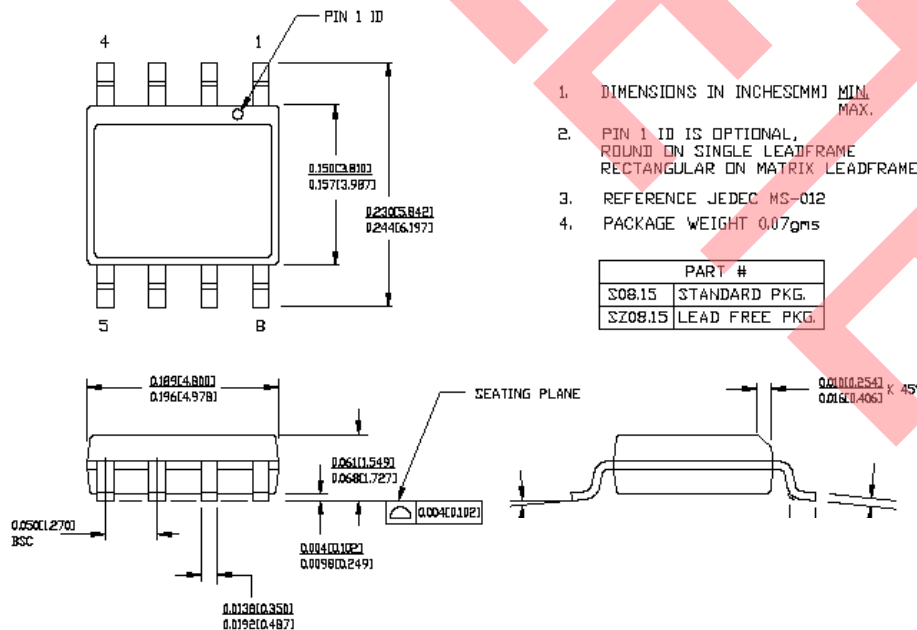
Part Number	Package Type	Production Flow
CY25901SXC-1	TBD	TBD
CY25901SXC-1T	TBD	TBD

Package Drawing and Dimensions
8-lead (150-Mil) SOIC S8

51-85066 *D

All product and company names mentioned in this document are the trademarks of their respective holders.

Document History Page

Document Title: CY25901 Spread Spectrum Clock Generator Document Number: 38-07521				
REV.	ECN NO.	Issue Date	Orig. of Change	Description of Change
**	124075	02/19/03	RGL	New Datasheet
*A	2939214	05/28/10	CXQ	Obsolete document.

OBsolete