

National Semiconductor is now part of  
Texas Instruments.

Search <http://www.ti.com/> for the latest technical  
information and details on our current products and services.

## LM3432/LM3432B

# 6-Channel Current Regulator for LED Backlight Application

### General Description

The LM3432/LM3432B are 6-channel high voltage current regulators which provide a simple solution for LED backlight applications. These devices incorporate six individual current regulator channels to give accurate driving current for each LED string. The string-to-string tolerance is kept within  $\pm 2.0\%$ . Additionally, the Dynamic Headroom Control output can communicate with a LM3430 boost regulator to adjust the LED supply voltage to the lowest level needed to keep the string current in regulation, yielding optimal overall system efficiency.

The 6-channel current sink can be adjusted from 15mA to 40mA by an external resistor. Their output drivers can withstand up to 80V. Digital PWM or analog voltage signal can be used to control the duty cycle of all the channels. With a fast current switching slew rate,  $t_r = 60\text{ns}$  typical, accurate current control and wide dimming ratio during PWM dimming are ensured.

The LM3432/LM3432B contain LED open/short circuit and over-temperature fault signaling to the system micro-controller (the LM3432B does not include open circuit fault signaling). These devices are available in a low profile, thermally enhanced 24 lead LLP package. The LM3432 is also available in the 28 lead eTSSOP.

### Features

- Dynamic Headroom Control (DHC) output to maximize efficiency when used in conjunction with National Semiconductor's LM3430 Boost Controller for LED Backlighting
- Current sinking adjustable up to 40mA in each string
- Fast current switching slew rate,  $t_r = 60\text{ns}$  typical
- Wide dimming ratio, up to 4000:1 with  $f_{\text{DIM}} = 500\text{Hz}$
- High LED driving voltage up to 80V
- $\pm 2.0\%$  current matching between strings
- Accepts both Digital and Analog dimming control
- LED open/short fault indication (For LM3432B, no open fault indication)
- Over-Temperature Indication
- Internal Thermal Shutdown with Hysteresis
- Low profile, thermally enhanced LLP-24 (5x4x0.8mm) and eTSSOP-28 (9.7x6.4x1.1mm) packages (The LM3432B is available in the LLP-24 only)

### Applications

- LCD display backlight applications
- General lighting solutions

# Typical Application Circuit

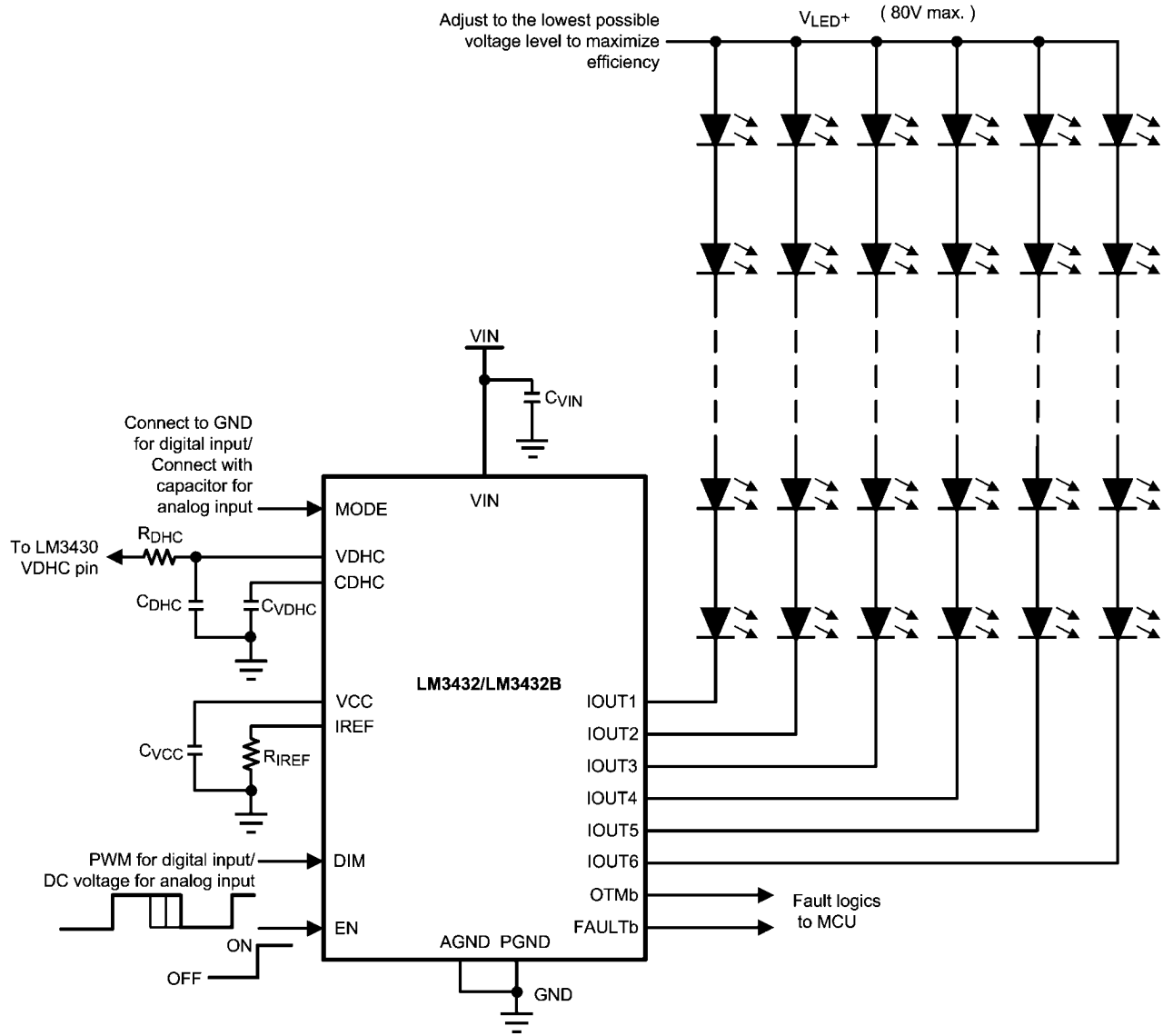

30006401

## Connection Diagrams

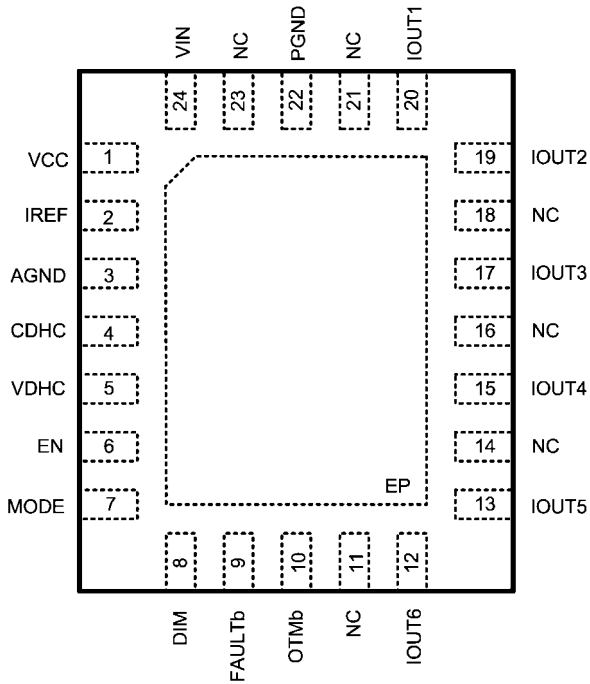

**Top View**  
**24 Lead Plastic LLP-24**  
**NS Package Number SQA24B**

30006402

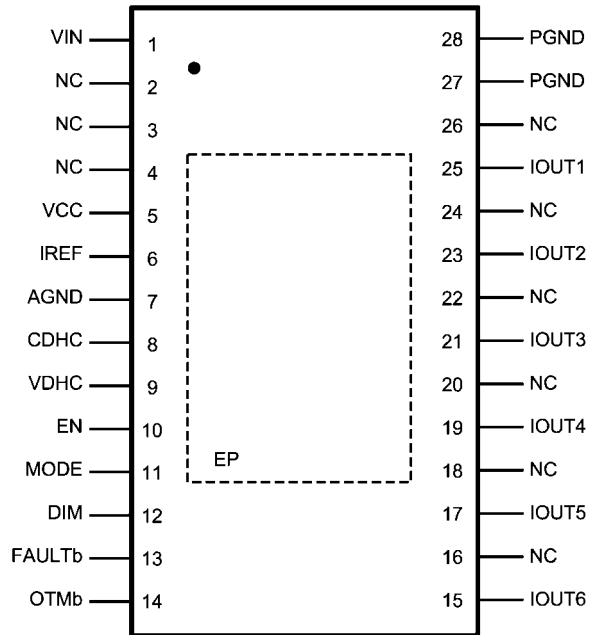

**Top View**  
**28 Lead Plastic eTSSOP-28**  
**NS Package Number MXA28A**

30006431

## Ordering Information

Part Number	Package Type	NS Package Drawing	Supplied As
<b>For LM3432</b>			
LM3432SQ	LLP-24	SQA24B	1000 Units on Tape and Reel
LM3432SQX			4500 Units on Tape and Reel
LM3432SQE			250 Units on Tape and Reel
LM3432MH	eTSSOP-28	MXA28A	Rail of 48 Units
LM3432MHX			2500 Units on Tape and Reel
<b>For LM3432B</b>			
LM3432BSQ	LLP-24	SQA24B	1000 Units on Tape and Reel
LM3432BSQX			4500 Units on Tape and Reel
LM3432BSQE			250 Units on Tape and Reel

## Pin Descriptions

Pin Number		Name	Description
LLP-24	eTSSOP-28		
1	5	VCC	Internal linear regulator output, needs 680nF minimum for stability.
2	6	IREF	I <sub>OUT</sub> current setting pin. An external resistor is used to program the string current.
3	7	AGND	Analog ground
4	8	CDHC	An external capacitor to ground programs the Dynamic Headroom Control (DHC) response time constant.
5	9	VDHC	DHC voltage output. Connecting this output through a gain setting resistor to the DHC pin of National Semiconductor's LM3430 enables the DHC function.
6	10	EN	Device Enable, active HIGH.
7	11	MODE	Dimming mode select pin. Short to ground for Digital PWM dimming or connect to an external capacitor to ground for analog dimming.
8	12	DIM	Digital PWM or Analog voltage input for IOU <sub>T</sub> duty cycle.
9	13	FAULT <sub>b</sub>	Open drain active LOW output for output fault.
10	14	OTM <sub>b</sub>	Open drain active LOW over temperature warning output.
12,13,15,17,19,20	15, 17, 19, 21, 23, 25	IOU <sub>T</sub> 1-6	Constant current sink outputs, adjustable 15mA to 40mA, voltage across this pin can be up to 80V max.
22	27, 28	PGND	Power Ground.
24	1	VIN	Supply voltage input, from 6V to 40V.
11,14,16,18,21,23	2, 3, 4, 16, 18, 20, 22, 24, 26	NC	No connection and should be left open.
EP	EP	EP	Thermal connection pad, connect directly to GND.

## Absolute Maximum Ratings (Notes 1, 6)

If Military/Aerospace specified devices are required, please contact the National Semiconductor Sales Office/ Distributors for availability and specifications.

VIN Voltage	-0.3V to 42V
IREF Voltage	-0.3V to 7V
IOUT1 through IOUT6 Voltage	-0.3V to 82V
VCC Voltage	-0.3V to 7V
EN Voltage	-0.3V to 7V
FAULTb, OTMb Voltage	-0.3V to 7V
MODE Voltage	-0.3V to 7V
PWM Voltage	-0.3V to 7V
VDHC Voltage	-0.3V to 7V
CDHC Voltage	-0.3V to 7V

## ESD Susceptibility (Note 2)

Human Body Model	2.0kV
Lead Temperature	
Vapor Phase (60 sec.)	215°C
Infra-red (15 sec.)	220°C
Maximum Junction Temp.	150°C

## Operating Ranges (Note 1)

Supply Voltage, VIN	6 to 40V
IOUT1 through IOUT6 Voltage	0 to 80V
Operating Junction Temp.	-40°C to +125°C
Storage Temperature	-65°C to +150°C
Thermal Resistance, $\theta_{JA}$ (Note 3)	
LLP-24	33.2°C/W
eTSSOP-28	29°C/W

**Electrical Characteristics** Limits in standard type are for  $T_j = 25^\circ\text{C}$  only; limits in **boldface type** apply over the junction temperature ( $T_j$ ) range of  $-40^\circ\text{C}$  to  $+125^\circ\text{C}$ . Minimum and Maximum limits are guaranteed through test, design, or statistical correlation.  $V_{IN} = 18\text{V}$ ,  $R_{IREF} = 54.7\text{ k}\Omega$ ,  $V_{EN} = 5\text{V}$ ,  $V_{MODE} = 0\text{V}$ ,  $V_{DIM} = 5\text{V}$  and  $V_{OUT1-6} = 1.2\text{V}$  unless otherwise indicated (Note 4). Parameter limits apply to both the LM3432 and LM3432B unless otherwise indicated.

Symbol	Parameter	Conditions	Min	Typ	Max	Units
<b>Input Characteristics</b>						
$I_{SHDN}$	Shutdown Input Supply Current	EN = 0V, DIM = 0V		40	<b>90</b>	$\mu\text{A}$
$I_Q$	Quiescent Current from VIN			2.25	<b>2.65</b>	mA
$V_{EN}$	Enable Threshold Voltage	$V_{EN}$ rising	<b>1.48</b>	1.75	<b>2</b>	V
$V_{EN\_HYST}$	Enable Threshold Hysteresis			0.4		V
$I_{EN}$	Enable pin Pull-up Current	EN = 0V		0.5		$\mu\text{A}$
		EN = 2V		5		
<b>VCC Regulator</b>						
$V_{CCreg}$	VCC Regulated Output		<b>4.7</b>	5	<b>5.25</b>	V
$V_{CCreg\_1}$	VCC Regulated Output at Max. VIN	$V_{IN} = 40\text{V}$	<b>4.7</b>	5	<b>5.25</b>	V
$V_{CCreg\_2}$	VCC Regulated Output at Min. VIN	$V_{IN} = 6\text{V}$ , $I_{VCC} = 2\text{mA}$		4.8		V
$I_{VCC\_SC}$	VCC Short-Circuit Current	$V_{IN} = 6\text{V}$ , $V_{CC} = 0\text{V}$		9		mA
$V_{CCUVLO}$	VCC UVLO Upper Threshold	VCC rising	<b>3.9</b>	4.15	<b>4.4</b>	V
$V_{CCUVLO\_HYST}$	VCC UVLO Hysteresis			0.375		V
<b>Analog PWM control</b>						
$I_{MODE}$	MODE pin Output Current	MODE = 2V		34		$\mu\text{A}$
$V_{MODE\_PK}$	MODE pin Peak Voltage	$C_{MODE} = 5.6\text{nF}$		3.1		V
$V_{MODE\_VA}$	MODE pin Valley Voltage	$C_{MODE} = 5.6\text{nF}$		1.0		V
<b>Digital PWM control</b>						
$V_{PWM\_HIGH}$	PWM Voltage HIGH	MODE = GND	<b>1.7</b>			V
$V_{PWM\_LOW}$	PWM Voltage LOW	MODE = GND			<b>1</b>	V
<b>Dynamic Headroom Control Output</b>						
$V_{DHC\_MAX}$	VDHC pin Max. Output Voltage	$I_{VDHC} = 2\text{mA}$	<b>2</b>	2.5		V
$I_{VDHC\_MAX}$	VDHC pin Max. Output Current	$V_{DHC} = 1.2\text{V}$	<b>5</b>	9		mA
$V_{DHC\_REG\_20}$	VDHC Regulation at 20mA	$R_{IREF} = 54.7\text{k}$ , $C_{DHC} = 100\text{nF}$		0.625		V
$V_{DHC\_REG\_40}$	VDHC Regulation at 40mA	$R_{IREF} = 27.5\text{k}$ , $C_{DHC} = 100\text{nF}$		1.25		V

Symbol	Parameter	Conditions	Min	Typ	Max	Units
<b>Switching Characteristics</b>						
$t_{pd\_H}$	IOUT Rising Edge Phase Delay	MODE = GND, Pulsing PWM 10 $\mu$ s		500		ns
$T_r$	IOUT Rise Time	MODE = GND, rising edge from 10% to 90% of IOUT		25		ns
<b>Output Current</b>						
$V_{IREF}$	IREF pin Voltage	$6V \leq V_{IN} \leq 40V$	<b>1.215</b>	1.245	<b>1.27</b>	V
$I_{OUT20}$	Constant Current Sink of 20mA	$R_{IREF} = 54.7k, V_{IOUT1-6} = 1.1V$	18.85 <b>18.5</b>	20	21.05 <b>21.4</b>	mA
$I_{OUT40}$	Constant Current Sink of 40mA	$R_{IREF} = 27.5k, V_{IOUT1-6} = 1.6V$	37.9 <b>37.3</b>	40	41.55 <b>42.15</b>	mA
$I_{OUT20\_match}$	Output Current Matching of $I_{OUT20}$ (Note 5)	$6V \leq V_{IN} \leq 40V$			<b>2.25</b>	%
$I_{OUT40\_match}$	Output Current Matching of $I_{OUT40}$ (Note 5)	$6V \leq V_{IN} \leq 40V$			<b>2</b>	%
$I_{OUT\_max}$	Maximum Output Current, IREF shorted to GND.	$V_{IREF} = 0V, V_{IOUT} = 4.5V$	<b>50</b>	80	<b>110</b>	mA
$V_{DROD\_IOUT20}$	Dropout Voltage of $I_{OUT20}$ (Note 7)	$R_{IREF} = 54.7k$		0.3	<b>0.525</b>	V
$V_{DROD\_IOUT40}$	Dropout Voltage of $I_{OUT40}$ (Note 7)	$R_{IREF} = 27.5k$		0.6	<b>1.125</b>	V
$I_{OUT\_OFF}$	Output Current when EN is LOW	EN = 0, $V_{OUT} = 80V$		0.025	3	$\mu$ A
<b>Fault Detection</b>						
$V_{SHORTFAULT}$	$V_{IOUT}$ Short Fault Threshold	FAULTb goes LOW during $V_{IOUT}$ rising, other $V_{IOUTs} = 1.0V$	<b>7.3</b>	7.9	<b>8.8</b>	V
$t_{D\_SHORTFAULT}$	Short Fault Delay	$V_{IOUT}$ set to 10V, FAULTb goes LOW, other $V_{IOUTs} = 1.0V$		150		$\mu$ s
$t_{D\_OPENFAULT}$	Open Fault Delay (LM3432 only)	$V_{IOUTX}$ set open, FAULTb goes LOW		50		$\mu$ s
$V_{FAULT\_LOW}$	FAULTb and OTMb LOW	5mA into FAULTb			<b>0.7</b>	V
$I_{LEAK\_FAULT}$	FAULTb and OTMb Open Leakage	$V_{FAULTb} = V_{OTMb} = 5V$		0.005	<b>1</b>	$\mu$ A
<b>Thermal Protection</b>						
OTM	Over Temperature Monitor Threshold			125		$^{\circ}$ C
OTM <sub>HYST</sub>	Over Temperature Monitor Hysteresis			20		$^{\circ}$ C
T <sub>SD</sub>	Thermal Shutdown Threshold			165		$^{\circ}$ C
T <sub>SDHYST</sub>	Thermal Shutdown Hysteresis			20		$^{\circ}$ C

**Note 1:** Absolute Maximum Ratings are limits beyond which damage to the device may occur. The Recommended Operating Limits define the conditions within which the device is intended to be functional. For guaranteed specifications and test conditions, see the Electrical Characteristics.

**Note 2:** The human body model is a 100 pF capacitor discharged through a 1.5k $\Omega$  resistor into each pin.

**Note 3:** The maximum allowable power dissipation is a function of the maximum junction temperature,  $T_{J\_MAX}$ , the junction-to-ambient thermal resistance,  $\theta_{JA}$  and the ambient temperature,  $T_A$ . The maximum allowable power dissipation at any ambient temperature is calculated using:  $P_{D\_MAX} = (T_{J\_MAX} - T_A) / \theta_{JA}$ . Exceeding the maximum allowable power dissipation will cause excessive die temperature.

**Note 4:** All limits are guaranteed at room temperature (standard type face) and at **temperature extremes (bold type face)**. All room temperature limits are 100% tested. All limits at **temperature extremes** are guaranteed via correlation using standard Statistical Quality Control (SQC) methods. All limits are used to calculate Average Outgoing Quality Level (AOQL). Typical values represent the most likely parametric norm at  $T_j = 25^{\circ}$ C and are provided for reference purposes only.

**Note 5:**  $I_{OUT\_match}$  is the greatest percentage delta between output string currents with respect to the median.

$$I_{OUT\_match} = \frac{1}{2} \left( \frac{\text{Max}(I_{OUTX}) - \text{Min}(I_{OUTX})}{\text{Median}} \right) \times 100\% \text{ and}$$

$$\text{Median} = \frac{\text{Max}(I_{OUTX}) + \text{Min}(I_{OUTX})}{2}$$

**Note 6:** Rating limits apply to both the LM3432 and LM3432B.

**Note 7:** Dropout voltage is defined as the IOUT pin to GND voltage at which the output current sink drops 10% from the nominal value.

**Typical Performance Characteristics** Unless otherwise specified, the following conditions apply:  $V_{IN} = 18V$ ,  $R_{IREF} = 54.7\text{ k}\Omega$ ,  $V_{EN} = 5V$ ,  $V_{MODE} = 0V$ ,  $V_{DIM} = 5V$  and  $V_{OUT1-6} = 1.2V$ . Typical performance characteristics are valid for both the LM3432 and LM3432B unless otherwise indicated.

**Quiescent Current vs Supply Voltage**

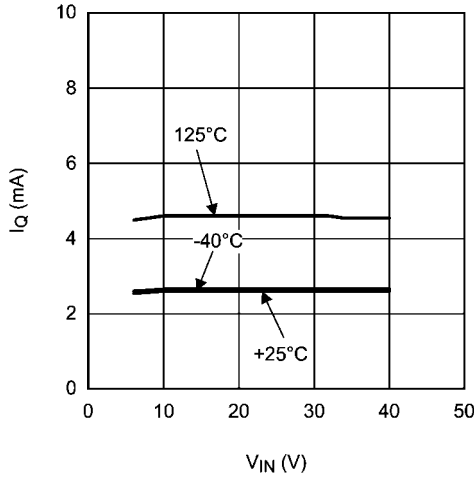

30006403

**Shutdown Current vs Supply Voltage**

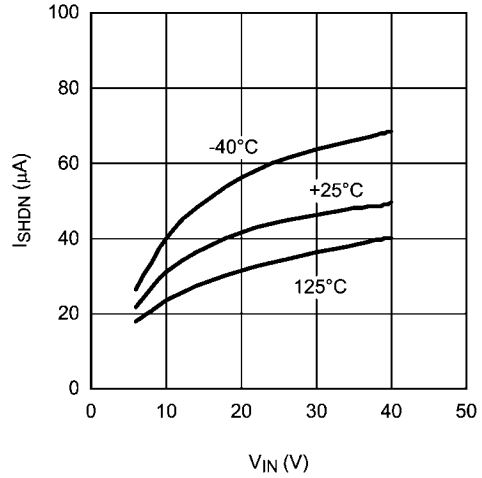

30006404

**VCC Regulator Output vs Supply Voltage**

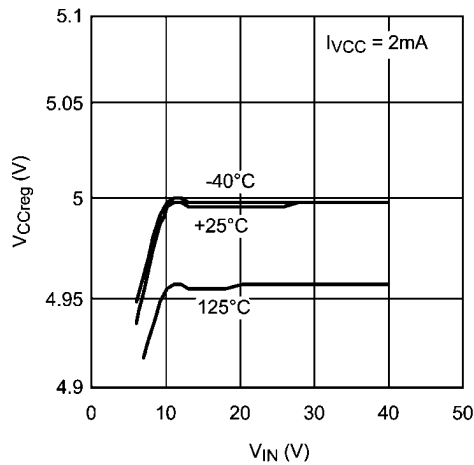

30006405

**Current Setting Reference Voltage vs Supply Voltage**

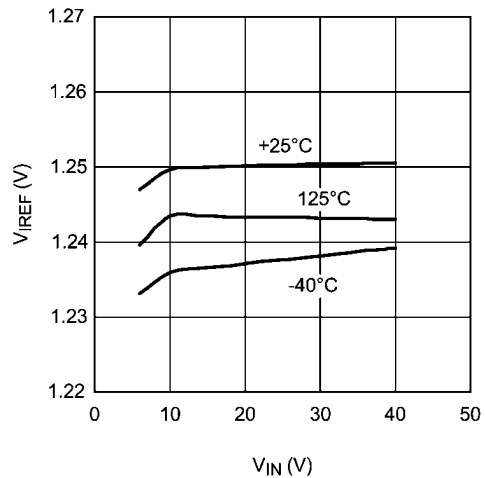

30006406

**Average String Current vs Current Setting Resistance**

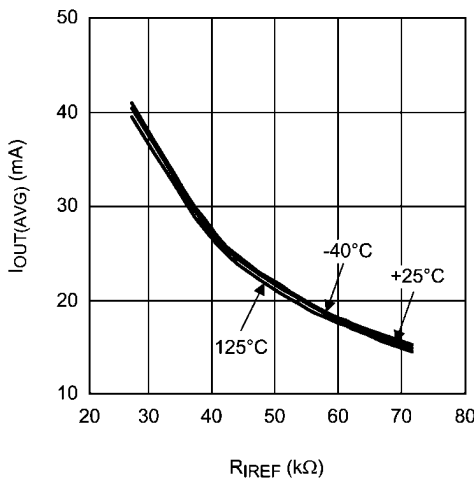

30006407

**Output Current Matching vs Temperature**

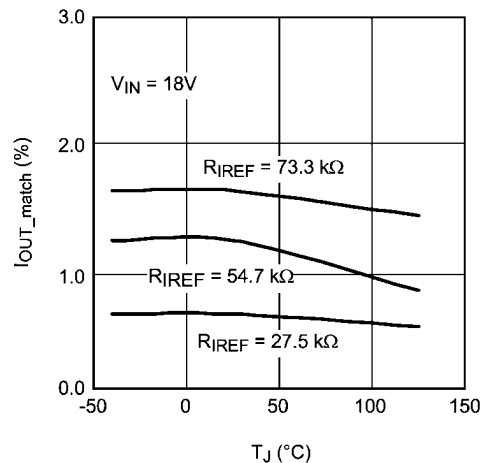

30006408



**PWM Dimming Frequency vs  $C_{MODE}$**

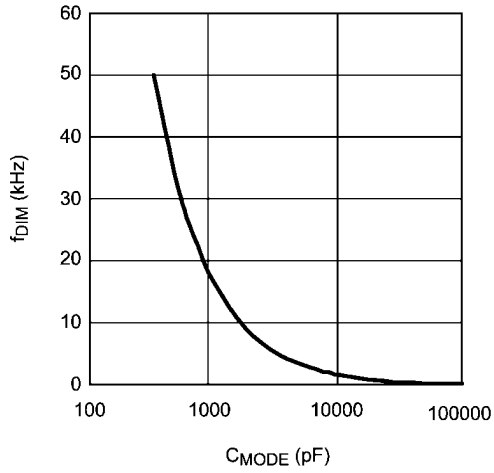

30006409

**PWM Digital Dimming Operation (Channel 1 Waveform)**

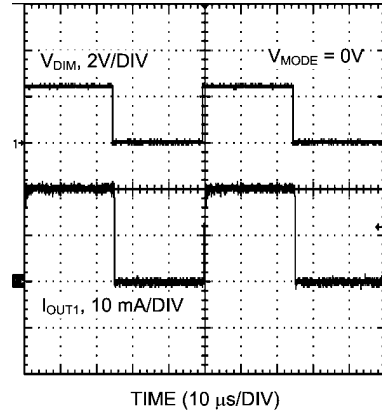

30006410

**PWM Dimming Characteristic, Rising Edge (Channel 1 Waveform)**

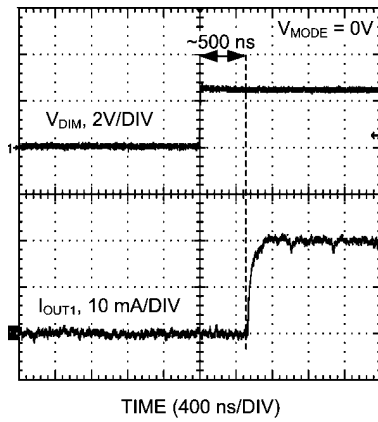

30006411

**PWM Dimming Characteristic, Falling Edge (Channel 1 Waveform)**

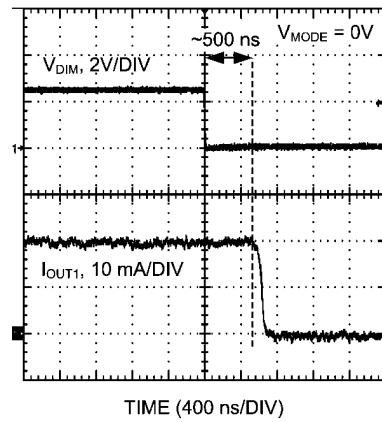

30006412

**Analog Dimming Operation**

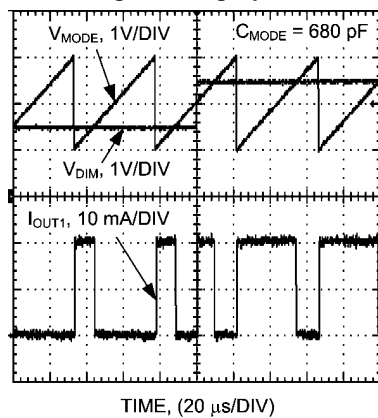

30006413

# Simplified Functional Block Diagram

LM3432/LM3432B

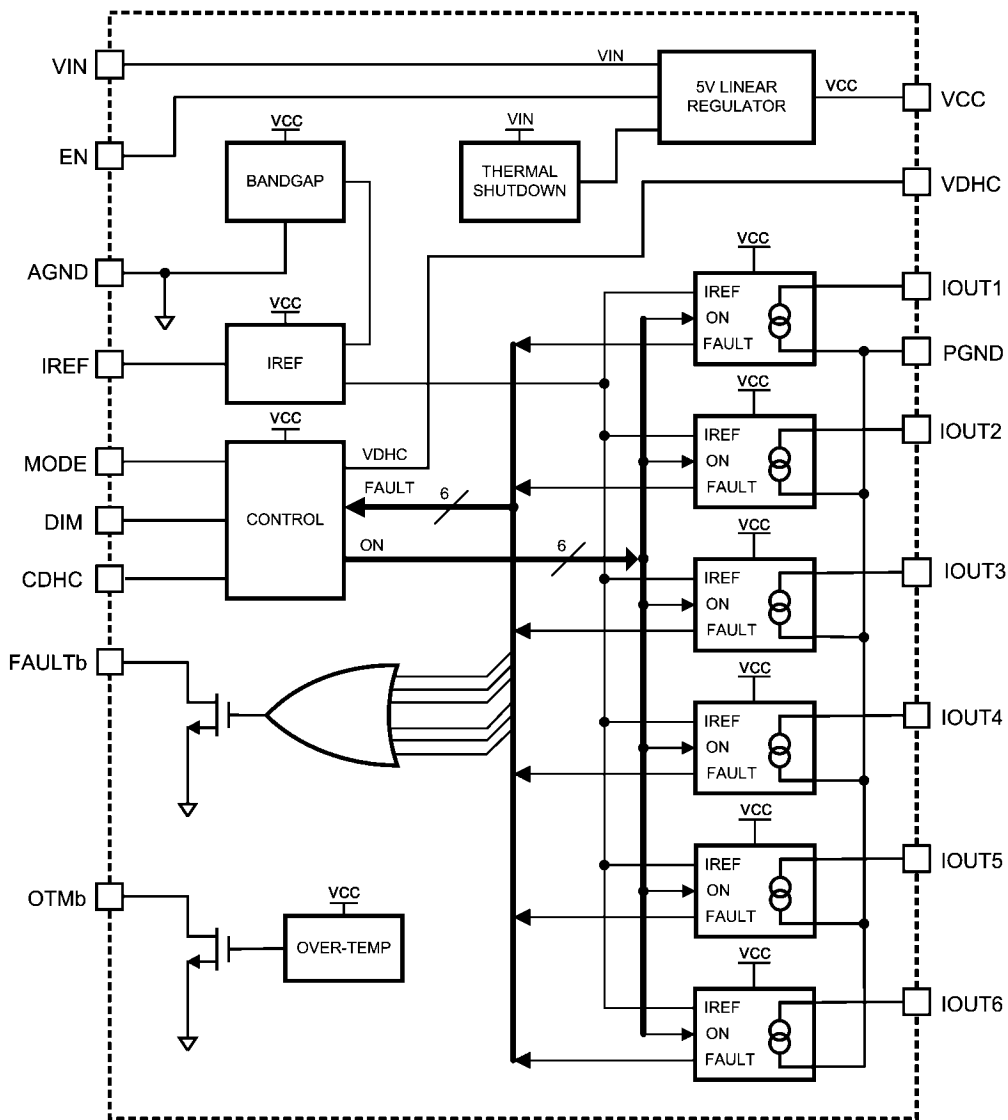

30006415

## Functional Description

### OVERVIEW

The LM3432/LM3432B are 6-channel high voltage current regulators for LED backlight applications which incorporates individual channel current regulators to give accurate current sinking for each LED string. String to string tolerance is kept within  $\pm 2.0\%$  at 40 mA and  $\pm 2.25\%$  at 20 mA. The 6-channels current sinks can be adjusted from 15 mA to 40 mA by an external resistor. Channel outputs can withstand up to 80V. Channel 5 or 6 output can be disabled by shorting the selected output pin to ground prior to power-up. Both the digital PWM dimming signal and analog voltage signal can be used to control the duty cycle of all the six channels. The LM3432/LM3432B also provide fault indications to the system MCU for an LED open (included in the LM3432 only) or short circuit or an over-temperature condition.

### INTERNAL 5V LINEAR REGULATOR

An internal 5V linear regulator with an Under-Voltage Lock-Out (UVLO) function is integrated within the LM3432/LM3432B. This regulated 5V is used for internal circuitry and can support a small amount of external loading, not to exceed 2 mA when  $V_{IN} = 6V$ . The supply input pin ( $V_{IN}$ ) can be connected directly to an input voltage up to 40V, with transient capability up to 42V. The VCC output regulates at 5V and its current limited to 9 mA. To ensure stable operation, the external capacitor  $C_{VCC}$  must be at least 680 nF with 1  $\mu F$  recommended. If the voltage at the VCC pin drops below the UVLO threshold of 3.8V, the device will shut down the output channels and other functional blocks. Normal operation will be resumed once the  $V_{CC}$  voltage is allowed to rise above the UVLO rising threshold of 4.15V.

### BANDGAP VOLTAGE REFERENCE

A precision reference voltage is required for accurate control of the output currents. The LM3432/LM3432B contain a bandgap voltage reference block that provides a high precision reference voltage for internal operation. The bandgap reference voltage is typically trimmed to 1.245V.

### OUTPUT CURRENT REGULATOR (IOUT1 to IOUT6)

The LM3432/LM3432B contains six individual integrated current regulators to give accurate current sinking for each LED string. String to string tolerance is kept within  $\pm 2.0\%$  at 40 mA and  $\pm 2.25\%$  at 20 mA. The sink current level is adjusted by an external resistor,  $R_{IREF}$  in the range of 15 mA to 40 mA. The IOUT pins can withstand up to 80V. The ability to withstand high voltage enables the user to add more LEDs in a single string. The calculation of  $I_{OUT}$  with respect to  $R_{IREF}$  is shown below.

$$I_{OUT} = \frac{1.094}{R_{IREF}} \times 10^6 \text{ where } I_{OUT} \text{ is in mA}$$

Channels 5 and 6 are designed to be user disabled without activating the fault detection circuitry. With this feature, the user can readily configure the device to a 4, 5 or 6 channel driver. In order to disable a channel, the IOUT5 and/or IOUT6 pin(s) must be tied to ground before powering up the device. During power-up, channels 5 and 6 will be checked and any grounded channel(s) will be automatically disabled. The disabled status will remain until either power is recycled or the enable (EN) pin is toggled.

### ANALOG DIMMING OF LED STRINGS

Dimming of LED brightness is achieved by Pulse Width Modulation (PWM) control of the string currents. The LM3432/LM3432B accepts both analog voltage and PWM digital dimming input signals for this feature. With a capacitor ( $C_{MODE}$ ) connected across the MODE pin and ground, the device will monitor the voltage level at the DIM pin and generate the required PWM control signal internally. The internal implementation of the LM3432/LM3432B's dimming function is illustrated in Figure 1.

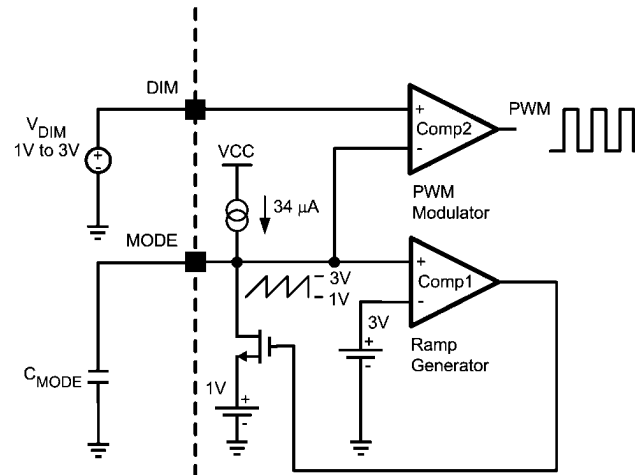

30006417

FIGURE 1. Analog Dimming of LEDs

An internal current source of 34  $\mu A$  (typical) will charge the external capacitor ( $C_{MODE}$ ) linearly until it reaches 3V. The comparator (Comp1) then forces  $C_{MODE}$  to be discharged to 1V very quickly. By repeating the cycle, a saw-tooth waveform as shown in Figure 1 is generated. Comparator (Comp2) compares this ramp waveform with the external dc voltage at the DIM pin generating the desired PWM control signal.

When  $V_{DIM} \leq 1V$ , ON duty factor,  $D_{ON} = 0\%$  and when  $V_{DIM} \geq 3V$ ,  $D_{ON} = 100\%$ . The frequency of the PWM control signal can be calculated as shown below.

$$f_{PWM} = \frac{1.65 \times 10^{-5}}{C_{MODE}} \text{ where } f_{PWM} \text{ is in Hz}$$

Or

$$C_{MODE} = \frac{1.65 \times 10^{-5}}{f_{PWM}} \text{ where } C_{MODE} \text{ is in Farads}$$

### PWM DIGITAL DIMMING of LED STRINGS

Alternatively, the dimming control can be implemented by direct application of a digital signal to the device. With the MODE pin connected to ground, an externally applied PWM dimming signal is applied to the DIM pin. The peak amplitude of the externally applied PWM signal should be greater than 1.5V to guarantee clean PWM switching.

During PWM dimming, channels are not switched simultaneously in an effort to minimize large surge currents from being drawn from the LED supply rail. Each channel will have 0.5  $\mu s$  phase delay with respect to the preceding channel. As a consequence of the phase delay, for a control pulse width less

than  $0.5 \mu\text{s}$ , the duty cycle will be rounded down to 0% and for a control pulse width less than  $0.5 \mu\text{s}$  off time, the duty cycle will be rounded up to 100%. Therefore,  $0.5 \mu\text{s}$  becomes

the finest pulse width resolution that can be realized. The PWM switching timing for all six channels is shown in *Figure 2*.

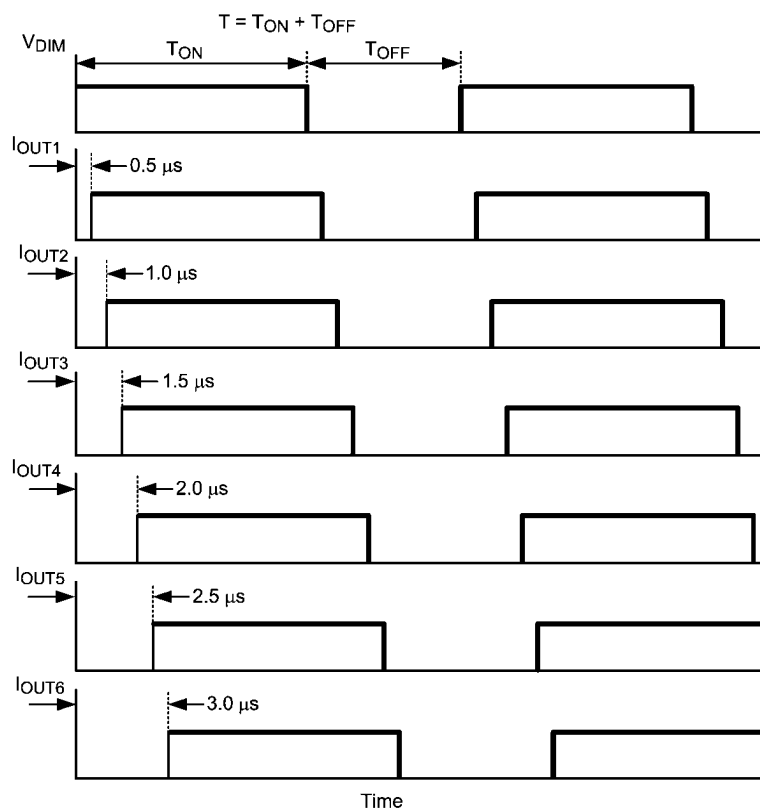

30006420

**FIGURE 2. PWM Dimming Switching Timing**

## LED SHORT FAULT DETECT

### With DHC

If the Dynamic Headroom Control (DHC) feature is used, the lowest voltage between the IOUT pins and ground among the strings will be regulated to  $0.625V$  typical ( $I_{LED} = 20 \text{ mA}$ ) by lowering the LED supply rail voltage,  $V_{LED}$ . If an LED short fault condition occurs and causes the voltage between any of the IOUT pins and ground to exceed the typical short fault threshold of  $7.9V$  for more than  $150 \mu\text{s}$ , the affected channel(s) will be latched off and the FAULTb pin will be pulled to ground. The affected channel(s) will remain latched off until recycling power or toggling the EN pin. All of the other channels that are not affected will continue to function normally.

### Without DHC

In applications where the DHC function is not used, the IOUT pin voltage on each string will be the voltage difference between the LED supply rail voltage,  $V_{LED}$ , and the voltage drop across the entire LED string. If the voltage between any of the IOUT pins and ground is less than  $2V$  typical, the short fault

detect feature will be active for all channels. In the event an LED short fault condition occurs and causes the voltage between any of the IOUT pin and ground to exceed the typical short fault threshold of  $7.9V$  for more than  $150 \mu\text{s}$ , the affected channel(s) will be latched off and the FAULTb pin will be pulled to ground. The affected channel(s) will remain latched off until recycling power or toggling the EN pin. All of the other channels that are not affected will continue to function normally. If the voltages between all IOUT pins and ground are greater than  $2V$  typical, the Short Fault Detect feature will be disabled to prevent false triggering of the short fault detect function.

### LED OPEN FAULT DETECT (LM3432 ONLY)

For the LM3432, if an open fault should occur and the affected channel sinks no current for greater than  $50 \mu\text{s}$ , it will be latched off (until recycling power or toggling EN pin). The FAULTb pin's output will be pulled to ground while the other channels keep functioning normally. The open fault detection and FAULTb indication features are inactive in the LM3432B.

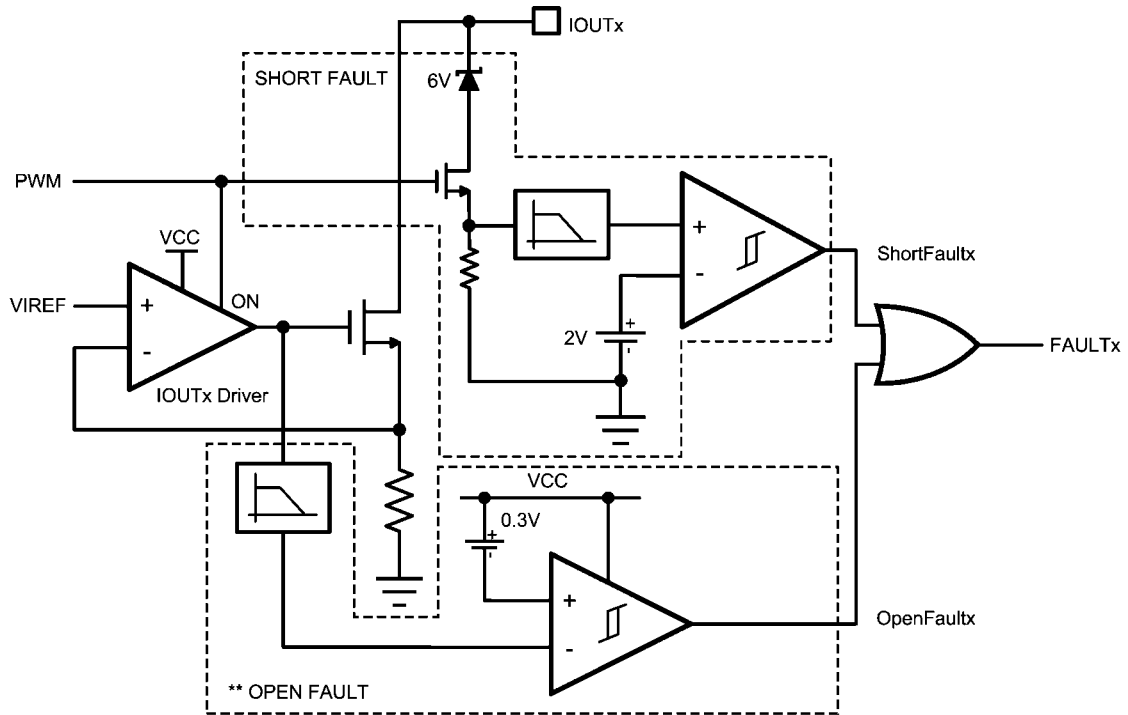

\*\* Open fault protection and indication are not available in the LM3432B

30006429

**FIGURE 3. Fault Detect Functional Block Diagram**

#### OVER-TEMPERATURE MONITOR

If the LM3432/LM3432B junction temperature exceeds approximately 125°C, the OTMb pin will be pulled to ground but the part will continue to function. Action must be taken to lower the temperature at this point. The PWM duty factor may be lowered as an example to reduce the amount of heat generated, which will in turn lower the die temperature. If the junction temperature is allowed to rise beyond approximately 165°C, the part will shut down. When the device is cooled down to about 145°C, device operation will resume.

Note that this thermal shutdown protection is only intended as a fault mode protection feature. Device operation above rated maximum operating junction temperature is neither recommended nor guaranteed.

#### DYNAMIC HEADROOM CONTROL

To use the DHC function, connect a gain setting resistor from the VDHC pin of the LM3432/LM3432B to the VDHC pin of the LM3430 (National Semiconductor's Boost Controller for LED Backlighting) that is supplying power to the LED rails. The LM3432/LM3432B's DHC function will regulate the voltage between the IOUT pins and ground to a minimum of 0.625V typical (IOUT = 20 mA) to optimize overall efficiency. A large DHC time constant needs to be set in order not to interfere with the loop response of the DC-DC converter. This can be implemented by connecting a capacitor from the LM3432/LM3432B's CDHC pin to ground. If the DHC function is not needed, leave the VDHC pin floating. When operated in this manner, if the lowest voltage between any of the IOUT pins and ground is greater than 2V, the LED short fault detection function will be disabled. For the LM3432B, if any open condition occurs on any channels, the DHC function will be inactive and the LED supply rail voltage from the LM3430 will stay at its preset level. If the excess headroom voltage is greater than the short fault detect threshold, 7.3V(min), the device may latch off the LED string(s) due to short fault protection. In order to insure the proper operation of good LED strings, designers must design for sufficient excess headroom voltage below the short fault detect threshold.

## Applications Information

The LM3432/LM3432B provide a simple and handy solution for LED driving. With only a few external passive components,

an LED panel of up to about 120 white LEDs can be illuminated. A typical application configuration driving six strings with twelve white LEDs per string is shown in *Figure 4*.

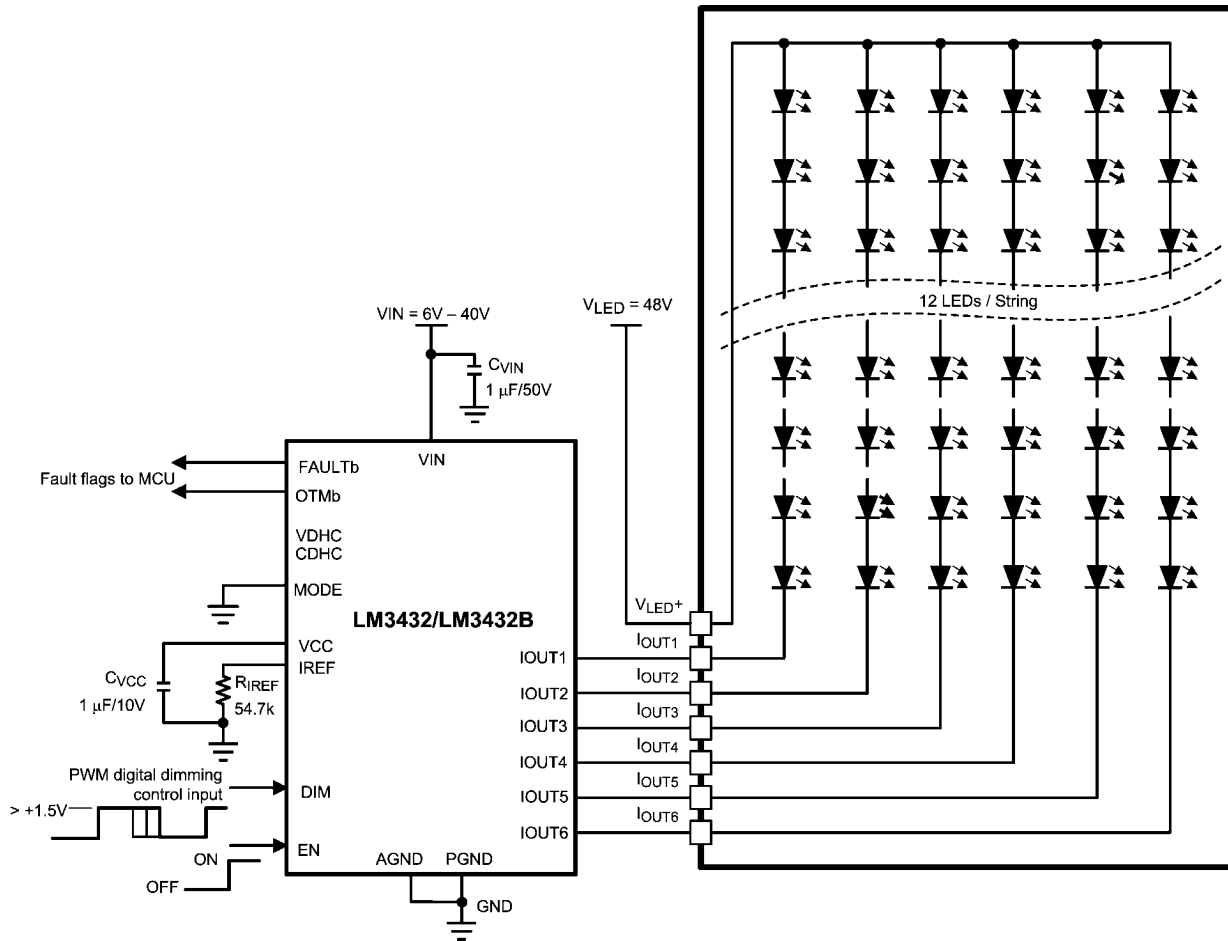

30006421

**FIGURE 4. Typical Application Schematic to Drive 72 White LEDs (@20 mA) (PWM Digital Dimming)**

### DETERMINATION OF EXTERNAL COMPONENTS

The typical application only requires three external components. The selection of those components is described in detail below.

#### Programming of String Current, IOUT1 to IOUT6

The string current can be programmed by an external resistor,  $R_{IREF}$ . The equation to calculate the resistance of this resistor is shown below.

$$R_{IREF} = \frac{1.094}{I_{OUT}} \text{ in } k\Omega$$

In order to ensure good current regulation over the full operating temperature range, a high quality resistor with  $\pm 1\%$  tolerance and a low temperature coefficient is recommended.

For the example shown in *Figure 4*, the string current is 20 mA. Applying to the equation:

$$R_{IREF} = \frac{1.094}{20 \text{ mA}} = 54.7 \text{ k}\Omega$$

#### Selecting the VCC Output Capacitor, $C_{VCC}$

For proper operation, a VCC output capacitor ( $C_{VCC}$ ) of at least 680 nF is required for stability reason. The recommended  $C_{VCC}$  capacitance is 1  $\mu$ F.

### Selecting the VIN Capacitor, C<sub>VIN</sub>

The purpose of this capacitor is to supply transient current to the device and suppress VIN noise in order to ensure proper operation. A low ESR ceramic capacitor with good high frequency performance is recommended. The capacitance can range from 0.1  $\mu$ F to 1  $\mu$ F.

### Analog Dimming Control

If analog dimming control is required, a capacitor, C<sub>MODE</sub> should be connected from the MODE pin to ground instead of shorting the MODE pin to ground. The relationship between the PWM dimming frequency and the capacitance of C<sub>MODE</sub> is illustrated below.

$$f_{\text{PWM}} = \frac{1.65 \times 10^{-5}}{C_{\text{MODE}}} \text{ where } C_{\text{MODE}} \text{ is in Farads and } f_{\text{PWM}} \text{ is in Hz}$$

When  $V_{\text{PWM}} \leq 1\text{V}$ ,  $D_{\text{ON}} = 0\%$  and when  $V_{\text{PWM}} \geq 3\text{V}$ ,  $D_{\text{ON}} = 100\%$

The LED dimming ratio is calculated from the ratio of minimum ON duty factor to the maximum ON duty factor. With the LM3432/LM3432B, the LEDs can be fully turned on up to 100% ON duty factor and the minimum ON duty factor is limited by the phase delay time, 0.5  $\mu$ s. The dimming ratio can be estimated as below.

$$\text{Dimming Ratio} = \frac{1}{5 \times 10^{-7} f_{\text{PWM}}} : 1$$

As an example, if the PWM dimming frequency is set to 500 Hz, the best achievable dimming ratio is:

$$\text{Dimming Ratio (} f_{\text{PWM}} = 500 \text{ Hz)} = \frac{1}{5 \times 10^{-7} \times 500} : 1 = 4000 : 1$$

### Driving High Current LEDs

The LM3432/LM3432B can support string currents from 15 mA to 40 mA. If the application needs to drive high current LEDs that require more than 40 mA per string, the LM3432/LM3432B provides the alternative of connecting several IOUT ports together to achieve higher output current per string. With this approach, there is the obvious trade off between higher output current and number of strings driven. Two possible configurations are illustrated in *Figure 5*.

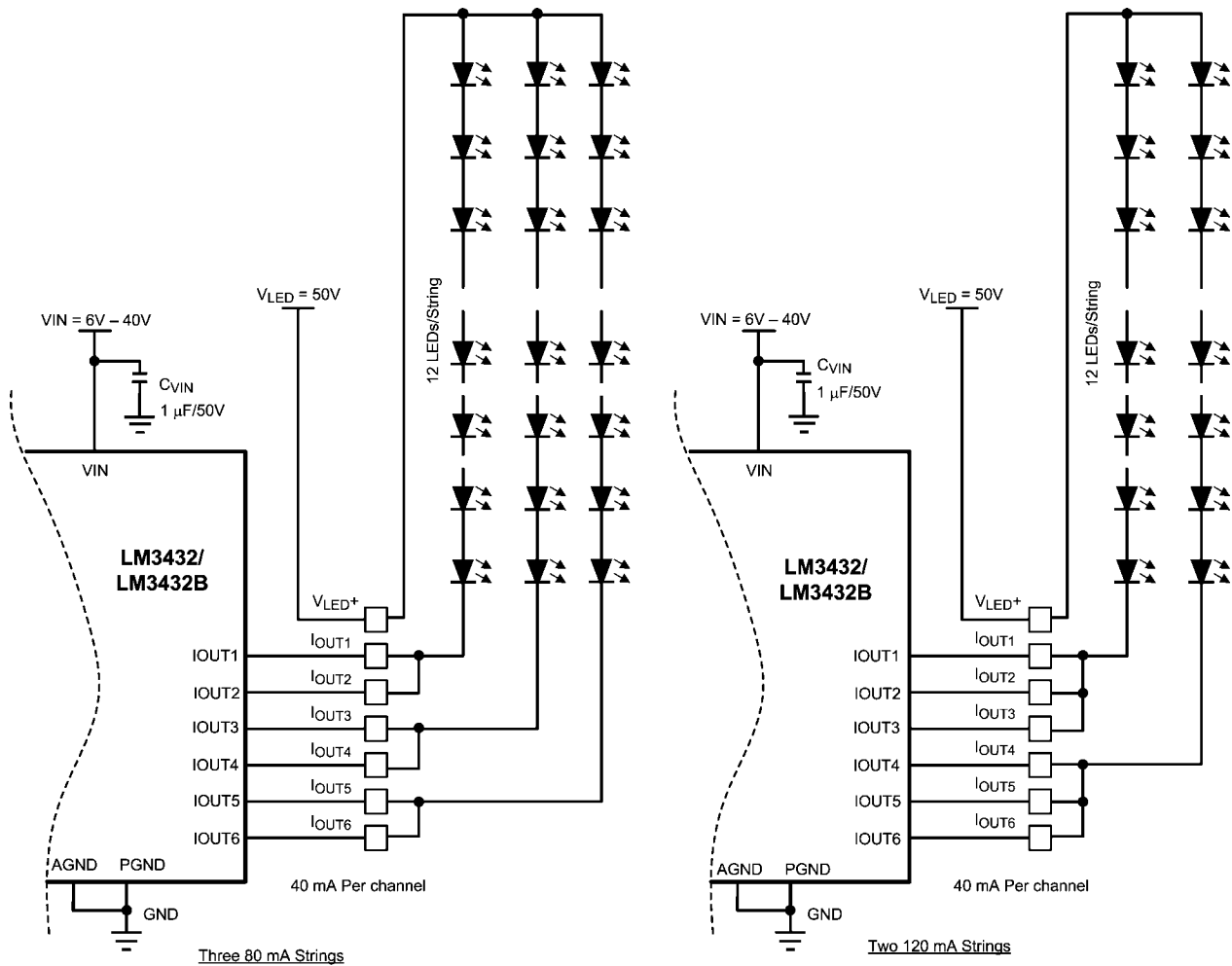

30006427

FIGURE 5. Achieving Higher LED String Current by Grouping IOOUT Ports

#### Dynamic Headroom Control, DHC with LM3430

When the LM3432/LM3432B are powered with National Semiconductor's Boost Controller for LED Backlighting, LM3430, the Dynamic Headroom Control (DHC) feature helps to provide the optimal system efficiency. By connecting VDHC through a gain setting resistor to the DHC pin of the LM3430 that is supplying the LED power rail, the LM3432/LM3432B's DHC function will regulate the minimum of the ON voltage of the six channels to 0.625V typical ( $I_{OUT} = 20$  mA). This is the minimum voltage headroom required at outputs to keep the current regulator in its linear operating range. In order not to interfere with the feedback loop response of the upstream DC-DC converter, the DHC response time constant

must be set to a large enough value by adding a capacitor from CDHC pin to ground.

Figure 6 is an application schematic of a LED panel driver using both the LM3430 and the LM3432/LM3432B with the Dynamic Headroom Control function enabled. The LM3430 boosts a voltage from VIN to 50V nominal to supply the LED strings. With the DHC function disabled, the LM3430 will keep the LED string supply regulated at 50V. When the DHC is enabled, this voltage will dynamically be regulated down to a voltage that can just keep all LED string currents in regulation. That is about 40V in the application shown in Figure 6. The reduction in this rail voltage can significantly improve the overall system efficiency.



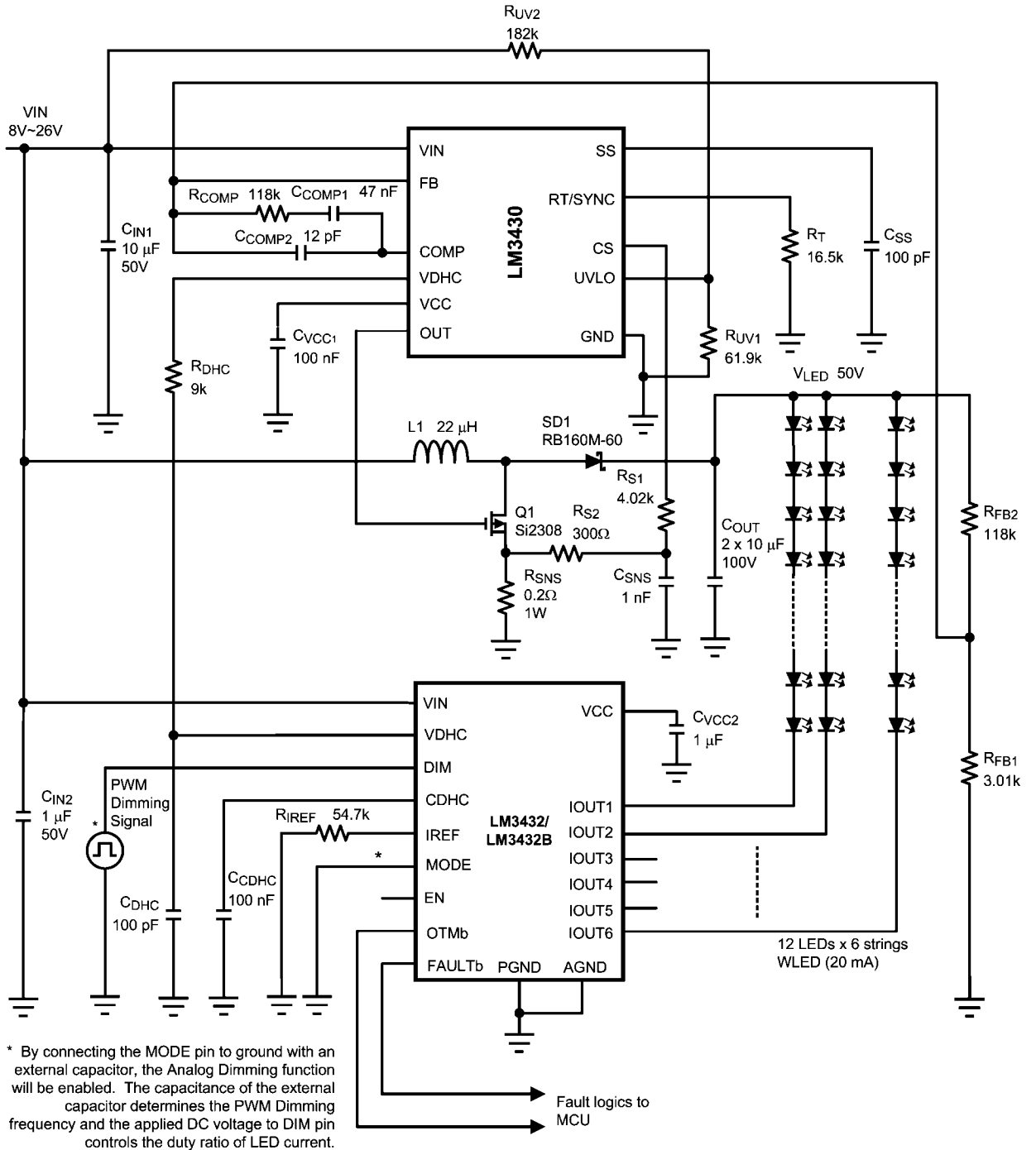

30006428

FIGURE 6. LM3430 + LM3432/LM3432B Application Schematic with Dynamic Headroom Control Enabled

**Physical Dimensions** inches (millimeters) unless otherwise noted

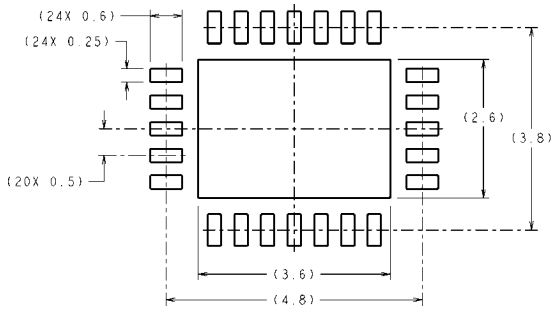

RECOMMENDED LAND PATTERN

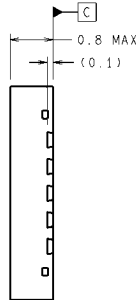
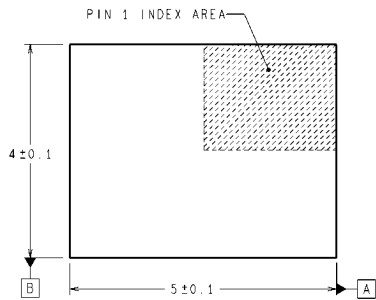

DIMENSIONS ARE IN MILLIMETERS  
DIMENSIONS IN ( ) FOR REFERENCE ONLY

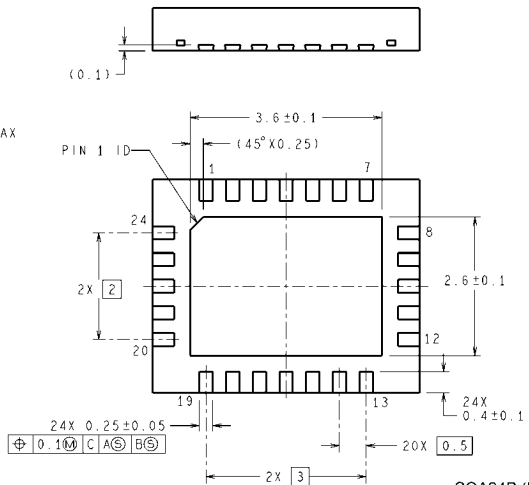

SQA24B (Rev A)

**24-Lead LLP Package**  
**NS Package Number SQA24B**

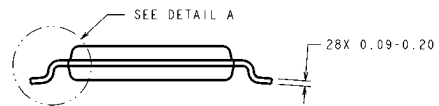
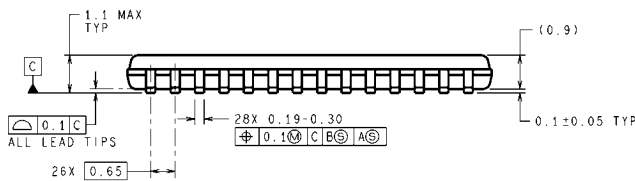
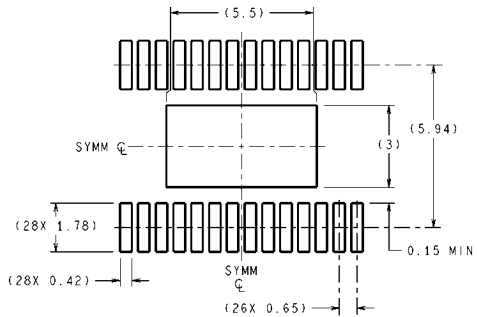
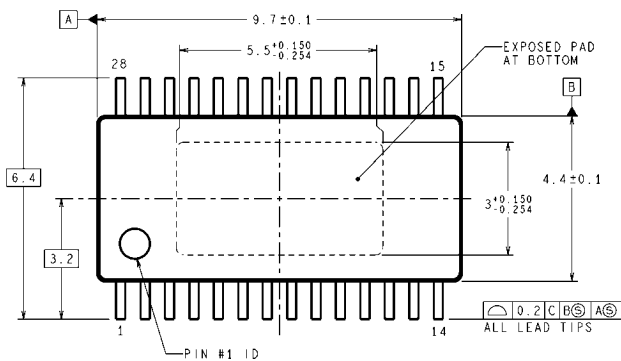

DIMENSIONS ARE IN MILLIMETERS  
DIMENSIONS IN ( ) FOR REFERENCE ONLY

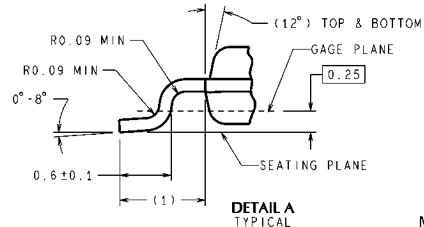

DETAIL A  
TYPICAL

MXA28A (Rev D)

**28-Lead eTSSOP Package**  
**NS Package Number MXA28A**

## Notes

For more National Semiconductor product information and proven design tools, visit the following Web sites at:

Products		Design Support	
Amplifiers	<a href="http://www.national.com/amplifiers">www.national.com/amplifiers</a>	WEBENCH	<a href="http://www.national.com/webench">www.national.com/webench</a>
Audio	<a href="http://www.national.com/audio">www.national.com/audio</a>	Analog University	<a href="http://www.national.com/AU">www.national.com/AU</a>
Clock Conditioners	<a href="http://www.national.com/timing">www.national.com/timing</a>	App Notes	<a href="http://www.national.com/appnotes">www.national.com/appnotes</a>
Data Converters	<a href="http://www.national.com/adc">www.national.com/adc</a>	Distributors	<a href="http://www.national.com/contacts">www.national.com/contacts</a>
Displays	<a href="http://www.national.com/displays">www.national.com/displays</a>	Green Compliance	<a href="http://www.national.com/quality/green">www.national.com/quality/green</a>
Ethernet	<a href="http://www.national.com/ethernet">www.national.com/ethernet</a>	Packaging	<a href="http://www.national.com/packaging">www.national.com/packaging</a>
Interface	<a href="http://www.national.com/interface">www.national.com/interface</a>	Quality and Reliability	<a href="http://www.national.com/quality">www.national.com/quality</a>
LVDS	<a href="http://www.national.com/lvds">www.national.com/lvds</a>	Reference Designs	<a href="http://www.national.com/refdesigns">www.national.com/refdesigns</a>
Power Management	<a href="http://www.national.com/power">www.national.com/power</a>	Feedback	<a href="http://www.national.com/feedback">www.national.com/feedback</a>
Switching Regulators	<a href="http://www.national.com/switchers">www.national.com/switchers</a>		
LDOs	<a href="http://www.national.com/lido">www.national.com/lido</a>		
LED Lighting	<a href="http://www.national.com/led">www.national.com/led</a>		
PowerWise	<a href="http://www.national.com/powerwise">www.national.com/powerwise</a>		
Serial Digital Interface (SDI)	<a href="http://www.national.com/sdi">www.national.com/sdi</a>		
Temperature Sensors	<a href="http://www.national.com/tempsensors">www.national.com/tempsensors</a>		
Wireless (PLL/VCO)	<a href="http://www.national.com/wireless">www.national.com/wireless</a>		

THE CONTENTS OF THIS DOCUMENT ARE PROVIDED IN CONNECTION WITH NATIONAL SEMICONDUCTOR CORPORATION ("NATIONAL") PRODUCTS. NATIONAL MAKES NO REPRESENTATIONS OR WARRANTIES WITH RESPECT TO THE ACCURACY OR COMPLETENESS OF THE CONTENTS OF THIS PUBLICATION AND RESERVES THE RIGHT TO MAKE CHANGES TO SPECIFICATIONS AND PRODUCT DESCRIPTIONS AT ANY TIME WITHOUT NOTICE. NO LICENSE, WHETHER EXPRESS, IMPLIED, ARISING BY ESTOPPEL OR OTHERWISE, TO ANY INTELLECTUAL PROPERTY RIGHTS IS GRANTED BY THIS DOCUMENT.

TESTING AND OTHER QUALITY CONTROLS ARE USED TO THE EXTENT NATIONAL DEEMS NECESSARY TO SUPPORT NATIONAL'S PRODUCT WARRANTY. EXCEPT WHERE MANDATED BY GOVERNMENT REQUIREMENTS, TESTING OF ALL PARAMETERS OF EACH PRODUCT IS NOT NECESSARILY PERFORMED. NATIONAL ASSUMES NO LIABILITY FOR APPLICATIONS ASSISTANCE OR BUYER PRODUCT DESIGN. BUYERS ARE RESPONSIBLE FOR THEIR PRODUCTS AND APPLICATIONS USING NATIONAL COMPONENTS. PRIOR TO USING OR DISTRIBUTING ANY PRODUCTS THAT INCLUDE NATIONAL COMPONENTS, BUYERS SHOULD PROVIDE ADEQUATE DESIGN, TESTING AND OPERATING SAFEGUARDS.

EXCEPT AS PROVIDED IN NATIONAL'S TERMS AND CONDITIONS OF SALE FOR SUCH PRODUCTS, NATIONAL ASSUMES NO LIABILITY WHATSOEVER, AND NATIONAL DISCLAIMS ANY EXPRESS OR IMPLIED WARRANTY RELATING TO THE SALE AND/OR USE OF NATIONAL PRODUCTS INCLUDING LIABILITY OR WARRANTIES RELATING TO FITNESS FOR A PARTICULAR PURPOSE, MERCHANTABILITY, OR INFRINGEMENT OF ANY PATENT, COPYRIGHT OR OTHER INTELLECTUAL PROPERTY RIGHT.

### LIFE SUPPORT POLICY

**NATIONAL'S PRODUCTS ARE NOT AUTHORIZED FOR USE AS CRITICAL COMPONENTS IN LIFE SUPPORT DEVICES OR SYSTEMS WITHOUT THE EXPRESS PRIOR WRITTEN APPROVAL OF THE CHIEF EXECUTIVE OFFICER AND GENERAL COUNSEL OF NATIONAL SEMICONDUCTOR CORPORATION.** As used herein:

Life support devices or systems are devices which (a) are intended for surgical implant into the body, or (b) support or sustain life and whose failure to perform when properly used in accordance with instructions for use provided in the labeling can be reasonably expected to result in a significant injury to the user. A critical component is any component in a life support device or system whose failure to perform can be reasonably expected to cause the failure of the life support device or system or to affect its safety or effectiveness.

National Semiconductor and the National Semiconductor logo are registered trademarks of National Semiconductor Corporation. All other brand or product names may be trademarks or registered trademarks of their respective holders.

Copyright© 2008 National Semiconductor Corporation

For the most current product information visit us at [www.national.com](http://www.national.com)



**National Semiconductor Americas Technical Support Center**  
Email: [support@nsc.com](mailto:support@nsc.com)  
Tel: 1-800-272-9959

**National Semiconductor Europe Technical Support Center**  
Email: [europe.support@nsc.com](mailto:europe.support@nsc.com)  
German Tel: +49 (0) 180 5010 771  
English Tel: +44 (0) 870 850 4288

**National Semiconductor Asia Pacific Technical Support Center**  
Email: [ap.support@nsc.com](mailto:ap.support@nsc.com)

**National Semiconductor Japan Technical Support Center**  
Email: [jpn.feedback@nsc.com](mailto:jpn.feedback@nsc.com)