

54F/74F258A Quad 2-Input Multiplexer with TRI-STATE® Outputs

General Description

The 'F258A is a quad 2-input multiplexer with TRI-STATE outputs. Four bits of data from two sources can be selected using a common data select input. The four outputs present the selected data in the complement (inverted) form. The outputs may be switched to a high impedance state with a HIGH on the common Output Enable (\overline{OE}) input, allowing the outputs to interface directly with bus-oriented systems.

Features

- Multiplexer expansion by tying outputs together
- Inverting TRI-STATE outputs
- Guaranteed 4000V minimum ESD protection

Ordering Code: See Section 11

Commercial	Military	Package Number	Package Description
74F258APC		N16E	16-Lead (0.300" Wide) Molded Dual-In-Line
	54F258ADM (Note 2)	J16A	16-Lead Ceramic Dual-In-Line
74F258ASC (Note 1)		M16A	16-Lead (0.150" Wide) Molded Small Outline, JEDEC
74F258ASJ (Note 1)		M16D	16-Lead (0.300" Wide) Molded Small Outline, EIAJ
	54F258AFM (Note 2)	W16A	16-Lead Cerpack
	54F258ALL (Note 2)	E20A	20-Lead Ceramic Leadless Chip Carrier, Type C

Note 1: Devices also available in 13" reel. Use suffix = SCX and SJX.

Note 2: Military grade device with environmental and burn-in processing. Use suffix = DMOB, FMOB and LMOB.

Logic Symbols

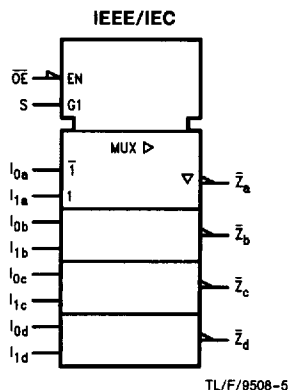
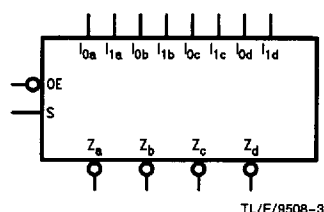

Connection Diagrams

Pin Assignment for DIP, SOIC and Flatpak

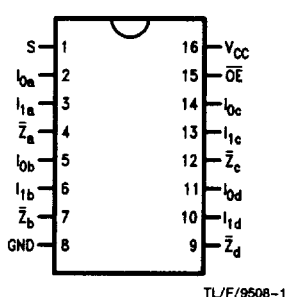

Pin Assignment for LCC

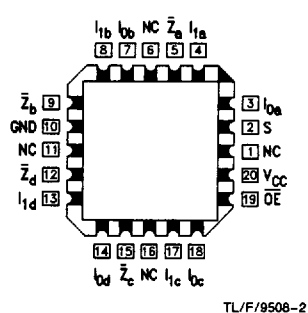

Unit Loading/Fan Out: See Section 2 for U.L. Definitions

Pin Names	Description	54F/74F	
		U.L. HIGH/LOW	Input I_{IH}/I_{IL} Output I_{OH}/I_{OL}
S	Common Data Select Input	1.0/1.0	20 μ A/ -0.6 mA
\overline{OE}	TRI-STATE Output Enable Input (Active LOW)	1.0/1.0	20 μ A/ -0.6 mA
$I_{0a}-I_{0d}$	Data Inputs from Source 0	1.0/1.0	20 μ A/ -0.6 mA
$I_{1a}-I_{1d}$	Data Inputs from Source 1	1.0/1.0	20 μ A/ -0.6 mA
$Z_a-\overline{Z}_d$	TRI-STATE Inverting Data Outputs	150/40 (33.3)	-3 mA/24 mA (20 mA)

Functional Description

The 'F258A is a quad 2-input multiplexer with TRI-STATE outputs. It selects four bits of data from two sources under control of a common Select input (S). When the Select input is LOW, the I_{0x} inputs are selected and when Select is HIGH, the I_{1x} inputs are selected. The data on the selected inputs appears at the outputs in inverted form. The 'F258A is the logic implementation of a 4-pole, 2-position switch where the position of the switch is determined by the logic levels supplied to the Select input. The logic equation for the outputs is shown below:

$$\overline{Z}_n = \overline{OE} \cdot (I_{1n} \cdot S + I_{0n} \cdot \overline{S})$$

When the Output Enable input (\overline{OE}) is HIGH, the outputs are forced to a high impedance OFF state. If the outputs of the TRI-STATE devices are tied together, all but one device must be in the high impedance state to avoid high currents that would exceed the maximum ratings. Designers should ensure that Output Enable signals to TRI-STATE devices whose outputs are tied together are designed so there is no overlap.

Truth Table

Output Enable	Select Input	Data Inputs		Output
\overline{OE}	S	I_0	I_1	\overline{Z}
H	X	X	X	Z
L	H	X	L	H
L	H	X	H	L
L	L	L	X	H
L	L	L	X	L

H = HIGH Voltage Level
L = LOW Voltage Level
X = Immaterial
Z = High Impedance

Logic Diagram

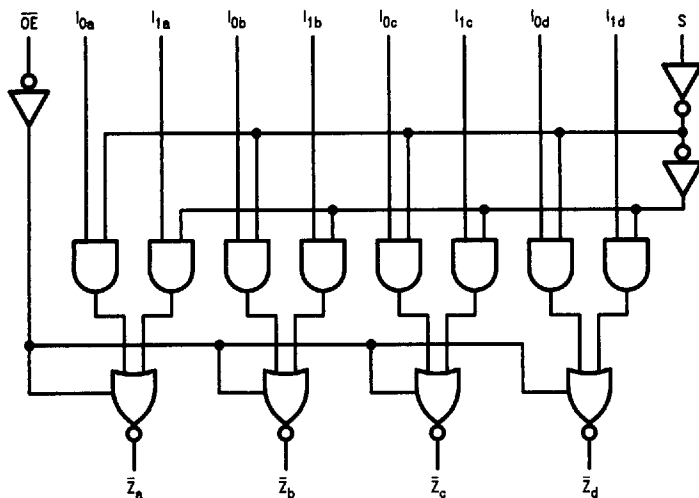

TL/F/9508-4

Please note that this diagram is provided only for the understanding of logic operations and should not be used to estimate propagation delays.

Absolute Maximum Ratings (Note 1)

If Military/Aerospace specified devices are required, please contact the National Semiconductor Sales Office/Distributors for availability and specifications.

Storage Temperature	-65°C to +150°C
Ambient Temperature under Bias	-55°C to +125°C
Junction Temperature under Bias	-55°C to +175°C
Plastic	-55°C to +150°C

V_{CC} Pin Potential to Ground Pin -0.5V to +7.0V

Input Voltage (Note 2) -0.5V to +7.0V

Input Current (Note 2) -30 mA to +5.0 mA

Voltage Applied to Output
in HIGH State (with V_{CC} = 0V)
Standard Output -0.5V to V_{CC}
TRI-STATE Output -0.5V to +5.5V

Current Applied to Output
in LOW State (Max) twice the rated I_{OL} (mA)

ESD Last Passing Voltage (Min) 4000V

Note 1: Absolute maximum ratings are values beyond which the device may be damaged or have its useful life impaired. Functional operation under these conditions is not implied.

Note 2: Either voltage limit or current limit is sufficient to protect inputs.

Recommended Operating Conditions

Free Air Ambient Temperature	-55°C to +125°C
Military	0°C to +70°C
Commercial	
Supply Voltage	+4.5V to +5.5V
Military	+4.5V to +5.5V
Commercial	

DC Electrical Characteristics

Symbol	Parameter	54F/74F			Units	V _{CC}	Conditions
		Min	Typ	Max			
V _{IH}	Input HIGH Voltage	2.0			V		Recognized as a HIGH Signal
V _{IL}	Input LOW Voltage			0.8	V		Recognized as a LOW Signal
V _{CD}	Input Clamp Diode Voltage			-1.2	V	Min	I _{IN} = -18 mA
V _{OH}	Output HIGH Voltage	54F 10% V _{CC} 54F 10% V _{CC} 74F 10% V _{CC} 74F 10% V _{CC} 74F 5% V _{CC} 74F 5% V _{CC}	2.5 2.4 2.5 2.4 2.7 2.7		V	Min	I _{OH} = -1 mA I _{OH} = -3 mA I _{OH} = -1 mA I _{OH} = -3 mA I _{OH} = -1 mA I _{OH} = -3 mA
V _{OL}	Output LOW Voltage	54F 10% V _{CC} 74F 10% V _{CC}		0.5 0.5	V	Min	I _{OL} = 20 mA I _{OL} = 24 mA
I _{IH}	Input HIGH Current	54F 74F		20.0 5.0	μA	Max	V _{IN} = 2.7V
I _{BVI}	Input HIGH Current Breakdown Test	54F 74F		100 7.0	μA	Max	V _{IN} = 7.0V
I _{CEX}	Output HIGH Leakage Current	54F 74F		250 50	μA	Max	V _{OUT} = V _{CC}
V _{ID}	Input Leakage Test	74F	4.75		V	0.0	I _{ID} = 1.9 μA All Other Pins Grounded
I _{OD}	Output Leakage Circuit Current	74F		3.75	μA	0.0	V _{IOD} = 150 mV All Other Pins Grounded
I _{IL}	Input LOW Current			-0.6	mA	Max	V _{IN} = 0.5V
I _{OZH}	Output Leakage Current			50	μA	Max	V _{OUT} = 2.7V
I _{OZL}	Output Leakage Current			-50	μA	Max	V _{OUT} = 0.5V
I _{OS}	Output Short-Circuit Current			-60	mA	Max	V _{OUT} = 0V
I _{ZZ}	Bus Drainage Test			500	μA	0.0V	V _{OUT} = V _{CC}
I _{CCH}	Power Supply Current		6.2	9.5	mA	Max	V _O = HIGH
I _{CCL}	Power Supply Current		15.1	23	mA	Max	V _O = LOW
I _{CCZ}	Power Supply Current		11.3	17	mA	Max	V _O = HIGH Z

AC Electrical Characteristics: See Section 2 for Waveforms and Load Configurations

Symbol	Parameter	74F			54F		74F		Units	Fig. No.
		T _A = +25°C V _{CC} = +5.0V C _L = 50 pF			T _A , V _{CC} = Mil C _L = 50 pF		T _A , V _{CC} = Com C _L = 50 pF			
		Min	Typ	Max	Min	Max	Min	Max		
t _{PLH}	Propagation Delay I _n to Z _n	2.5		5.3	2.0	7.5	2.0	6.0	ns	2-3
t _{PHL}		1.0		4.0	1.0	6.0	1.0	5.0		
t _{PLH}	Propagation Delay S to Z _n	3.0		7.5	3.0	9.5	3.0	8.5	ns	2-3
t _{PHL}		2.5		7.0	2.5	9.0	2.5	8.0		
t _{PZH}	Output Enable Time	2.0		6.0	2.0	8.0	2.0	7.0	ns	2-5
t _{PZL}		2.5		7.0	2.5	9.0	2.5	8.0		
t _{PHZ}	Output Disable Time	2.0		6.0	1.5	7.0	2.0	7.0	ns	2-5
t _{PLZ}		2.0		6.0	2.0	8.5	2.0	7.0		