

MACH220-10/12/15/20

Lattice/Vantis

High-Density EE CMOS Programmable Logic

DISTINCTIVE CHARACTERISTICS

- 68 Pins
 - 96 Macrocells
 - 10 ns t_{PD}
 - 100 MHz f_{CNT}
 - 56 Inputs with pull-up resistors
 - 48 Outputs
 - 96 Flip-flops; 4 clock choices
 - 8 "PAL26V12" blocks with buried macrocells
 - Pin-compatible with MACH120 and MACH221
-

GENERAL DESCRIPTION

The MACH220 is a member of the high-performance EE CMOS MACH 2 device family. This device has approximately nine times the logic macrocell capability of the popular PAL22V10 without loss of speed.

The MACH220 consists of eight PAL blocks interconnected by a programmable switch matrix. The eight PAL blocks are essentially "PAL26V12" structures complete with product-term arrays, and programmable macrocells, including buried macrocells. The switch matrix connects the PAL blocks to each other and to all input pins, providing a high degree of connectivity between the fully-connected PAL blocks. This allows designs to be placed and routed efficiently.

The MACH220 has two kinds of macrocell: output and buried. The output macrocell provides registered, latched, or combinatorial outputs with programmable

polarity. If a registered configuration is chosen, the register can be configured as D-type or T-type to help reduce the number of product terms. The register type decision can be made by the designer or by the software. All output macrocells can be connected to an I/O cell. If a buried macrocell is desired, the internal feedback path from the macrocell can be used, which frees up the I/O pin for use as an input.

The MACH220 has dedicated buried macrocells which, in addition to the capabilities of the output macrocell, also provide input registers for use in synchronizing signals and reducing setup time requirements.

BLOCK DIAGRAM

*If you would like to view
Block Diagram in full size,
please click on the box.*

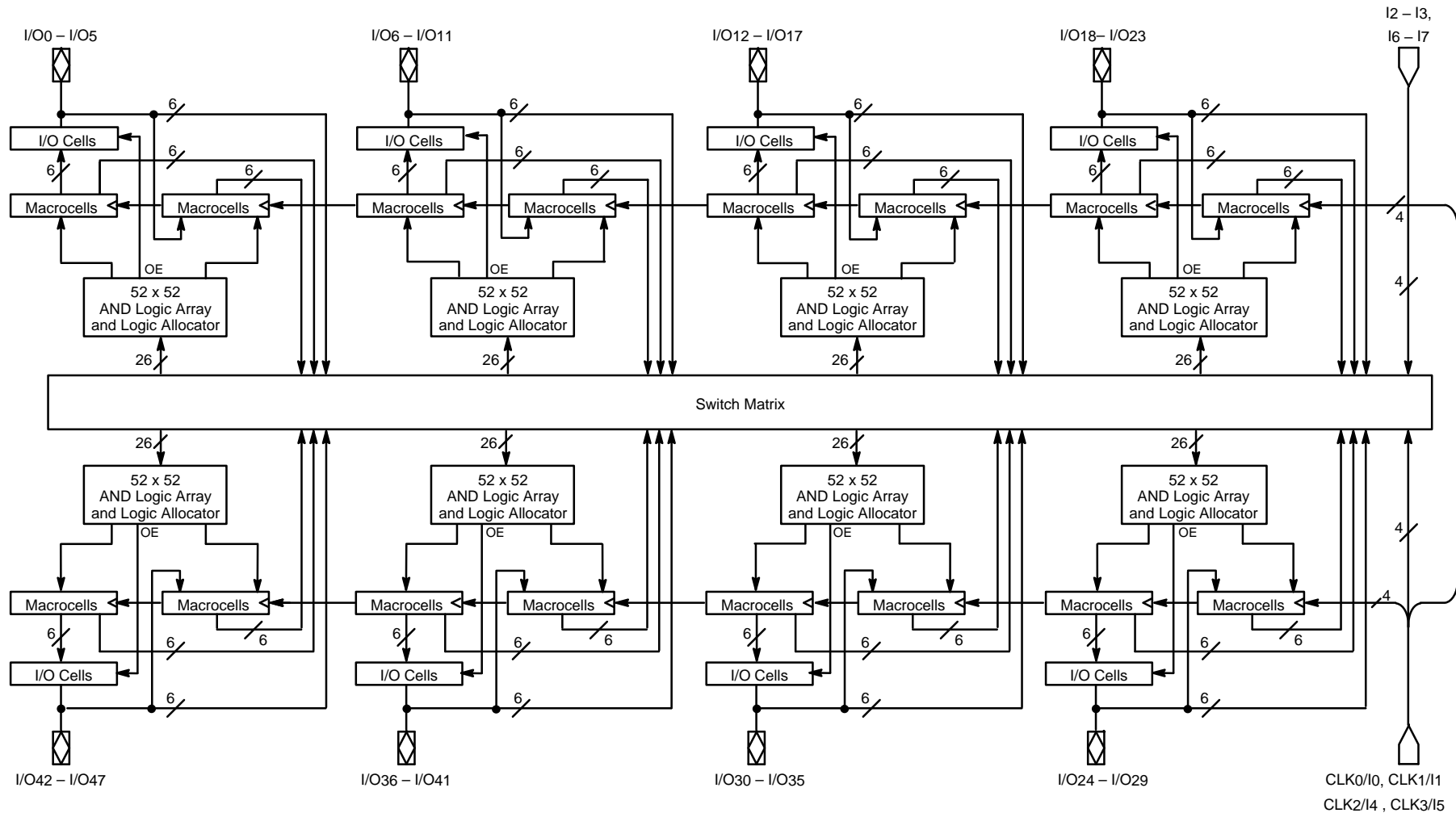

CONNECTION DIAGRAMS

Top View

PLCC

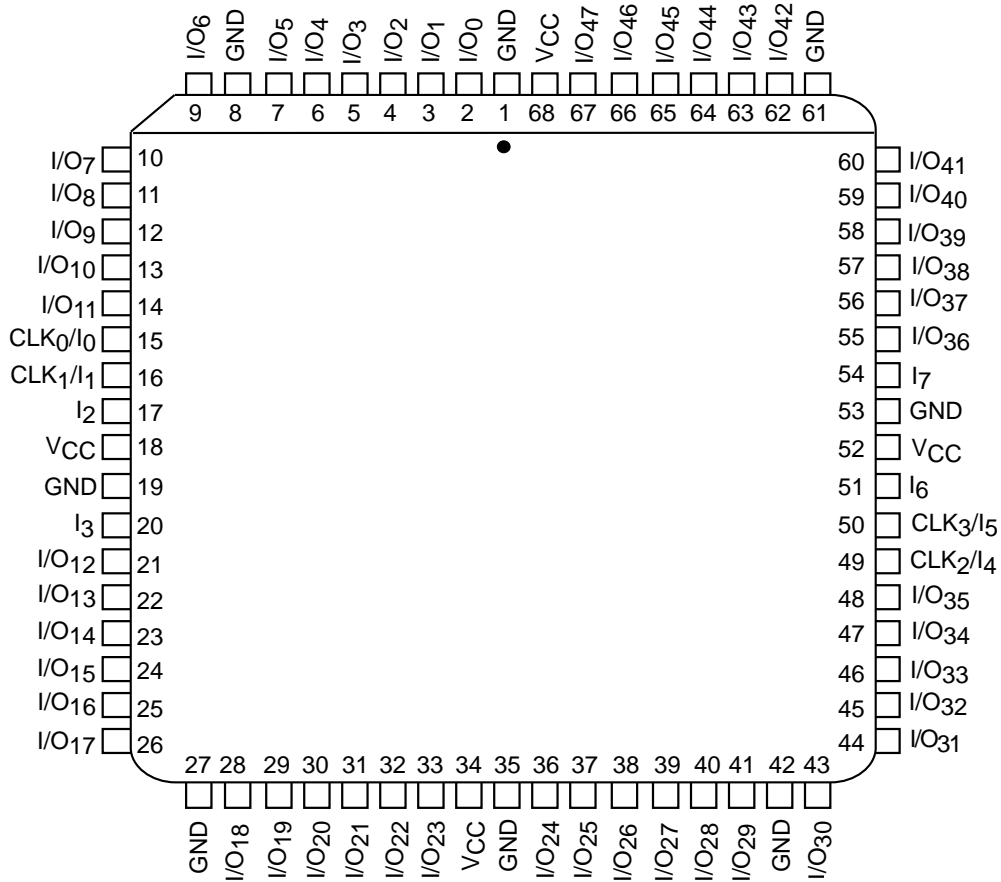

14130I-2

Note:
Pin-compatible with MACH120 and MACH221.

PIN DESIGNATIONS

- CLK/I = Clock or Input
- GND = Ground
- I = Input
- I/O = Input/Output
- Vcc = Supply Voltage

ORDERING INFORMATION

Commercial Products

Programmable logic products for commercial applications are available with several ordering options. The order number (Valid Combination) is formed by a combination of:

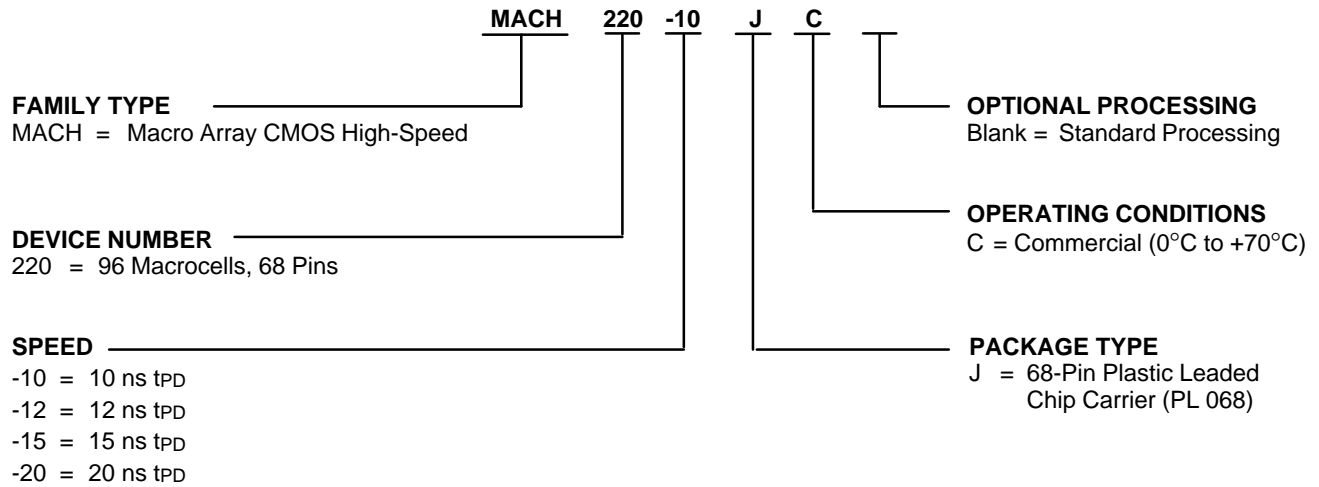

Valid Combinations	
MACH220-10	JC
MACH220-12	
MACH220-15	
MACH220-20	

Valid Combinations

The Valid Combinations table lists configurations planned to be supported in volume for this device. Consult your local sales office to confirm availability of specific valid combinations and to check on newly released combinations.

ORDERING INFORMATION

Industrial Products

Programmable logic products for industrial applications are available with several ordering options. The order number (Valid Combination) is formed by a combination of:

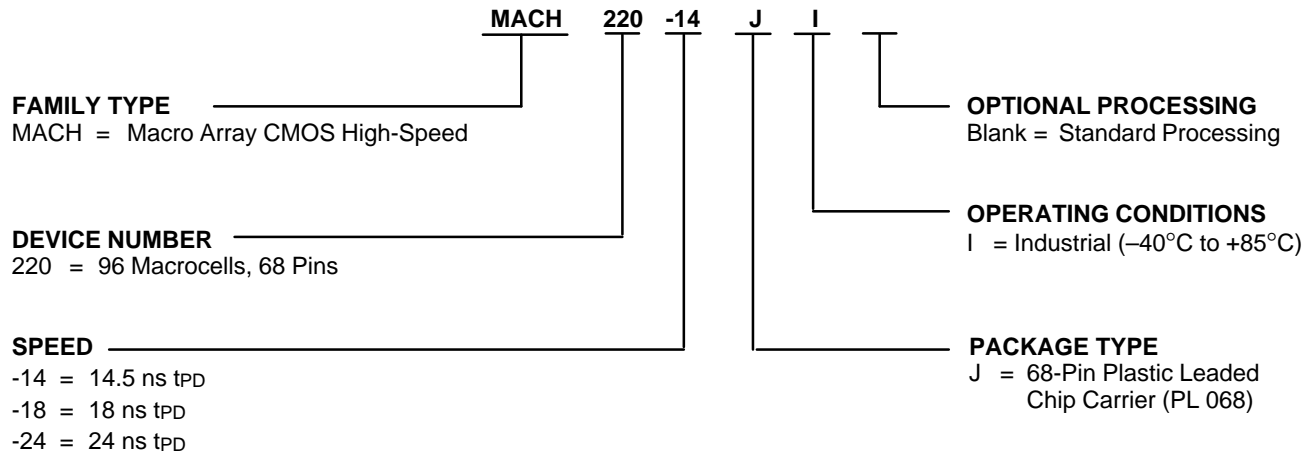

Valid Combinations	
MACH220-14	JI
MACH220-18	
MACH220-24	

Valid Combinations

The Valid Combinations table lists configurations planned to be supported in volume for this device. Consult your local sales office to confirm availability of specific valid combinations and to check on newly released combinations.

FUNCTIONAL DESCRIPTION

The MACH220 consists of eight PAL blocks connected by a switch matrix. There are 48 I/O pins and 4 dedicated input pins feeding the switch matrix. These signals are distributed to the four PAL blocks for efficient design implementation. There are 4 clock pins that can also be used as dedicated inputs.

All inputs and I/O pins have built-in pull-up resistors. While it is always good design practice to tie unused pins high or low, the pull-up resistors provide design security and stability in the event that unused pins are left disconnected.

The PAL Blocks

Each PAL block in the MACH220 (Figure 1) contains a 48-product-term logic array, a logic allocator, 6 output macrocells, 6 buried macrocells, and 6 I/O cells. The switch matrix feeds each PAL block with 26 inputs. This makes the PAL block look effectively like an independent “PAL26V12” with 6 buried macrocells.

In addition to the logic product terms, two output enable product terms, an asynchronous reset product term, and an asynchronous preset product term are provided. One of the two output enable product terms can be chosen within each I/O cell in the PAL block. All flip-flops within the PAL block are initialized together.

The Switch Matrix

The MACH220 switch matrix is fed by the inputs and feedback signals from the PAL blocks. Each PAL block provides 12 internal feedback signals and 6 I/O feedback signals. The switch matrix distributes these signals back to the PAL blocks in an efficient manner that also provides for high performance. The design software automatically configures the switch matrix when fitting a design into the device.

The Product-Term Array

The MACH220 product-term array consists of 48 product terms for logic use, and 4 special-purpose product terms. Two of the special-purpose product terms provide programmable output enable, one provides asynchronous reset, and one provides asynchronous preset.

The Logic Allocator

The logic allocator in the MACH220 takes the 48 logic product terms and allocates them to the 12 macrocells as needed. Each macrocell can be driven by up to 16 product terms. The design software automatically configures the logic allocator when fitting the design into the device.

Table 1 illustrates which product term clusters are available to each macrocell within a PAL block. Refer to Figure 1 for cluster and macrocell numbers.

Table 1. Logic Allocation

Macrocell		Available Clusters
Output	Buried	
M ₀	M ₁	C ₀ , C ₁ , C ₂ C ₀ , C ₁ , C ₂ , C ₃
M ₂	M ₃	C ₁ , C ₂ , C ₃ , C ₄ C ₂ , C ₃ , C ₄ , C ₅
M ₄	M ₅	C ₃ , C ₄ , C ₅ , C ₆ C ₄ , C ₅ , C ₆ , C ₇
M ₆	M ₇	C ₅ , C ₆ , C ₇ , C ₈ C ₆ , C ₇ , C ₈ , C ₉
M ₈	M ₉	C ₇ , C ₈ , C ₉ , C ₁₀ C ₈ , C ₉ , C ₁₀ , C ₁₁
M ₁₀	M ₁₁	C ₉ , C ₁₀ , C ₁₁ C ₁₀ , C ₁₁

The Macrocell

The MACH220 has two types of macrocell: output and buried. The output macrocells can be configured as either registered, latched, or combinatorial, with programmable polarity. The macrocell provides internal feedback whether configured with or without the flip-flop. The registers can be configured as D-type or T-type, allowing for product-term optimization.

The flip-flops can individually select one of four clock/gate pins, which are also available as data inputs. The registers are clocked on the LOW-to-HIGH transition of the clock signal. The latch holds its data when the gate input is HIGH, and is transparent when the gate input is LOW. The flip-flops can also be asynchronously initialized with the common asynchronous reset and preset product terms.

The buried macrocells are the same as the output macrocells if they are used for generating logic. In that case, the only thing that distinguishes them from the output macrocells is the fact that there is no I/O cell connection, and the signal is only used internally. The buried macrocell can also be configured as an input register or latch.

The I/O Cell

The I/O cell in the MACH220 consists of a three-state output buffer. The three-state buffer can be configured in one of three ways: always enabled, always disabled, or controlled by a product term. If product term control is chosen, one of two product terms may be used to provide the control. The two product terms that are available are common to all I/O cells in a PAL block.

These choices make it possible to use the macrocell as an output, an input, a bidirectional pin, or a three-state output for use in driving a bus.

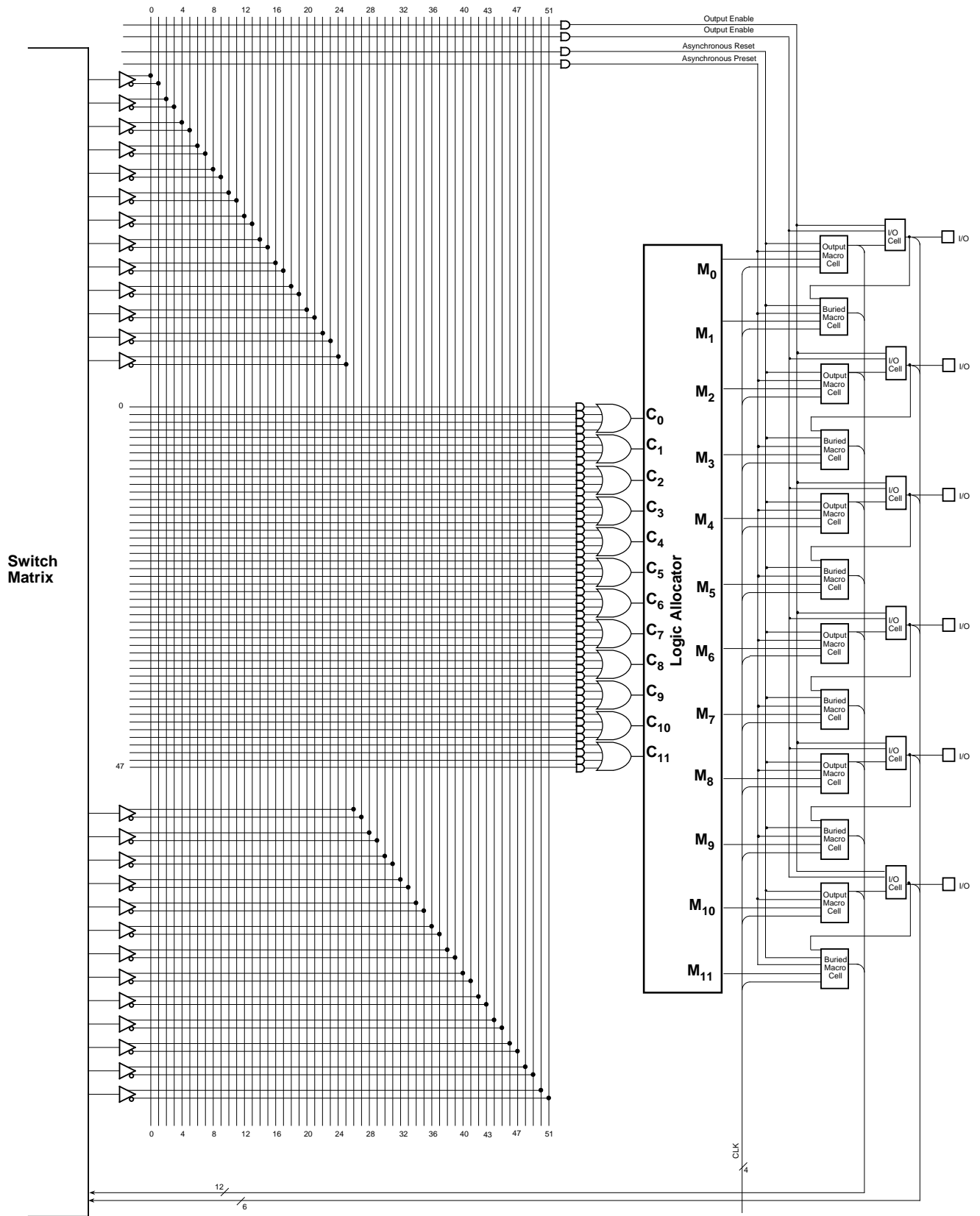

141301-3

Figure 1. MACH220 PAL Block

ABSOLUTE MAXIMUM RATINGS

Storage Temperature	−65°C to +150°C
Ambient Temperature with Power Applied	−55°C to +125°C
Supply Voltage with Respect to Ground	−0.5 V to +7.0 V
DC Input Voltage	−0.5 V to $V_{CC} + 0.5$ V
DC Output or I/O Pin Voltage	−0.5 V to $V_{CC} + 0.5$ V
Static Discharge Voltage	2001 V
Latchup Current ($T_A = 0^\circ\text{C}$ to $+70^\circ\text{C}$)	200 mA

Stresses above those listed under Absolute Maximum Ratings may cause permanent device failure. Functionality at or above these limits is not implied. Exposure to Absolute Maximum Ratings for extended periods may affect device reliability. Programming conditions may differ.

OPERATING RANGES

Commercial (C) Devices

Temperature (T_A) Operating in Free Air	0°C to +70°C
Supply Voltage (V_{CC}) with Respect to Ground	+4.75 V to +5.25 V

Operating ranges define those limits between which the functionality of the device is guaranteed.

DC CHARACTERISTICS over COMMERCIAL operating ranges unless otherwise specified

Parameter Symbol	Parameter Description	Test Conditions	Min	Typ	Max	Unit
V_{OH}	Output HIGH Voltage	$I_{OH} = -3.2$ mA, $V_{CC} = \text{Min}$ $V_{IN} = V_{IH}$ or V_{IL}	2.4			V
V_{OL}	Output LOW Voltage	$I_{OL} = 16$ mA, $V_{CC} = \text{Min}$ $V_{IN} = V_{IH}$ or V_{IL}			0.5	V
V_{IH}	Input HIGH Voltage	Guaranteed Input Logical HIGH Voltage for all Inputs (Note 1)	2.0			V
V_{IL}	Input LOW Voltage	Guaranteed Input Logical LOW Voltage for all Inputs (Note 1)			0.8	V
I_{IH}	Input HIGH Leakage Current	$V_{IN} = 5.25$ V, $V_{CC} = \text{Max}$ (Note 2)			10	μA
I_{IL}	Input LOW Leakage Current	$V_{IN} = 0$ V, $V_{CC} = \text{Max}$ (Note 2)			−100	μA
I_{OZH}	Off-State Output Leakage Current HIGH	$V_{OUT} = 5.25$ V, $V_{CC} = \text{Max}$ $V_{IN} = V_{IH}$ or V_{IL} (Note 2)			10	μA
I_{OZL}	Off-State Output Leakage Current LOW	$V_{OUT} = 0$ V, $V_{CC} = \text{Max}$ $V_{IN} = V_{IH}$ or V_{IL} (Note 2)			−100	μA
I_{SC}	Output Short-Circuit Current	$V_{OUT} = 0.5$ V, $V_{CC} = \text{Max}$ (Note 3)		−30	−130	mA
I_{CC}	Supply Current (Typical)	$V_{CC} = 5$ V, $T_A = 25^\circ\text{C}$, $f = 25$ MHz (Note 4)		205		mA

Notes:

- These are absolute values with respect to device ground and all overshoots due to system or tester noise are included.
- I/O pin leakage is the worst case of I_{IL} and I_{OZL} (or I_{IH} and I_{OZH}).
- Not more than one output should be shorted at a time and duration of the short-circuit should not exceed one second. $V_{OUT} = 0.5$ V has been chosen to avoid test problems caused by tester ground degradation.
- Measured with a 12-bit up/down counter pattern. This pattern is programmed in each PAL block and is capable of being loaded, enabled, and reset.

CAPACITANCE (Note 1)

Parameter Symbol	Parameter Description	Test Conditions		Typ	Unit
C _{IN}	Input Capacitance	V _{IN} = 2.0 V	V _{CC} = 5.0 V, T _A = 25°C, f = 1 MHz	6	pF
C _{OUT}	Output Capacitance	V _{OUT} = 2.0 V		8	pF

SWITCHING CHARACTERISTICS over COMMERCIAL operating ranges (Note 2)

Parameter Symbol	Parameter Description		-10		Unit
			Min	Max	
t _{PD}	Input, I/O, or Feedback to Combinatorial Output			10	ns
t _S	Setup Time from Input, I/O, or Feedback to Clock		D-type	6.5	ns
			T-type	7.5	ns
t _H	Register Data Hold Time		0		ns
t _{CO}	Clock to Output			6.0	ns
t _{WL}	Clock Width	LOW	4		ns
t _{WH}		HIGH	4		ns
f _{MAX}	Maximum Frequency (Note 1)	External Feedback	D-type	80	MHz
			T-type	74	MHz
		Internal Feedback (f _{CNT})	D-type	100	MHz
			T-type	91	MHz
No Feedback			125	MHz	
t _{SL}	Setup Time from Input, I/O, or Feedback to Gate		7		ns
t _{HL}	Latch Data Hold Time		0		ns
t _{GO}	Gate to Output			7.5	ns
t _{GWL}	Gate Width LOW		4		ns
t _{PDL}	Input, I/O, or Feedback to Output Through Transparent Input or Output Latch			14	ns
t _{SIR}	Input Register Setup Time		2		ns
t _{HIR}	Input Register Hold Time		2		ns
t _{ICO}	Input Register Clock to Combinatorial Output			15	ns
t _{ICS}	Input Register Clock to Output Register Setup		D-type	11	ns
			T-type	12	ns
t _{WCL}	Input Register Clock Width	LOW	4	ns	
t _{WCH}		HIGH	4	ns	
f _{MAXIR}	Maximum Input Register Frequency		125		MHz
t _{SIL}	Input Latch Setup Time		2		ns
t _{HIL}	Input Latch Hold Time		2		ns
t _{IGO}	Input Latch Gate to Combinatorial Output			17	ns
t _{IGOL}	Input Latch Gate to Output Through Transparent Output Latch			18	ns
t _{SLL}	Setup Time from Input, I/O, or Feedback Through Transparent Input Latch to Output Latch Gate		10		ns
t _{IGS}	Input Latch Gate to Output Latch Setup		11		ns

**SWITCHING CHARACTERISTICS over COMMERCIAL operating ranges (Note 2)
(continued)**

Parameter Symbol	Parameter Description	-10		Unit
		Min	Max	
t _{WGL}	Input Latch Gate Width LOW	4		ns
t _{PDLL}	Input, I/O, or Feedback to Output Through Transparent Input and Output Latches		16	ns
t _{AR}	Asynchronous Reset to Registered or Latched Output		15	ns
t _{ARW}	Asynchronous Reset Width (Note 1)	10		ns
t _{ARR}	Asynchronous Reset Recovery Time (Note 1)	8		ns
t _{AP}	Asynchronous Preset to Registered or Latched Output		15	ns
t _{APW}	Asynchronous Preset Width (Note 1)	10		ns
t _{APR}	Asynchronous Preset Recovery Time (Note 1)	8		ns
t _{EA}	Input, I/O, or Feedback to Output Enable		10	ns
t _{ER}	Input, I/O, or Feedback to Output Disable		10	ns

Notes:

1. These parameters are not 100% tested, but are evaluated at initial characterization and at any time the design is modified where capacitance may be affected.
2. See Switching Test Circuit, for test conditions.

ABSOLUTE MAXIMUM RATINGS

Storage Temperature	65°C to +150°C
Ambient Temperature with Power Applied	-55°C to +125°C
Supply Voltage with Respect to Ground	-0.5 V to +7.0 V
DC Input Voltage	-0.5 V to $V_{CC} + 0.5$ V
DC Output or I/O Pin Voltage	-0.5 V to $V_{CC} + 0.5$ V
Static Discharge Voltage	2001 V
Latchup Current ($T_A = 0^\circ\text{C}$ to $+70^\circ\text{C}$)	200 mA

Stresses above those listed under Absolute Maximum Ratings may cause permanent device failure. Functionality at or above these limits is not implied. Exposure to Absolute Maximum Ratings for extended periods may affect device reliability. Programming conditions may differ.

OPERATING RANGES

Commercial (C) Devices

Temperature (T_A) Operating in Free Air	0°C to +70°C
Supply Voltage (V_{CC}) with Respect to Ground	+4.75 V to +5.25 V

Operating ranges define those limits between which the functionality of the device is guaranteed.

DC CHARACTERISTICS over COMMERCIAL operating ranges unless otherwise specified

Parameter Symbol	Parameter Description	Test Conditions	Min	Typ	Max	Unit
V_{OH}	Output HIGH Voltage	$I_{OH} = -3.2$ mA, $V_{CC} = \text{Min}$ $V_{IN} = V_{IH}$ or V_{IL}	2.4			V
V_{OL}	Output LOW Voltage	$I_{OL} = 16$ mA, $V_{CC} = \text{Min}$ $V_{IN} = V_{IH}$ or V_{IL}			0.5	V
V_{IH}	Input HIGH Voltage	Guaranteed Input Logical HIGH Voltage for all Inputs (Note 1)	2.0			V
V_{IL}	Input LOW Voltage	Guaranteed Input Logical LOW Voltage for all Inputs (Note 1)			0.8	V
I_{IH}	Input HIGH Leakage Current	$V_{IN} = 5.25$ V, $V_{CC} = \text{Max}$ (Note 2)			10	μA
I_{IL}	Input LOW Leakage Current	$V_{IN} = 0$ V, $V_{CC} = \text{Max}$ (Note 2)			-100	μA
I_{OZH}	Off-State Output Leakage Current HIGH	$V_{OUT} = 5.25$ V, $V_{CC} = \text{Max}$ $V_{IN} = V_{IH}$ or V_{IL} (Note 2)			10	μA
I_{OZL}	Off-State Output Leakage Current LOW	$V_{OUT} = 0$ V, $V_{CC} = \text{Max}$ $V_{IN} = V_{IH}$ or V_{IL} (Note 2)			-100	μA
I_{SC}	Output Short-Circuit Current	$V_{OUT} = 0.5$ V, $V_{CC} = \text{Max}$ (Note 3)		-30	-130	mA
I_{CC}	Supply Current (Typical)	$V_{CC} = 5$ V, $T_A = 25^\circ\text{C}$, $f = 25$ MHz (Note 4)		205		mA

Notes:

- These are absolute values with respect to device ground and all overshoots due to system or tester noise are included.
- I/O pin leakage is the worst case of I_{IL} and I_{OZL} (or I_{IH} and I_{OZH}).
- Not more than one output should be shorted at a time and duration of the short-circuit should not exceed one second.
 $V_{OUT} = 0.5$ V has been chosen to avoid test problems caused by tester ground degradation.
- Measured with a 12-bit up/down counter pattern. This pattern is programmed in each PAL block and is capable of being loaded, enabled, and reset.

CAPACITANCE (Note 1)

Parameter Symbol	Parameter Description	Test Conditions		Typ	Unit
C _{IN}	Input Capacitance	V _{IN} = 2.0 V	V _{CC} = 5.0 V, T _A = 25°C, f = 1 MHz	6	pF
C _{OUT}	Output Capacitance	V _{OUT} = 2.0 V		8	pF

SWITCHING CHARACTERISTICS over COMMERCIAL operating ranges (Note 2)

Parameter Symbol	Parameter Description		-12		-15		-20		Unit	
			Min	Max	Min	Max	Min	Max		
t _{PD}	Input, I/O, or Feedback to Combinatorial Output (Note 3)			12		15		20	ns	
t _S	Setup Time from Input, I/O, or Feedback to Clock		D-type	7		10		13	ns	
			T-type	8		11		14	ns	
t _H	Register Data Hold Time			0		0		0	ns	
t _{CO}	Clock to Output (Note 3)			8		10		12	ns	
t _{WL}	Clock Width		LOW	6		6		8	ns	
t _{WH}			HIGH	6		6		8	ns	
f _{MAX}	Maximum Frequency (Note 1)	External Feedback	1/(t _S + t _{CO})	D-type	66.7		50		40	MHz
			T-type	62.5		47.6		38.5	MHz	
		Internal Feedback (f _{CNT})	D-type	83.3		66.6		50	MHz	
			T-type	76.9		62.5		47.6	MHz	
No Feedback	1/(t _{WL} + t _{WH})	83.3		83.3		62.5	MHz			
t _{SL}	Setup Time from Input, I/O, or Feedback to Gate			7		10		13	ns	
t _{HL}	Latch Data Hold Time			0		0		0	ns	
t _{GO}	Gate to Output (Note 3)				10		11		12	ns
t _{GWL}	Gate Width LOW			6		6		8	ns	
t _{PDL}	Input, I/O, or Feedback to Output Through Transparent Input or Output Latch				14		17		22	ns
t _{SIR}	Input Register Setup Time			2		2		2	ns	
t _{HIR}	Input Register Hold Time			2		2.5		3	ns	
t _{ICO}	Input Register Clock to Combinatorial Output				15		18		23	ns
t _{ICS}	Input Register Clock to Output Register Setup		D-type	12		15		20	ns	
			T-type	13		16		21	ns	
t _{WICL}	Input Register Clock Width		LOW	6		6		8	ns	
t _{WICH}			HIGH	6		6		8	ns	
f _{MAXIR}	Maximum Input Register Frequency	1/(t _{WICL} + t _{WICH})		83.3		83.3		62.5	MHz	
t _{SIL}	Input Latch Setup Time			2		2		2	ns	
t _{HIL}	Input Latch Hold Time			2		2.5		3	ns	
t _{IGO}	Input Latch Gate to Combinatorial Output				17		20		25	ns
t _{IGOL}	Input Latch Gate to Output Through Transparent Output Latch				19		22		27	ns
t _{SLL}	Setup Time from Input, I/O, or Feedback Through Transparent Input Latch to Output Latch Gate			9		12		15	ns	
t _{IGS}	Input Latch Gate to Output Latch Setup			13		16		21	ns	

**SWITCHING CHARACTERISTICS over COMMERCIAL operating ranges (Note 2)
(continued)**

Parameter Symbol	Parameter Description	-12		-15		-20		Unit
		Min	Max	Min	Max	Min	Max	
twIGL	Input Latch Gate Width LOW	6		6		8		ns
tPDLL	Input, I/O, or Feedback to Output Through Transparent Input and Output Latches		16		19		24	ns
tAR	Asynchronous Reset to Registered or Latched Output		16		20		25	ns
tARW	Asynchronous Reset Width (Note 1)	12		15		20		ns
tARR	Asynchronous Reset Recovery Time (Note 1)	8		10		15		ns
tAP	Asynchronous Preset to Registered or Latched Output		16		20		25	ns
tAPW	Asynchronous Preset Width (Note 1)	12		15		20		ns
tAPR	Asynchronous Preset Recovery Time (Note 1)	8		10		15		ns
tEA	Input, I/O, or Feedback to Output Enable (Note 3)		12		15		20	ns
tER	Input, I/O, or Feedback to Output Disable (Note 3)		12		15		20	ns

Notes:

1. *These parameters are not 100% tested, but are evaluated at initial characterization and at any time the design is modified where capacitance may be affected.*
2. *See Switching Test Circuit for test conditions.*
3. *Parameters measured with 24 outputs switching.*

ABSOLUTE MAXIMUM RATINGS

Storage Temperature 65°C to +150°C
 Ambient Temperature
 with Power Applied -55°C to +125°C
 Supply Voltage with
 Respect to Ground -0.5 V to +7.0 V
 DC Input Voltage -0.5 V to $V_{CC} + 0.5$ V
 DC Output or
 I/O Pin Voltage -0.5 V to $V_{CC} + 0.5$ V
 Static Discharge Voltage 2001 V
 Latchup Current
 ($T_A = -40^\circ\text{C}$ to $+85^\circ\text{C}$) 200 mA

Stresses above those listed under Absolute Maximum Ratings may cause permanent device failure. Functionality at or above these limits is not implied. Exposure to Absolute Maximum Ratings for extended periods may affect device reliability. Programming conditions may differ.

INDUSTRIAL OPERATING RANGES

Ambient Temperature (T_A)
 Operating in Free Air -40°C to $+85^\circ\text{C}$
 Supply Voltage (V_{CC}) with
 Respect to Ground +4.5 V to +5.5 V

Operating ranges define those limits between which the functionality of the device is guaranteed.

DC CHARACTERISTICS over INDUSTRIAL operating ranges unless otherwise specified

Parameter Symbol	Parameter Description	Test Conditions	Min	Typ	Max	Unit
V_{OH}	Output HIGH Voltage	$I_{OH} = -3.2$ mA, $V_{CC} = \text{Min}$ $V_{IN} = V_{IH}$ or V_{IL}	2.4			V
V_{OL}	Output LOW Voltage	$I_{OL} = 16$ mA, $V_{CC} = \text{Min}$ $V_{IN} = V_{IH}$ or V_{IL}			0.5	V
V_{IH}	Input HIGH Voltage	Guaranteed Input Logical HIGH Voltage for all Inputs (Note 1)	2.0			V
V_{IL}	Input LOW Voltage	Guaranteed Input Logical LOW Voltage for all Inputs (Note 1)			0.8	V
I_{IH}	Input HIGH Leakage Current	$V_{IN} = 5.25$ V, $V_{CC} = \text{Max}$ (Note 2)			10	μA
I_{IL}	Input LOW Leakage Current	$V_{IN} = 0$ V, $V_{CC} = \text{Max}$ (Note 2)			-100	μA
I_{OZH}	Off-State Output Leakage Current HIGH	$V_{OUT} = 5.25$ V, $V_{CC} = \text{Max}$ $V_{IN} = V_{IH}$ or V_{IL} (Note 2)			10	μA
I_{OZL}	Off-State Output Leakage Current LOW	$V_{OUT} = 0$ V, $V_{CC} = \text{Max}$ $V_{IN} = V_{IH}$ or V_{IL} (Note 2)			-100	μA
I_{SC}	Output Short-Circuit Current	$V_{OUT} = 0.5$ V, $V_{CC} = \text{Max}$ (Note 3)	-30		-130	mA
I_{CC}	Supply Current (Typical)	$V_{CC} = 5$ V, $T_A = 25^\circ\text{C}$, $f = 25$ MHz (Note 4)		205		mA

Notes:

1. These are absolute values with respect to device ground and all overshoots due to system and/or tester noise are included.
2. I/O pin leakage is the worst case of I_{IL} and I_{OZL} (or I_{IH} and I_{OZH}).
3. Not more than one output should be shorted at a time. Duration of the short-circuit should not exceed one second. $V_{OUT} = 0.5$ V has been chosen to avoid test problems caused by tester ground degradation.
4. Measured with a 12-bit up/down counter pattern. This pattern is programmed in each PAL block and is capable of being loaded, enabled, and reset.

CAPACITANCE (Note 1)

Parameter Symbol	Parameter Description	Test Conditions		Typ	Unit
C _{IN}	Input Capacitance	V _{IN} = 2.0 V	V _{CC} = 5.0 V, T _A = 25°C, f = 1 MHz	6	pF
C _{OUT}	Output Capacitance	V _{OUT} = 2.0 V		8	pF

SWITCHING CHARACTERISTICS over INDUSTRIAL operating ranges (Note 2)

Parameter Symbol	Parameter Description		-14		-18		-24		Unit	
			Min	Max	Min	Max	Min	Max		
t _{PD}	Input, I/O, or Feedback to Combinatorial Output (Note 3)			14.5		18		24	ns	
t _s	Setup Time from Input, I/O, or Feedback to Clock		D-type	8.5		12		16	ns	
			T-type	10		13.5		17	ns	
t _H	Register Data Hold Time			0		0		0	ns	
t _{CO}	Clock to Output (Note 3)			10		12		14.5	ns	
t _{WL}	Clock Width		LOW	7.5		7.5		10	ns	
t _{WH}			HIGH	7.5		7.5		10	ns	
f _{MAX}	Maximum Frequency (Note 1)	External Feedback	1/(t _s + t _{CO})	D-type	53		40		32	MHz
			T-type	50		38		30.5	MHz	
		Internal Feedback (f _{CNT})		D-type	61.5		53		38	MHz
				T-type	57		44		34.5	MHz
No Feedback		1/(t _{WL} + t _{WH})		66.5		66.5		50	MHz	
t _{SL}	Setup Time from Input, I/O, or Feedback to Gate			8.5		12		16	ns	
t _{HL}	Latch Data Hold Time			0		0		0	ns	
t _{GO}	Gate to Output (Note 3)			12		13.5		14.5	ns	
t _{GWL}	Gate Width LOW			7.5		7.5		10	ns	
t _{PDL}	Input, I/O, or Feedback to Output Through Transparent Input or Output Latch			17		20.5		26.5	ns	
t _{SIR}	Input Register Setup Time			2.5		2.5		2.5	ns	
t _{HIR}	Input Register Hold Time			3		3.5		4	ns	
t _{ICO}	Input Register Clock to Combinatorial Output			18		22		28	ns	
t _{ICS}	Input Register Clock to Output Register Setup		D-type	14.5		18		24	ns	
			T-type	16		19.5		25.5	ns	
t _{WICL}	Input Register Clock Width		LOW	7.5		7.5		10	ns	
t _{WICH}			HIGH	7.5		7.5		10	ns	
f _{MAXIR}	Maximum Input Register Frequency		1/(t _{WICL} + t _{WICH})	66.5		66.5		50	MHz	
t _{SIL}	Input Latch Setup Time			2.5		2.5		2.5	ns	
t _{HIL}	Input Latch Hold Time			3		3.5		4	ns	
t _{IGO}	Input Latch Gate to Combinatorial Output			20.5		24		30	ns	
t _{IGOL}	Input Latch Gate to Output Through Transparent Output Latch			23		26.5		32.5	ns	
t _{SLL}	Setup Time from Input, I/O, or Feedback Through Transparent Input Latch to Output Latch Gate			11		14.5		18	ns	
t _{IGS}	Input Latch Gate to Output Latch Setup			16		19.5		25.5	ns	
t _{WIGL}	Input Latch Gate Width LOW			7.5		7.5		10	ns	
t _{PDLL}	Input, I/O, or Feedback to Output Through Transparent Input and Output Latches			19.5		23		29	ns	

**SWITCHING CHARACTERISTICS over INDUSTRIAL operating ranges (Note 2)
(continued)**

Parameter Symbol	Parameter Description	-14		-18		-24		Unit
		Min	Max	Min	Max	Min	Max	
t _{AR}	Asynchronous Reset to Registered or Latched Output		19.5		24		30	ns
t _{ARW}	Asynchronous Reset Width (Note 1)	14.5		18		24		ns
t _{ARR}	Asynchronous Reset Recovery Time (Note 1)	10		12		18		ns
t _{AP}	Asynchronous Preset to Registered or Latched Output		19.5		24		30	ns
t _{APW}	Asynchronous Preset Width (Note 1)	14.5		18		24		ns
t _{APR}	Asynchronous Preset Recovery Time (Note 1)	10		12		18		ns
t _{EA}	Input, I/O, or Feedback to Output Enable (Note 3)		14.5		18		24	ns
t _{ER}	Input, I/O, or Feedback to Output Disable (Note 3)		14.5		18		24	ns

Notes:

1. These parameters are not 100% tested, but are evaluated at initial characterization and at any time the design is modified where frequency may be affected.
2. See Switching Test Circuit for test conditions.
3. Parameters measured with 24 outputs switching.

TYPICAL CURRENT VS. VOLTAGE (I-V) CHARACTERISTICS

$V_{CC} = 5.0\text{ V}$, $T_A = 25^\circ\text{C}$

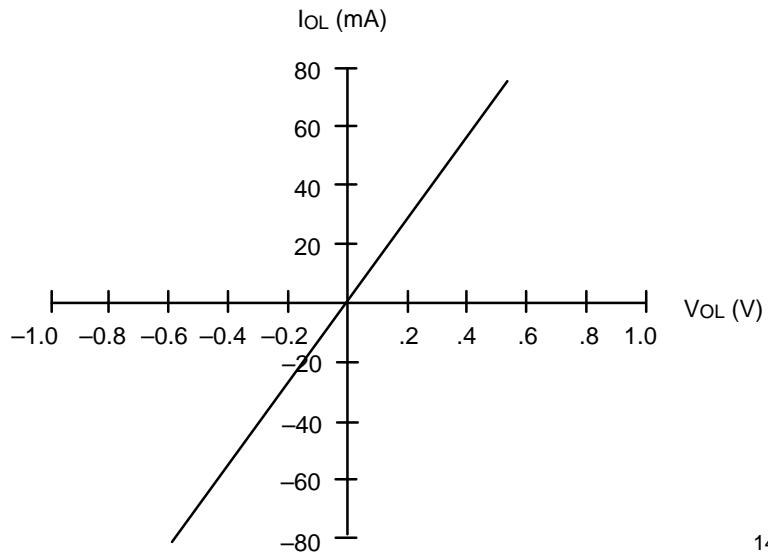

Output, LOW

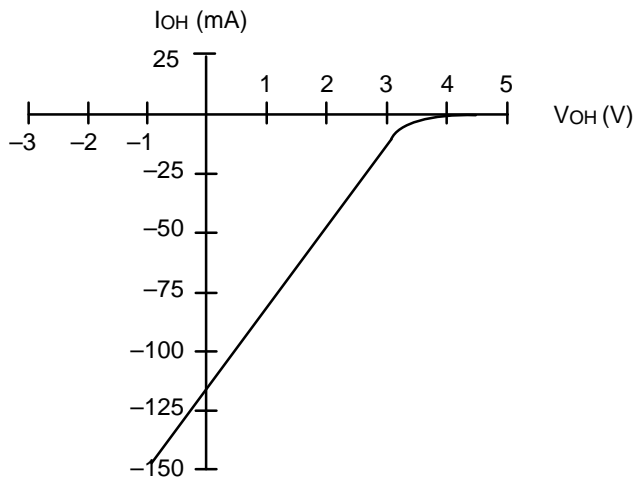

Output, HIGH

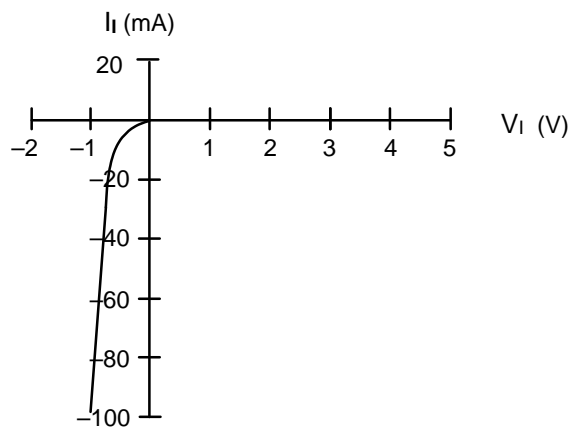

Input

TYPICAL I_{CC} CHARACTERISTICS

$V_{CC} = 5\text{ V}$, $T_A = 25^\circ\text{C}$

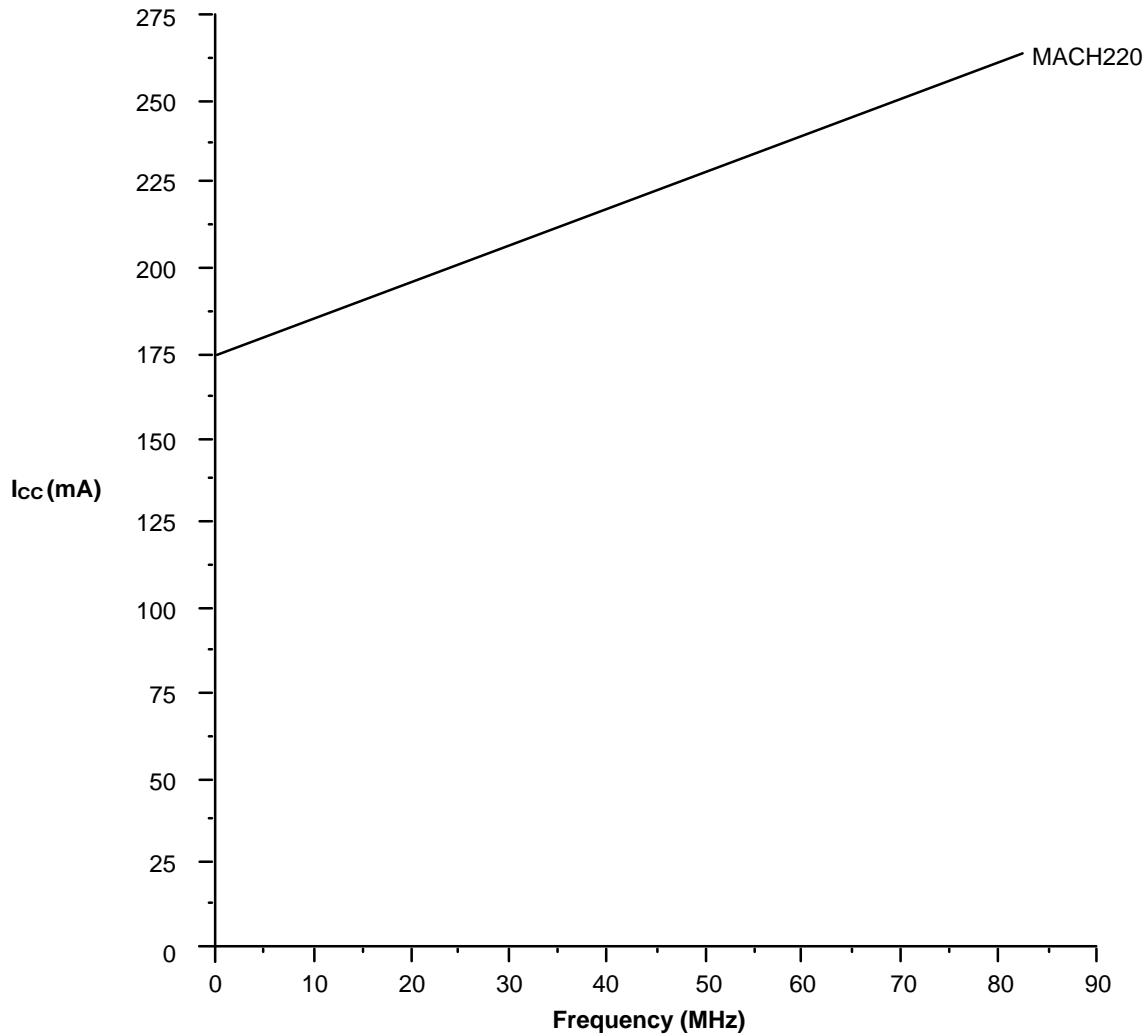

14130I-7

The selected "typical" pattern is a 12-bit up/down counter. This pattern is programmed in each PAL block and is capable of being loaded, enabled, and reset.

Maximum frequency shown uses internal feedback and a D-type register.

TYPICAL THERMAL CHARACTERISTICS

Measured at 25°C ambient. These parameters are not tested.

Parameter Symbol	Parameter Description	Typ	Units	
		PLCC		
θ_{jc}	Thermal impedance, junction to case	10	°C/W	
θ_{ja}	Thermal impedance, junction to ambient	33	°C/W	
θ_{jma}	Thermal impedance, junction to ambient with air flow	200 lfpm air	29	°C/W
		400 lfpm air	27	°C/W
		600 lfpm air	24	°C/W
		800 lfpm air	23	°C/W

Plastic θ_{jc} Considerations

The data listed for plastic θ_{jc} are for reference only and are not recommended for use in calculating junction temperatures. The heat-flow paths in plastic-encapsulated devices are complex, making the θ_{jc} measurement relative to a specific location on the package surface. Tests indicate this measurement reference point is directly below the die-attach area on the bottom center of the package. Furthermore, θ_{jc} tests on packages are performed in a constant-temperature bath, keeping the package surface at a constant temperature. Therefore, the measurements can only be used in a similar environment.

SWITCHING WAVEFORMS

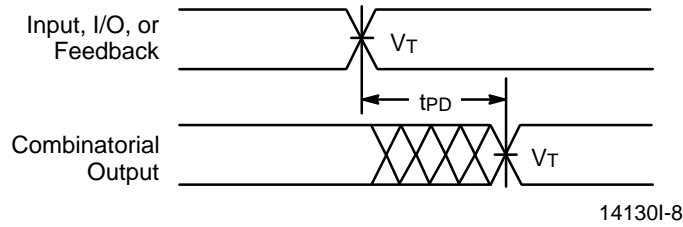

Combinatorial Output

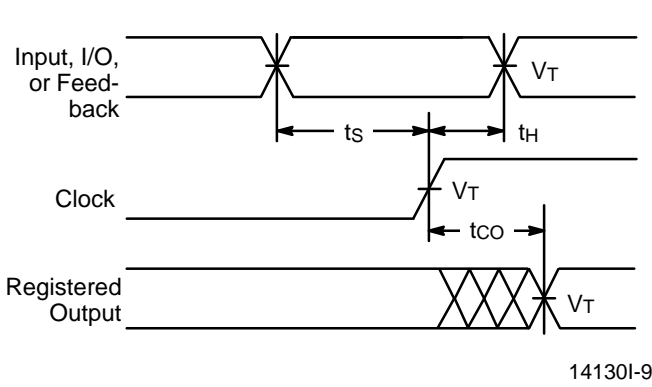

Registered Output

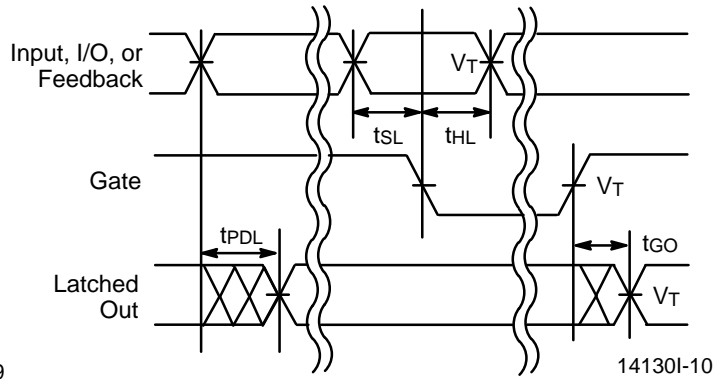

Latched Output (MACH 2, 3, and 4)

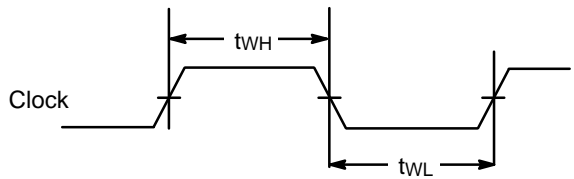

Clock Width

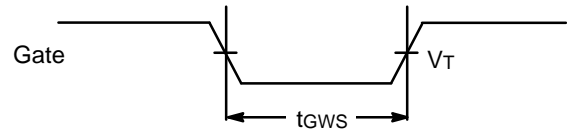

Gate Width (MACH 2, 3, and 4)

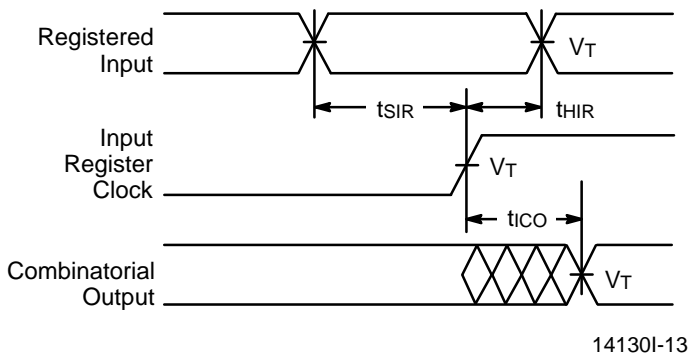

Registered Input (MACH 2 and 4)

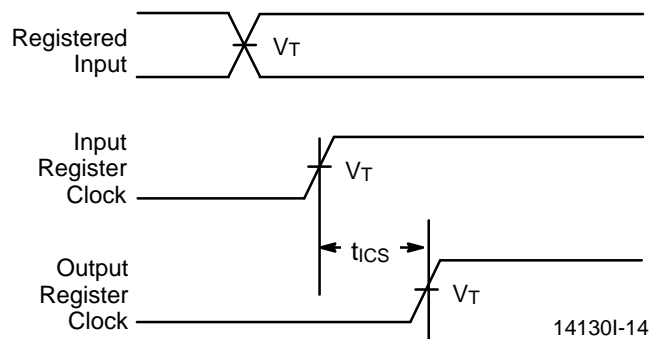

Input Register to Output Register Setup (MACH 2 and 4)

Notes:

1. $V_T = 1.5\text{ V}$.
2. Input pulse amplitude 0 V to 3.0 V.
3. Input rise and fall times 2 ns–4 ns typical.

SWITCHING WAVEFORMS

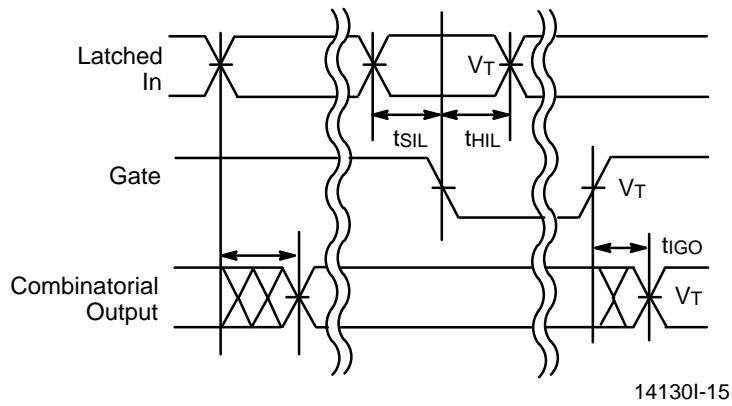

Latched Input (MACH 2 and 4)

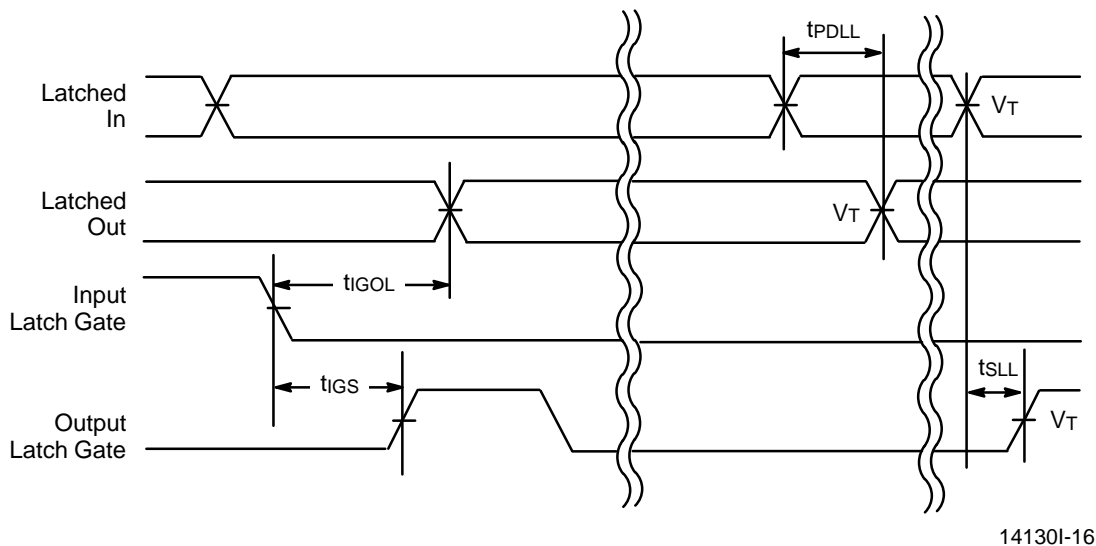

Latched Input and Output
(MACH 2, 3, and 4)

Notes:

1. $V_T = 1.5 \text{ V}$.
2. Input pulse amplitude 0 V to 3.0 V.
3. Input rise and fall times 2 ns–4 ns typical.

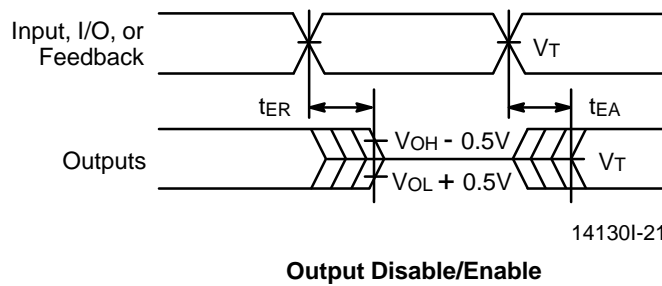
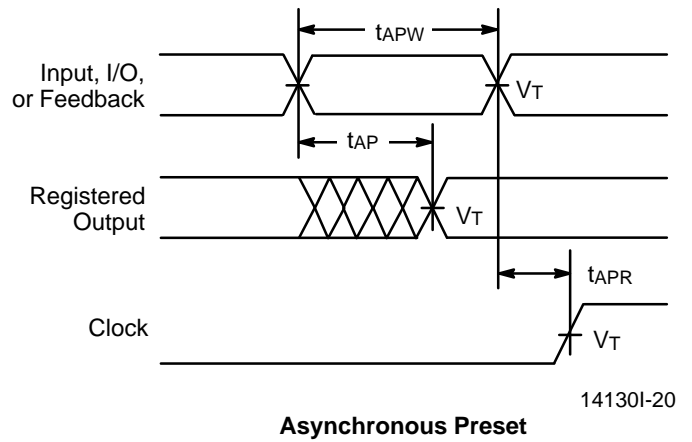
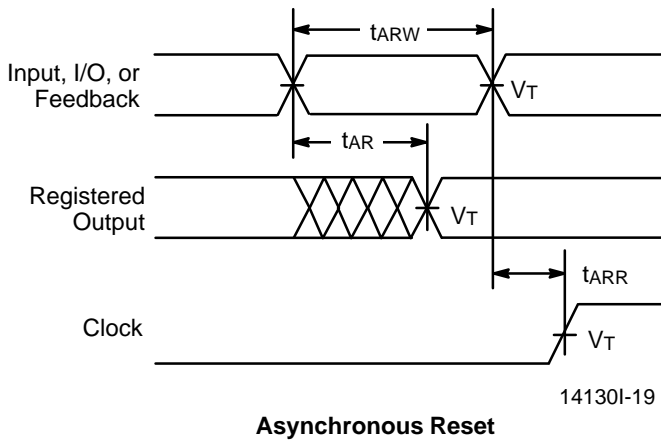
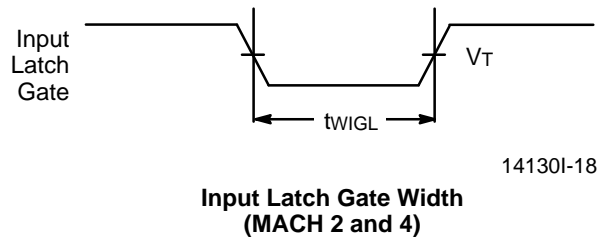
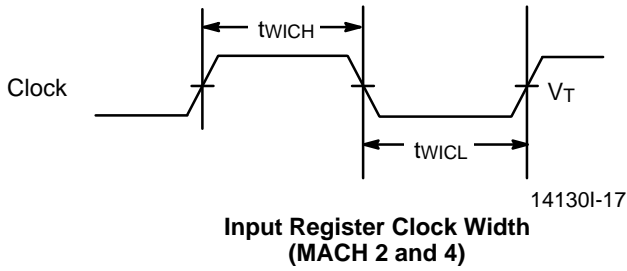

SWITCHING WAVEFORMS



Notes:

1. $V_T = 1.5 V$.
2. Input pulse amplitude 0 V to 3.0 V.
3. Input rise and fall times 2 ns–4 ns typical.

KEY TO SWITCHING WAVEFORMS

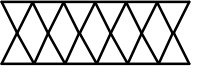
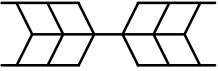
WAVEFORM	INPUTS	OUTPUTS
	Must be Steady	Will be Steady
	May Change from H to L	Will be Changing from H to L
	May Change from L to H	Will be Changing from L to H
	Don't Care, Any Change Permitted	Changing, State Unknown
	Does Not Apply	Center Line is High-Impedance "Off" State

KS000010-PAL

SWITCHING TEST CIRCUIT

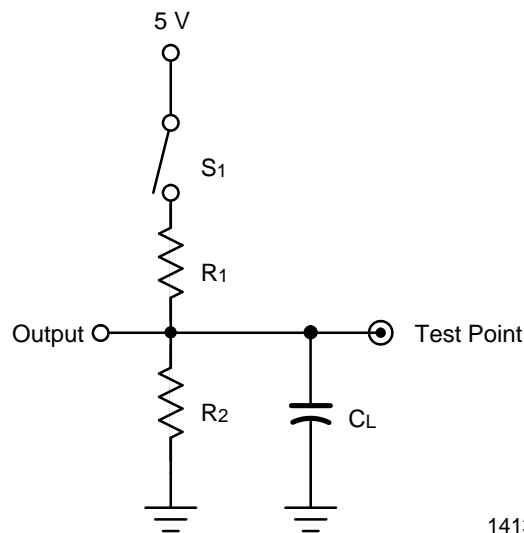

14130I-22

Specification	S ₁	C _L	Commercial		Measured Output Value
			R ₁	R ₂	
t _{PD} , t _{CO}	Closed	35 pF	300 Ω	390 Ω	1.5 V
t _{EA}	Z → H: Open Z → L: Closed				1.5 V
t _{ER}	H → Z: Open L → Z: Closed	5 pF			H → Z: V _{OH} - 0.5 V L → Z: V _{OL} + 0.5 V

*Switching several outputs simultaneously should be avoided for accurate measurement.

f_{MAX} PARAMETERS

The parameter f_{MAX} is the maximum clock rate at which the device is guaranteed to operate. Because the flexibility inherent in programmable logic devices offers a choice of clocked flip-flop designs, f_{MAX} is specified for three types of synchronous designs.

The first type of design is a state machine with feedback signals sent off-chip. This external feedback could go back to the device inputs, or to a second device in a multi-chip state machine. The slowest path defining the period is the sum of the clock-to-output time and the input setup time for the external signals (t_s + t_{CO}). The reciprocal, f_{MAX}, is the maximum frequency with external feedback or in conjunction with an equivalent speed device. This f_{MAX} is designated "f_{MAX} external."

The second type of design is a single-chip state machine with internal feedback only. In this case, flip-flop inputs are defined by the device inputs and flip-flop outputs. Under these conditions, the period is limited by the internal delay from the flip-flop outputs through the internal feedback and logic to the flip-flop inputs. This f_{MAX} is designated "f_{MAX} internal". A simple internal counter is a good example of this type of design; therefore, this parameter is sometimes called "f_{CNT}."

The third type of design is a simple data path application. In this case, input data is presented to the flip-flop and clocked through; no feedback is employed. Under these conditions, the period is limited by the sum of the data setup time and the data hold time (t_s + t_H). However, a lower limit for the period of each f_{MAX} type is the minimum clock period (t_{WH} + t_{WL}). Usually, this minimum clock period determines the period for the third f_{MAX}, designated "f_{MAX} no feedback."

For devices with input registers, one additional f_{MAX} parameter is specified: f_{MAXIR}. Because this involves no feedback, it is calculated the same way as f_{MAX} no feedback. The minimum period will be limited either by the sum of the setup and hold times (t_{SIR} + t_{HIR}) or the sum of the clock widths (t_{WICL} + t_{WICH}). The clock widths are normally the limiting parameters, so that f_{MAXIR} is specified as 1/(t_{WICL} + t_{WICH}). Note that if both input and output registers are used in the same path, the overall frequency will be limited by t_{ICS}.

All frequencies except f_{MAX} internal are calculated from other measured AC parameters. f_{MAX} internal is measured directly.

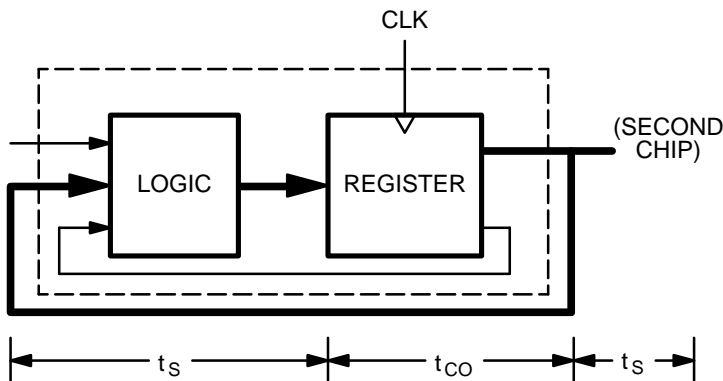

f_{MAX} External; 1/(t_s + t_{CO})

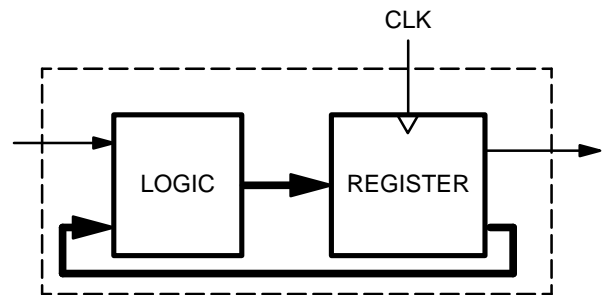

f_{MAX} Internal (f_{CNT})

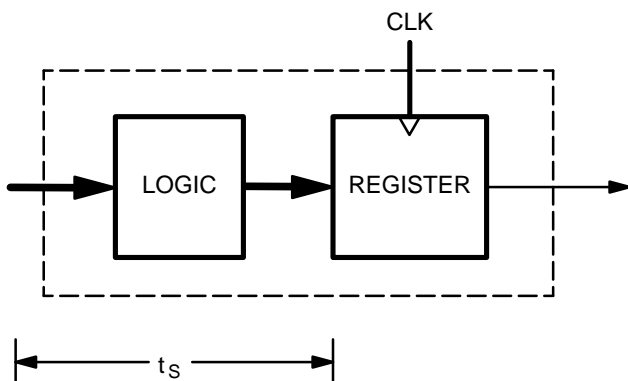

f_{MAX} No Feedback; 1/(t_s + t_H) or 1/(t_{WH} + t_{WL})

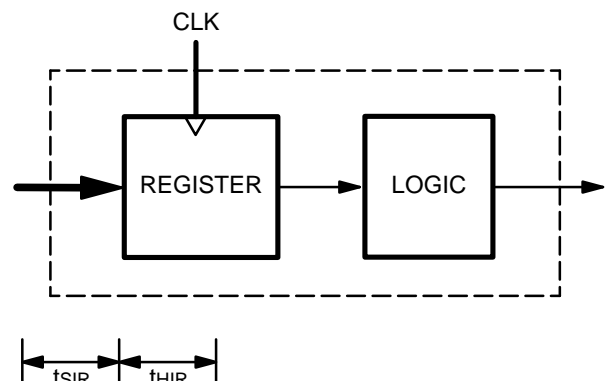

f_{MAXIR} ; 1/(t_{SIR} + t_{HIR}) or 1/(t_{WICL} + t_{WICH})

ENDURANCE CHARACTERISTICS

The MACH families are manufactured using our advanced Electrically Erasable process. This technology uses an EE cell to replace the fuse link used in

bipolar parts. As a result, the device can be erased and reprogrammed, a feature which allows 100% testing at the factory.

Endurance Characteristics

Parameter Symbol	Parameter Description	Min	Units	Test Conditions
t _{DR}	Min Pattern Data Retention Time	10	Years	Max Storage Temperature
		20	Years	Max Operating Temperature
N	Max Reprogramming Cycles	100	Cycles	Normal Programming Conditions

INPUT/OUTPUT EQUIVALENT SCHEMATICS

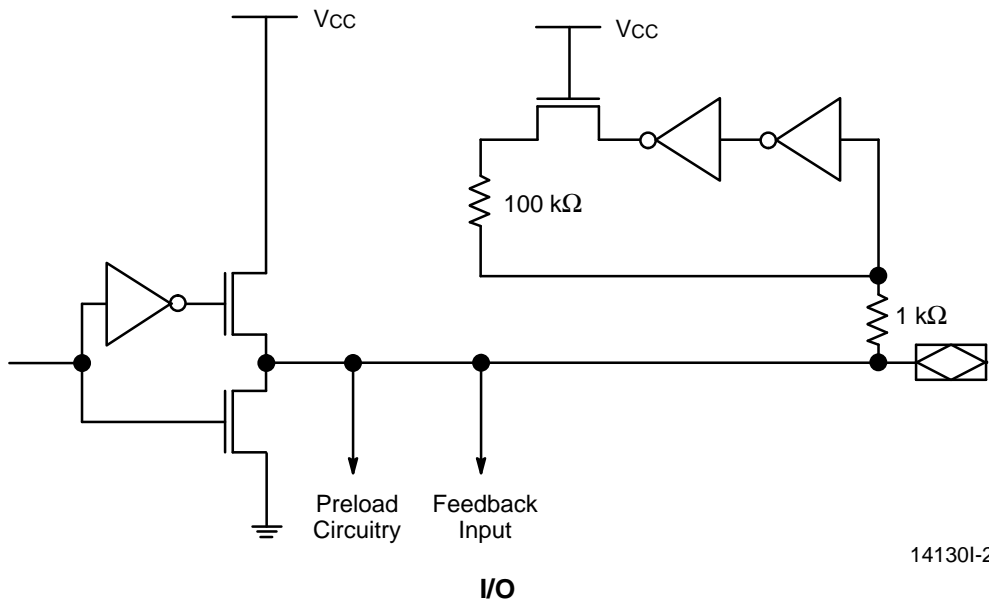
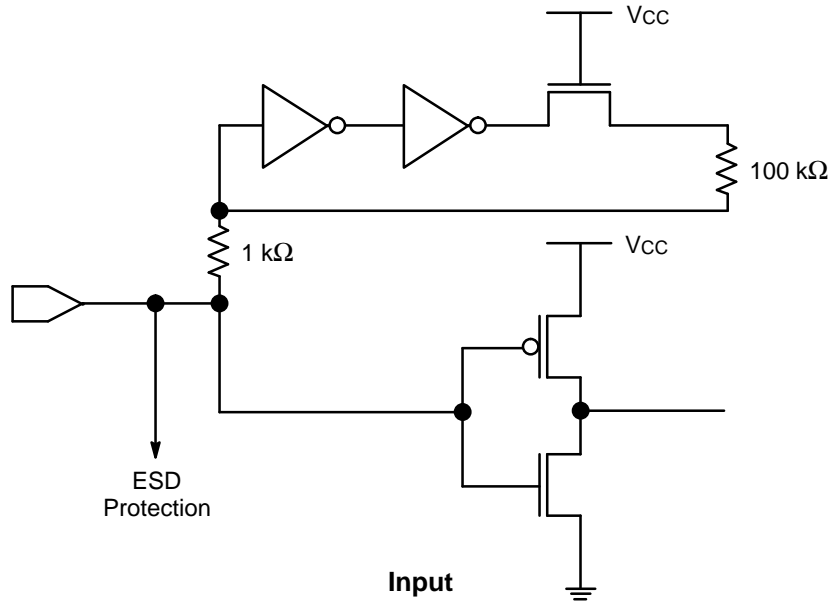

14130I-24

POWER-UP RESET

The MACH devices have been designed with the capability to reset during system power-up. Following power-up, all flip-flops will be reset to LOW. The output state will depend on the logic polarity. This feature provides extra flexibility to the designer and is especially valuable in simplifying state machine initialization. A timing diagram and parameter table are shown below. Due to the synchronous operation of the power-up reset and the

wide range of ways V_{CC} can rise to its steady state, two conditions are required to insure a valid power-up reset. These conditions are:

1. The V_{CC} rise must be monotonic.
2. Following reset, the clock input must not be driven from LOW to HIGH until all applicable input and feedback setup times are met.

Parameter Symbol	Parameter Descriptions	Max	Unit
t_{PR}	Power-Up Reset Time	10	μs
t_s	Input or Feedback Setup Time	See Switching Characteristics	
t_{WL}	Clock Width LOW	See Switching Characteristics	

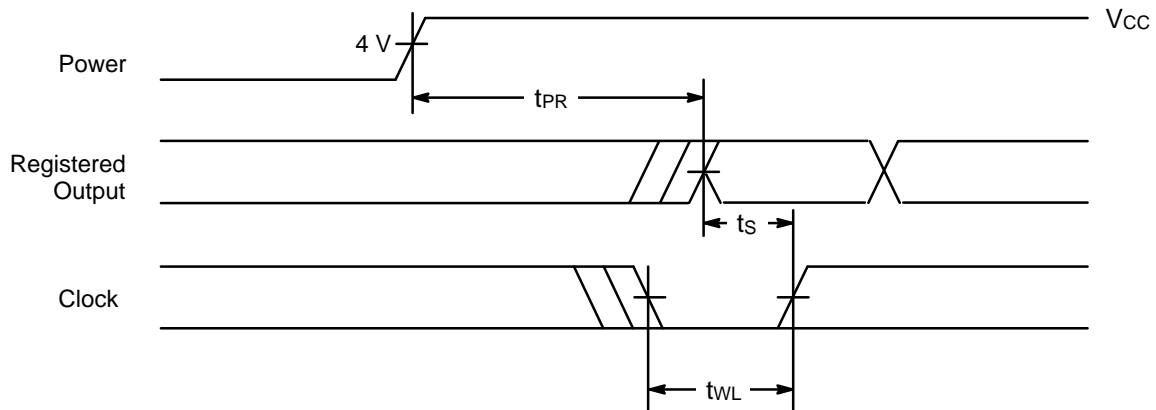

14130I-25

Power-Up Reset Waveform

USING PRELOAD AND OBSERVABILITY

In order to be testable, a circuit must be both controllable and observable. To achieve this, the MACH devices incorporate register preload and observability.

In preload mode, each flip-flop in the MACH device can be loaded from the I/O pins, in order to perform functional testing of complex state machines. Register preload makes it possible to run a series of tests from a known starting state, or to load illegal states and test for proper recovery. This ability to control the MACH device's internal state can shorten test sequences, since it is easier to reach the state of interest.

The observability function makes it possible to see the internal state of the buried registers during test by overriding each register's output enable and activating the output buffer. The values stored in output and buried registers can then be observed on the I/O pins. Without this feature, a thorough functional test would be impossible for any designs with buried registers.

While the implementation of the testability features is fairly straightforward, care must be taken in certain instances to insure valid testing.

One case involves asynchronous reset and preset. If the MACH registers drive asynchronous reset or preset lines and are preloaded in such a way that reset or preset are asserted, the reset or preset may remove the preloaded data. This is illustrated in Figure 2. Care should be taken when planning functional tests, so that states that will cause unexpected resets and presets are not preloaded.

Another case to be aware of arises in testing combinatorial logic. When an output is configured as combinatorial, the observability feature forces the output into registered mode. When this happens, all product terms are forced to zero, which eliminates all combinatorial data. For a straight combinatorial output, the correct value will be restored after the preload or observe function, and there will be no problem. If the function implements a combinatorial latch, however, it relies on feedback to hold the correct value, as shown in Figure 3. As this value may change during the preload or observe operation, you cannot count on the data being correct after the operation. To insure valid testing in these cases, outputs that are combinatorial latches should not be tested immediately following a preload or observe sequence, but should first be restored to a known state.

All MACH 2 devices support both preload and observability.

Contact individual programming vendors in order to verify programmer support.

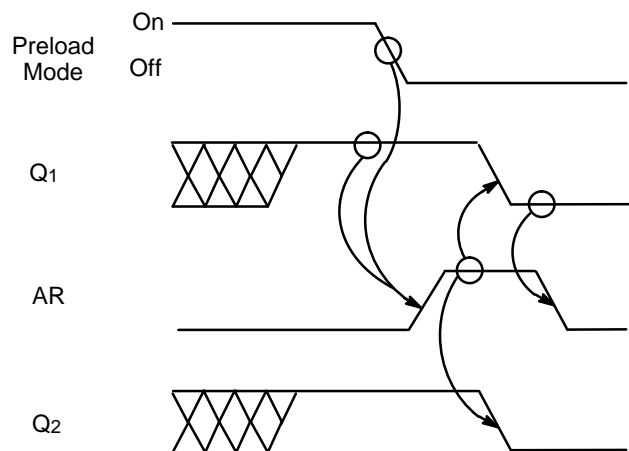
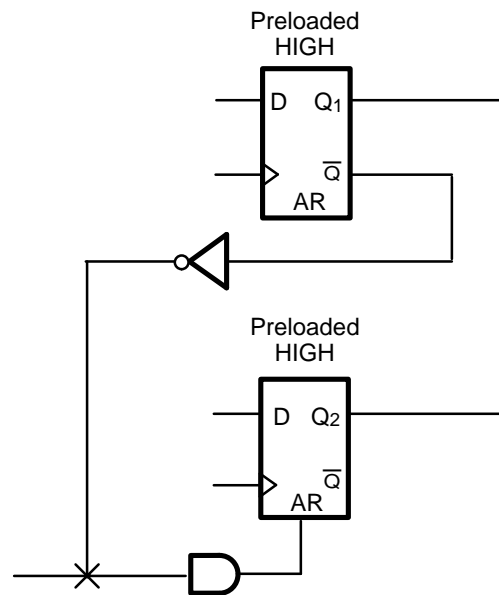

Figure 2. Preload/Reset Conflict

141301-26

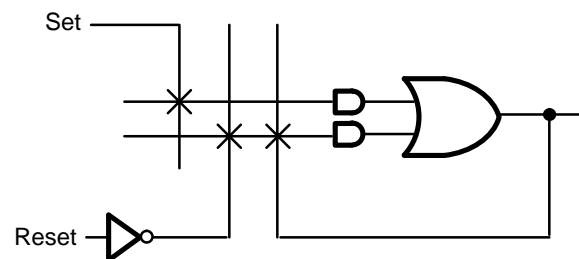

Figure 3. Combinatorial Latch

141301-27

PHYSICAL DIMENSIONS*

PL 068

68-Pin Plastic Leaded Chip Carrier (measured in inches)

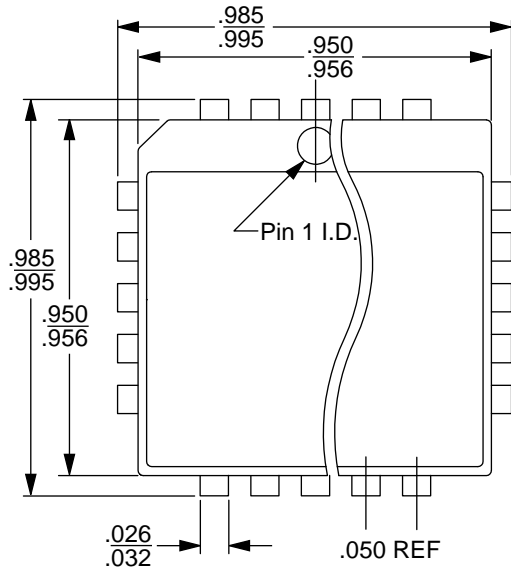

TOP VIEW

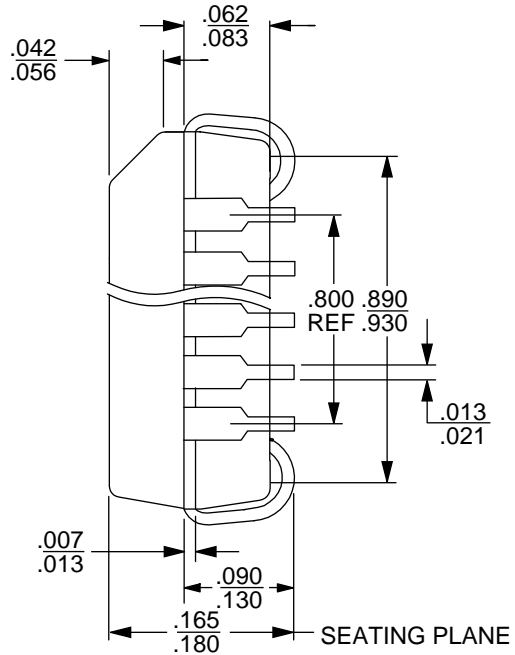

SIDE VIEW

16-038-SQ
PL 068
DA78
6-28-94 ae

*For reference only. BSC is an ANSI standard for Basic Space Centering.