

Features

- 3ns A-B switching
- 300MHz bandwidth
- Fixed gain of 2, for cable driving
- > 650V/ μ s slew rate
- TTL/CMOS compatible switch

Applications

- RGB multiplexing
- Picture-in-picture
- Cable driving
- HDTV processing
- Switched gain amplifiers
- ADC input multiplexer

Ordering Information

Part No.	Package	Tape & Reel	Outline #
EL4332CS	SO-16	-	MDP0027
EL4332CS-T7	SO-16	7 in	MDP0027
EL4332CS-T13	SO-16	13 in	MDP0027

Demo Board

A demo PCB is available for this product. Request "EL4332C/1 Demo Board."

General Description

The EL4332C is a triple very high speed 2:1 Multiplexer-Amplifier. It is intended primarily for component video multiplexing and is especially suited for pixel switching. The amplifiers have their gain set to 2 internally, which reduces the need for many external components. The gain-of-2 facilitates driving back terminated cables. All three amplifiers are switched simultaneously from their A to B inputs by the TTL/CMOS compatible, common A/B control pin.

A -3dB bandwidth of 300MHz together with 3ns multiplexing time enable the full performance of the fastest component video systems to be realized.

The EL4332C runs from standard $\pm 5V$ supplies, and is available in the narrow 16-pin small outline package.

Connection Diagrams

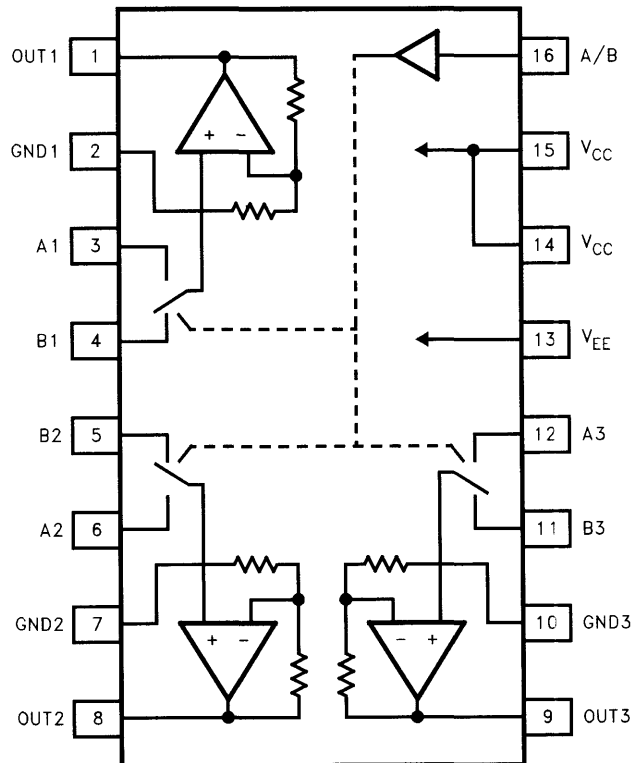

Absolute Maximum Ratings (T_A = 25 °C)

V _{CC} to V _{EE}	14V	Input Current, Any Input	5mA
V _{CC} to any GND	12V	Power Dissipation	See Curves
V _{EE} to any GND	12V	Operating Temperature	-40°C to 85°C
Continuous Output Current	45mA	Junction Temperature	170°C
Any Input	V _{EE} - 0.3V to V _{CC} + 0.3V	Storage Temperature	-60°C to +150°C

Important Note:

All parameters having Min/Max specifications are guaranteed. Typ values are for information purposes only. Unless otherwise noted, all tests are at the specified temperature and are pulsed tests, therefore: T_J = T_C = T_A

DC Electrical Characteristics

V_{CC} = +5V, V_{EE} = -5V, Temperature = 25°C, R_L = ∞

Parameter	Description	Min	Typ	Max	Units
V _{OS}	Input Referred Offset Voltage		8	20	mV
dV _{OS}	Input Referred Offset Voltage Delta ^[1]		2	8	mV
R _{IN}	Input Resistance		30		kΩ
I _B	Input Bias Current		-7	-30	μA
dI _B	Input Bias Current Delta ^[1]		0.5	4.0	μA
A _V	Gain	1.94	2.00	2.06	V/V
dA _V	Gain Delta ^[1]		0.5	2.5	%
C _{IN}	Input Capacitance		3.3		pF
PSRR	Power Supply Rejection Ratio	50	70		dB
V _O	Output Voltage Swing into 500Ω load	±2.7	±3.6		V
	Output Voltage Swing into 150Ω load		+3/-2.7		V
I _{OUT}	Current Output, Measured with 75W Load ^[2]	30	40		mA
Xtalk _{AB}	Crosstalk from Non-selected Input (at DC)	-70	-100		dB
Xtalk _{CH-CH}	Crosstalk from one Amplifier to another Amplifier	-70	-100		dB
V _{IH}	Input Logic High Level	2.0			V
V _{IL}	Input Logic Low Level			0.8	V
I _{IL}	Logic Low Input Current (V _{IN} = 0V)	-0.3	-40	-80	μA
I _{IH}	Logic High Input Current (V _{IN} = 0V)	-3	0	3	μA
I _S	Total Supply Current	38	48	60	mA

1. Each channel's A-input to its B-input.
2. There is no short circuit protection on any output.

AC Electrical Characteristics

V_{CC} = +5V, V_{EE} = -5V, Temperature = 25°C, R_L = 150Ω, C_L = 3pF.

Parameter	Description	Min	Typ	Max	Units
BW	-3dB Bandwidth		300		MHz
BW 0.1dB	±0.1dB Bandwidth		105		MHz
DG	Differential Gain at 3.58MHz		0.04		%
DP	Differential Phase at 3.58MHz		0.08		°
Pkg	Peaking with Nominal Load		0.2		dB
SR	Slew Rate (4V Square Wave, Measured 25%–75%)		650		V/μs

EL4332C**Triple 2:1 300MHz Mux-Amp AV =2****AC Electrical Characteristics** $V_{CC} = +5V$, $V_{EE} = -5V$, Temperature = 25°C, $R_L = 150\Omega$, $C_L = 3pF$.

Parameter	Description	Min	Typ	Max	Units
t_s	Settling Time to 0.1% of Final Value		13		ns
T_{SW}	Time to Switch Inputs		3		ns
OS	Overshoot, $V_{OUT} = 4V_{P-P}$		8		%
I_{SOab}	10M	Input to Input Isolation at 10MHz	60		dB
	100M	Input to Input Isolation at 100MHz	40		dB
$I_{SOch-ch}$	10M	Channel to Channel Isolation at 10MHz	61		dB
	100M	Channel to Channel Isolation at 100MHz	50		dB

Pin Descriptions

Pin Name	Function
A1, A2, A3	"A" inputs to amplifiers 1, 2 and 3 respectively
B1, B2, B3	"B" inputs to amplifiers 1, 2 and 3 respectively
GND1, GND2, GND3	These are the individual ground pins for each channel.
Out1, Out2, Out3	Amplifier outputs. Note: there is no short circuit protection on any output.
V_{CC}	Positive power supply. Typically +5V.
V_{EE}	Negative power supply. Typically -5V.
A/B	Common input select pin, a logic high selects the "A" inputs, logic low selects the "B" inputs. CMOS/TTL compatible.

Burn In Schematic

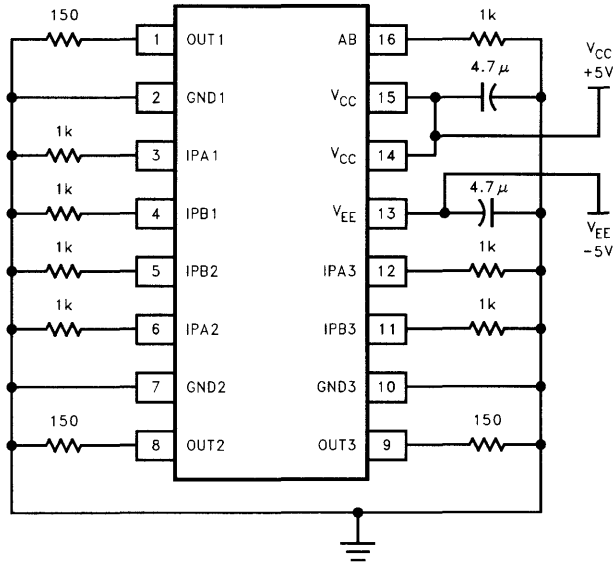

Video

EL4332C

Triple 2:1 300MHz Mux-Amp AV =2

Typical Performance Curves

Small Signal Transient Response

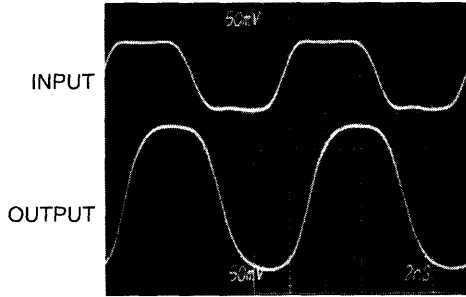

Large Signal Transient Response

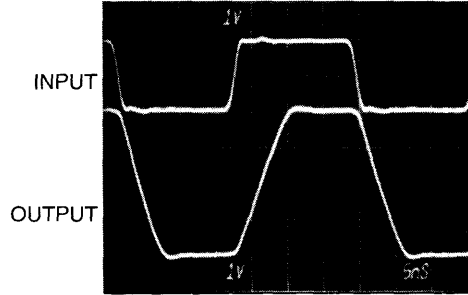

Switching to Ground from a Large Signal Uncorrelated Sine Wave

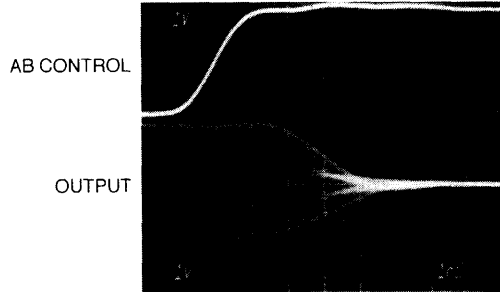

Switching from Ground to a Large Signal Uncorrelated Sine Wave

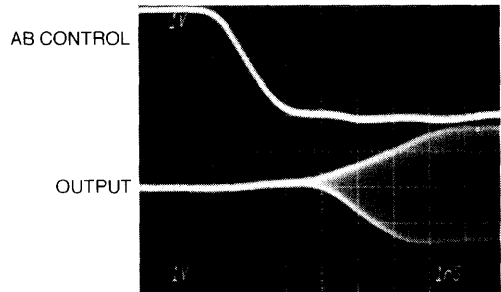

Switching to Ground from a Small Signal Uncorrelated Sine Wave

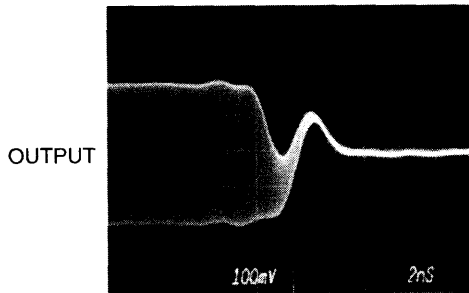

Switching from Ground to a Small Signal Uncorrelated Sine Wave

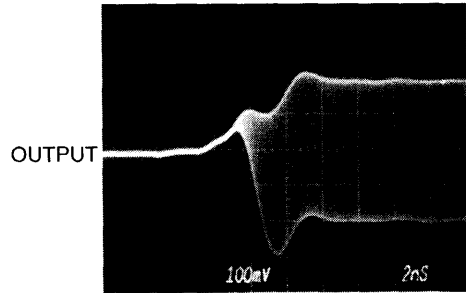

Switching Glitch
(Inputs at Ground)

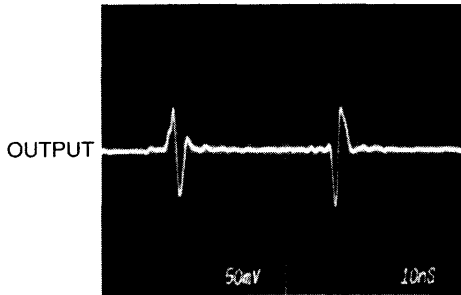

Switching from a Family of DC Levels to Ground

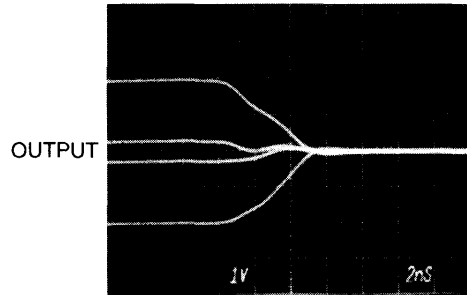

Switching from Ground to a Family of DC Levels

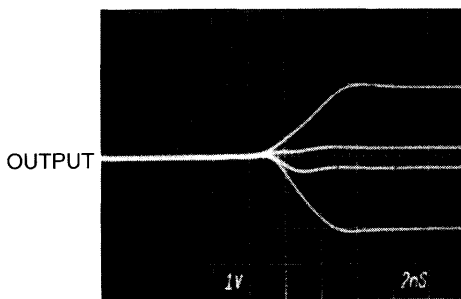

Channel A/B Switching Delay

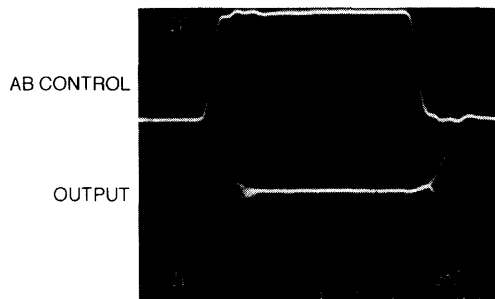

Gain vs Frequency

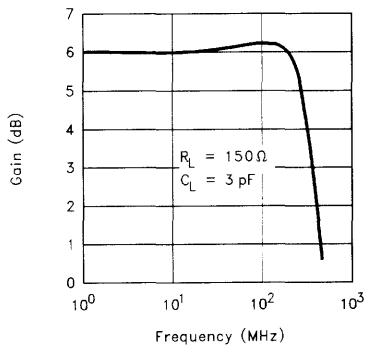

Gain vs Frequency

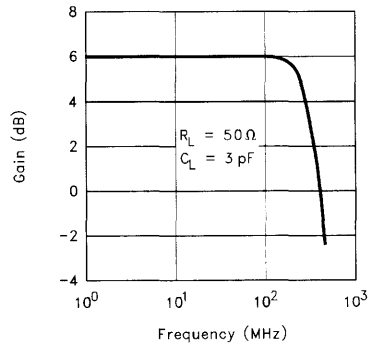

EL4332C

Triple 2:1 300MHz Mux-Amp AV =2

-3dB BW vs Supply Voltage

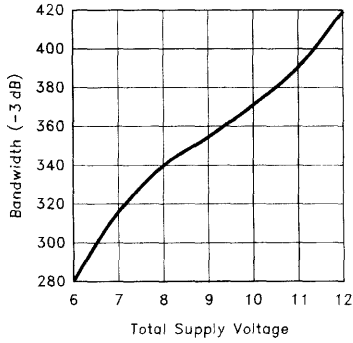

Bandwidth vs Die Temperature

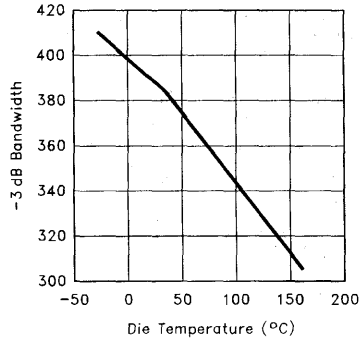

Frequency Response with Capacitive Loads

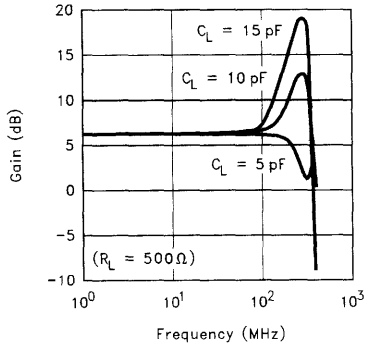

Input Voltage Noise over Frequency

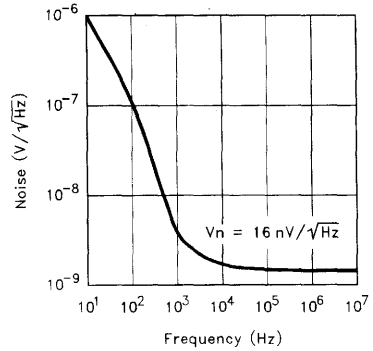

A-Input to B-Input Isolation

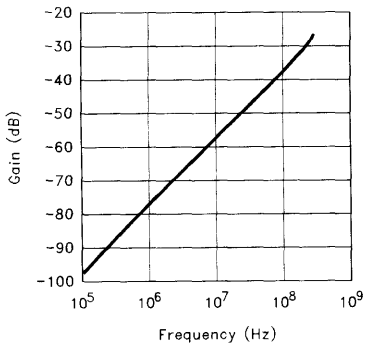

Channel-Channel Isolation

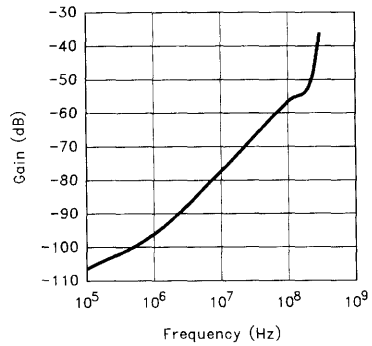

Output Swing vs Supply Voltage

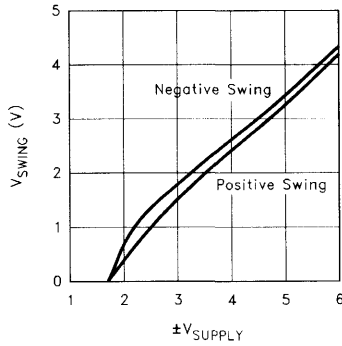

Slew Rate vs Supply Voltage

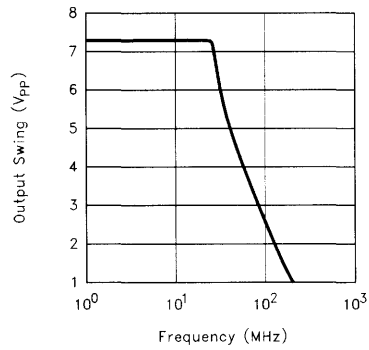

Supply Current vs Supply Voltage

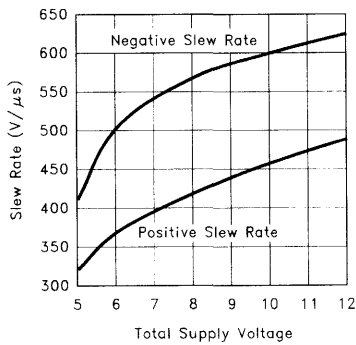

Slew Rate vs Die Temperature

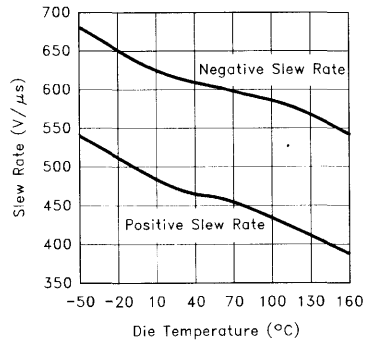

A-Input to B-Input Isolation

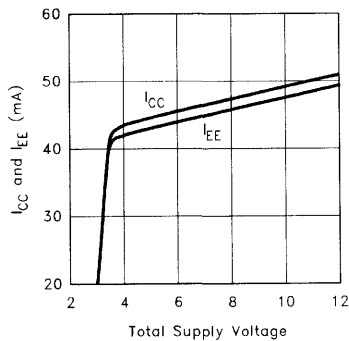

Maximum Power Dissipation

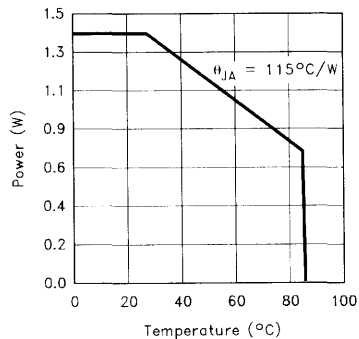

EL4332C**Triple 2:1 300MHz Mux-Amp AV =2****Applications**

Figure 1 shows a typical use for the EL4332C. The circuit is a component video (R,G,B or Y,U,V) multiplexer. Since the gain of the internal amplifiers has been set to 2, the only extra components needed are the

supply decoupling capacitors and the back terminating resistors, if transmission lines are to be driven. The EL4332C can drive backmatched 50Ω or 75Ω loads.

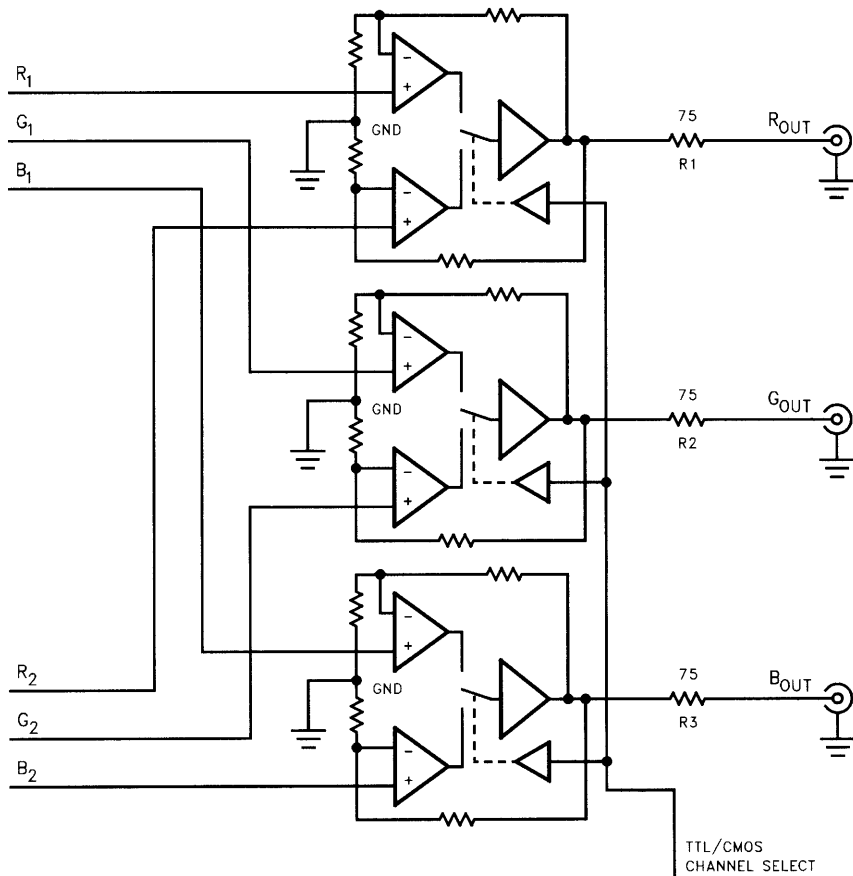

Figure 1. Typical Connection for a 2:1 Component Video Multiplexer

Grounds

It will be noticed that each mux-amp channel has its own separate ground pin. These ground pins have been kept separate to keep the channel separation inside the chip as large as possible. The feedback resistors use these ground pins as their reference. The resistors total 400Ω , so there is a significant signal current flowing from these pins to ground.

The ground pins should all be connected together, to a ground plane underneath the chip. 1 oz. copper for the ground plane is highly recommended.

Further notes and recommended practices for high speed printed circuit board layout can be found in the tutorials in the Elantec databooks.

Supplies

Supply bypassing should be as physically near the power pins as possible. Chip capacitors should be used to minimize lead inductance. Note that larger values of capacitor tend to have larger internal inductances. So when designing for 3 transmission lines or similar moderate loads, a $0.1\mu\text{F}$ ceramic capacitor right next to the power pin in parallel with a $22\mu\text{F}$ tantalum capacitor placed as close to the $0.1\mu\text{F}$ is recommended. For lighter loadings, or if not all the channels are being used, a single $4.7\mu\text{F}$ capacitor has been found quite adequate.

Note that component video signals do tend to have a high level of signal correlation. This is especially true if the video signal has been derived from 3 synchronously clocked DACs. This corresponds to all three channels drawing large slew currents simultaneously from the supplies. Thus, proper bypassing is critical.

Logic Inputs

The A/B select, logic input, is internally referenced to ground. It is set at 2 diode drops above ground, to give a threshold of about 1.4V (see Figure 2). The PNP input transistor requires that the driving gate be able to sink

current, typically $<30\mu\text{A}$, for a logic "low". If left to float, it will be a logic "high".

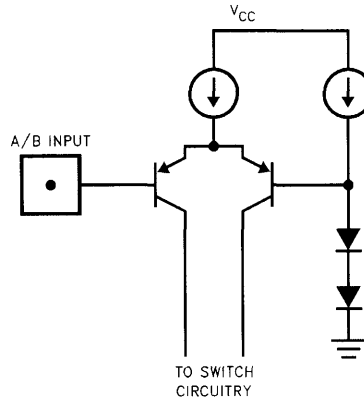

Figure 2. Simplified Logic Input Stage

The input PNP transistors have sufficient gain that a simple level shift circuit (see Figure 3) can be used to provide a simple interface with Emitter Coupled Logic. Typically, 200mV is enough to switch from a solid logic "low" to a "high."

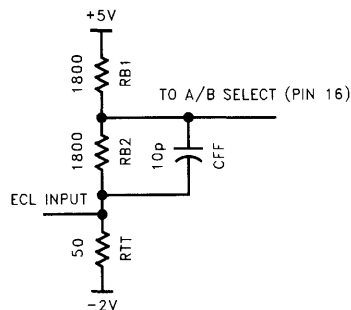

Figure 3. Adapting the Select Pin for ECL Logic Levels

The capacitor C_{ff} is only in the network to prevent the A/B pin's capacitance from slowing the control signal. The network shown level shifts the ECL levels, -0.7V to -1.5V to $+1.6\text{V}$ and $+1.1\text{V}$ respectively. The terminating resistor, R_{tt} , is required since the open emitter of the ECL gate can not sink current. If a -2V rail is not being

EL4332C**Triple 2:1 300MHz Mux-Amp AV =2**

used, a 220Ω to 330Ω resistor to the -5.2V rail would have the same effect.

Expanding the Multiplexer

In Figure 4, a 3:1 multiplexer circuit is shown. The expansion to more inputs is very straight forward. Since the EL4332C has a fixed gain of 2, interstage attenuators may be required as shown in Figure 3. The truth table for the 3:1 multiplexer select lines is:

X	Y	Mux Output
0	0	R3, G3, B3
0	1	R2, G2, B2
1	X	R1, G1, B1

When interstage attenuators are used, the values should be kept down in the region of 50Ω–300Ω. This is to prevent a combination of circuit board stray capacitance and the EL4332C's input capacitance forming a significant pole. For example, if instead of 100Ω as shown, resistors of 1kΩ had been used, and assuming 3pF of stray and 3pF of input capacitance, a pole would be formed at about 53MHz.

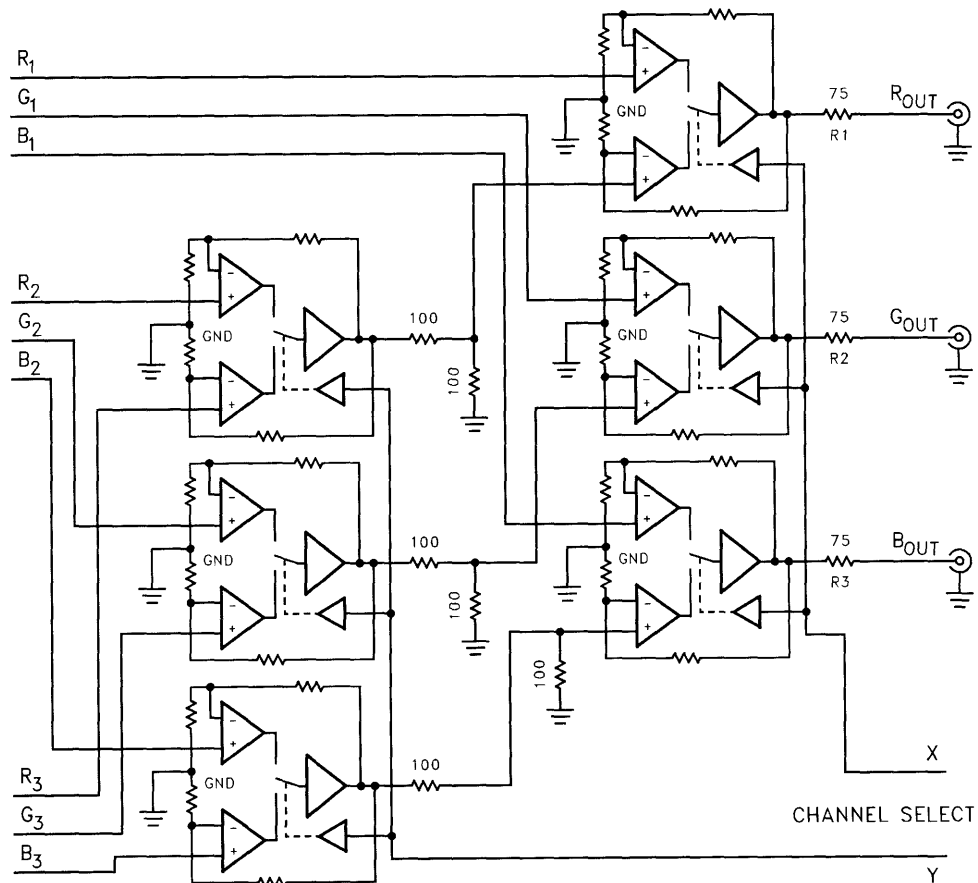

Figure 4. Typical Connection for a 3:1 Component Video Multiplexer

A Bandwidth Selectable Circuit

In Figure 5, a circuit is shown that allows three signals to be either low pass filtered or full bandwidth.

This could be useful where an input signal is frequently noisy. The component values shown

give a Butterworth LPF response, with a -3dB frequency of 50MHz. Note again, the resistor values are low, so that stray capacitance does not affect the desired cut-off frequency.

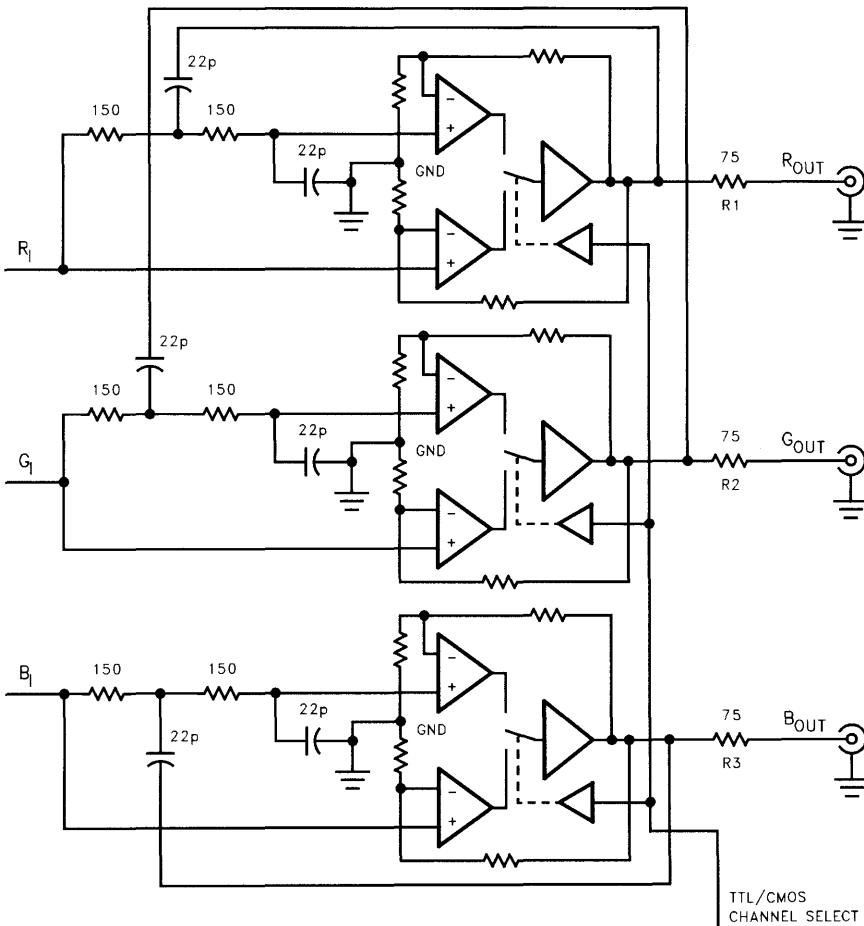

Figure 5. Switched 50MHz Low Pass Filter for High/Low Resolution Monitors

Video

EL4332C

Triple 2:1 300MHz Mux-Amp AV =2

EL4332C Macromodel

* EL4332C Macromodel
 * Revision A, April 1996

 *Applications Hints. The EL4332C has two V_{CC} pins, one V_{EE} pin, and three ground pins. The V_{CC} pins (pins 14 and 15 are internally shorted together in the model, but the ground pins (GND1, GND2, and GND3 (nodes 2, 7, and 10, respectively) *must be connected to ground (node 0) using a 1e-6W resistor. Alternatively, * nodes 2, 7, and 10 may be connected to ground through a 25 Ω resistor in parallel * with a 4 nH inductor to simulate package and PCB parasitics.

* Connections:

```

* OUT1
* |
* | GND1
* | |
* | | A1
* | |
* | | B1
* | |
* | | B2
* | |
* | | A2
* | |
* | | GND2
* | |
* | | OUT2
* | |
* | 1 2 3 4 5 6 7 8
*
* OUT3
* |
* | GND3
* | |
* | | B3
* | |
* | | A3
* | |
* | | VEE
* | |
* | | VCC
* | |
* | | VCC
* | |
* | | A/B
* | |
* | 9 10 11 12 13 14 15 16

```

*****A B Switch *****

```

Rshort 14 15 1e-12
rshort1 15 0 100 Meg
Isw 14 110 1.5 mA
vref 111 0 1.6 V
q1 101 16 110 qp
q2 102 111 110 qp
R1 101 13 500
R2 102 13 500
Rd1 107 0 100
Esw 107 0 table {v(102, 101)*100} (0,0) (1,1)
*

```

*****Amplifier #1 *****

```

q131 103 3 112 qp
q141 104 114 113 qp
q151 105 4 115 qp
q161 106 117 116 qp
Ia11 14 112 1 mA
Ia21 14 113 1 mA
Ib11 14 115 1 mA
Ib21 14 116 1 mA
Rga1 112 113 275
Rga2 115 116 275
R31 103 13 275
R41 104 13 275
R51 105 13 275
R61 106 13 275
R71 1 114 400

```

```

R81 114 2 400
R911 117 400
R110 117 2 400
Ediff1 108 0 value {(v(104,103)*v(107))+v(106,105)*(1-v(107))}
rdiff1 108 0 1 K
*
*Compensation Section
*
ga1 0 134 108 0 1 m
rh1 134 0 5 Meg
cc1 134 0 0.6 pF
*
*Poles
*
ep1 141 0 134 0 1.0
rpa1 141 142 200
cpa1 142 0 0.75 pF
rpbl 142 143 200
cpbl 143 0 0.75 pF
*
*Output Stage
*
i011 15 150 1.0 mA
i021 151 13 1.0 mA
q71 13 143 150 qp
q81 15 143 151 qn
q91 15 150 152 qn
q101 13 151 153 qp
ros11 152 1 2
ros21 153 1 2
*
*****Amplifier #2*****
q231 203 6 212 qp
q241 204 214 213 qp
q251 205 5 215 qp
q261 206 217 216 qp
Ia12 14 212 1 mA
Ia22 14 213 1 mA
Ib12 14 215 1 mA
Ib22 14 216 1 mA
Rga2 212 213 275
Rgb2 215 216 275
R231 203 13 275
R241 204 13 275
R251 205 13 275
R261 206 13 275
R271 8 214 400
R281 214 7 400
R291 8 217 400
R210 217 7 400
Ediff2 208 0 value {(v(204,203)*v(107))+v(206,205)*(1-v(107))}
rdiff2 208 0 1 K
*
* Compensation Section
*
ga2 0 234 208 0 1 m
rh2 234 0 5 Meg
cc2 234 0 0.6 pF
*
* Poles
*
ep2 241 0 234 0 1.0
rpa2 241 242 200
cpa2 242 0 0.75 pF

```

EL4332C**Triple 2:1 300MHz Mux-Amp AV =2**

```

rpb2 242 243 200
cpb2 243 0 0.75 pF
*
*Output Stage
*
i0 12 15 250 1.0 mA
i022 251 13 1.0 mA
q271 13 243 250 qp
q281 15 243 251 qn
q291 15 250 252 qn
q201 13 251 253 qp
ros12 252 8 2
ros22 253 8 2
*
*****Amplifier #3 *****
q331 303 12 312 qp
q341 304 314 313 qp
q351 305 11 315 qp
q361 306 317 316 qp
Ia13 14 312 1 mA
Ia23 14 313 1 mA
Ib13 14 315 1 mA
Ib23 14 316 1 mA
Rga3 312 313 275
Rgb3 315 316 275
R331 303 13 275
R341 304 13 275
R351 305 13 275
R361 306 13 275
R371 9 314 400
R381 314 10 400
R391 9 317 400
R310 317 10 400
Ediff3 308 0 value {( v(304,303)*(v(107))+(v(306,305)*(1-v(107)))}
rdiff3 308 0 1 K
*
* Compensation
*
ga3 0 334 308 01m
rh3 334 0 5 Meg
cc3 334 0 0.6 pF
*
* Poles
*
ep3 341 0 3340 1.0
rpa3 341 342 200
cpa3 342 0 0.75 pF
rpb3 342 343 200
cpb3 343 0 0.75 pF
*
* Output Stage
*
i013 15 350 1.0 mA
i023 351 13 1.0 mA
q371 13 343 350 qp
q381 15 343 351 qn
q391 15 350 352 qn
q301 13 351 353 qp
ros13 352 9 2
ros23 353 9 2
*
* Power Supply Current
*
ips 15 13 22 mA

```

EL4332C

Triple 2:1 300MHz Mux-Amp AV =2

EL4332C

```
*  
*Models  
*  
.model qp pnp(is=1.5e-16 bf=300 tf=0.01ns)  
.model qn npn(is=0.8e-18 bf=300 tf=0.01ns)  
.ends
```

Video