

April 1995

15A, 700V - 1000V Ultrafast Diodes

Features

- Ultrafast with Soft Recovery Characteristic ($t_{RR} < 100\text{ns}$)
- +175°C Rated Junction Temperature
- Reverse Voltage Up to 1000V
- Avalanche Energy Rated

Applications

- Switching Power Supply
- Power Switching Circuits
- General Purpose

Description

RURP1570, RURP1580, RURP1590, RURP15100 are ultrafast diodes with soft recovery characteristics ($t_{RR} < 100\text{ns}$). They have a low forward voltage drop and are silicon nitride passivated, ion-implanted, epitaxial construction.

These devices are intended for use as freewheel/clamping diodes and rectifiers in a variety of switching power supplies and other power switching applications. Their low stored charge and ultrafast recovery with soft recovery characteristics minimizes ringing and electrical noise in many power switching circuits thus reducing power loss in the switching transistor.

PACKAGING AVAILABILITY

PART NUMBER	PACKAGE	BRAND
RURP1570	TO-220AC	RURP1570
RURP1580	TO-220AC	RURP1580
RURP1590	TO-220AC	RURP1590
RURP15100	TO-220AC	RURP15100

NOTE: When ordering, use the entire part number.

Package

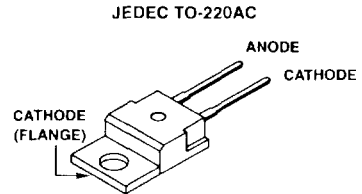

Symbol



Absolute Maximum Ratings

$T_C = +25^\circ\text{C}$, Unless Otherwise Specified

	RURP1570	RURP1580	RURP1590	RURP15100
Peak Repetitive Reverse Voltage V_{RRM}	700V	800V	900V	1000V
Working Peak Reverse Voltage V_{RWM}	700V	800V	900V	1000V
DC Blocking Voltage V_R	700V	800V	900V	1000V
Average Rectified Forward Current $I_{F(AV)}$ (Total Device Forward Current At Rated V_R And $T_C = +150^\circ\text{C}$)	15A	15A	15A	15A
Peak Forward Repetitive Current I_{FRM} (Rated V_R , Square Wave 20kHz)	30A	30A	30A	30A
Nonrepetitive Peak Surge Current I_{FSM} (Surge Applied At Rated Load Condition Halfwave 1 Phase 60Hz)	200A	200A	200A	200A
Maximum Power Dissipation P_D	100W	100W	100W	100W
Operating and Storage Temperature T_{STG}, T_J	-65°C to +175°C	-65°C to +175°C	-65°C to +175°C	-65°C to +175°C

Specifications RURP1570, RURP1580, RURP1590, RURP15100

Electrical Specifications $T_C = +25^\circ\text{C}$, Unless Otherwise Specified.

SYMBOL	TEST CONDITION	LIMITS												UNITS
		RURP1570			RURP1580			RURP1590			RURP15100			
		MIN	TYP	MAX	MIN	TYP	MAX	MIN	TYP	MAX	MIN	TYP	MAX	
V_F	$I_F = 15\text{A}$ $T_C = +150^\circ\text{C}$	-	-	1.50	-	-	1.50	-	-	1.50	-	-	1.50	V
	$I_F = 15\text{A}$ $T_C = +25^\circ\text{C}$	-	-	1.80	-	-	1.80	-	-	1.80	-	-	1.80	V
I_R at $T_C = +150^\circ\text{C}$	$V_R = 700\text{V}$	-	-	500	-	-	-	-	-	-	-	-	-	μA
	$V_R = 800\text{V}$	-	-	-	-	-	500	-	-	-	-	-	-	μA
	$V_R = 900\text{V}$	-	-	-	-	-	-	-	-	500	-	-	-	μA
	$V_R = 1000\text{V}$	-	-	-	-	-	-	-	-	-	-	-	500	μA
I_R at $T_C = +25^\circ\text{C}$	$V_R = 700\text{V}$	-	-	100	-	-	-	-	-	-	-	-	-	μA
	$V_R = 800\text{V}$	-	-	-	-	-	100	-	-	-	-	-	-	μA
	$V_R = 900\text{V}$	-	-	-	-	-	-	-	-	100	-	-	-	μA
	$V_R = 1000\text{V}$	-	-	-	-	-	-	-	-	-	-	-	100	μA
t_{RR}	$I_F = 1\text{A}$	-	-	100	-	-	100	-	-	100	-	-	100	ns
	$I_F = 15\text{A}$	-	-	125	-	-	125	-	-	125	-	-	125	ns
t_A	$I_F = 15\text{A}$	-	75	-	-	75	-	-	75	-	-	75	-	ns
t_B	$I_F = 15\text{A}$	-	40	-	-	40	-	-	40	-	-	40	-	ns
$R_{\theta JC}$		-	-	1.5	-	-	1.5	-	-	1.5	-	-	1.5	$^\circ\text{C/W}$
E_{AVL}		-	-	20	-	-	20	-	-	20	-	-	20	mj

DEFINITIONS

- V_F = Instantaneous forward voltage ($p_w = 300\mu\text{s}$, $D = 2\%$).
- I_R = Instantaneous reverse current.
- t_{RR} = Reverse recovery time at $dI_F/dt = 100\text{A}/\mu\text{s}$ (See Figure 2), summation of $t_A + t_B$.
- t_A = Time to reach peak reverse current at $dI_F/dt = 100\text{A}/\mu\text{s}$ (See Figure 2).
- t_B = Time from peak I_{RM} to projected zero crossing of I_{RM} based on a straight line from peak I_{RM} through 25% of I_{RM} (See Figure 2).
- $R_{\theta JC}$ = Thermal resistance junction to case.
- E_{AVL} = Controlled avalanche energy (See Figures 7 and 8).
- p_w = pulse width.
- D = duty cycle.

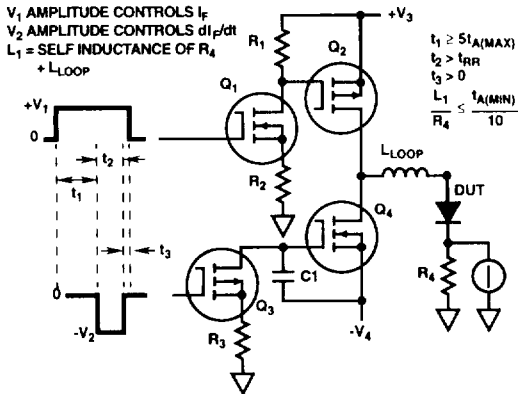

FIGURE 1. t_{RR} TEST CIRCUIT

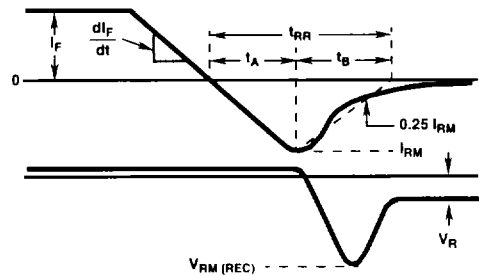

FIGURE 2. DEFINITIONS OF t_{RR} , t_A AND t_B

5
ULTRAFAST
SINGLE DIODES

Typical Performance Curves

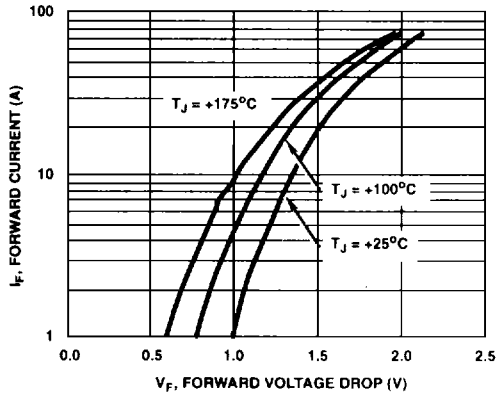

FIGURE 3. FORWARD VOLTAGE vs FORWARD CURRENT CHARACTERISTIC

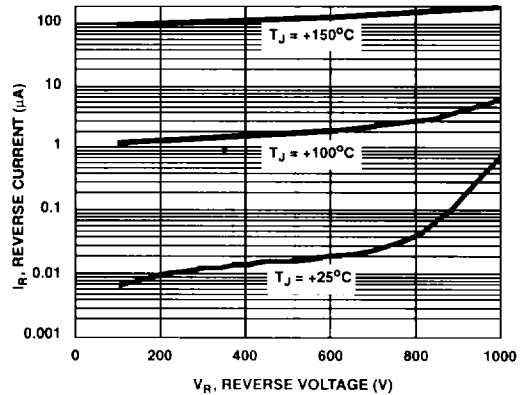

FIGURE 4. REVERSE VOLTAGE vs REVERSE CURRENT CHARACTERISTIC

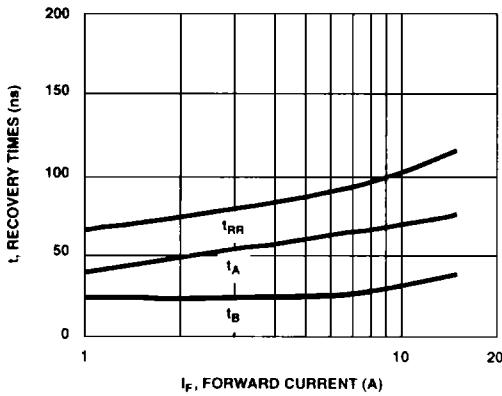

FIGURE 5. TYPICAL t_{RR} , t_A and t_B CURVES vs FORWARD CURRENT

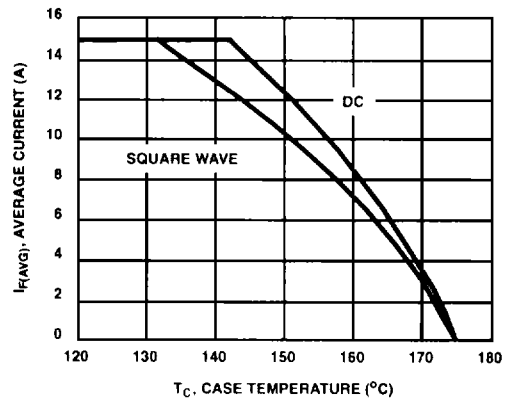

FIGURE 6. TYPICAL CURRENT DERATING CURVE vs CASE TEMPERATURE

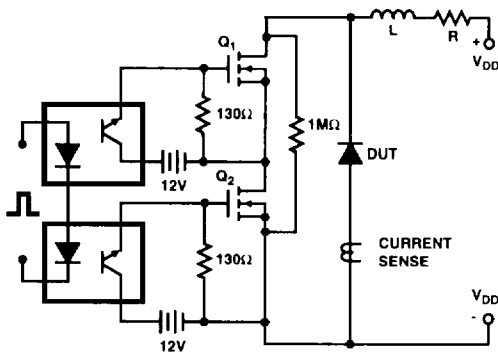

FIGURE 7. AVALANCHE ENERGY TEST CIRCUIT

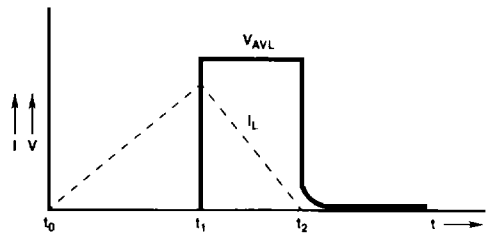

FIGURE 8. CURRENT VOLTAGE WAVEFORM

$$I_{L\text{peak}} = 1\text{A}, L = 40\text{mH}, R < 0.1\Omega, E_{AVL} = (1/2) L I_{L\text{peak}}^2 [V_{AVL}/(V_{AVL} - V_{DD})]$$

Q1 AND Q2 ARE 1000V MOSFETS