

LM2575 1-A Simple Step-Down Switching Voltage Regulator

1 Features

- Adjustable With a Range of 1.23 V to 37 V and $\pm 4\%$ Regulation (Max) Over Line, Load, and Temperature Conditions
- Specified 1-A Output Current
- Wide Input Voltage Range 4.75 V to 40 V
- Uses Readily Available Standard Inductors
- 52-kHz (Typical) Fixed-Frequency Internal Oscillator
- TTL Shutdown Capability With 50- μ A (Typical) Standby Current
- High Efficiency...as High as 88% (Typical)
- Thermal Shutdown and Current-Limit Protection With Cycle-by-Cycle Current Limiting
- For the Full Offering of Voltages (Including Fixed-Output Options) and Packages (Including TO-263), See TL2575 Data Sheet, [SLVS638](#)

2 Applications

- Simple High-Efficiency Step-Down (Buck) Regulator
- Pre-Regulator for Linear Regulators
- On-Card Switching Regulators
- Positive-to-Negative Converter (Buck-Boost)

3 Description

The LM2575 device greatly simplifies the design of switching power supplies by conveniently providing all the active functions needed for a step-down (buck) switching regulator in an integrated circuit. Accepting a wide input voltage range and available in an adjustable output version, the LM2575 has an integrated switch capable of delivering 1 A of load current, with excellent line and load regulation. The device also offers internal frequency compensation, a fixed-frequency oscillator, cycle-by-cycle current limiting, and thermal shutdown. In addition, a manual shutdown is available through an external ON/OFF pin.

The LM2575 represents a superior alternative to popular three-terminal linear regulators. Due to its high efficiency, it significantly reduces the size of the heat sink and, in many cases, no heat sink is required. Optimized for use with standard series of inductors available from several different manufacturers, the LM2575 greatly simplifies the design of switch-mode power supplies by requiring a minimal addition of only four to six external components for operation.

The LM2575 is characterized for operation over the virtual junction temperature range of -40°C to 125°C .

Device Information⁽¹⁾

PART NUMBER	PACKAGE	BODY SIZE (NOM)
LM2575N	PDIP (16)	19.30 mm x 6.35 mm

(1) For all available packages, see the orderable addendum at the end of the data sheet.

Simplified Schematic

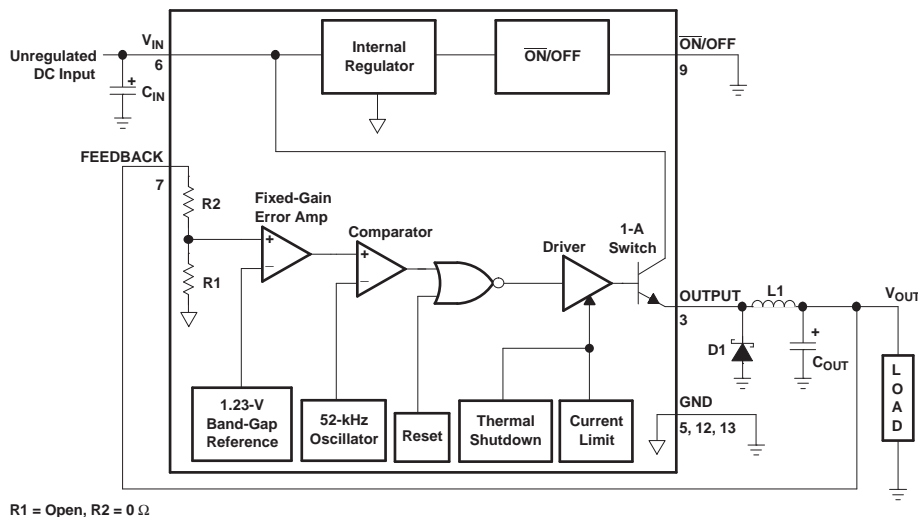

Table of Contents

1 Features	1	7.3 Feature Description	7
2 Applications	1	7.4 Device Functional Modes	8
3 Description	1	8 Application and Implementation	9
4 Revision History	2	8.1 Application Information	9
5 Pin Configuration and Functions	3	8.2 Typical Application	9
6 Specifications	3	9 Power Supply Recommendations	14
6.1 Absolute Maximum Ratings	3	10 Layout	15
6.2 ESD Ratings	4	10.1 Layout Guidelines	15
6.3 Recommended Operating Conditions	4	10.2 Layout Example	15
6.4 Thermal Information	4	11 Device and Documentation Support	16
6.5 Electrical Characteristics	4	11.1 Community Resources	16
6.6 Typical Characteristics	5	11.2 Trademarks	16
7 Detailed Description	7	11.3 Electrostatic Discharge Caution	16
7.1 Overview	7	11.4 Glossary	16
7.2 Functional Block Diagram	7	12 Mechanical, Packaging, and Orderable Information	16

4 Revision History

NOTE: Page numbers for previous revisions may differ from page numbers in the current version.

Changes from Revision E (January 2006) to Revision F

Page

- ESD Rating table, Feature Description section, Device Functional Modes, Application and Implementation section, Power Supply Recommendations section, Layout section, Device and Documentation Support section, and Mechanical, Packaging, and Orderable Information section. **1**

5 Pin Configuration and Functions

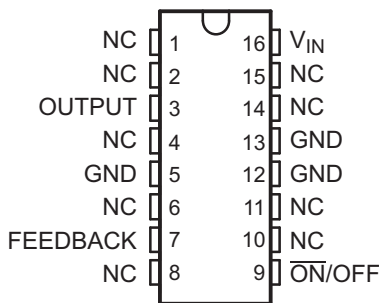
Pin Functions

PIN		I/O	DESCRIPTION
NAME	NO.		
FEEDBACK	7	I	Output voltage sense
GND	5	—	Ground pins, all pins must be connect to ground.
	12		
	13		
$\overline{\text{ON/OFF}}$	9	I	Active low enable
OUTPUT	3	O	Switch output
VIN	16	I	Input voltage supply pin
NC	1	—	Not connected internally, pins can be connected to circuit ground plane for improved thermal performance.
	2		
	4		
	6		
	8		
	10		
	11		
	14		
	15		

6 Specifications

6.1 Absolute Maximum Ratings

over operating free-air temperature range (unless otherwise noted)⁽¹⁾

		MIN	MAX	UNIT
V _{IN}	Supply voltage	−0.3	42	V
	$\overline{\text{ON/OFF}}$ pin input voltage	−0.3	V _{IN}	V
	Output voltage to GND (steady-state)		−1	V
T _J	Maximum junction temperature		150	°C
T _{stg}	Storage temperature	−65	150	°C

- (1) Stresses beyond those listed under *Absolute Maximum Ratings* may cause permanent damage to the device. These are stress ratings only, which do not imply functional operation of the device at these or any other conditions beyond those indicated under *Recommended Operating Conditions*. Exposure to absolute-maximum-rated conditions for extended periods may affect device reliability.

6.2 ESD Ratings

			VALUE	UNIT
$V_{(ESD)}$	Electrostatic discharge	Human body model (HBM), per ANSI/ESDA/JEDEC JS-001, all pins ⁽¹⁾	±2000	V
		Charged-device model (CDM), per JEDEC specification JESD22-C101, all pins ⁽²⁾	±1000	

(1) JEDEC document JEP155 states that 500-V HBM allows safe manufacturing with a standard ESD control process.

(2) JEDEC document JEP157 states that 250-V CDM allows safe manufacturing with a standard ESD control process.

6.3 Recommended Operating Conditions

over operating free-air temperature range (unless otherwise noted)

			MIN	MAX	UNIT
V_{IN}	Supply voltage		4.75	40	V
T_J	Operating virtual junction temperature		−40	125	°C

6.4 Thermal Information

THERMAL METRIC ⁽¹⁾		LM2575	UNIT
		N (PDIP)	
		16 PINS	
$R_{\theta JA}$	Junction-to-ambient thermal resistance	67	°C/W
$R_{\theta JC(top)}$	Junction-to-case (top) thermal resistance	51	°C/W

(1) For more information about traditional and new thermal metrics, see the *Semiconductor and IC Package Thermal Metrics* application report, [SPRA953](#).

6.5 Electrical Characteristics

$I_{LOAD} = 200$ mA, $V_{IN} = 12$ V (unless otherwise noted) (see [Figure 16](#))

PARAMETER	TEST CONDITIONS	T_J	MIN	TYP	MAX	UNIT	
V_{OUT}	Feedback voltage	$V_{OUT} = 5$ V, $I_{LOAD} = 0.2$ A	25°C	1.217	1.23	1.243	V
		8 V $\leq V_{IN} \leq 40$ V, $V_{OUT} = 5$ V, 0.2 A $\leq I_{LOAD} \leq 1$ A	25°C	1.193	1.23	1.267	
		Full range		1.18		1.28	
η	Efficiency	$V_{IN} = 12$ V, $V_{OUT} = 5$ V, $I_{LOAD} = 1$ A	25°C	77%			
I_{IB}	Feedback bias current	$V_{OUT} = 5$ V	25°C	50	100	nA	
		Full range			500		
f_o	Oscillator frequency ⁽¹⁾		25°C	47	52	58	kHz
		Full range		42		63	
V_{SAT}	Saturation voltage	$I_{OUT} = 1$ A ⁽²⁾	25°C	0.9		1.2	V
			Full range			1.4	
	Maximum duty cycle ⁽³⁾		25°C	93%	98%		
I_{CL}	Peak current ^{(1) (2)}		25°C	1.7	2.8	3.6	A
		Full range		1.3		4	
I_L	Output leakage current	$V_{IN} = 40$ ⁽⁴⁾ , Output = 0 V	25°C			2	mA
		$V_{IN} = 40$ ⁽⁴⁾ , Output = −1 V				7.5	
I_Q	Quiescent current ⁽⁴⁾		25°C	5	10	mA	
I_{STBY}	Standby quiescent current	OFF (\overline{ON}/OFF pin = 5 V)	25°C	50	200	µA	

(1) In the event of an output short or an overload condition, self-protection features lower the oscillator frequency to ~18 kHz and the minimum duty cycle from 5% to ~2%. The resulting output voltage drops to ~40% of its nominal value, causing the average power dissipated by the IC to lower.

(2) Output is not connected to diode, inductor, or capacitor. Output is sourcing current.

(3) Feedback is disconnected from output and connected to 0 V.

(4) To force the output transistor off, FEEDBACK is disconnected from output and connected to 12 V.

Electrical Characteristics (continued)

$I_{LOAD} = 200\text{ mA}$, $V_{IN} = 12\text{ V}$ (unless otherwise noted) (see Figure 16)

PARAMETER		TEST CONDITIONS	T_J	MIN	TYP	MAX	UNIT
V_{IH}	$\overline{\text{ON}}/\text{OFF}$ logic input level	OFF ($V_{OUT} = 0\text{ V}$)	25°C	2.2	1.4		V
			Full range	2.4			
V_{IL}	$\overline{\text{ON}}/\text{OFF}$ logic input level	ON ($V_{OUT} = \text{nominal voltage}$)	25°C		1.2	1	V
			Full range			0.8	
I_{IH}	$\overline{\text{ON}}/\text{OFF}$ input current	OFF ($\overline{\text{ON}}/\text{OFF}$ pin = 5 V)	25°C		12	30	μA
I_{IL}		ON ($\overline{\text{ON}}/\text{OFF}$ pin = 0 V)			0	10	

6.6 Typical Characteristics

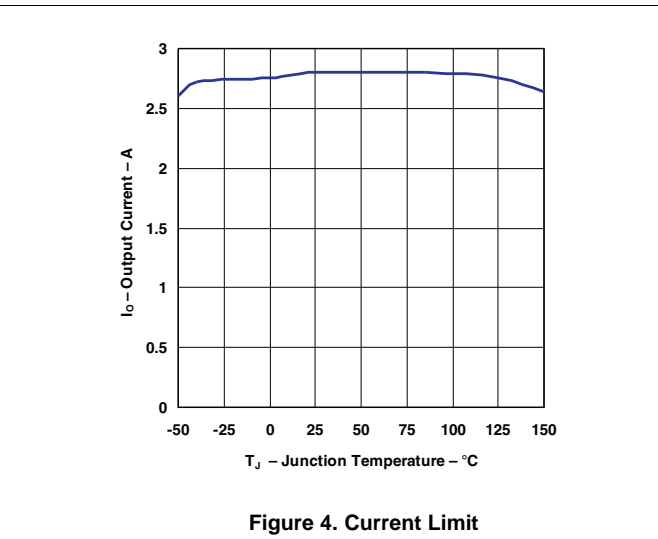
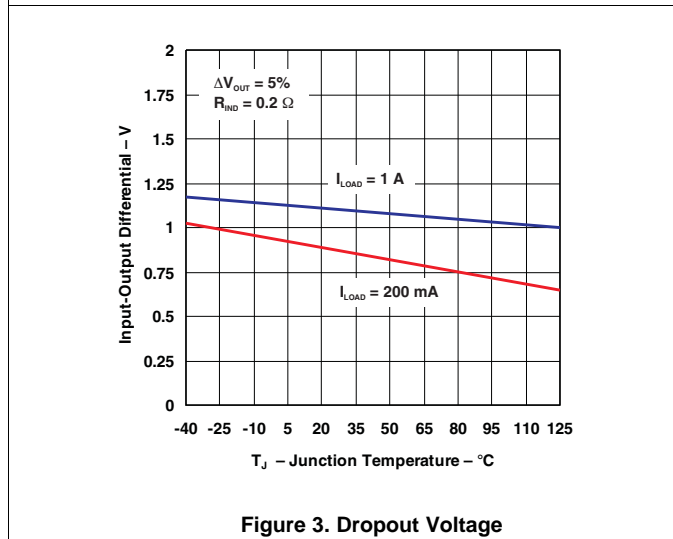
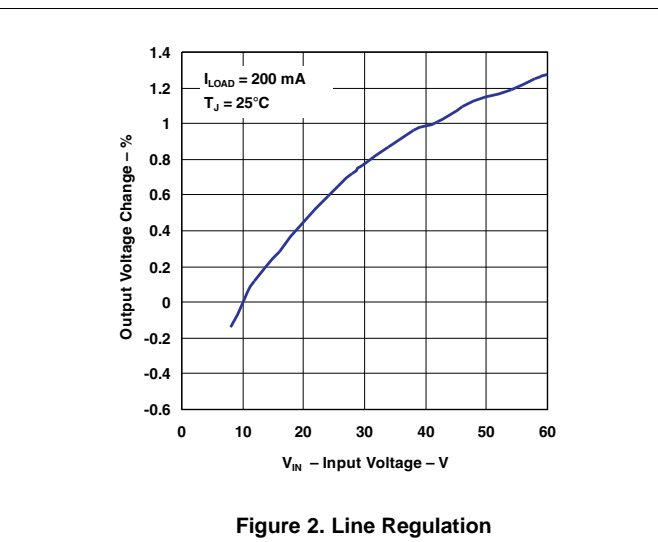
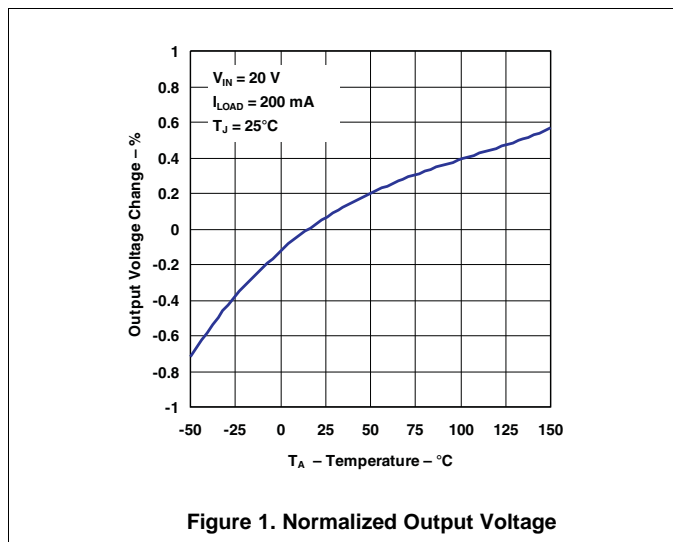

Typical Characteristics (continued)

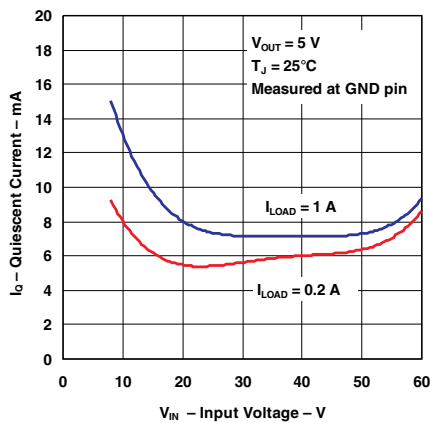

Figure 5. Quiescent Current

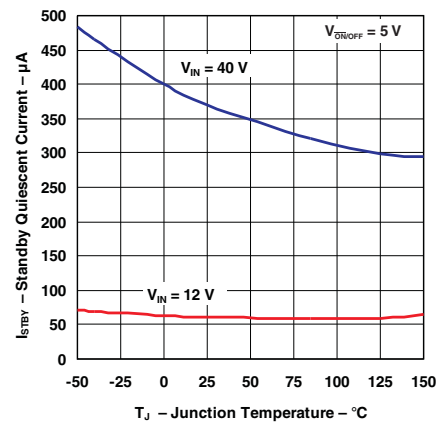

Figure 6. Standby Quiescent Current

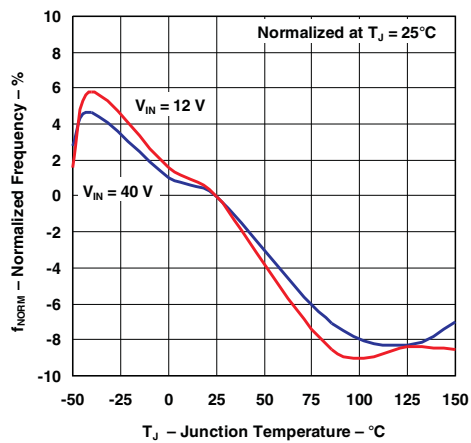

Figure 7. Oscillator Frequency

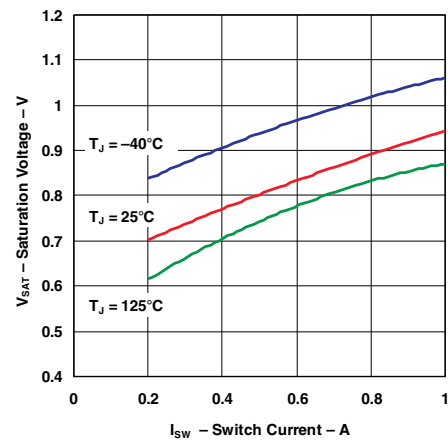

Figure 8. Switch Saturation Voltage

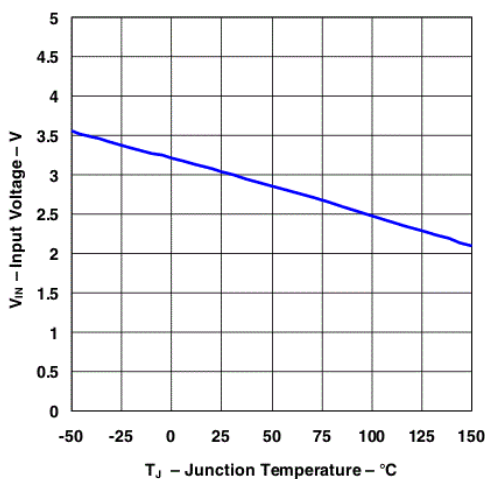

Figure 9. Minimum Operating Voltage

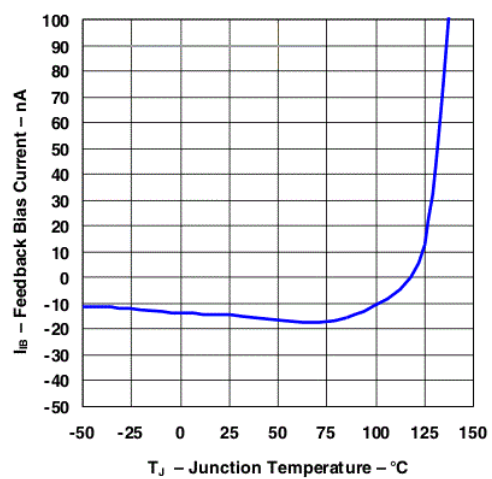

Figure 10. FEEDBACK Current

7 Detailed Description

7.1 Overview

The LM2575 provides all the active functions needed for a step-down (buck) switching regulator in an integrated circuit. The wide input-voltage range is 4.75 V to 40 V. The output voltage is programmable by two external resistors. No external frequency compensation is needed. The integrated switch is capable of delivering 1 A of load current, with excellent line and load regulation. The fixed 52-kHz output has cycle-by-cycle current limiting, and thermal shutdown. In addition, a manual shutdown is available through an external ON/OFF pin.

The LM2575 is characterized for operation over the virtual junction temperature range of -40°C to 125°C .

7.2 Functional Block Diagram

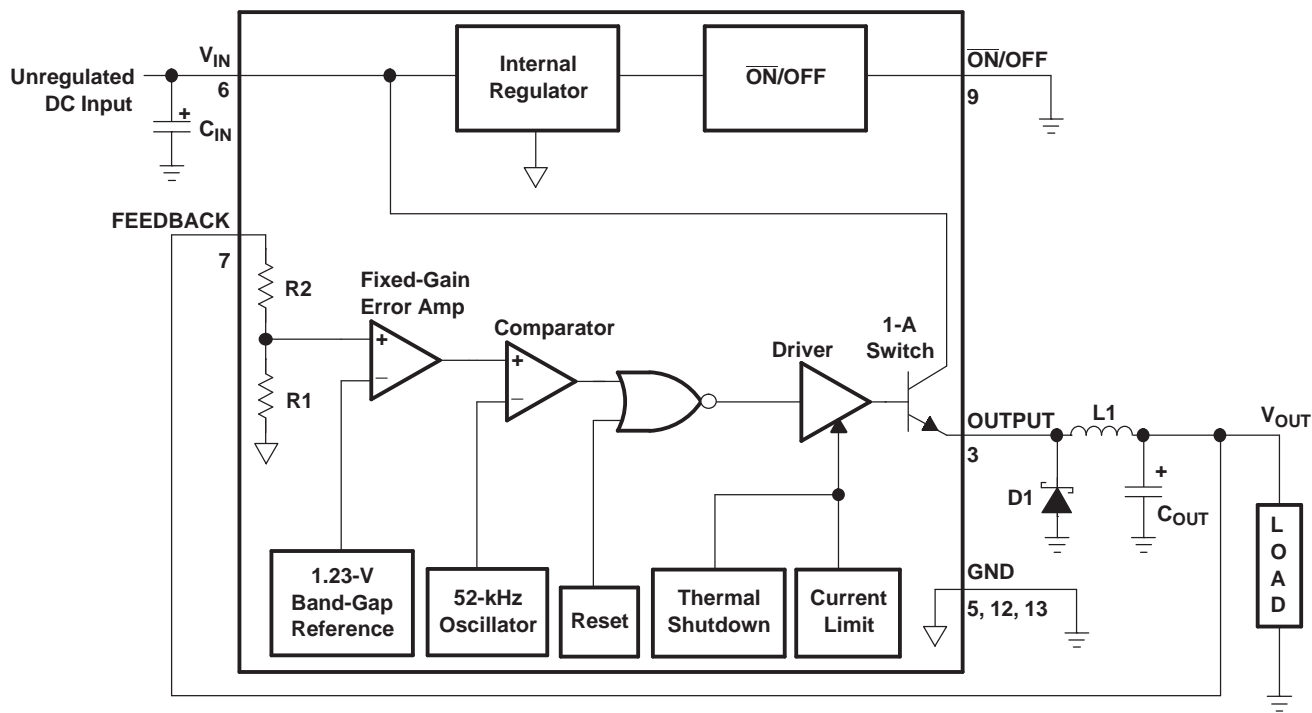

R1 = Open, R2 = 0 Ω

7.3 Feature Description

7.3.1 Feedback Connection

FEEDBACK must be connected between the two programming resistors. Again, both of these resistors must be in close proximity to the regulator, and each must be less than 100 k Ω to minimize noise pickup.

7.3.2 $\overline{\text{ON/OFF}}$ Input

$\overline{\text{ON/OFF}}$ should be grounded or be a low-level TTL voltage (typically < 1.6 V) for normal operation. To shut down the LM2575 device and place in standby mode, a high-level TTL or CMOS voltage should be supplied to this pin. $\overline{\text{ON/OFF}}$ must not be left open and safely can be pulled up to V_{IN} with or without a pullup resistor.

7.3.3 Fault Protection

In the event of an output short or an overload condition, self-protection features lower the oscillator frequency to approximately 18 kHz and the minimum duty cycle from 5% to approximately 2%. The resulting output voltage drops to approximately 40% of its nominal value, causing the average power dissipated by the IC to lower.

7.4 Device Functional Modes

7.4.1 Normal Operation Mode

When a low-level TTL or CMOS voltage is applied to the $\overline{\text{ON}}/\text{OFF}$ pin, the device will provide an output voltage.

7.4.2 Standby Mode

When a high-level TTL or CMOS voltage is applied to the $\overline{\text{ON}}/\text{OFF}$ pin, the device enters standby mode, drawing a typical quiescent current of 50 μA . The internal output switch will be turned off.

8 Application and Implementation

NOTE

Information in the following applications sections is not part of the TI component specification, and TI does not warrant its accuracy or completeness. TI's customers are responsible for determining suitability of components for their purposes. Customers should validate and test their design implementation to confirm system functionality.

8.1 Application Information

The limited component count and internal frequency compensation makes the LM2575 easy use. Output voltage is set by two external resistors.

$$V_{OUT} = V_{REF} \left(1 + \frac{R2}{R1} \right)$$

where

- $V_{REF} = 1.23 \text{ V}$ (1)

8.2 Typical Application

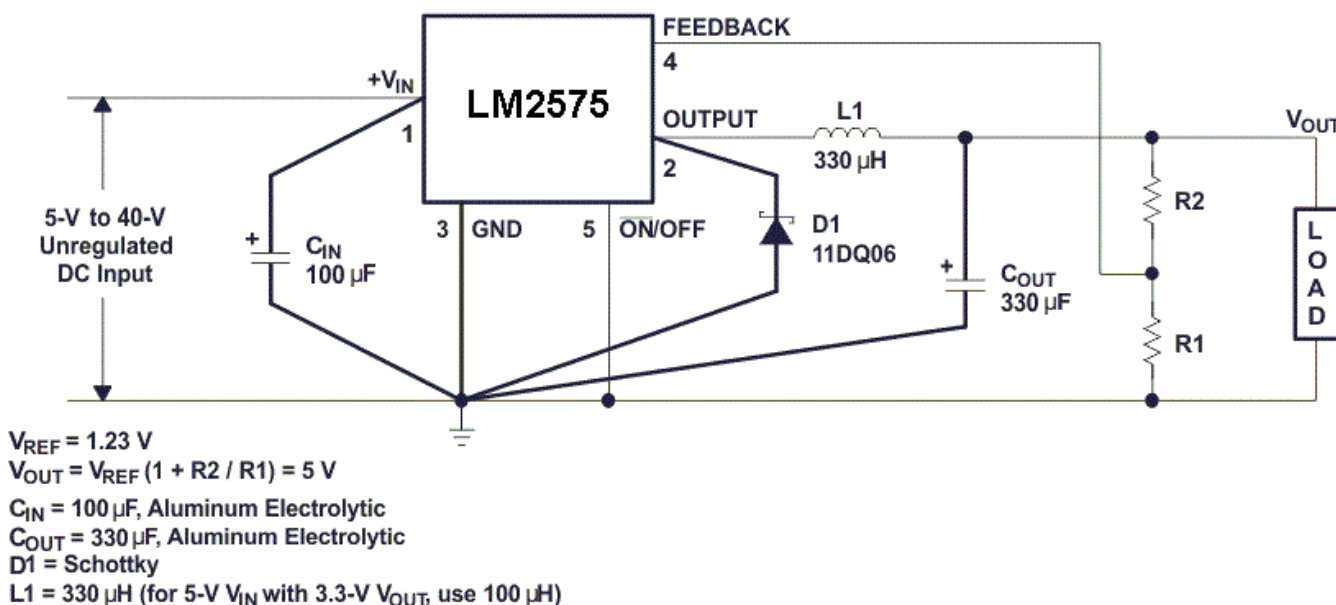

Figure 11. Buck Regulator With User Programmable Output Voltage

8.2.1 Design Requirements

Output voltage is set by R1 and R2. Output voltage must be between V_{REF} and $(V_{IN[\text{minimum}]} - V_{SAT}) \times \text{Duty Cycle} [\text{maximum}]$.

V_{SAT} maximum and duty cycle maximum are specified in the [Electrical Characteristics](#) table.

8.2.2 Detailed Design Procedure

8.2.2.1 Input Capacitor (C_{IN})

For stability concerns, an input bypass capacitor (electrolytic, $C_{IN} \geq 47 \mu\text{F}$) must be located as close as possible to the regulator. For operating temperatures below -25°C , C_{IN} may need to be larger in value. In addition, because most electrolytic capacitors have decreasing capacitances and increasing ESR as temperature drops, adding a ceramic or solid tantalum capacitor in parallel increases the stability in cold temperatures.

Typical Application (continued)

To extend the capacitor operating lifetime, the capacitor RMS ripple current rating should be:

$$I_{C,RMS} > 1.2 \left(\frac{t_{on}}{T} \right) I_{LOAD}, \text{ where:}$$

$$\frac{t_{on}}{T} = \frac{V_{OUT}}{V_{IN}} \text{ \{buck regulator\}, and}$$

$$\frac{t_{on}}{T} = \frac{|V_{OUT}|}{(|V_{OUT}| + V_{IN})} \text{ \{buck-boost regulator\}}$$
(2)

8.2.2.2 Output Capacitor (C_{OUT})

For both loop stability and filtering of ripple voltage, an output capacitor also is required, again in close proximity to the regulator. For best performance, low-ESR aluminum electrolytics are recommended, although standard aluminum electrolytics may be adequate for some applications::

$$\text{Output Ripple Voltage} = (\text{ESR of } C_{OUT}) \times (\text{inductor ripple current})$$
(3)

Output ripple of 50 mV to 150 mV typically can be achieved with capacitor values of 220 μ F to 680 μ F. Larger C_{OUT} can reduce the ripple 20 mV to 50 mV peak-to-peak. To improve further on output ripple, paralleling of standard electrolytic capacitors may be used. Alternatively, higher-grade capacitors such as “high-frequency”, “low-inductance”, or “low-ESR” can be used.

The following should be taken into account when selecting C_{OUT} :

- At cold temperatures, the ESR of the electrolytic capacitors can rise dramatically (typically 3x nominal value at -25°C). Because solid tantalum capacitors have significantly better ESR specifications at cold temperatures, they must be used at operating temperature lower than -25°C . As an alternative, tantalums also can be paralleled to aluminum electrolytics and must contribute 10% to 20% to the total capacitance.
- Low ESR for C_{OUT} is desirable for low output ripple. However, the ESR should be greater than 0.05 Ω to avoid the possibility of regulator instability. Hence, a sole tantalum capacitor used for C_{OUT} is most susceptible to this occurrence.
- The capacitor’s ripple current rating of 52 kHz should be at least 50% higher than the peak-to-peak inductor ripple current.

8.2.2.3 Catch Diode

As with other external components, the catch diode must be placed close to the output to minimize unwanted noise. Schottky diodes have fast switching speeds and low forward voltage drops and, thus, offer the best performance, especially for switching regulators with low output voltages ($V_{OUT} < 5 \text{ V}$). If a high-efficiency, fast-recovery, or ultra-fast-recovery diode is used in place of a Schottky, it must have a soft recovery (versus abrupt turnoff characteristics) to avoid the chance of causing instability and EMI. Standard 50-/60-Hz diodes, such as the 1N4001 or 1N5400 series, are NOT suitable.

8.2.2.4 Inductor

Proper inductor selection is key to the performance-switching power-supply designs. One important factor to consider is whether the regulator will be used in continuous (inductor current flows continuously and never drops to zero) or in discontinuous mode (inductor current goes to zero during the normal switching cycle). Each mode has distinctively different operating characteristics and, therefore, can affect the regulator performance and requirements. In many applications, the continuous mode is the preferred mode of operation, because it offers greater output power with lower peak currents, and also can result in lower output ripple voltage. The advantages of continuous mode of operation come at the expense of a larger inductor required to keep inductor current continuous, especially at low output currents and/or high input voltages.

The LM2575 can operate in either continuous or discontinuous mode. With heavy load currents, the inductor current flows continuously and the regulator operates in continuous mode. Under light load, the inductor fully discharges and the regulator is forced into the discontinuous mode of operation. For light loads (approximately 200 mA or less), this discontinuous mode of operation is perfectly acceptable and may be desirable solely to keep the inductor value and size small. Any buck regulator eventually operates in discontinuous mode when the load current is light enough.

Typical Application (continued)

The type of inductor chosen can have advantages and disadvantages. If high performance or quality is a concern, then more-expensive toroid core inductors are the best choice, as the magnetic flux is contained completely within the core, resulting in less EMI and noise in nearby sensitive circuits. Inexpensive bobbin core inductors, however, generate more EMI as the open core does not confine the flux within the core. Multiple switching regulators located in proximity to each other are particularly susceptible to mutual coupling of magnetic fluxes from each other's open cores. In these situations, closed magnetic structures (such as a toroid, pot core, or E-core) are more appropriate.

Regardless of the type and value of inductor used, the inductor never should carry more than its rated current. Doing so may cause the inductor to saturate, in which case the inductance quickly drops, and the inductor looks like a low-value resistor (from the DC resistance of the windings). As a result, switching current rises dramatically (until limited by the current-by-current limiting feature of the LM2575) and can result in overheating of the inductor and the IC itself.

NOTE

Different types of inductors have different saturation characteristics.

8.2.2.5 Output Voltage Ripple and Transients

As with any switching power supply, the output of the LM2575 has a sawtooth-ripple voltage at the switching frequency. Typically about 1% of the output voltage, this ripple is due mainly to the inductor sawtooth-ripple current and the ESR of the output capacitor (see note on C_{OUT}). Furthermore, the output also may contain small voltage spikes at the peaks of the sawtooth waveform. This is due to the fast switching of the output switch and the parasitic inductance of C_{OUT} . These voltage spikes can be minimized through the use of low-inductance capacitors.

There are several ways to reduce the output ripple voltage: a larger inductor, a larger C_{OUT} , or both. Another method is to use a small LC filter (20 μ H and 100 μ F) at the output. This filter can reduce the output ripple voltage by a factor of 10 (see [Figure 16](#)).

8.2.2.6 Feedback Connection

FEEDBACK must be connected between the two programming resistors. Again, both of these resistors should be in close proximity to the regulator, and each should be less than 100 k Ω to minimize noise pickup.

8.2.2.7 $\overline{ON/OFF}$ Input

$\overline{ON/OFF}$ should be grounded or be a low-level TTL voltage (typically <1.6 V) for normal operation. To shut down the LM2575 and put it in standby mode, a high-level TTL or CMOS voltage must be supplied to this pin. $\overline{ON/OFF}$ must not be left open and safely can be pulled up to V_{IN} with or without a pullup resistor.

8.2.2.8 Grounding

The power and ground connections of the LM2575 must be low-impedance to help maintain output stability. With the 16-pin package, all the ground pins (including signal and power grounds) must be soldered directly to wide PCB copper traces to ensure low-inductance connections and good thermal dissipation.

8.2.2.9 Reverse Current Considerations

There is an internal diode from the output to V_{IN} . Therefore, the device does not protect against reverse current and take care to limit current in this scenario.

8.2.2.10 Buck Regulator Design Procedure

PROCEDURE	EXAMPLE
Known: $V_{OUT(Nom)}$ $V_{IN(Max)}$ = Maximum input voltage $I_{LOAD(Max)}$ = Maximum load current	Known: $V_{OUT} = 10$ V $V_{IN(Max)} = 25$ V $I_{LOAD(Max)} = 1$ A

Typical Application (continued)

PROCEDURE	EXAMPLE
<p>1. Programming Output Voltage (Selecting R1 and R2)</p> <p>V_{OUT} is defined by:</p> $V_{OUT} = V_{REF} \left(1 + \frac{R2}{R1} \right) \quad \text{where } V_{REF} = 1.23 \text{ V}$ <p>Choose a value for R1 between 1 kΩ and 5 kΩ (use 1% metal-film resistors for best temperature coefficient and stability over time).</p> $R2 = R1 \left(\frac{V_{OUT}}{V_{REF}} - 1 \right)$	<p>1. Programming Output Voltage (Selecting R1 and R2)</p> <p>Select R1 = 1 kΩ R2 = 1 (10 / 1.23 – 1) = 7.13 kΩ Select R2 = 7.15 kΩ (closest 1% value)</p>
<p>2. Inductor Selection (L1)</p> <p>A. Calculate the "set" volts-second (E x T) across L1: $E \times T = (V_{IN} - V_{OUT}) \times t_{on}$ $E \times T = (V_{IN} - V_{OUT}) \times (V_{OUT} / V_{IN}) \times \{1000 / f_{osc}(\text{in kHz})\} [V \times \mu s]$</p> <p>NOTE: Along with I_{LOAD}, the "set" volts-second (E x T) constant establishes the minimum energy storage requirement for the inductor.</p> <p>B. Using Figure 12, select the appropriate inductor code based on the intersection of E x T value and $I_{LOAD(Max)}$.</p> <p>C. The inductor chosen should be rated for operation at 52-kHz and have a current rating of at least $1.15 \times I_{LOAD(Max)}$ to allow for the ripple current. The actual peak current in L1 (in normal operation) can be calculated as follows: $I_{L1(pk)} = I_{LOAD(Max)} + (V_{IN} - V_{OUT}) \times t_{on} / 2L1$ Where $t_{on} = V_{OUT} / V_{IN} \times (1 / f_{osc})$</p>	<p>2. Inductor Selection (L1)</p> <p>A. Calculate the "set" volts-second (E x T) across L1: $E \times T = (25 - 10) \times (10 / 25) \times (1000 / 52) [V \times \mu s]$ $E \times T = 115 \text{ V} \times \mu s$</p> <p>B. Using Figure 12, the intersection of 115 V • μs and 1 A corresponds to an inductor code of H470.</p> <p>C. H470 → L1 = 470 μH Choose from: 34048 (Schott) PE-53118 (Pulse Engineering) RL1961 (Renco)</p>
<p>3. Output Capacitor Selection (C_{OUT})</p> <p>A. The LM2575 control loop has a two-pole two-zero frequency response. The dominant pole-zero pair is established by C_{OUT} and L1. To meet stability requirements, C_{OUT} must meet the following requirement: $C_{OUT} \geq 7758 \frac{V_{IN(Max)}}{V_{OUT} \cdot L1(\mu H)} (\mu F)$</p> <p>However, C_{OUT} may need to be several times larger than the calculated value above in order to achieve an acceptable output ripple voltage of about 0.01 x V_{OUT}.</p> <p>B. C_{OUT} should have a voltage rating of at least 1.5 x V_{OUT}. But if a low output ripple voltage is desired, choose capacitors with a higher voltage ratings than the minimum required due to their typically lower ESRs.</p>	<p>3. Output Capacitor Selection (C_{OUT})</p> <p>A. $C_{OUT} \geq 7785 \times 25 / (10 \times 470) [\mu F]$ $C_{OUT} \geq 41.4 \mu F$ To obtain an acceptable output voltage ripple → $C_{OUT} = 220 \mu F$ electrolytic</p>
<p>4. Catch Diode Selection (D1) (see Table 1)</p> <p>A. In normal operation, the catch diode requires a current rating of at least $1.2 \times I_{LOAD(Max)}$. For the most robust design, D1 should be rated for a current equal to the LM2575 maximum switch peak current; this represents the worst-case scenario of a continuous short at V_{OUT}.</p> <p>B. The diode requires a reverse voltage rating of at least $1.25 \times V_{IN(Max)}$.</p>	<p>4. Catch Diode Selection (D1) (see Table 1)</p> <p>A. Pick a diode with a 3-A rating.</p> <p>B. Pick a 40-V rated Schottky diode (1N5822, MBR340, 31QD04, or SR304) or 100-V rated Fast Recovery diode (31DF1, MURD310, or HER302)</p>
<p>5. Input Capacitor (C_{IN})</p> <p>An aluminum electrolytic or tantalum capacitor is needed for input bypassing. Locate C_{IN} as close to V_{IN} and GND pins as possible.</p>	<p>5. Input Capacitor (C_{IN})</p> <p>C_{IN} = 100 μF, 35 V, aluminum electrolytic</p>

Table 1. Diode Selection Guide

V _R	SCHOTTKY		FAST RECOVERY	
	1A	3A	1A	3A
20 V	1N5817 MBR120P SR102	1N5820 MBR320 SR302	The following diodes are all rated to 100 V: 11DF1 MUR110 HER102	The following diodes are all rated to 100 V: 31DF1 MURD310 HER302
30 V	1N5818 MBR130P 11DQ03 SR103	1N5821 MBR330 31DQ03 SR303		
40 V	1N5819 MBR140P 11DQ04 SR104	1N5822 MBR340 31DQ04 SR304		
50 V	MBR150 11DQ05 SR105	MBR350 31DQ05 SR305		
60 V	MBR160 11DQ06 SR106	MBR360 31DQ06 SR306		

8.2.2.11 Inductor Selection Guide

Figure 12 shows the inductor value selection guide for continuous-mode operation

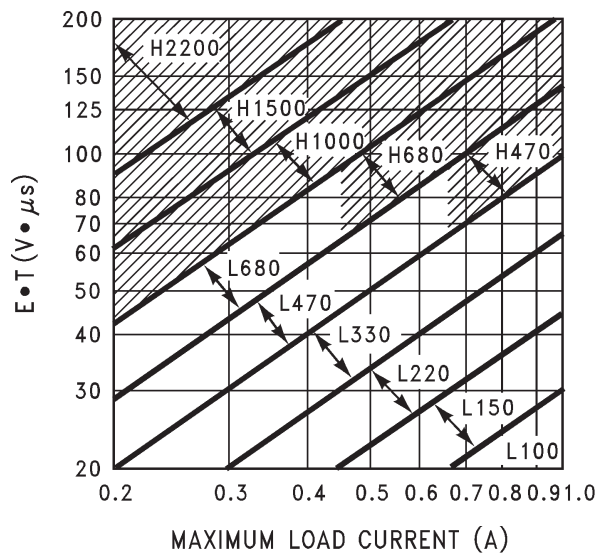
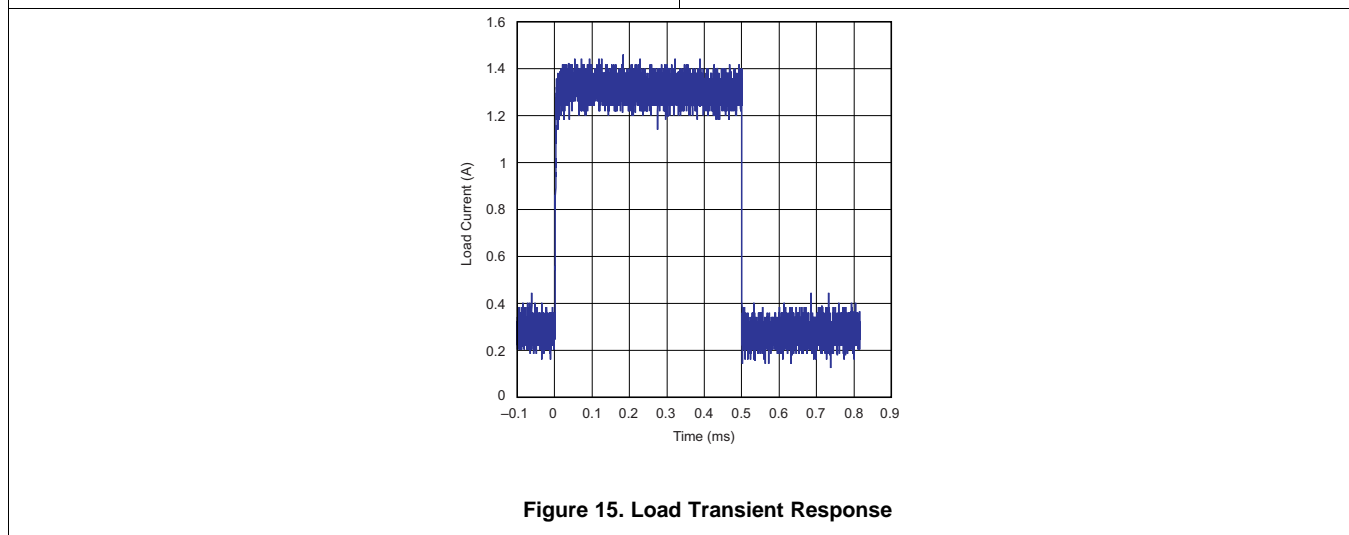
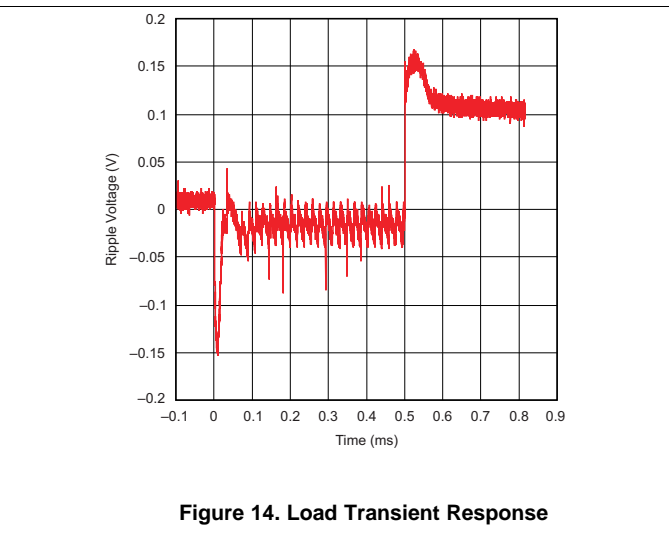
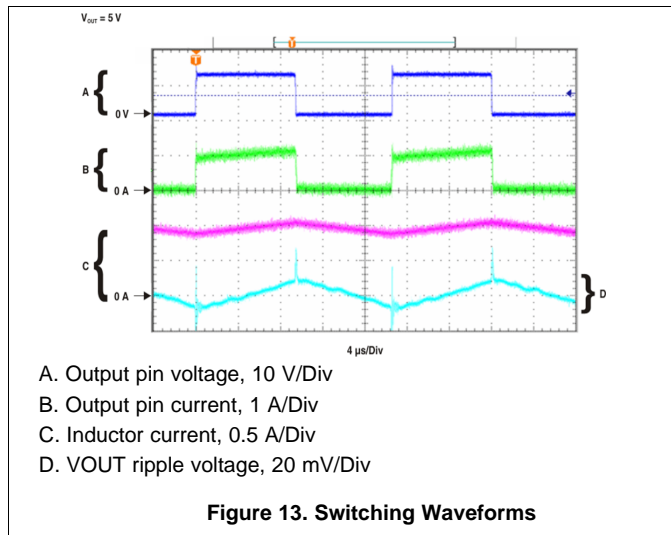

Figure 12. LM2575 Inductor Selection

8.2.3 Application Curves



9 Power Supply Recommendations

This device operates with a power supply range of 4.75 V to 40 V. A 100-μF decoupling capacitor is recommended on the input to filter noise.

10 Layout

10.1 Layout Guidelines

With any switching regulator, circuit layout plays an important role in circuit performance. Wiring and parasitic inductances, as well as stray capacitances, are subjected to rapidly switching currents, which can result in unwanted voltage transients. To minimize inductance and ground loops, the length of the leads indicated by heavy lines (see Figure 16) must be minimized. Optimal results can be achieved by single-point grounding or by ground-plane construction. For the same reasons, the two programming resistors used in the adjustable version must be located as close as possible to the regulator to keep the sensitive feedback wiring short.

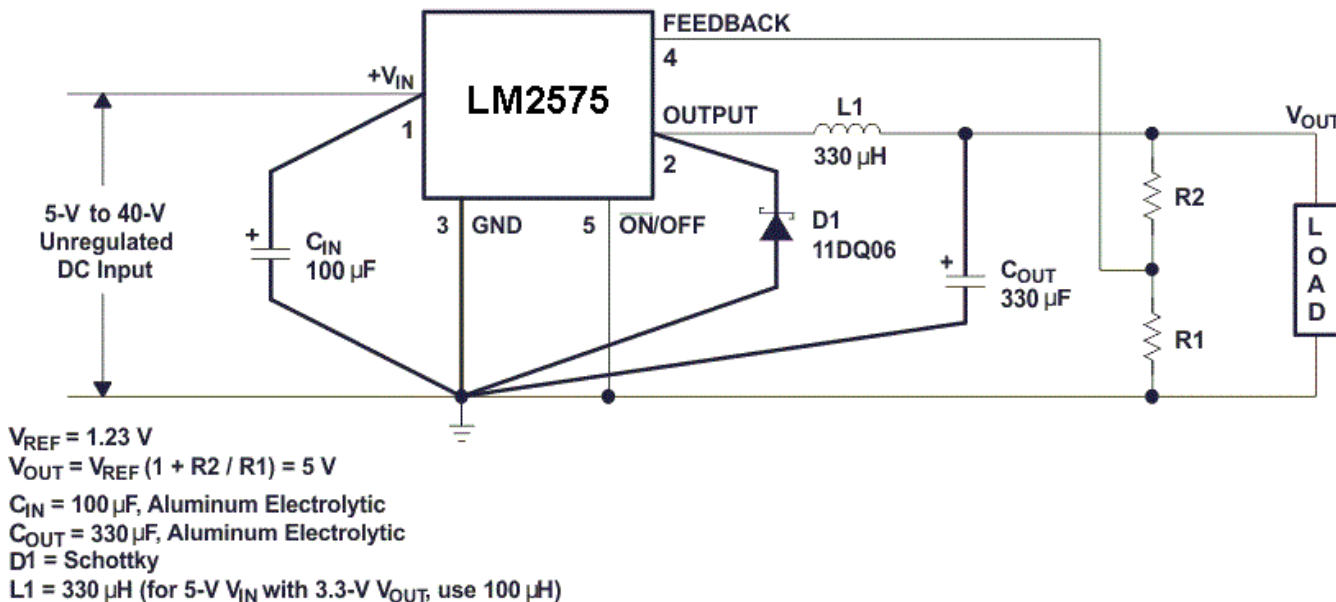

Figure 16. Test Circuit and Layout Guidelines

10.2 Layout Example

The large ground copper area helps heat transfer especially when many vias to ground plane are used.

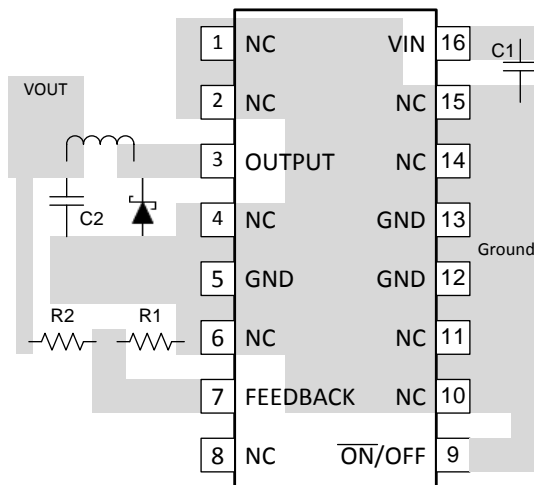

Figure 17. Layout Diagram

11 Device and Documentation Support

11.1 Community Resources

The following links connect to TI community resources. Linked contents are provided "AS IS" by the respective contributors. They do not constitute TI specifications and do not necessarily reflect TI's views; see TI's [Terms of Use](#).

TI E2E™ Online Community *TI's Engineer-to-Engineer (E2E) Community*. Created to foster collaboration among engineers. At e2e.ti.com, you can ask questions, share knowledge, explore ideas and help solve problems with fellow engineers.

Design Support *TI's Design Support* Quickly find helpful E2E forums along with design support tools and contact information for technical support.

11.2 Trademarks

E2E is a trademark of Texas Instruments.
All other trademarks are the property of their respective owners.

11.3 Electrostatic Discharge Caution



These devices have limited built-in ESD protection. The leads should be shorted together or the device placed in conductive foam during storage or handling to prevent electrostatic damage to the MOS gates.

11.4 Glossary

[SLYZ022](#) — *TI Glossary*.

This glossary lists and explains terms, acronyms, and definitions.

12 Mechanical, Packaging, and Orderable Information

The following pages include mechanical, packaging, and orderable information. This information is the most current data available for the designated devices. This data is subject to change without notice and revision of this document. For browser-based versions of this data sheet, refer to the left-hand navigation.

PACKAGING INFORMATION

Orderable Device	Status (1)	Package Type	Package Drawing	Pins	Package Qty	Eco Plan (2)	Lead/Ball Finish (6)	MSL Peak Temp (3)	Op Temp (°C)	Device Marking (4/5)	Samples
LM2575IN	ACTIVE	PDIP	N	16	25	Pb-Free (RoHS)	NIPDAU	N / A for Pkg Type	-40 to 125	LM2575IN	Samples

(1) The marketing status values are defined as follows:

ACTIVE: Product device recommended for new designs.

LIFEBUY: TI has announced that the device will be discontinued, and a lifetime-buy period is in effect.

NRND: Not recommended for new designs. Device is in production to support existing customers, but TI does not recommend using this part in a new design.

PREVIEW: Device has been announced but is not in production. Samples may or may not be available.

OBSOLETE: TI has discontinued the production of the device.

(2) **RoHS:** TI defines "RoHS" to mean semiconductor products that are compliant with the current EU RoHS requirements for all 10 RoHS substances, including the requirement that RoHS substance do not exceed 0.1% by weight in homogeneous materials. Where designed to be soldered at high temperatures, "RoHS" products are suitable for use in specified lead-free processes. TI may reference these types of products as "Pb-Free".

RoHS Exempt: TI defines "RoHS Exempt" to mean products that contain lead but are compliant with EU RoHS pursuant to a specific EU RoHS exemption.

Green: TI defines "Green" to mean the content of Chlorine (Cl) and Bromine (Br) based flame retardants meet JS709B low halogen requirements of <=1000ppm threshold. Antimony trioxide based flame retardants must also meet the <=1000ppm threshold requirement.

(3) MSL, Peak Temp. - The Moisture Sensitivity Level rating according to the JEDEC industry standard classifications, and peak solder temperature.

(4) There may be additional marking, which relates to the logo, the lot trace code information, or the environmental category on the device.

(5) Multiple Device Markings will be inside parentheses. Only one Device Marking contained in parentheses and separated by a "~" will appear on a device. If a line is indented then it is a continuation of the previous line and the two combined represent the entire Device Marking for that device.

(6) Lead/Ball Finish - Orderable Devices may have multiple material finish options. Finish options are separated by a vertical ruled line. Lead/Ball Finish values may wrap to two lines if the finish value exceeds the maximum column width.

Important Information and Disclaimer:The information provided on this page represents TI's knowledge and belief as of the date that it is provided. TI bases its knowledge and belief on information provided by third parties, and makes no representation or warranty as to the accuracy of such information. Efforts are underway to better integrate information from third parties. TI has taken and continues to take reasonable steps to provide representative and accurate information but may not have conducted destructive testing or chemical analysis on incoming materials and chemicals. TI and TI suppliers consider certain information to be proprietary, and thus CAS numbers and other limited information may not be available for release.

In no event shall TI's liability arising out of such information exceed the total purchase price of the TI part(s) at issue in this document sold by TI to Customer on an annual basis.

N (R-PDIP-T**)

PLASTIC DUAL-IN-LINE PACKAGE

16 PINS SHOWN



- NOTES:
- A. All linear dimensions are in inches (millimeters).
 - B. This drawing is subject to change without notice.
 - Falls within JEDEC MS-001, except 18 and 20 pin minimum body length (Dim A).
 - The 20 pin end lead shoulder width is a vendor option, either half or full width.

IMPORTANT NOTICE AND DISCLAIMER

TI PROVIDES TECHNICAL AND RELIABILITY DATA (INCLUDING DATASHEETS), DESIGN RESOURCES (INCLUDING REFERENCE DESIGNS), APPLICATION OR OTHER DESIGN ADVICE, WEB TOOLS, SAFETY INFORMATION, AND OTHER RESOURCES "AS IS" AND WITH ALL FAULTS, AND DISCLAIMS ALL WARRANTIES, EXPRESS AND IMPLIED, INCLUDING WITHOUT LIMITATION ANY IMPLIED WARRANTIES OF MERCHANTABILITY, FITNESS FOR A PARTICULAR PURPOSE OR NON-INFRINGEMENT OF THIRD PARTY INTELLECTUAL PROPERTY RIGHTS.

These resources are intended for skilled developers designing with TI products. You are solely responsible for (1) selecting the appropriate TI products for your application, (2) designing, validating and testing your application, and (3) ensuring your application meets applicable standards, and any other safety, security, or other requirements. These resources are subject to change without notice. TI grants you permission to use these resources only for development of an application that uses the TI products described in the resource. Other reproduction and display of these resources is prohibited. No license is granted to any other TI intellectual property right or to any third party intellectual property right. TI disclaims responsibility for, and you will fully indemnify TI and its representatives against, any claims, damages, costs, losses, and liabilities arising out of your use of these resources.

TI's products are provided subject to TI's Terms of Sale (www.ti.com/legal/termsofsale.html) or other applicable terms available either on ti.com or provided in conjunction with such TI products. TI's provision of these resources does not expand or otherwise alter TI's applicable warranties or warranty disclaimers for TI products.

Mailing Address: Texas Instruments, Post Office Box 655303, Dallas, Texas 75265
Copyright © 2020, Texas Instruments Incorporated