

High Efficiency, Synchronous, Step-down (Buck) Controllers

FEATURES

- Operation to 36V Input Voltage
- Fixed Frequency Average Current Mode Control
- Standby Mode for Improved Efficiency at Light Load
- Drives External N-Channel MOSFETs for Highest Efficiency
- Sleep Mode Current < 50mA
- Complementary 1 Amp Outputs with Regulated Gate Drive Voltage
- LDO (Low Drop Out) Virtual 100% Duty Cycle Operation
- Non-Overlapping Gate Drives

DESCRIPTION

Not Recommended for New Designs.

The UC3874 family of synchronous step-down (Buck) regulators provides high efficiency power conversion from an input voltage range of 4.5 to 36 volts. The UC3874 is tailored for battery powered applications such as laptop computers, consumer products, communications systems, and aerospace which demand high performance and long battery life. The synchronous regulator replaces the catch diode in the standard buck regulator with a low $R_{ds(on)}$ N-channel MOSFET switch allowing for significant efficiency improvements. The high side N-channel MOSFET switch is driven out of phase from the low side N-channel MOSFET switch by an on-chip bootstrap circuit which requires only a single external capacitor to develop the regulated gate drive. Fixed frequency, average current mode control provides the regulator with inherent slope compensation, tight regulation of the output voltage, and superior load and line transient response. Switching frequencies up to 300kHz are possible.

Light load efficiency is improved by a fully programmable standby mode, in which the quiescent current consumption of the controller is significantly reduced. The reduction is achieved by disabling the MOSFET driver outputs and the internal oscillator when the controller has sensed that the the output load current has dropped a user programmable amount from full load.

BLOCK DIAGRAM

(continued)

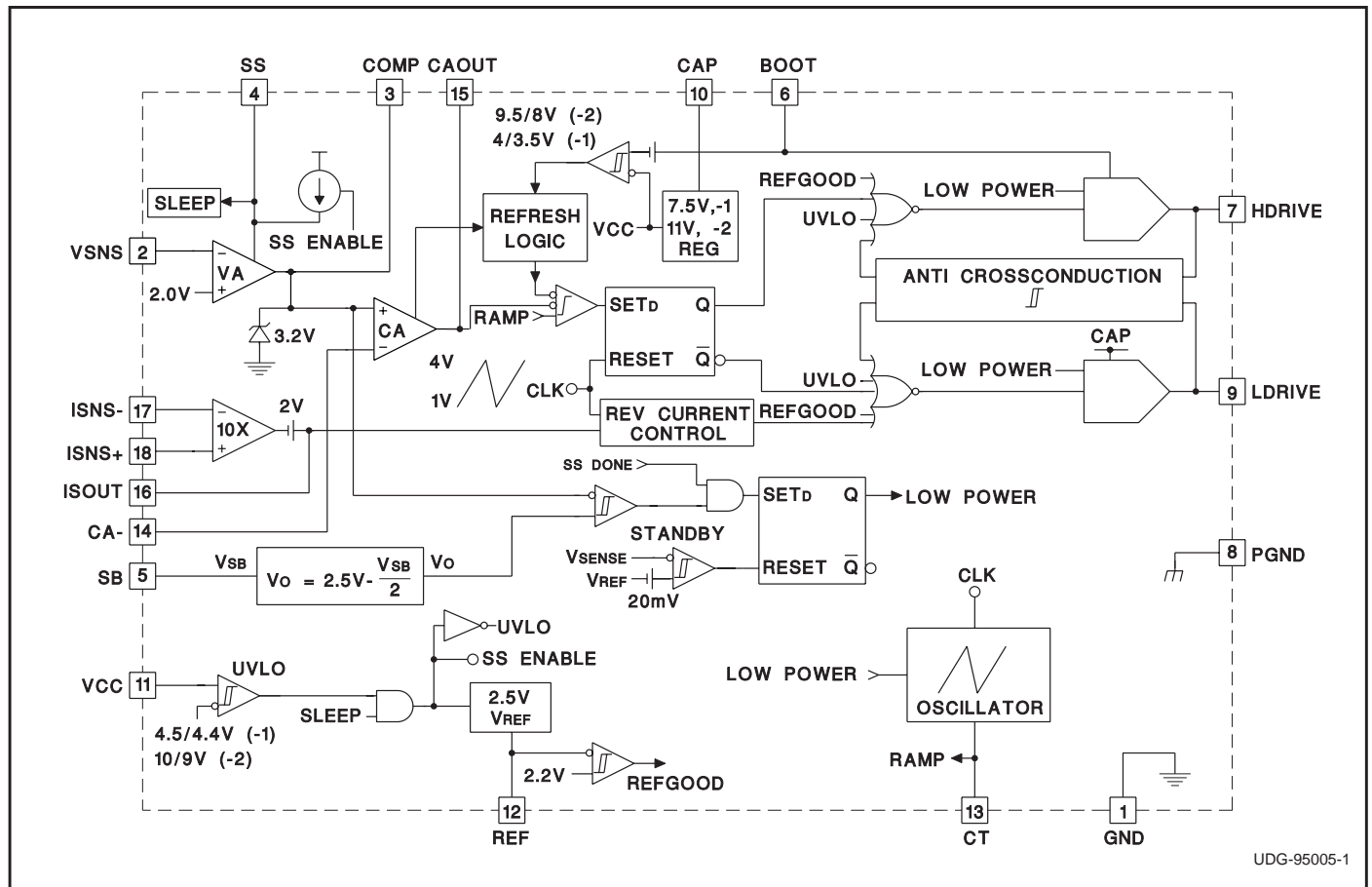

UDG-95005-1

UC1874-1,-2
UC2874-1,-2
UC3874-1,-2

During standby operation, the output capacitor supplies all of the load current requirements. Normal operation returns when the output voltage has drooped by 1%. Reverse current in the inductor is prevented by on-chip circuitry providing additional efficiency improvements. Virtual 100% duty cycle operation is easily attained by the controller even though a bootstrapped high side drive technique is employed.

A low power sleep mode can be invoked through the SS pin. Quiescent supply current in sleep mode is typically less than 50mA. Two UVLO options are available. The

UC3874-1 is designed for logic level MOSFETs and has UVLO turn-on and turn-off thresholds of 4.5V and 4.4V respectively. The UC3874-2 is designed for standard power MOSFETs and has UVLO turn-on and turn-off thresholds of 10V and 9V respectively. A precision 2.5V reference can supply 20mA to external circuitry. An error amplifier with soft start, high bandwidth current amplifier, and a synchronizable oscillator are additional features.

Available packages include 18-pin plastic and ceramic DIP (N, J), 18-pin SOIC (DW), and 20-pin plastic and ceramic leadless chip carriers (Q, L).

ABSOLUTE MAXIMUM RATINGS

Supply Voltage (VCC)	36V
Boost Voltage (BOOT)	50V
OUTPUT Drivers (HDRIVE, LDRIVE) Currents	
(continuous)	±0.25A
(peak)	±1A
VREF Current	Internally Limited
Inputs (VSNS, SS, COMP, CT)	-0.3 to 10V
Inputs (ISNS+, ISNS-)	-0.3 to 20V
Outputs (CAOUT)	-0.3 to 10V
Soft start Sinking Current	1.5mA
Storage Temperature	-65°C to +150°C
Junction Temperature	-65°C to +150°C
Lead Temperature (Soldering, 10 sec.)	+300°C

All currents are positive into, negative out of the specified terminal. All voltages are referenced to GND. Consult Packaging Section of Databook for thermal limitations and considerations of packages.

CONNECTION DIAGRAMS

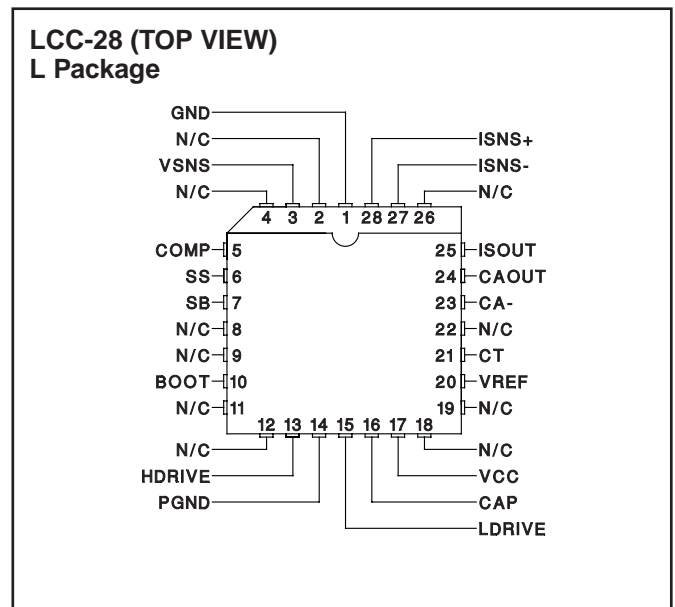
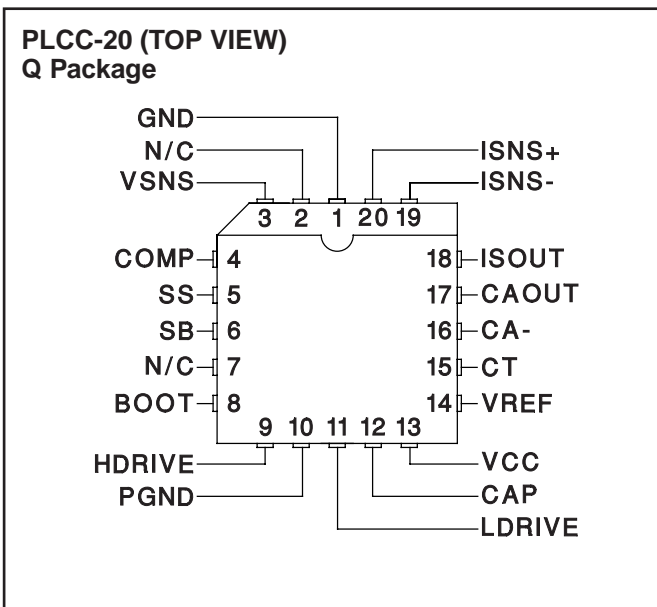
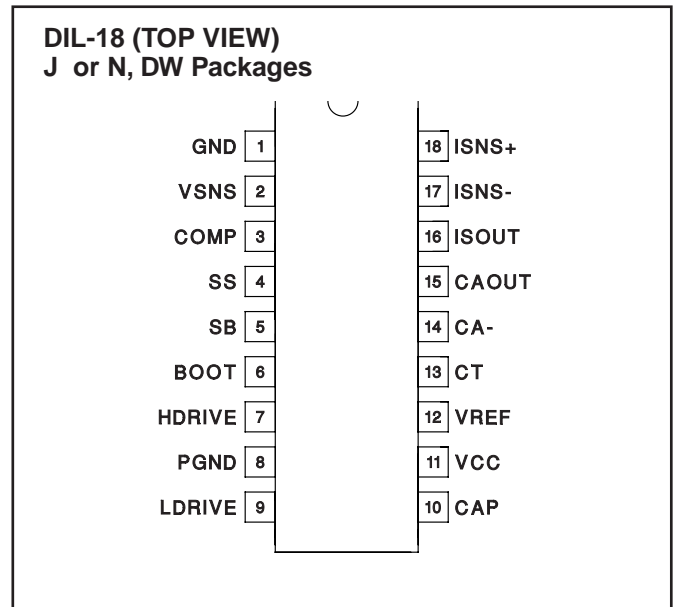

ELECTRICAL CHARACTERISTICS: Unless otherwise stated these specifications apply for $T_A = -55^{\circ}\text{C}$ to $+125^{\circ}\text{C}$ for UC1874; $T_A = -25^{\circ}\text{C}$ to $+85^{\circ}\text{C}$ for UC2874; 0°C to $+70^{\circ}\text{C}$ for UC3874; $V_{CC} = 12\text{V}$, $C_t = 680\text{pF}$, $C_{CAP} = 1\mu\text{F}$; $C_{BOOT} = 0.1\mu\text{F}$; $T_A = T_J$.

PARAMETER	TEST CONDITIONS	MIN	TYP	MAX	UNITS
Overall Section					
Supply Current, Sleep	SOFTSTART = 0V; $T_A = 25^{\circ}\text{C}$		30	75	μA
Supply Current, Operating			8.5	12	mA
Supply Current, Standby	UC2874-1, -2, UC3874-1, -2		2.5	3.5	mA
Supply Current, Standby	UC1874-1, -2			5.5	mA
Vcc Turn-on Threshold	UCX874-2		10	10.5	V
	UCX874-1		4.5	4.8	V
Vcc Turn-off Threshold	UCX874-2	8.5	9		V
	UCX874-1	4.1	4.4		V
Voltage Amplifier Section					
Input Voltage	$T_A = 25^{\circ}\text{C}$	1.97	2	2.03	V
VSNS Bias Current		-500	25	500	nA
Transconductance	$I_{COMP} = +10\mu\text{A}$ to $-10\mu\text{A}$, UC3874 -1, -2; UC2874-1, -2	400	675	1000	μMho
Transconductance	$I_{COMP} = +5\mu\text{A}$ to $-5\mu\text{A}$, UC1874-1,-2	250	675	1250	μMho
VOUT High		2.9	3.1	3.25	V
VOUT Low	SB = VREF			1.85	V
Output Source Current	$V_{OUT} = 1\text{V}$; UC3874-1,-2; UC2874-1,-2	10	35		μA
	$V_{OUT} = 1\text{V}$; UC1874 -1,-2	5	35		μA
Current Amplifier Section					
Input Offset Voltage	$V_{COMP} = 2.5\text{V}$	-6	0	6	mV
Input Bias Current (SENSE)	$V_{CM} = 2.5\text{V}$	-500		500	nA
Open Loop Gain	$V_{CM} = 2.5\text{V}$, $V_{OUT} = 1\text{V}$ to 3.5V	80	110		dB
VOUT High	$R_{CAOUT} = 100\text{k}$ to GND, $T_A = 25^{\circ}\text{C}$	3.6	3.7		V
VOUT Low	$R_{CAOUT} = 100\text{k}$ to VREF, $T_A = 25^{\circ}\text{C}$		0.7	0.86	V
Output Source Current	$V_{OUT} = 0\text{V}$, $T_A = 25^{\circ}\text{C}$	80	100	120	μA
Common Mode REJ Ratio	$V_{CM} = 2\text{V}$ to 3V	70	90		dB
Gain Bandwidth Product	$F_{IN} = 100\text{kHz}$, 10mV p-p	2	3.5		MHz
Reference Section					
Output Voltage	$I_{REF} = 0\text{mA}$, $T_A = 25^{\circ}\text{C}$	2.462	2.5	2.538	V
	$I_{REF} = 0\text{mA}$	2.437	2.5	2.563	V
Load Regulation	$I_{REF} = 0\text{mA}$ to 5mA		2	± 15	mV
Line Regulation	$V_{CC} = 12\text{V}$ to 24V		2	± 15	mV
Short Circuit Current	$V_{REF} = 0\text{V}$	10	20	25	mA
Oscillator Section					
Initial Accuracy	$T_A = 25^{\circ}\text{C}$	85	100	115	kHz
Voltage Stability	$V_{CC} = 12\text{V}$ to 18V		1	1.5	%
Total Variation	Line, Temperature	80		120	kHz
Ramp Amplitude (p-p)	$T_A = 25^{\circ}\text{C}$	2.48	2.7	2.85	V
Ramp Valley Voltage	$T_A = 25^{\circ}\text{C}$	0.86	0.95		V
Sleep/Soft Start/Bootstrap Section					
Sleep Threshold	Measured on SS, $T_A = 25^{\circ}\text{C}$	0.25	0.6	0.8	V
SS Charge Current	$V_{SS} = 2.5\text{V}$	4	6	10	μA

ELECTRICAL CHARACTERISTICS: Unless otherwise stated these specifications apply for $T_A = -55^{\circ}\text{C}$ to $+125^{\circ}\text{C}$ for UC1874; $T_A = -25^{\circ}\text{C}$ to $+85^{\circ}\text{C}$ for UC2874; 0°C to $+70^{\circ}\text{C}$ for UC3874; $V_{CC} = 12\text{V}$, $C_t = 680\text{pF}$, $C_{CAP} = 1\mu\text{F}$; $C_{BOOT} = 0.1\mu\text{F}$; $T_A = T_J$.

PARAMETER	TEST CONDITIONS	MIN	TYP	MAX	UNITS
SS Discharge Current	$V_{SS} = 2.5\text{V}$	0.5	0.8		mA
Sleep/Soft start/Bootstrap Section (continued)					
Bootstrap Regulation Voltage	UCX874-2, Low Driver ON	9.5	10.2	12.5	V
	UCX874-1, Low Driver ON	6	7.5	9	V
Bootstrap Refresh Voltage	UCX874-2, $V_{CAOUT} > V_{CTPEAK}$	7	8	9	V
	UCX874-1, $V_{CAOUT} > V_{CTPEAK}$	2.7	3.5	4	V
High Side Driver Output Section					
Output High Voltage	$I_{OUT} = -50\text{mA}$, Boot = 23V	21	22.2		V
Output Low Voltage	$I_{OUT} = 50\text{mA}$		1	2.2	V
	$I_{OUT} = 10\text{mA}$		300	500	mV
Output Low (UVLO)	$I_{OUT} = 50\text{mA}$, $V_{CC} = 0\text{V}$		0.9	1.5	V
Output Rise Time	$C_{OUT} = 1\text{nF}$		40	160	ns
Output Fall Time	$C_{OUT} = 1\text{nF}$		30	100	ns
Low Side Driver Output Section					
Output High Voltage	$I_{OUT} = -50\text{mA}$, $V_{CAP} = 11\text{V}$	8.8	9.5		V
Output Low Voltage	$I_{OUT} = 50\text{mA}$		1	2.2	V
	$I_{OUT} = 10\text{mA}$		300	500	mV
Output Low (UVLO)	$I_{OUT} = 50\text{mA}$, $V_{CC} = 0\text{V}$		0.9	1.5	V
Output Rise/Fall Time	$C_{LOAD} = 1\text{nF}$		40	160	ns
Output Fall Time	$C_{OUT} = 1\text{nF}$		30	100	ns
X10 Amplifier Section					
Gain	$V_{ISNS} \pm V_{ISNS} = 20\text{mV}$ to 80mV	9.2	9.8	10.4	V/V
Slew Rate Rising	$T_A = 25^{\circ}\text{C}$	1	1.4		V/ μs
Slew Rate Falling	$T_A = 25^{\circ}\text{C}$	2	3.5		V/ μs
Input Resistance	$T_A = 25^{\circ}\text{C}$	60	100	165	k Ω

PIN DESCRIPTIONS

BOOT: This pin provides the high side rail for the HDRIVE output. An external capacitor (C_{BST}) is connected between this pin and the drain of the external low side MOSFET. When the low side MOSFET is conducting C_{bst} is charged to 11V via an external diode tied to CAP. When the low side MOSFET turns off and the high side MOSFET turns on, the C_{bst} bootstraps itself up with the source of high side MOSFET, ultimately providing a 10V V_{gs} for the upper MOSFET. Since this 10V is referenced to the source of the high side N-channel MOSFET, the actual voltage on BOOT and HDRIVE is approximately 10V above V_{CC} while the high side MOSFET is conducting. The voltage on BOOT is continuously monitored during low input voltage conditions when the duty cycle equals approximately 100% to insure that a sufficient gate drive level is being supplied by the UC3874. If the voltage on BOOT falls below 8V (UC3874-2) or 3.5V (UC3874-1), the IC forces

the low side driver to cycle itself on for the few cycles required to replenish C_{BST} . In this way, virtual 100% duty cycle operation is provided.

CA-: This is the inverting input to the current amplifier. Connect a series resistor and capacitor between this pin and CAOUT to set the current loop compensation. An input resistor between this pin and ISOUT provides the inductor current sense signal to the amplifier and also sets the high frequency gain of the amplifier. The common mode operating range for this input is between GND and 4V. The normal range during operation is between 2V and 3V.

CAOUT: This is the output of the wide bandwidth current amplifier and one of the inputs to the PWM duty cycle comparator. The output signal generated by this amplifier commands the PWM to force the correct duty cycle to maintain output voltage in regulation. The output can swing from 0.1V to 4V.

CAP: A capacitor is normally connected between this pin and GND providing bypass for the internal 11V regulator. Charge is transferred from this capacitor to CBST via an external diode when the low side MOSFET is conducting. If $VCC \leq 10V$ logic level MOSFETs are generally specified. CAP should then be shorted to VCC in conjunction with a low VF Schottky to BOOT to maximize the gate drive amplitude. This technique provides adequate gate drive signal amplitudes with VCC as low as 4.5V. For high input voltage applications, a simple external shunt zener regulator circuit can be connected to CAP, thereby offloading power dissipation requirements from the IC to an external transistor.

COMP: This is the output of the voltage amplifier. It provides the current command signal to the current amplifier. The voltage is clamped to approximately 3.2V.

CT: A capacitor from CT to GND sets the PWM oscillator frequency according to the following equation:

$$F = \frac{1}{14250 \cdot CT}$$

Use a high quality ceramic capacitor with low ESL and ESR for best results. A minimum CT value of 220pF insures good accuracy and less susceptibility to circuit layout parasitics. The oscillator and PWM are designed to provide practical operation to 300kHz.

GND: All voltages are measured with respect to this pin. All bypass capacitors and timing components except those listed under the PGND pin description should be connected to this pin. Component leads should be as short and direct as possible.

HDRIVE, LDRIVE: The outputs of the PWM are totem pole MOSFET gate drivers on the HDRIVE and LDRIVE pins. The outputs can sink approximately 1A and source 500mA. This characteristic optimizes the switching transitions by providing a controlled dV/dT at turn-on and a lower impedance at turn-off. These are complementary outputs with a typical deadtime of 200ns. Internal circuitry prevents the possibility of simultaneous conduction of the output MOSFETs (shoot through). HDRIVE is the high side bootstrapped output. Its upper power supply rail is the BOOT pin which means that its output will fly approximately 10V above VCC when the upper side of the totem pole output is conducting. The power supply rail for LDRIVE is CAP. As a result the Vgs of both gates are regulated to approximately 10V if VCC is >11V. A series resistor between these pins and the MOSFET gates of at least 10 ohms can be used to control ringing. Additionally, a low VF Schottky diode should be connected between these pins and GND to prevent substrate conduction and possible erratic operation.

ISNS-: This is the inverting input to the X10 instrumentation amplifier. The common mode input range for this pin extends from GND to VCC. A low value resistor in series with the output inductor is connected between this pin and ISNS+ to develop the current sense signal.

ISNS+: This is the non-inverting input to the X10 instrumentation amplifier. The common mode input range for this pin extends from GND to VCC.

ISOUT: This is the output of the X10 instrumentation amplifier. The output voltage on this pin is level shifted 2V above GND, such that if a 100mV differential input is applied across ISNS+ and ISNS-, the output will be 3V.

PGND: This is the high current ground for the IC. The MOSFET driver transistors are referenced to this ground. For best performance an external star ground connection should be made between this pin, the source of the low side MOSFET, the capacitor on CAP, the anodes of any external Schottky clamp diodes and the output filter capacitor. As with all high frequency layouts, a ground plane and short leads are highly recommended.

SB: The voltage on SB sets the output current level at which standby mode is initiated. A voltage level from 0V to 1V programs the threshold from 50% to 0% of full load current. Full load current corresponds to a 100mV differential signal across the ISNS inputs. Since this is a high impedance input, a voltage divider derived from VREF may be used to program this level. Another possible use is to actively control this level with external circuitry to adaptively control converter efficiency. Tying SB to VREF disables standby mode operation.

SS: A capacitor from this pin to GND in conjunction with an internal 10mA current source provides a soft start function for the IC. The voltage level on SS clamps the output of the voltage amplifier through an internal buffer, thus providing a controlled startup. The SS time is approximately:

$$\frac{C_{SS} \cdot \frac{V_o}{V_{IN}} \cdot 3V}{10\mu A}$$

Once the device has completed its soft start cycle, a low power sleep mode can be invoked by pulling SS below 0.5V typically. In sleep mode, all of the device functions are disabled except for those which are required to bring the device out of sleep mode when SS is released. Typical sleep mode supply current is less than 50mA.

VCC: Positive supply rail for the IC. Bypass this pin to GND with a 1mF low ESL/ESR ceramic capacitor. The maximum voltage for VCC is 36V. The turn on voltage level on VCC is 4.5V with 100mV of hysteresis for the

UC3874-1 and 10V with 1V of hysteresis for the UC3874-2.

VREF: VREF is the output of the precision reference. The output is capable of supplying 20mA to peripheral circuitry and is internally short circuit current limited. VREF is disabled and low whenever VCC is below the UVLO threshold, and when SS is pulled below 0.5V. A VREF “good” comparator senses VREF and disables the

PWM stage until VREF has attained approximately 90% of its nominal value. Bypass VREF to GND with a 0.1mF ceramic capacitor for best performance.

VSNS: This pin is the inverting input of the voltage amplifier and serves as the output voltage feedback point for the synchronous regulator. It senses the output voltage through a voltage divider which produces a nominal 2.0V.

APPLICATION DIAGRAM

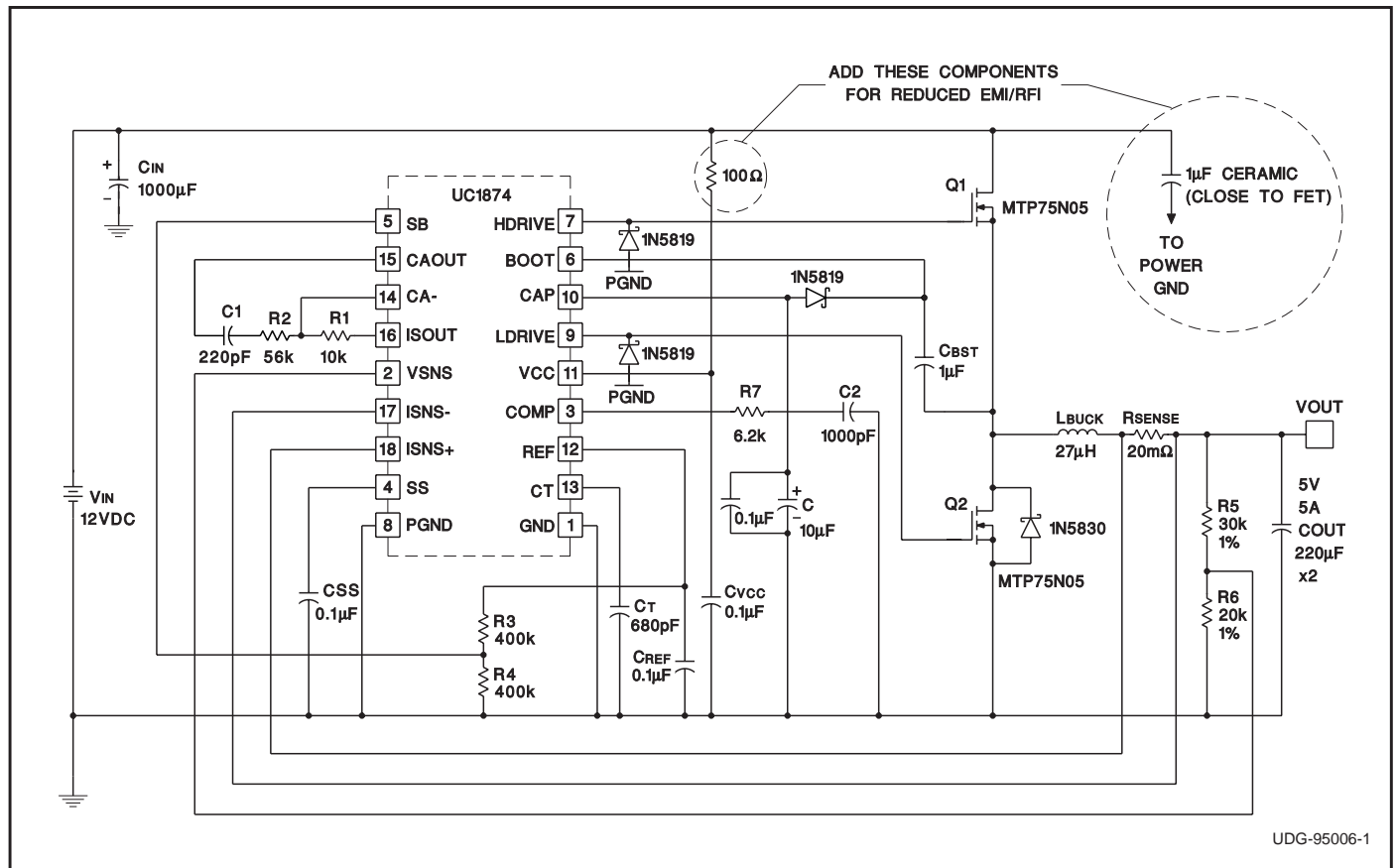

OPERATION: Refer to 5V, 25W Application Schematic

The UC3874 employs a fixed frequency average current mode control buck topology to convert a higher battery voltage down to a tightly regulated output voltage. Special design techniques allow this bipolar IC to deliver exceptional performance while consuming approximately 6mA of supply current over an input voltage range of 4.5 to 35 volts. Fixed frequency operation allows synchronization to an existing system clock, and easier filtering. Average current mode control provides inherent slope compensation and accurate short circuit current limiting. An additional benefit is its ability to maintain a constant regulator gain regardless of whether the inductor current is continuous or discontinuous.

The output inductor current is sensed by an external low value shunt resistor (Rsense). This signal at full load current should be no larger than 100mV in order to minimize sensing losses. The differential voltage across Rsense is amplified by the internal X10 instrumentation amplifier. The common mode input range for this amplifier extends from GND to VCC in order to maintain accurate current sensing under normal conditions as well as abnormal conditions such as output short circuit and low drop out (LDO) modes. The output of the X10 instrumentation amplifier is applied to the inverting input of the current amplifier through an external resistor. The converter's output voltage feedback is applied to the

VSNS pin through an external voltage divider. The difference between the voltage at VSNS and the internal reference level at the non-inverting input is amplified by the voltage amplifier and applied to the non-inverting input of the current amplifier. This instantaneous reference level forms the current command input for the average current control loop. The average current amplifier develops the duty cycle command signal by integrating the current feedback signal with respect to the instantaneous current command input. This output is compared to the fixed high amplitude oscillator ramp waveform at the inputs of the PWM comparator to develop duty cycle information for the PWM drive. The large amplitude oscillator ramp provides both high noise margin and built-in slope compensation in average current mode control methodology. The fixed frequency oscillator is programmed with a single external capacitor connected between CT and GND, and is capable of switching frequencies up to 300kHz. The UC3874 can be synchronized to an external clock by capacitively coupling the signal to the junction of the capacitor at CT and a low value resistor tied to GND. Refer to Application Note U-111.

The PWM drive signal is applied to the complementary output driver stages. Since the high side switch is an N-channel MOSFET, a means for driving its gate above VCC is required. This is accomplished via the internal 11V regulator and an external capacitor (CBST). CBST is charged through an external diode to VCC or CAP when the low side MOSFET is on. The charging level on Cbst is internally regulated to 11V minus an external diode drop by the UC3874 as long as VCC is above 11V. When the low side MOSFET turns off, CBST is applied across the gate to the source of the upper MOSFET allowing it to begin turn-on. As the upper MOSFET turns on, it lifts or bootstraps the low end of CBST, along with its source. Shortly thereafter, the source voltage level is reduced by $R_{DS(on)} \cdot I_{load}$ below VCC. When $V_{CC} < 10V$, V_{gs} for the high side MOSFET is approximately equal to VCC. If $V_{CC} < 8V$, logic level MOSFETs are recommended. In these applications, CAP should be shorted to VCC and an external Schottky diode is connected between CAP/VCC and BOOT. For low battery applications, a synchronous regulator must be capable of LDO or 100% duty cycle operation. The UC3874 includes circuitry to insure that this mode of operation is possible even though it uses a bootstrapped drive technique for the high side MOSFET. During commanded 100% duty cycle operation, the UC3874 monitors the V_{gs} drive signal applied to the high side MOSFET, and automatically provides complementary pulses to refresh the bootstrap capacitor when this voltage falls below a set threshold. In this way, near 100% duty cycle operation is possible, with

effective duty cycle dependent only upon the value of CBST.

High efficiency is obtained primarily by the low side MOSFET which replaces the Schottky diode in the standard buck configuration. Its low $R_{ds(on)}$ produces a much lower voltage drop than a low VF Schottky diode. As output voltages get lower, these improvements become more evident. Additional efficiency improvements at light regulator load currents are obtained by automatic switchover to standby mode. In standby mode, the UC3874 disables its MOSFET drivers and oscillator saving both quiescent supply current consumption and more importantly MOSFET gate drive charge current. Standby mode is initiated when the output inductor current has dropped to a user programmable fraction of the designed full load current. Programmability is easily attained by setting the SB pin to a voltage level between 0V and 1V, which corresponds to 50% to 0% of the peak load current. In this manner, the user can accurately determine when standby mode is initiated, giving the flexibility to directly shape the efficiency vs. load curve. In standby mode, all output current requirements are handled by the output capacitor. Since the output capacitor isn't being refreshed by the PWM converter, the output voltage will decay at a rate determined by the load current and the output capacitor value:

$$\frac{dV}{dT} = \frac{I_{LOAD}}{C_{OUT}}$$

Normal operation returns when the output voltage has decayed by approximately 1% from its nominal value. Standby operation can be easily disabled by connecting the SB pin directly to VREF. Another efficiency consideration is the possibility of reverse current in the output inductor. For a non-synchronous regulator this isn't a problem since the diode will block reverse current, allowing discontinuous inductor current operation at light loads. Since the synchronous regulator replaces the diode with a switch, reverse current can and will flow if the low side switch is on when the inductor is depleted. The UC3874 includes circuitry to prevent reverse current from flowing in the inductor by disabling the low side gate drive signal during discontinuous mode operation. This increases efficiency by eliminating unnecessary I^2R losses in the MOSFET and the inductor.

Soft start is recommended for Buck converters to reduce stress on the power components during startup, and to reduce overshoot of the output voltage. This improves reliability. The UC3874 includes a user programmable soft start pin to implement this feature. An internal 10mA current source charges the external soft start capacitor which provides a clamp at the output of the voltage

amplifier. An ultra low power sleep mode is also invoked from the SS pin. A voltage level below 0.5V on this pin reduces total standby current to less than 50mA. Short circuit protection is inherent to the average current mode technique with proper compensation of the current amplifier. To prevent operation of the MOSFETs with an inadequate drive signal, an undervoltage lockout circuit suppresses the output drivers until the input supply

voltage is sufficiently high enough for proper operation. The UC3874-1 is intended for applications with logic level MOSFETs and its VCC turn-on and turn-off thresholds are 4.5V/4.4V respectively. The UC3874-2 is intended for applications with standard MOSFETs and has UVLO turn-on and turn-off thresholds of 10V and 9V respectively. The precision 2.5V reference can provide 20mA to power external circuitry. The reference output is disabled during UVLO and sleep modes.

ORDERING INFORMATION

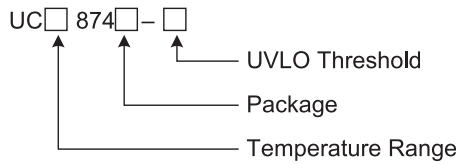

UVLO Turn On/Off Threshold	Package	Temperature Range
1: 4.5V/4.4V	J: Ceramic DIL-18	1: -55°C to +125°C
2: 10V/9V	N: Plastic DIL-18	2: -40°C to +85°C
	DW: SOIC-18	3: 0°C to +70°C

TYPICAL PERFORMANCE INFORMATION

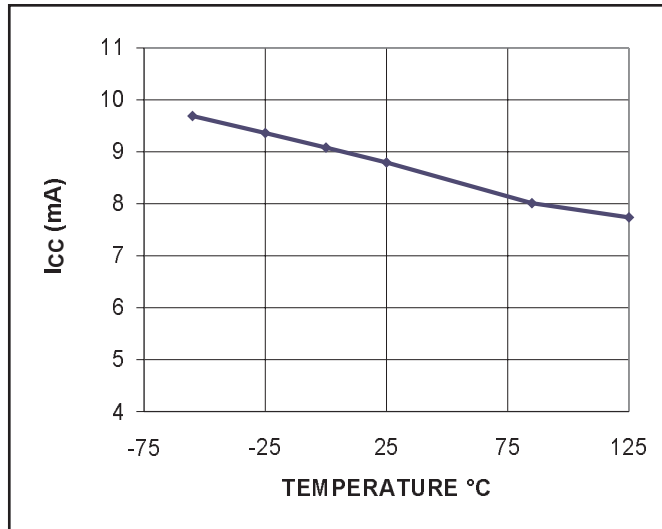

Figure 1. Supply Current

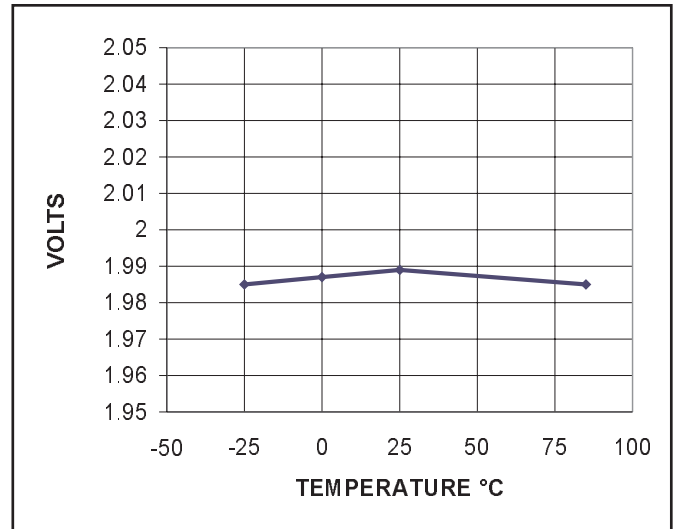

Figure 2. VAMP Input Voltage

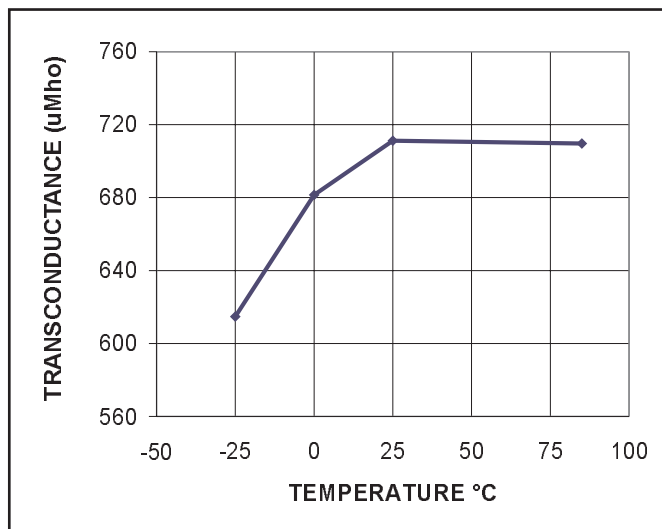

Figure 3. Volt Amp GM (I_{OUT} = ± 10μA)

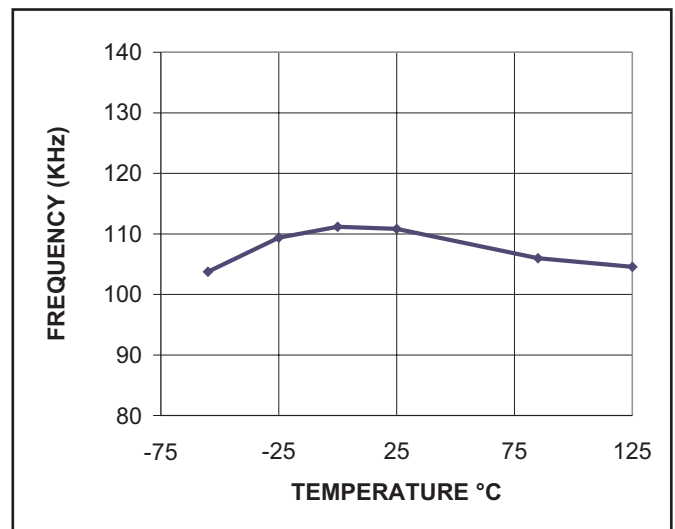

Figure 4. Oscillator Frequency vs. Temperature (CT = 680pF)

PERFORMANCE INFORMATION (continued)

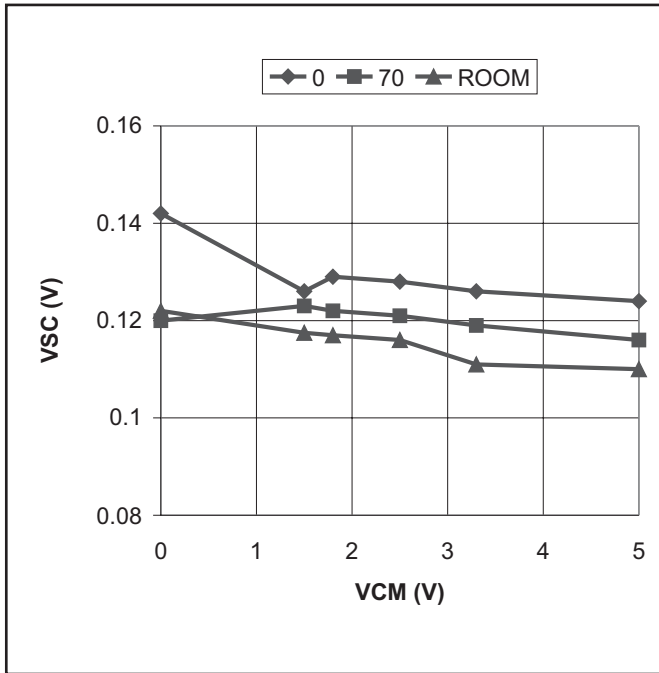

Figure 5. Short Circuit Limit Voltage Reflected to Input of Current Amp vs. Current Amp Common Mode Voltage

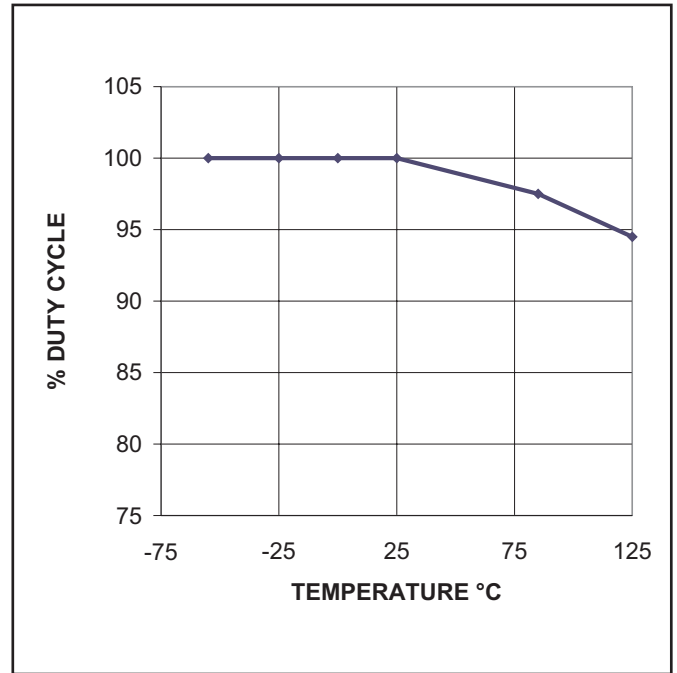

Figure 6. High Drive Maximum Duty Cycle (UC1874-1,-2)

IMPORTANT NOTICE

Texas Instruments and its subsidiaries (TI) reserve the right to make changes to their products or to discontinue any product or service without notice, and advise customers to obtain the latest version of relevant information to verify, before placing orders, that information being relied on is current and complete. All products are sold subject to the terms and conditions of sale supplied at the time of order acknowledgement, including those pertaining to warranty, patent infringement, and limitation of liability.

TI warrants performance of its semiconductor products to the specifications applicable at the time of sale in accordance with TI's standard warranty. Testing and other quality control techniques are utilized to the extent TI deems necessary to support this warranty. Specific testing of all parameters of each device is not necessarily performed, except those mandated by government requirements.

CERTAIN APPLICATIONS USING SEMICONDUCTOR PRODUCTS MAY INVOLVE POTENTIAL RISKS OF DEATH, PERSONAL INJURY, OR SEVERE PROPERTY OR ENVIRONMENTAL DAMAGE ("CRITICAL APPLICATIONS"). TI SEMICONDUCTOR PRODUCTS ARE NOT DESIGNED, AUTHORIZED, OR WARRANTED TO BE SUITABLE FOR USE IN LIFE-SUPPORT DEVICES OR SYSTEMS OR OTHER CRITICAL APPLICATIONS. INCLUSION OF TI PRODUCTS IN SUCH APPLICATIONS IS UNDERSTOOD TO BE FULLY AT THE CUSTOMER'S RISK.

In order to minimize risks associated with the customer's applications, adequate design and operating safeguards must be provided by the customer to minimize inherent or procedural hazards.

TI assumes no liability for applications assistance or customer product design. TI does not warrant or represent that any license, either express or implied, is granted under any patent right, copyright, mask work right, or other intellectual property right of TI covering or relating to any combination, machine, or process in which such semiconductor products or services might be or are used. TI's publication of information regarding any third party's products or services does not constitute TI's approval, warranty or endorsement thereof.