

S3098

DEVICE SPECIFICATION

SONET/SDH/ATM OC-192 1:16 Low Power Receiver w/CDR/Postamp

FEATURES

- Low power operation
- Silicon Germanium BiCMOS technology
- Complies with Telcordia and ITU-T specifications
- Supports G.709 and 10 Gigabit Ethernet rates
- Supports OC-192 to OC-192 with Forward Error Correction (FEC) rates
- Integrated phase lock loop
- Postamp on serial input
- VCO Tunable from 9.953 GHz to 10.709 GHz
- 155.52 MHz REFCLK input (or equivalent FEC rate)
- 16-bit parallel, 622.08 Mbps LVDS data path (or equivalent FEC rate)
- Lock detect indicator
- Low jitter CML differential or single-ended serial interface
- Recovered 622.08 MHz clock output (or equivalent FEC rate)
- Accepts Active High or Active Low signal detect inputs for loss of light (programmable)
- Accepts LVCMOS or LVPECL signal detect inputs
- Synthesizes parallel output clock during loss-of-signal conditions
- Power 1.3 W (typ)
- Compact 15 mm x 15 mm 148-pin CBGA package

APPLICATIONS

- SONET/SDH-based transmission systems
- SONET/SDH modules
- SONET/SDH test equipment
- ATM over SONET/SDH
- Section repeaters
- Add Drop Multiplexers (ADM)
- Broad-band cross-connects
- Fiber optic terminators
- Fiber optic test equipment

GENERAL DESCRIPTION

The S3098 low power 1:16 receiver with Clock/Data Recovery (CDR) and integrated postamp is a fully integrated OC-192 deserialization/clock and data recovery device. The S3098 receives an OC-192 scrambled NRZ serial signal and recovers the clock. This recovered clock is then used to re-time and demultiplex the data into 16 parallel lines. If a loss-of-signal condition occurs (or LCKREFN is asserted Low), the internal Phase Lock Loop (PLL) will lock to the local 155.52 MHz Reference Clock (REFCLK) (or equivalent FEC rate) to provide a stable clock for down-stream purposes. The S3098 has a limiting postamp on the serial input for small signal gain.

The low jitter LVDS interface guarantees compliance with the bit error rate requirements of the Telcordia and ITU-T standards. Figure 1, *System Block Diagram*, shows a typical network application.

Figure 1. System Block Diagram

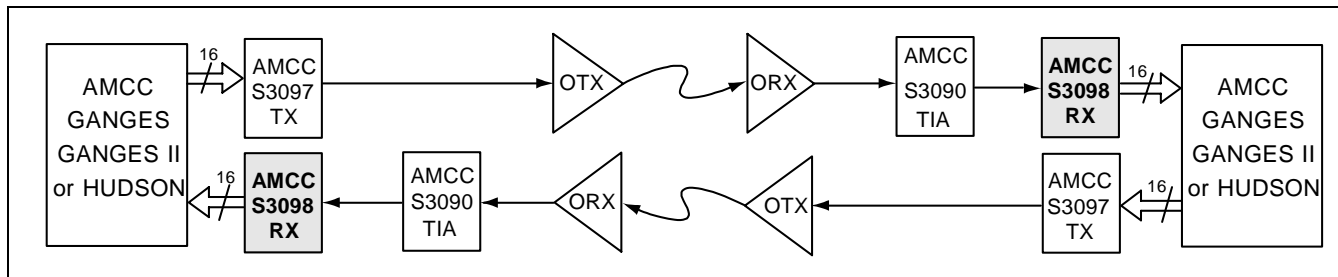

CONTENTS

| | |
|--|-----------|
| FEATURES | 1 |
| APPLICATIONS | 1 |
| GENERAL DESCRIPTION | 1 |
| CONTENTS | 2 |
| FIGURES | 3 |
| TABLES | 3 |
| S3098 OVERVIEW | 4 |
| Suggested Interface Devices | 4 |
| S3098 PIN DESCRIPTION | 6 |
| Serial Data In (SERDATIP/N) | 6 |
| Reference Clock (REFCLKP/N) | 6 |
| Loop Filter (CAP1, CAP2) | 6 |
| Lock to Reference (LCKREFN) | 6 |
| Signal Detect (SDLVPECLN/SDLVCMOSN) | 6 |
| Reset (RSTB) | 6 |
| Factory Test (TSTSIG, TESTB) | 6 |
| Parallel Output Clock (POCLKP/N) | 7 |
| Parallel Output Data (POUTP/N[15:0]) | 7 |
| Lock Detect (LOCKDET) | 7 |
| Recovered 622.08 MHz Clock (RX622MCKP/N) | 7 |
| S3098 FUNCTIONAL DESCRIPTION | 8 |
| Receiver Description | 8 |
| Postamp | 8 |
| Clock Recovery | 8 |
| Lock Detect | 8 |
| Serial-to-Parallel Converter | 8 |
| Power Sequencing | 8 |
| ORDERING INFORMATION | 23 |

FIGURES

| | |
|--|----|
| Figure 1. System Block Diagram | 1 |
| Figure 2. Functional Block Diagram | 5 |
| Figure 3. S3098 Pinout (Top View) | 12 |
| Figure 4. Compact 15 mm x 15 mm 148-pin CBGA Package | 13 |
| Figure 5. Parallel Data Output Delay from POCLK | 19 |
| Figure 6. Differential Voltage Measurement | 19 |
| Figure 7. Single-Ended Data Input Voltage Measurement | 20 |
| Figure 8. S3098 LVDS Output to LVDS Input | 20 |
| Figure 9. -5.2 V ECL Post Amp to S3098 Input DC Coupled Termination | 20 |
| Figure 10. -5.2 V ECL TIA to S3098 DC Coupled Termination | 21 |
| Figure 11. +3.3 V Differential LVPECL Driver to S3098 LVPECL Reference Clock Input, AC Coupled Termination | 21 |
| Figure 12. External Loop Filter | 21 |
| Figure 13. Single-Ended Termination Scheme | 22 |

TABLES

| | |
|--|----|
| Table 1. Reference Frequency | 6 |
| Table 2. SDLVCMOSN Connections when using SDLVPECLN Input | 6 |
| Table 3. SDLVPECLN Connections when using SDLVCMOSN Input | 6 |
| Table 4. Input Pin Description and Assignment | 9 |
| Table 5. Output Pin Descriptions and Assignment | 10 |
| Table 6. Common Pin Descriptions and Assignment | 11 |
| Table 7. Package Thermals | 13 |
| Table 8. Performance Specifications | 14 |
| Table 9. Absolute Maximum Ratings | 15 |
| Table 10. Recommended Operating Conditions | 16 |
| Table 11. Internally Biased Differential CML Input DC Characteristics | 16 |
| Table 12. LVDS Output Characteristics | 17 |
| Table 13. Internally Biased Differential LVPECL Input DC Characteristics (REFCLKP/N) | 17 |
| Table 14. Single-Ended LVPECL Input DC Characteristics (SDLVPECLN) | 17 |
| Table 15. LVCMOS Input DC Characteristics | 18 |
| Table 16. LVCMOS Output DC Characteristics | 18 |
| Table 17. AC Characteristics | 18 |
| Table 18. External Loop Filter Components | 19 |

S3098 OVERVIEW

The S3098 Clock and Data Recovery Unit (CDR) with Demultiplexer (DeMUX) implements SONET/SDH deserialization functions. Figure 2, *Functional Block Diagram*, shows the basic operation of the chip. This chip can be used to implement the front end of the SONET equipment, which consists primarily of the parallel transmit interface and the serial receive interface. The chip includes clock and data recovery, serial-to-parallel conversion and system timing. The sequence of receiver operations of the S3098 is as follows:

1. Serial input to limiting postamp
2. Clock and data recovery
3. Serial-to-parallel conversion
4. 16-bit parallel output

Suggested Interface Devices

| | | |
|------|-------------------------|--------------------------|
| AMCC | GANGES (S19202) | OC-192 Mapper |
| AMCC | GANGES II (S19202CBI20) | OC-192 Mapper |
| AMCC | HUDSON (S19203) | Framer, Digital Wrapper |
| AMCC | MEKONG (S19204) | OC-192 Pointer Processor |
| AMCC | S2509 | Quad backplane device |
| AMCC | S3090 | 10 Gbps TIA |
| AMCC | S3095 | 10 Gbps TIA with AGC |
| AMCC | S3097 | OC-192 Transmitter |
| AMCC | S3196 | 10 Gbps Limiting Amp |

Figure 2. Functional Block Diagram

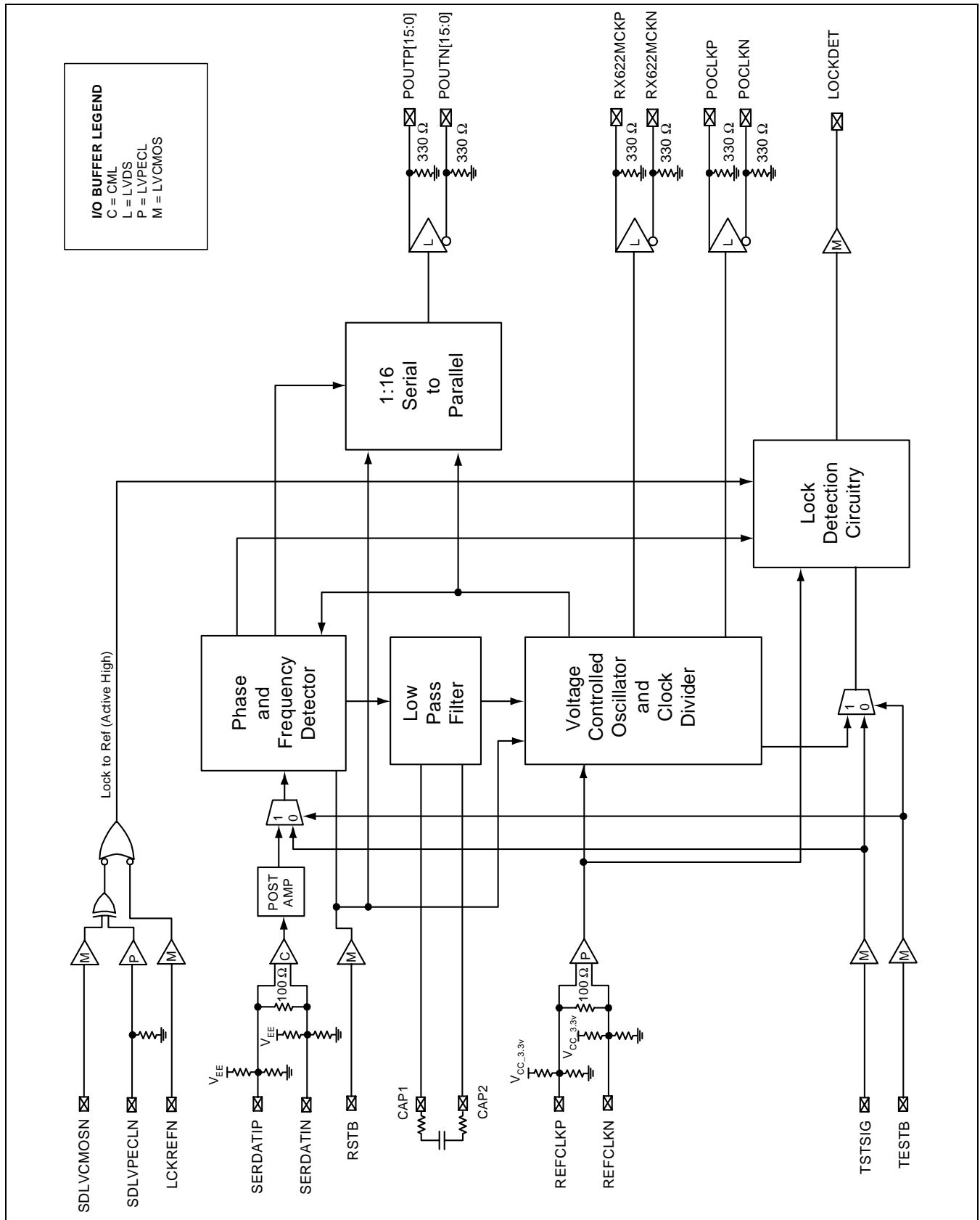

S3098 PIN DESCRIPTION

Serial Data In (SERDATIP/N)

The Serial Data In (SERDATIP/N) pins are differential Current Mode Logic (CML) inputs. They receive inputs from an optics module or other upstream logic device. The S3098 extracts the clock from the SERDATIP/N inputs and provides a recovered clock (POCLKP/N) with re-timed parallel data. These pins are internally biased and terminated 100 Ω line-to-line.

Reference Clock (REFCLKP/N)

The Reference Clock (REFCLKP/N) pins are an LVPECL 155.52 MHz (or equivalent FEC rate) input used to establish the initial operating frequency of the clock recovery PLL. The REFCLKP/N is also used in the absence of data to maintain PLL lock. This input is internally biased and terminated 100 Ω line-to-line. Most implementations may require AC coupling. See Table 1, *Reference Frequency*, for REFCLK requirements.

Loop Filter (CAP1, CAP2)

The external loop filter capacitor and resistors are connected to the CAP1 and CAP2 pins. These devices should be surrounded by a ground shield. Component values should be as stated in Table 18, *External Loop Filter Components*.

Lock to Reference (LCKREFN)

The LVC MOS Lock to Reference (LCKREFN) signal, when asserted Low, will force the PLL to lock to the local Reference Clock (REFCLK) as well as de-assert LOCKDET.

Signal Detect (SDLVPECLN/SDLVCMOSN)

Two types of signal detect inputs (SDLVPECLN/SDLVCMOSN) are provided, LVPECL and LVC MOS. The LVPECL input should be driven by optical transceivers with an LVPECL signal detect output, and the LVC MOS input should be driven by optical transceivers with an LVC MOS signal detect output. The LVPECL input is internally pulled down. These inputs may be used with optics modules that are either active Low or active High for loss of light.

An optics module with an LVPECL output should be connected to the SDLVPECLN input. Connect SDLVCMOSN as shown in Table 2, *SDLVCMOSN Connections when using the SDLVPECLN Input*.

An optics module with an LVC MOS output should be connected to the SDLVCMOSN input. Connect SDLVPECLN as shown in Table 3, *SDLVPECLN Connections when using the SDLVCMOSN Input*.

Table 1. Reference Frequency

| Input Data Rate (SERDATIP/N) | Required Reference Frequency (REFCLK) |
|------------------------------|---------------------------------------|
| 9.953 Gbps | 155.52 MHz |
| 10.234 Gbps | 159.91 MHz |
| 10.317 Gbps | 161.20 MHz |
| 10.402 Gbps | 162.53 MHz |
| 10.488 Gbps | 163.87 MHz |
| 10.575 Gbps | 165.23 MHz |
| 10.664 Gbps | 166.63 MHz |
| 10.709 Gbps | 167.33 MHz |

Table 2. SDLVCMOSN Connections when using SDLVPECLN Input

| | Optics Device Active Low for loss of light | Optics Device Active High for loss of light |
|------------------|--|---|
| SDLVCMOSN | Connect to GND | Connect to V _{CC_2.5V} |

Table 3. SDLVPECLN Connections when using SDLVCMOSN Input

| | Optics Device Active Low for loss of light | Optics Device Active High for loss of light |
|------------------|--|--|
| SDLVPECLN | Connect to GND | Connect to V _{CC_3.3V} ¹ |

1. Connecting to V_{CC_3.3V} is permitted under static conditions.

Reset (RSTB)

The master Reset (RSTB) LVC MOS pin, when asserted Low, asynchronously resets the device. For normal operation, connect to V_{CC_2.5V} through a 10 kΩ resistor. This should be active for 100 ns to accurately reset the device.

Factory Test (TSTSIG, TESTB)

Two LVC MOS factory test (TSTSIG, TESTB) pins are for test factory purposes only. For normal operation, connect to V_{CC_2.5V} through a 10 kΩ resistor.

Parallel Output Clock (POCLKP/N)

The Parallel Output Clock (POCLKP/N) LVDS output is an internally regenerated clock which is used to transfer demultiplexed data from an internal holding register to the output register, which drives POUTP/N [15:0]. This clock is synchronized with the parallel output data and must be inverted (cross traces on printed wire board) to be OIF compliant from the module perspective. The parallel outputs are internally terminated with 330 Ω to ground (GND).

Parallel Output Data (POUTP/N[15:0])

The Parallel Output Data (POUTP/N[15:0]) LVDS outputs are re-timed data, output from the Demultiplexer (Demux) at a rate of 622.08 Mbps (or equivalent FEC rate). Bit 15 is the most significant bit and is the first received. The data is re-timed and synchronized to the Parallel Output Clock (POCLKP/N). These outputs are internally terminated with 330 Ω to GND. This bus is typically connected to a framer, mapper or digital wrapper (e.g. GANGES II, GANGES, MEKONG, or HUDSON).

Lock Detect (LOCKDET)

When the LVCMOS output Lock Detect (LOCKDET) signal is inactive (Low), it indicates that the incoming data stream has failed the frequency test, as dictated by the PLL, or LCKREFN has been asserted Low, or SDLVCMOSN/SDLVPECL has been asserted. This test is used to determine whether or not serial input activity is valid data. When LOCKDET is active, the PLL is locked to the data stream.

Recovered 622.08 MHz Clock (RX622MCKP/N)

The LVDS 622.08 MHz Clock (or equivalent FEC rate) (RX622MCKP/N) is the clock which is recovered from the input data stream. During loss-of-signal conditions or when LCKREFN has been asserted, this output clock is derived from the Reference Clock Input (REF-CLKP/N). This is internally terminated with 330 Ω to ground (GND).

S3098 FUNCTIONAL DESCRIPTION

Receiver Description

The S3098 receiver chip provides the first stage of the digital processing of a receive SONET OC-192 bit-serial stream. It converts the bit-serial 9.953 Gbps data stream into a 622.08 Mbps (or equivalent FEC rate) 16-bit parallel data format.

Postamp

The S3098 limiting postamp takes the differential serial data from the SERDATIP/N pins and provides 36 dB of small signal gain. The input to the postamp can be either AC or DC coupled.

Clock Recovery

The clock recovery circuitry generates a clock that is the same frequency as the incoming data bit rate at the serial data input. The clock is phase aligned by a Phase Lock Loop (PLL) so that it samples the data in the center of the data eye pattern.

The Clock and Data Recovery (CDR) extracts a synchronous signal from the serial data input using a PLL. The PLL consists of a Voltage Controlled Oscillator (VCO), Phase/Frequency Detectors (PFD), and a loop filter.

The frequency detector ensures predictable lock-up conditions. It is used during acquisition and serves as a means to pull the VCO into the range of the data rate at which the phase detector is capable of acquiring lock.

The phase detector used in the CDR is designed to give minimum static phase error of the PLL. When a transition has occurred, the value of the sample in the vicinity of the transition tells whether the VCO clock leads or lags the incoming data, and the phase detector produces a binary output accordingly.

When a loss-of-signal condition exists, Signal Detect (SDLVCMOSN or SDLVPECLN) will be de-asserted, and the PLL locks onto the Reference Clock (REFCLK) to provide a steady output clock. There are two pins (CAP1 and CAP2) to connect the external capacitor and resistors in order to adjust the PLL loop performance.

The phase relationship between the edge transitions of the data and those of the generated clock are compared by a phase/frequency discriminator. Output pulses from the discriminator indicate the required direction of phase corrections. These pulses are

smoothed by an integral loop filter. The output of the loop filter controls the frequency of the Voltage Controlled Oscillator (VCO), which generates the recovered clock.

The loop filter transfer function is optimized to enable the PLL to track the jitter, yet tolerate the minimum transition density expected in a received SONET data signal.

The total loop dynamics of the clock recovery PLL yield a jitter tolerance that exceeds the minimum tolerance proposed for SONET equipment by the Telcordia TA-NWT-000253 standard.

Lock Detect

The S3098 contains a lock detect circuit, which monitors the integrity of the serial data inputs. If the received serial data fails the frequency test, the PLL will be forced to lock to the local reference clock. This will maintain the correct frequency of the recovered clock output under loss-of-signal or loss-of-lock conditions. If the recovered clock frequency deviates from the local reference clock frequency by more than the typical value stated in Table 8, *Performance Specifications*, the PLL will be declared out of lock. The phase detect circuit will poll the input data stream in an attempt to reacquire lock to data. If the recovered clock frequency is determined to be within the typical value stated in Table 8, *Performance Specifications*, the PLL will be declared in lock, and the lock detect output will go active. A de-asserted signal detect (SDLVCMOSN or SDLVPECLN) will also cause an out-of-lock condition.

Serial-to-Parallel Converter

The serial-to-parallel converter consists of three 16-bit registers. The first is a serial-in, parallel-out shift register, which performs the serial-to-parallel conversion. The second is a 16-bit internal holding register, which transfers data from the serial-to-parallel register on byte boundaries. On the falling edge of the Parallel Output Clock (POCLK), the data in the holding register is transferred to an output holding register, which drives Parallel Output Data (POUTP/N[15:0]).

Power Sequencing

In order to avoid latch up, the following power-up sequence is required. Apply GND first, next -5.2 V, then the positive supplies, +2.5 V and +3.3 V. These two positive supplies can be brought up simultaneously or in any order.

Table 4. Input Pin Description and Assignment

| Pin Name | Level | I/O | Pin # | Description |
|----------------------|------------------------|-----|----------|--|
| SERDATIP SERDATIN | Diff. CML | I | G1 J1 | Serial Data Input. Differential high frequency serial data input to limiting postamp for small signal gain. Internally biased and terminated 100 Ω line-to-line. |
| REFCLKP REFCLKN | Diff. LVPECL | I | B1 C1 | Reference Clock. Differential reference clock input at 155.52 MHz (or equivalent FEC rate). The PLL will lock onto this reference in the absence of serial input data. Internally biased and terminated 100 Ω line-to-line. |
| CAP1 CAP2 | Analog | I | B4 C4 | Loop Filter. The external loop filter capacitor and resistors are connected to these pins. Used to adjust the loop filter performance. See Figure 12, <i>External Loop Filter</i> and Table 18, <i>External Loop Filter Components</i> . |
| LCKREFN | LVC MOS | I | C14 | Lock to Reference. Active Low. When active, the PLL will be forced to lock to the local reference clock input (REFCLK). If unused, connect to V _{CC_2.5 V} through a 10 kΩ resistor for normal operation. |
| RSTB | LVC MOS | I | A7 | Master Reset. Active Low. Reset input for the device. For correct reset, this input must be asserted Low for 100 ns. Connect to V _{CC_2.5 V} through a 10 kΩ resistor if not used. |
| TESTB | LVC MOS | I | C6 | Test Enable. Active Low. Used during production test to bypass the VCO in the PLL. Connect to V _{CC_2.5 V} through a 10 kΩ resistor for normal operation. |
| TSTSIG | LVC MOS | I | A6 | Test Input. Active Low. Signal used for production test. Connect to V _{CC_2.5 V} through a 10 kΩ resistor for normal operation. |
| SDLVPECLN | Single-Ended LVPECL | I | A9 | Signal Detect. A Single-Ended 10 K LVPECL input to be driven by the external optical receiver module to indicate a loss of received optical power. This input may be utilized by an optics module that is active Low or active High for loss of light. For an active High device, SDLVCMOSN must be connected to V _{CC_2.5 V} through a 10 kΩ resistor. For an active Low optics module, the SDLVCMOSN input must be connected to GND. The optics module LVPECL signal detect output may be directly connected to the SDLVPECLN input. This input is internally pulled Low. When a loss of light condition occurs, the internal PLL will be forced to lock to the REFCLK input signal. |
| SDLVCMOSN | LVC MOS | I | B13 | Signal Detect. A LVC MOS input to be driven by the external optical receiver module to indicate a loss of received optical power. This input may be utilized by an optics module that is active Low or active High for loss of light. For an active Low device, SDLVPECLN must be connected to GND. For an active High optics module, the SDLVPECLN input must be connected to V _{CC_3.3 V} through a 10 kΩ resistor. The optics module LVC MOS signal detect output may be directly connected to the SDLVCMOSN input. When a loss of light condition occurs, the internal PLL will be forced to lock to the REFCLK input signal. |

Table 5. Output Pin Descriptions and Assignment

| Pin Name | Level | I/O | Pin # | Description |
|--|---------|-----|---|--|
| POCLKP POCLKN | LVDS | O | B10 B9 | Parallel Output Clock. Regenerated 622.08 MHz (or equivalent FEC rate) differential output clock, synchronized to the parallel output data. (See Figure 5, <i>Parallel Data Output Delay from POCLK</i>). Internally terminated with 330 Ω to GND. |
| POUT0P POUT0N POUT1P POUT1N POUT2P POUT2N POUT3P POUT3N POUT4P POUT4N POUT5P POUT5N POUT6P POUT6N POUT7P POUT7N POUT8P POUT8N POUT9P POUT9N POUT10P POUT10N POUT11P POUT11N POUT12P POUT12N POUT13P POUT13N POUT14P POUT14N POUT15P POUT15N | LVDS | O | N2 N3 P3 P4 N4 N5 P5 P6 N6 N7 P7 P8 N8 N9 P9 P10 M11 M12 N12 N13 N14 M14 L13 K13 K14 J14 H14 G14 G13 F13 F14 E14 | Parallel Output Data. Re-timed data from the Demultiplexer (DeMUX) at a rate of 622.08 Mbps (or equivalent FEC rate). POUTP/N15 is the most significant bit (corresponding to bit 1 of each word, the first bit received.) POUTP/N0 is the least significant bit corresponding to bit 16 of each word, the last bit received). Internally terminated with 330 Ω to GND. |
| LOCKDET | LVC MOS | O | A12 | Lock Detect. Active High. Clock recovery indicator. Active when the internal clock recovery has locked onto the incoming data stream. LOCKDET is an asynchronous output. |
| RX622MCKP RX622MCKN | LVDS | O | B11 A11 | 622.08 MHz Clock (or equivalent FEC rate) derived from VCO clock. Internally terminated with 330 Ω to GND. |

Table 6. Common Pin Descriptions and Assignment

| Pin Name | Level | I/O | Pin # | Description |
|--------------------|--------|-----|---|---------------------------------------|
| COREVCC | +2.5 V | PWR | B8, C13, M2, M8, M9 | Digital $V_{CC_2.5V} + 2.5V \pm 5\%$ |
| LVDSVCC | +2.5 V | PWR | C9, H13, M3, M6, M13 | LVDS $V_{CC_2.5V} + 2.5V \pm 5\%$ |
| LVC MOSVCC | +2.5 V | PWR | C7 | LVC MOS $V_{CC_2.5V} + 2.5V \pm 5\%$ |
| CMLV _{EE} | -5.2 V | PWR | D1, E2, L2 | CML $V_{EE} -5.2V \pm 5\%$ |
| SUBV _{EE} | -5.2 V | PWR | B12, D13, J13, N11 | Substrate $V_{EE} -5.2V \pm 5\%$ |
| ANALOG AVCC | +3.3 V | PWR | A3, A5 | Analog $V_{CC_3.3V} + 3.3V \pm 5\%$ |
| DIGITALVCC | +3.3 V | PWR | C8 | Digital $V_{CC_3.3V} + 3.3V \pm 5\%$ |
| GND | 0 V | GND | A1, A2, A4, A8, A10, A13, A14, B2, B3, B5, B6, B7, B14, C2, C3, C5, C10, C12, D2, D14, E1, E13, F1, F2, H1, H2, K1, K2, L1, L14, M1, M4, M5, M7, M10, N1, N10, P1, P2, P11, P12, P13, P14 | Analog/Digital Ground |
| THERMAL GND | 0 V | GND | E6, E7, E8, E9, E10, F5, F6, F7, F8, F9, F10, G5, G6, G7, G8, G9, G10, H5, H6, H7, H8, H9, H10, J5, J6, J7, J8, J9, J10, K5, K6, K7, K8, K9, K10 | Thermal Ground |

Note: All digital, analog, and thermal grounds are connected together on the package.

Figure 3. S3098 Pinout (Top View)

| | 1 | 2 | 3 | 4 | 5 | 6 | 7 | 8 | 9 | 10 | 11 | 12 | 13 | 14 | |
|-------------------------|---------------|----------------|----------------------------|-------------|-------------------------|----------------|------------------|------------------------|----------------|-------------|---------------|---------------|----------------|---------------|---------|
| A | ANALOG GND | ANALOG GND | ANALOG AVCC +3.3V (FILTER) | ANALOG GND | ANALOG AVCC +3.3V (VCO) | TSTSIG | RSTB | DIGITAL GND | SDLV PECLN | DIGITAL GND | RX622 MCKN | LOCKDET | DIGITAL GND | DIGITAL GND | |
| B | REFCLKP | ANALOG GND | ANALOG GND | CAP1 | ANALOG GND | ANALOG GND | DIGITAL GND | CORE VCC +2.5V | POCLKN | POCLKP | RX622 MCKP | SUB VEE -5.2V | SDLV CMOSN | DIGITAL GND | |
| C | REFCLKN | ANALOG GND | ANALOG GND | CAP2 | ANALOG GND | TESTB | LVCMOS VCC +2.5V | DIGITAL VCC +3.3V (PD) | LVDS VCC +2.5V | DIGITAL GND | | DIGITAL GND | CORE VCC +2.5V | LCKREFN | |
| D | CML VEE -5.2V | ANALOG GND | | | | | | | | | | | SUB VEE -5.2V | DIGITAL GND | |
| E | ANALOG GND | CML VEE -5.2V | | | | | | | | | | | DIGITAL GND | POUT15N | |
| F | ANALOG GND | ANALOG GND | | | | | | | | | | | POUT14N | POUT15P | |
| G | SERDATIP | | | | | | | | | | | | | POUT14P | POUT13N |
| H | ANALOG GND | ANALOG GND | | | | | | | | | | | LVDS VCC +2.5V | POUT13P | |
| J | SERDATIN | | | | | | | | | | | | | SUB VEE -5.2V | POUT12N |
| K | ANALOG GND | ANALOG GND | | | | | | | | | | | POUT11N | POUT12P | |
| L | ANALOG GND | CML VEE -5.2V | | | | | | | | | | | POUT11P | DIGITAL GND | |
| PACKAGE TOP VIEW | | | | | | | | | | | | | | | |
| M | ANALOG GND | CORE VCC +2.5V | LVDS VCC +2.5V | DIGITAL GND | DIGITAL GND | LVDS VCC +2.5V | DIGITAL GND | CORE VCC +2.5V | CORE VCC +2.5V | DIGITAL GND | POUT8P | POUT8N | LVDS VCC +2.5V | POUT10N | |
| N | DIGITAL GND | POUT0P | POUT0N | POUT2P | POUT2N | POUT4P | POUT4N | POUT6P | POUT6N | DIGITAL GND | SUB VEE -5.2V | POUT9P | POUT9N | POUT10P | |
| P | DIGITAL GND | DIGITAL GND | POUT1P | POUT1N | POUT3P | POUT3N | POUT5P | POUT5N | POUT7P | POUT7N | DIGITAL GND | DIGITAL GND | DIGITAL GND | DIGITAL GND | |

Figure 4. Compact 15 mm x 15 mm 148-pin CBGA Package

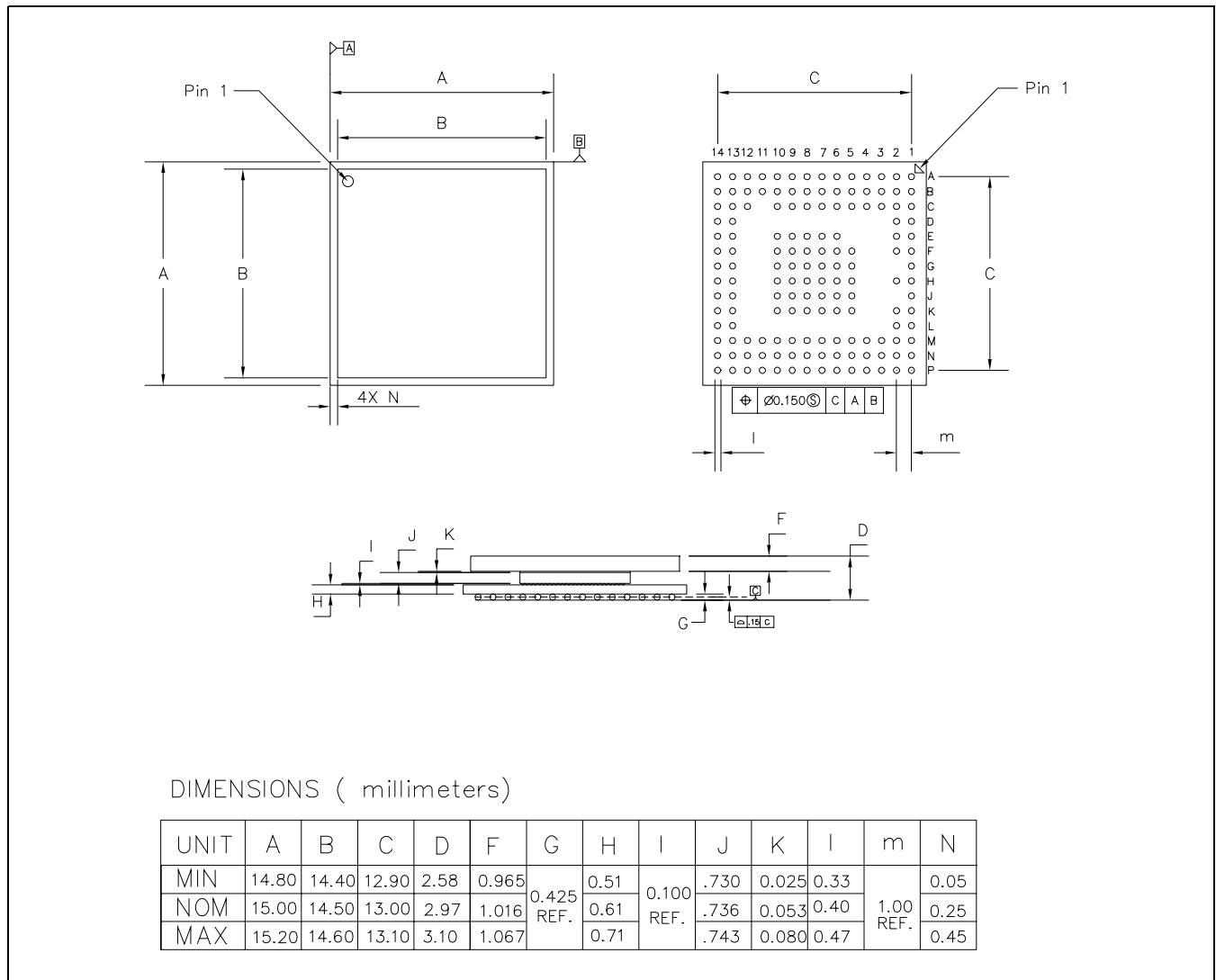

Table 7. Package Thermals

| Max Package Power (85°C Ambient) (Assuming 125°C Junction Temp) | θ_{ja} | θ_{jc} |
|---|---------------|---------------|
| 1.95 W | 20.5°C/Watt | 3.0°C/Watt |

Table 8. Performance Specifications

| Parameter | Min. | Typ | Max | Units | Conditions |
|--|-------|------|--------------------------------|----------|---|
| Nominal VCO Center Frequency | 9.953 | | 10.709 | GHz | |
| 155.52 MHz (or equivalent FEC rate) Reference Clock Frequency Tolerance | -100 | | 100 | ppm | ± 20 ppm is required to meet SONET output frequency specification. |
| 155.52 MHz (or equivalent FEC rate) Reference Clock Input Duty Cycle | 40 | | 60 | % of UI | |
| 155.52 MHz (or equivalent FEC rate) Reference Clock Rise and Fall Times | 0.080 | | 0.8 | ns | 20% to 80% of amplitude. |
| SERDATIP/N Input Return Loss (S_{11}) (when driven differentially) | | | -10 | dB | DC - 10 GHz |
| SERDATIP Input Return Loss (S_{11}) (when driven single-ended using the termination scheme in Figure 13) | | | -5 | dB | DC - 10 GHz |
| Acquisition Lock Time (RSTB deassertion to LOCKDET assertion) | | 4.5 | | ms | Minimum transition density of 50%. Guaranteed, but not tested. With device already powered up and valid REFCLK. |
| Frequency difference at which the PLL goes out-of-lock (REFCLK compared to the divided down VCO clock). | ±440 | ±600 | ±732 | ppm | |
| Frequency difference at which receive PLL goes into lock (REFCLK compared to the divided down VCO clock). | ±220 | ±300 | ±366 | ppm | |
| J_{tol} Jitter Tolerance (SERDATIP/N) | | | 15 | UI (p-p) | 10 Hz-2.4 kHz (Sinusoidal) |
| | | | $15/(f \div 2400)$ | UI (p-p) | 2.4 kHz-24 kHz (Sinusoidal) |
| | | | 1.5 | UI (p-p) | 24 kHz-400 kHz (Sinusoidal) |
| | | | $1.5/(f \div 400 \times 10^3)$ | UI (p-p) | 400 kHz-4 MHz (Sinusoidal) |
| | | | 0.15 | UI (p-p) | 4 MHz-1 GHz (Sinusoidal) |
| L_{cid} Consecutive identical digits at Serial Data Input | | | 80 | bits | Number of bits with no transitions. (SONET spec is 75 bits max.) |

Table 9. Absolute Maximum Ratings

The following are the absolute maximum stress ratings for the S3098 device. Stresses beyond those listed may cause permanent damage to the device. Absolute maximum ratings are stress ratings only, and operation of the device at the maximums stated or any other conditions beyond those indicated in the "Recommended Operating Conditions" of the document are not inferred. Exposure to absolute maximum rating conditions for extended periods may affect device reliability.

| Parameter | Min. | Typ | Max | Units |
|--|-----------------------|-----|----------------------------|-------|
| Storage Temperature | -55 | | 150 | °C |
| V _{CC_2.5V} 2.5 V Supply | -0.5 | | 2.7 | V |
| V _{CC_3.3V} 3.3 V Supply | -0.5 | | 3.6 | V |
| V _{EE} -5.2 V Supply | -7.0 | | -0.5 | V |
| LVC MOS Input Voltage | -0.5 | | V _{CC_2.5V} + 0.5 | V |
| LVPECL Input Voltage | -0.5 | | V _{CC_3.3V} + 0.5 | V |
| CML Input Voltage | V _{EE} -0.25 | | GND | V |
| LVDS Output Current Per Pin | | | 5 | mA |
| LVC MOS Output Current per pin (source/sink) | | | 30/1000 | uA |
| LVC MOS Input Current per pin (source/sink) | | | 200/65 | uA |
| LVDS Input Current Per Pin | | | 7 | mA |
| LVPECL Input Current Per Pin | | | 13 | mA |
| CML Input Current Per Pin | | | 13 | mA |

Electrostatic Discharge (ESD) Ratings

The S3098 is rated to the following ESD voltages based on the human body model per JESD22-A114-B specification:

1. All pins are rated at 100 V.

Table 10. Recommended Operating Conditions

| Parameter | Min. | Typ | Max | Units | Conditions |
|--|-------|------|-------|-------|--|
| Ambient Temperature Under Bias | 0 | | 85 | °C | Over process, voltage and temperature range. |
| Junction Temperature Under Bias | 25 | | 125 | °C | Over process, voltage and temperature range. |
| Voltage on V _{CC_2.5 V} with Respect to GND | 2.375 | 2.5 | 2.625 | V | Over process, voltage and temperature range. |
| Voltage on V _{CC_3.3 V} with Respect to GND | 3.135 | 3.3 | 3.465 | V | Over process, voltage and temperature range. |
| Voltage on V _{EE} with Respect to GND | -4.94 | -5.2 | -5.46 | V | Over process, voltage and temperature range. |
| I _{CC_2.5 V} Supply Current | | | 427 | mA | Outputs terminated. |
| I _{EE_CML} Supply Current | | | 44 | mA | Outputs terminated. |
| I _{CC_3.3 V_AVCC/VCC} Supply Current | | | 105 | mA | Outputs terminated. 60% is AVCC 40% is VCC |
| Power Dissipation | | | 1.72 | W | Outputs terminated. |
| Power Supply Noise Rejection | | 35 | | mVpp | 6 kHz to 2 MHz bandwidth |

Table 11. Internally Biased Differential CML Input DC Characteristics

| Parameter | Description | Min. | Typ | Max | Units | Conditions |
|----------------------|--|------------|-----------|------------|-------|--|
| V _{IH} | Input High Voltage | GND -1.195 | | GND | V | Over process, voltage and temperature range. |
| V _{IL} | Input Low Voltage | GND -1.55 | | GND -0.305 | V | Over process, voltage and temperature range. |
| V _{IDIFF} | Differential Input Voltage Swing | 25 | | 1400 | mV | See Figure 6, <i>Differential Voltage Measurement</i> . |
| V _{ISINGLE} | Single-ended Input Voltage Swing (while driven differentially) | 12.5 | | 700 | mV | See Figure 6, <i>Differential Voltage Measurement</i> . |
| V _{ISINGLE} | Single-ended Input Voltage Swing (while driven single-ended) | 50* | | 700 | mV | See Figure 7, <i>Single-ended Data Input Voltage Measurement</i> . |
| V _{ICM} | Input Common Mode Voltage | GND -1.2 | GND -0.65 | GND -0.3 | V | Over process, voltage and temperature range. |
| R _{IDIFF} | Differential Input Resistance | 70 | | 100 | Ω | Over process, voltage and temperature range. DC measurement. |

* - Consult Single-Ended Termination Recommendation Application Note for improvement of input sensitivity.

Table 12. LVDS Output Characteristics

| Parameter | Description | Min. | Typ | Max | Units | Conditions |
|----------------------|-------------------------------|------|-----|------|-------|--|
| V _{OH} | Output High Voltage | 1.25 | | 1.8 | V | Output loading is 100 Ω line-to-line. Over process, voltage and temperature range. |
| V _{OL} | Output Low Voltage | 0.85 | | 1.45 | V | Output loading is 100 Ω line-to-line. Over process, voltage and temperature range. |
| V _{ODIFF} | Output Differential Voltage | 500 | 740 | 1100 | mV | Output loading is 100 Ω line-to-line. Over process, voltage and temperature range. See Figure 6, <i>Differential Voltage Measurement</i> |
| V _{OSINGLE} | Output Single-ended Voltage | 250 | 370 | 550 | mV | Output loading is 100 Ω line-to-line. Over process, voltage and temperature range. See Figure 6, <i>Differential Voltage Measurement</i> . |
| R _{ODIFF} | Differential Output Impedance | | | 140 | Ω | Over process, voltage and temperature range. Guaranteed by design. |

Table 13. Internally Biased Differential LVPECL Input DC Characteristics (REFCLKP/N)

| Parameter | Description | Min. | Typ | Max | Units | Conditions |
|----------------------|----------------------------------|--------------------------------|-----|--------------------------------|-------|--|
| V _{IH} | Input High Voltage | V _{CC_3.3 V} -1.20 | | V _{CC_3.3 V} -0.50 | V | Over process, voltage and temperature range. |
| V _{IL} | Input Low Voltage | V _{CC_3.3 V} -2.00 | | V _{CC_3.3 V} -1.40 | V | Over process, voltage and temperature range. |
| V _{IDIFF} | Differential Input Voltage Swing | 300 | | 1200 | mV | Over process, voltage and temperature range. See Figure 6, <i>Differential Voltage Measurement</i> |
| V _{ISINGLE} | Single-ended Input Voltage Swing | 150 | | 600 | mV | Over process, voltage and temperature range. See Figure 6, <i>Differential Voltage Measurement</i> |
| V _{ICM} | Input Common Mode Voltage | V _{CC_3.3 V} -1.60 | | V _{CC_3.3 V} -0.95 | V | Over process, voltage and temperature range. |
| R _{IDIFF} | Differential Input Impedance | 80 | 100 | 120 | Ω | Over process, voltage and temperature range. |

Table 14. Single-Ended LVPECL Input DC Characteristics (SDLVPECLN)

| Parameter | Description | Min. | Typ | Max | Units | Conditions |
|-----------------|--------------------|--------------------------------|-----|--------------------------------|-------|--|
| V _{IH} | Input High Voltage | V _{CC_3.3 V} -1.20 | | V _{CC_3.3 V} -0.50 | V | Over process, voltage and temperature range. |
| V _{IL} | Input Low Voltage | V _{CC_3.3 V} -2.00 | | V _{CC_3.3 V} -1.40 | V | Over process, voltage and temperature range. |
| I _{IH} | Input High Current | 50 | | 300 | μA | Over process, voltage and temperature range. V _{IH} = V _{CC_3.3 V} - 0.5 V |
| I _{IL} | Input Low Current | -100 | | 1.5 | μA | Over process, voltage and temperature range. V _{IL} = V _{CC_3.3 V} - 2 V |

Table 15. LVCMOS Input DC Characteristics

| Parameter | Description | Min. | Typ | Max | Units | Conditions |
|-----------------|--------------------|------|-----|-----------------------|-------|--|
| V _{IH} | Input High Voltage | 1.7 | | V _{CC_2.5 V} | V | Over process, voltage and temperature range. |
| V _{IL} | Input Low Voltage | 0 | | 0.7 | V | Over process, voltage and temperature range. |
| I _{IH} | Input High Current | | | 65 | μA | V _{IH} min |
| I _{IL} | Input Low Current | | | 200 | μA | V _{IL} min |

Table 16. LVCMOS Output DC Characteristics

| Parameter | Description | Min. | Typ | Max | Units | Conditions |
|-----------------|---------------------|------|-----|-----------------------|-------|--|
| V _{OH} | Output High Voltage | 2.0 | | V _{CC_2.5 V} | V | Over process, voltage and temperature range. I _{OH} = 30 μA |
| V _{OL} | Output Low Voltage | 0 | | 0.4 | V | Over process, voltage and temperature range. I _{OL} = 1 mA |

Table 17. AC Characteristics

| Parameter | Description | Min. | Typ | Max | Units | Conditions |
|-------------------|---|------|-----|-----------|-------|---|
| C _{DUTY} | POCLKP/N / RX622MCKP/N Duty Cycle | 45 | | 55 | % | Output loading is 100 Ω line-to-line. Over process, voltage and temperature range. |
| T _{pd} | POUTP/N Delay from POCLKP/N | | | 185 | ps | Over process, voltage and temperature range. See Figure 5, <i>Parallel Data Output Delay from POCLK</i> |
| t _{SU} | POCLKP/N to POUTP/N | 525 | | | ps | Over process, voltage and temperature range. See Figure 5, <i>Parallel Data Output Delay from POCLK</i> |
| t _H | POCLKP/N to POUTP/N | 525 | | | ps | Over process, voltage and temperature range. See Figure 5, <i>Parallel Data Output Delay from POCLK</i> |
| t _{trf} | LVPECL Input rise and fall time | 80 | | 800 | ps | Over process, voltage and temperature range. 20% to 80%. |
| | LVDS Output rise and fall time | 80 | | 250 | ps | Over process, voltage and temperature range. 20% to 80%. |
| | LVCMOS Output rise and fall time 5 pF load 15 pF load | | | 50 100 | ns | Over process, voltage and temperature range. 20% to 80%. Guaranteed by design. |
| t _{PW} | RSTB Minimum Pulse Width | 100 | | | ns | Guaranteed by design. |

Table 18. External Loop Filter Components (See Figure 12, External Loop Filter)

| Symbol | Description | Value | Unit |
|---------------------------------|---|-------|------|
| R ₁ , R ₂ | Resistor, Surface Mount, 0402 | 15 | Ω |
| C ₁ | Capacitor, Surface Mount, Non-polarized, 0603 or larger | 1 | μF |

Figure 5. Parallel Data Output Delay from POCLK^{1,2}

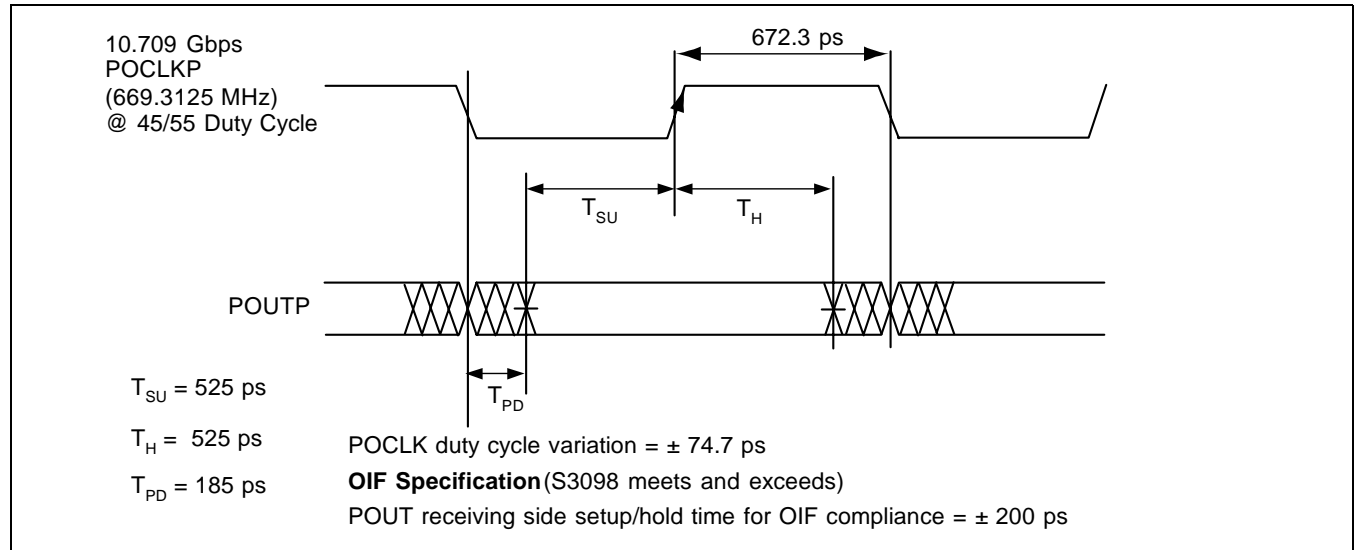

1. When a setup time is specified on LVDS signals between an input and a clock, the setup time in picoseconds, is from the 50% point of the input to the 50% point of the clock.
2. When a hold time is specified on LVDS signals between an input and a clock, the hold time in picoseconds, is from the 50% point of the clock to the 50% point of the input.

Figure 6. Differential Voltage Measurement

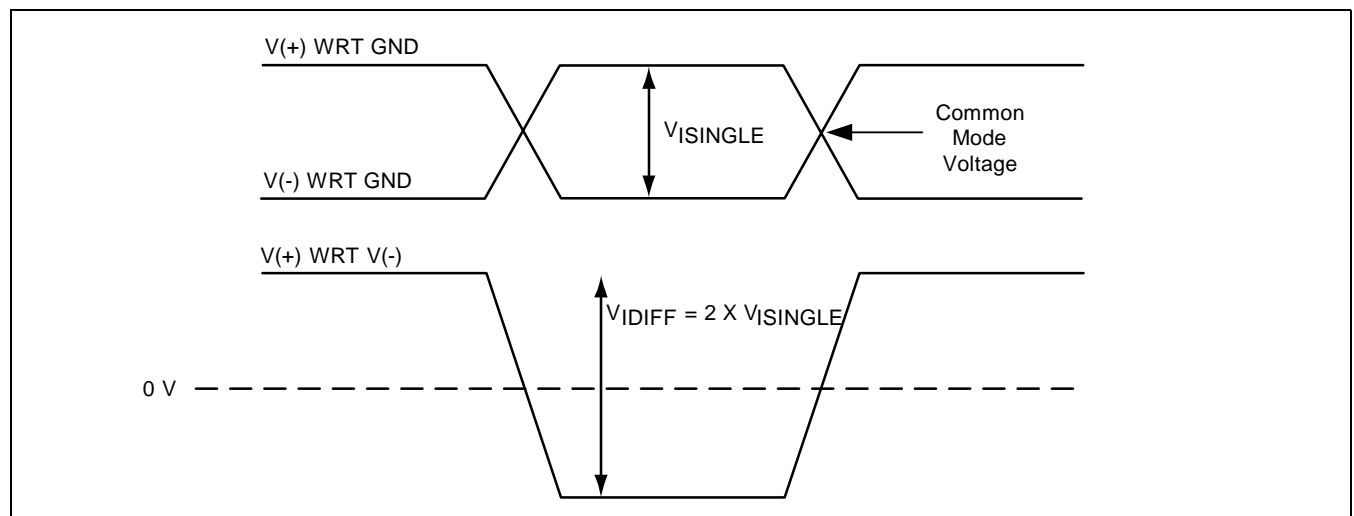

Note: WRT = with respect to.

Figure 7. Single-Ended Data Input Voltage Measurement

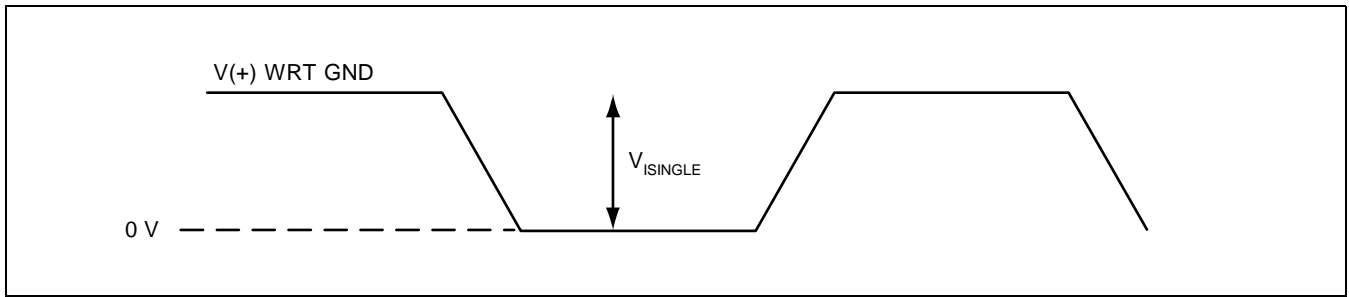

Figure 8. S3098 LVDS Output to LVDS Input

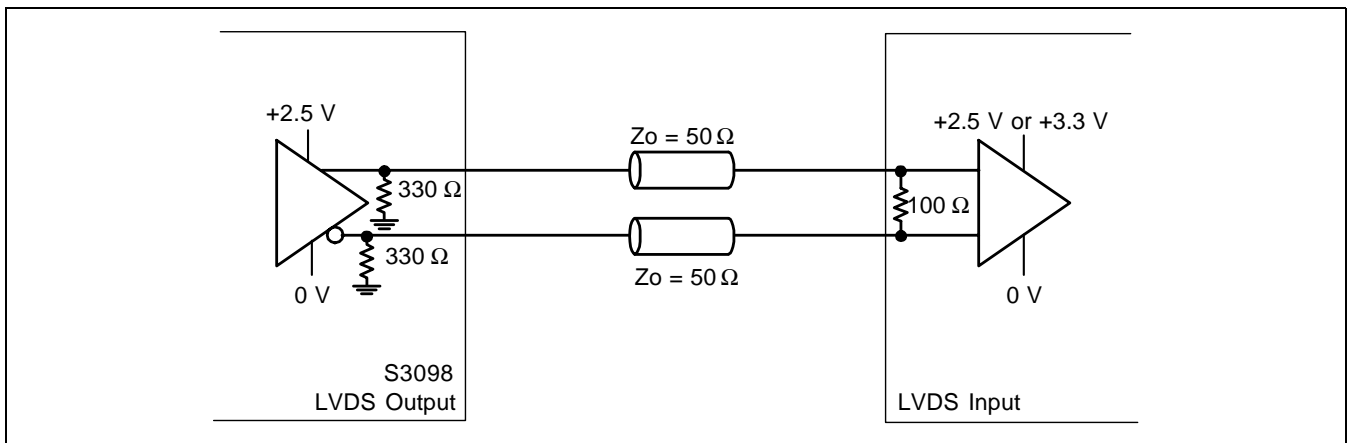

Figure 9. -5.2 V ECL Post Amp to S3098 Input DC Coupled Termination

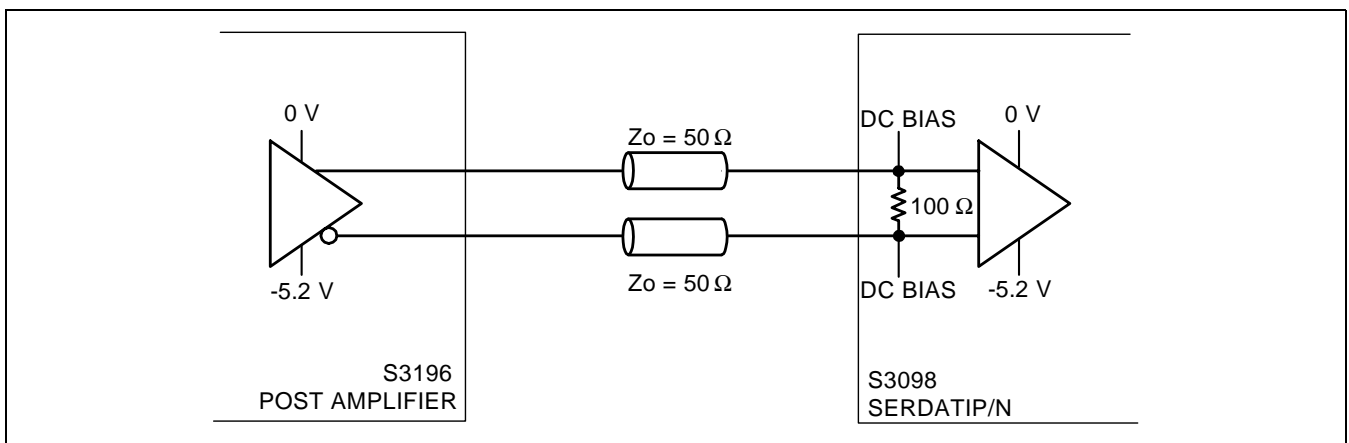

Figure 10. -5.2 V ECL TIA to S3098 DC Coupled Termination

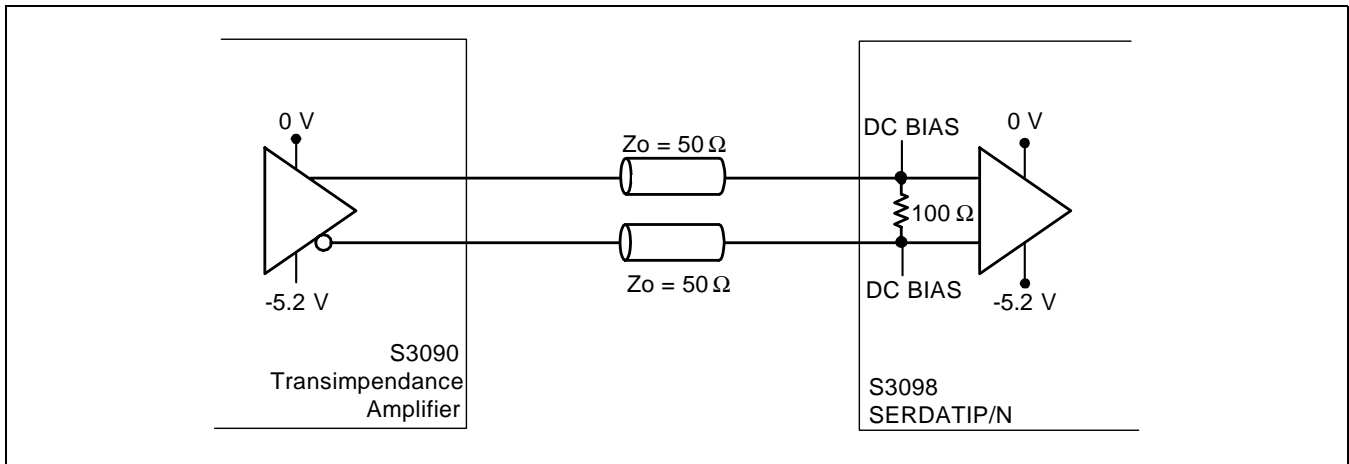

Figure 11. +3.3 V Differential LVPECL Driver to S3098 LVPECL Reference Clock Input, AC Coupled Termination

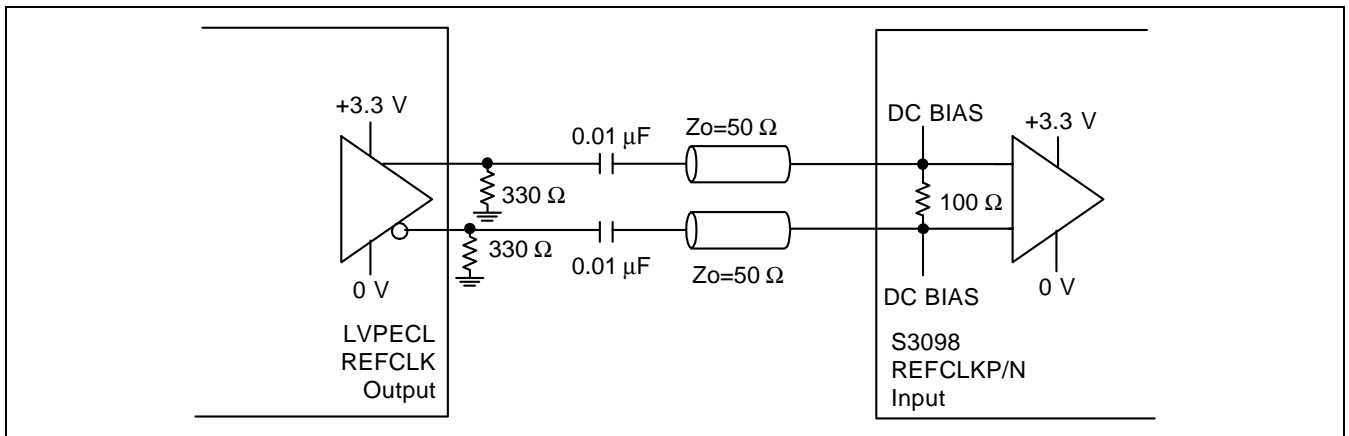

Figure 12. External Loop Filter (See Table 18, External Loop Filter Components)

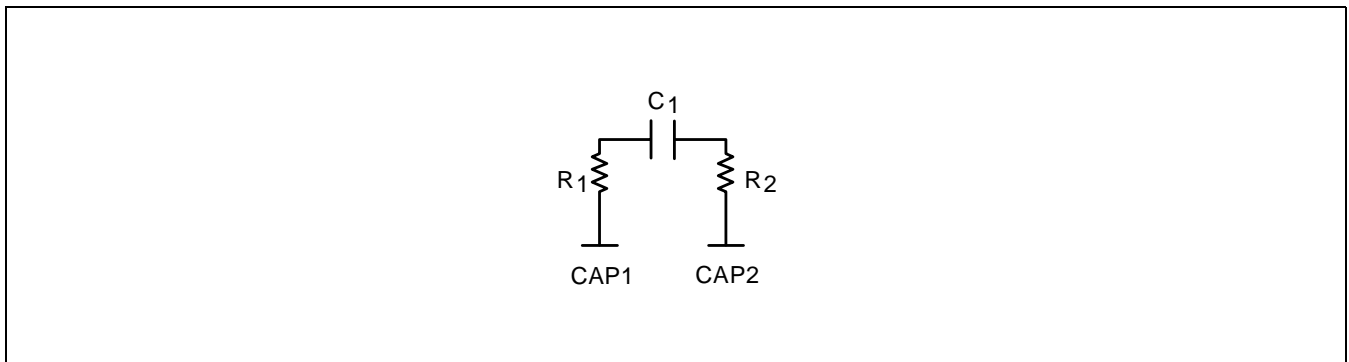
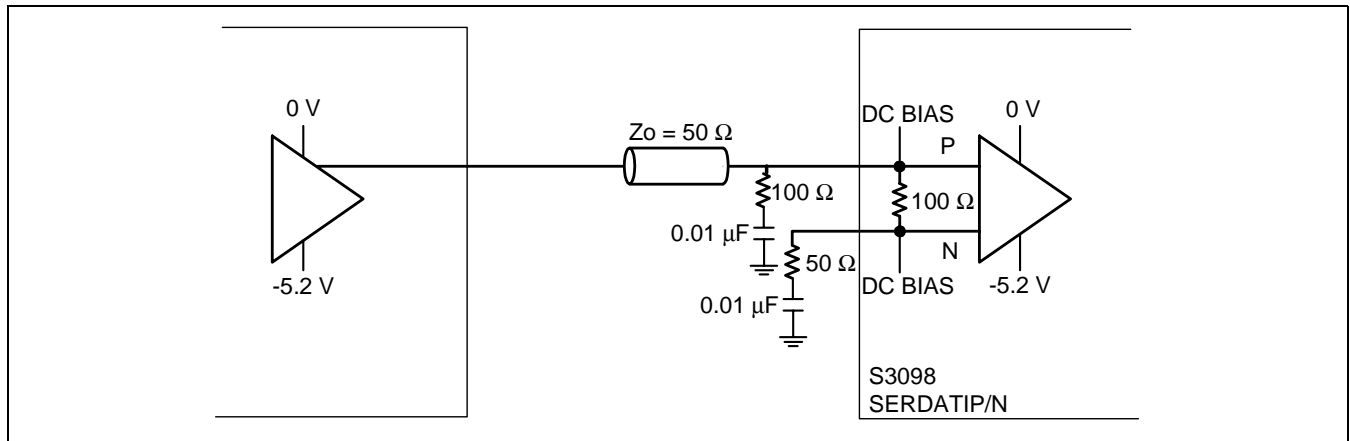

Figure 13. Single-Ended Termination Scheme (Termination Scheme that was characterized)¹



1. See S3098 Single-Ended Termination Recommendation Application Note for more details and improvement of input sensitivity.

Ordering Information

| Prefix | Device | Package | Revision |
|------------------------|--------|---------------|----------|
| S – Integrated Circuit | 3098 | CB – 148 CBGA | 12 |

X
Prefix

XXXX
Device

XX
Package

XX
Revision



Applied Micro Circuits Corporation
6290 Sequence Dr., San Diego, CA 92121

Phone: (858) 450-9333 — (800) 755-2622 — Fax: (858) 450-9885

<http://www.amcc.com>

AMCC reserves the right to make changes to its products or to discontinue any semiconductor product or service without notice, and advises its customers to obtain the latest version of relevant information to verify, before placing orders, that the information being relied on is current.

AMCC does not assume any liability arising out of the application or use of any product or circuit described herein, neither does it convey any license under its patent rights nor the rights of others.

AMCC reserves the right to ship devices of higher grade in place of those of lower grade.

AMCC SEMICONDUCTOR PRODUCTS ARE NOT DESIGNED, INTENDED, AUTHORIZED, OR WARRANTED TO BE SUITABLE FOR USE IN LIFE-SUPPORT APPLICATIONS, DEVICES OR SYSTEMS OR OTHER CRITICAL APPLICATIONS.

AMCC is a registered trademark of Applied Micro Circuits Corporation. Copyright © 2001 Applied Micro Circuits Corporation.

D38/R831