



## 8-bit I<sup>2</sup>C and SMBus I/O Port with Interrupt

### FEATURES

- 400kHz I<sup>2</sup>C bus compatible
- 2.3V to 5.5V operation
- Low stand-by current
- 5V tolerant I/Os
- 8 I/O pins that default to inputs at power-up
- High drive capability
- Individual I/O configuration
- Polarity inversion register
- Active low interrupt output
- Internal power-on reset
- No glitch on power-up
- Noise filter on SDA/SCL inputs
- Cascadable up to 8 devices
- Industrial temperature range
- RoHS-compliant 16-lead SOIC and TSSOP, and 16-pad TQFN (4 x 4mm) packages

### APPLICATIONS

- White goods (dishwashers, washing machines)
- Handheld devices (cell phones, PDAs, digital cameras)
- Data Communications (routers, hubs and servers)

### BLOCK DIAGRAM <sup>(1)</sup>

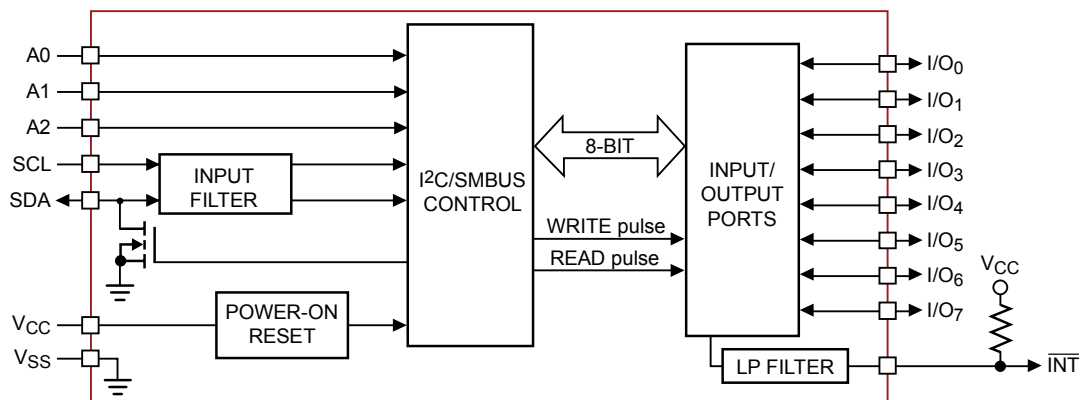

### DESCRIPTION

The CAT9534 is an 8-bit parallel input/output port expander for I<sup>2</sup>C and SMBus compatible applications. These I/O expanders provide a simple solution in applications where additional I/Os are needed: sensors, power switches, LEDs, pushbuttons, and fans.

The CAT9534 consists of an input port register, an output port register, a configuration register, a polarity inversion register and an I<sup>2</sup>C/SMBus-compatible serial interface.

Any of the eight I/Os can be configured as an input or output by writing to the configuration register. The system master can invert the CAT9534 input data by writing to the active-high polarity inversion register.

The CAT9534 features an active low interrupt output which indicates to the system master that an input state has changed.

The device's extended addressing capability allows up to 8 devices to share the same bus.

CAT9534 is offered in 16 pin SOIC, TSSOP and TQFN packages and operates over the full -40°C to +85°C industrial temperature range.

**For Ordering Information details, see page 15.**

**Notes:**

(1) All I/Os are set to inputs at RESET.

## PIN CONFIGURATION

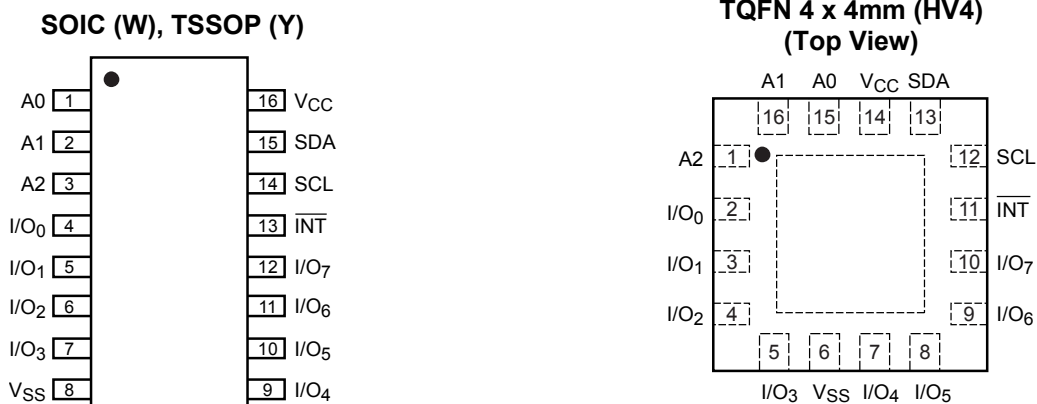

## PIN DESCRIPTION

SOIC / TSSOP	TQFN	Pin Name	Function
1	15	A0	Address Input 0
2	16	A1	Address Input 1
3	1	A2	Address Input 2
4-7	2-5	I/O <sub>0-3</sub>	Input/Output Port 0 to Input/Output Port 3
8	6	V <sub>SS</sub>	Ground
9-12	7-10	I/O <sub>4-7</sub>	Input/Output Port 4 to Input/Output Port 7
13	11	$\overline{\text{INT}}$	Interrupt Output (open drain)
14	12	SCL	Serial Clock
15	13	SDA	Serial Data
16	14	V <sub>CC</sub>	Power Supply

## ABSOLUTE MAXIMUM RATINGS <sup>(1)</sup>

Parameters	Ratings	Units
V <sub>CC</sub> with Respect to Ground	-0.5 to +6.5	V
Voltage on Any Pin with Respect to Ground	-0.5 to +5.5	V
DC Current on I/O <sub>0</sub> to I/O <sub>7</sub>	±50	mA
DC Input Current	±20	mA
V <sub>CC</sub> Supply Current	85	mA
V <sub>SS</sub> Supply Current	100	mA
Package Power Dissipation Capability (T <sub>A</sub> = 25°C)	1.0	W
Junction Temperature	+150	°C
Storage Temperature	-65 to +150	°C

## RELIABILITY CHARACTERISTICS

Symbol	Parameter	Reference Test Method	Min	Units
V <sub>ZAP</sub> <sup>(2)</sup>	ESD Susceptibility	JEDEC Standard JESD 22	2000	Volts
I <sub>LTH</sub> <sup>(2)(3)</sup>	Latch-up	JEDEC Standard 17	100	mA

### Notes:

- Stresses above those listed under "Absolute Maximum Ratings" may cause permanent damage to the device. These are stress ratings only, and functional operation of the device at these or any other conditions outside of those listed in the operational sections of this specification is not implied. Exposure to any absolute maximum rating for extended periods may affect device performance and reliability.
- This parameter is tested initially and after a design or process change that affects the parameter.
- Latch-up protection is provided for stresses up to 100mA on address and data pins from -1V to V<sub>CC</sub> +1V.

## D.C. OPERATING CHARACTERISTICS

$V_{CC} = 2.3$  to  $5.5V$ ;  $T_A = -40^{\circ}C$  to  $+85^{\circ}C$ , unless otherwise specified.

Symbol	Parameter	Conditions	Min	Typ	Max	Unit
<b>Supplies</b>						
$V_{CC}$	Supply voltage		2.3	—	5.5	V
$I_{CC}$	Supply current	Operating mode; $V_{CC} = 5.5V$ ; no load; $f_{SCL} = 100kHz$	—	104	175	$\mu A$
$I_{stbl}$	Standby current	Standby mode; $V_{CC} = 5.5V$ ; no load; $V_I = V_{SS}$ ; $f_{SCL} = 0kHz$ ; I/O = inputs	—	0.25	1	$\mu A$
$I_{stbh}$	Standby current	Standby mode; $V_{CC} = 5.5V$ ; no load; $V_I = V_{CC}$ ; $f_{SCL} = 0kHz$ ; I/O = inputs	—	0.25	1	$\mu A$
$V_{POR}$	Power-on reset voltage	No load; $V_I = V_{CC}$ or $V_{SS}$	—	1.5	1.65	V
<b>SCL, SDA, INT</b>						
$V_{IL}^{(1)}$	Low level input voltage		-0.5	—	$0.3 \times V_{CC}$	V
$V_{IH}^{(1)}$	High level input voltage		$0.7 \times V_{CC}$	—	5.5	V
$I_{OL}$	Low level output current	$V_{OL} = 0.4V$	3	—	—	mA
$I_L$	Leakage current	$V_I = V_{CC}$ or $V_{SS}$	-1	—	+1	$\mu A$
$C_I^{(2)}$	Input capacitance	$V_I = V_{SS}$	—	—	6	pF
$C_O^{(2)}$	Output capacitance	$V_O = V_{SS}$	—	—	8	pF
<b>A0, A1, A2</b>						
$V_{IL}^{(1)}$	Low level input voltage		-0.5	—	0.8	V
$V_{IH}^{(1)}$	High level input voltage		2.0	—	5.5	V
$I_{LI}$	Input leakage current		-1	—	1	$\mu A$
<b>I/Os</b>						
$V_{IL}$	Low level input voltage		-0.5	—	0.8	V
$V_{IH}$	High level input voltage		2.0	—	5.5	V
$I_{OL}$	Low level output current	$V_{OL} = 0.5V$ ; $V_{CC} = 2.3V^{(3)}$	8	10	—	mA
		$V_{OL} = 0.7V$ ; $V_{CC} = 2.3V^{(3)}$	10	13	—	mA
		$V_{OL} = 0.5V$ ; $V_{CC} = 4.5V^{(3)}$	8	17	—	mA
		$V_{OL} = 0.7V$ ; $V_{CC} = 4.5V^{(3)}$	10	24	—	mA
		$V_{OL} = 0.5V$ ; $V_{CC} = 3.0V^{(3)}$	8	14	—	mA
		$V_{OL} = 0.7V$ ; $V_{CC} = 3.0V^{(3)}$	10	19	—	mA
$V_{OH}$	High level output voltage	$I_{OH} = -8mA$ ; $V_{CC} = 2.3V^{(4)}$	1.8	—	—	V
		$I_{OH} = -10mA$ ; $V_{CC} = 2.3V^{(4)}$	1.7	—	—	V
		$I_{OH} = -8mA$ ; $V_{CC} = 3.0V^{(4)}$	2.6	—	—	V
		$I_{OH} = -10mA$ ; $V_{CC} = 3.0V^{(4)}$	2.5	—	—	V
		$I_{OH} = -8mA$ ; $V_{CC} = 4.75V^{(4)}$	4.1	—	—	V
		$I_{OH} = -10mA$ ; $V_{CC} = 4.75V^{(4)}$	4.0	—	—	V
$I_L$	Input leakage current	$V_{CC} = 3.6V$ ; $V_I = V_{CC}$	—	—	1	$\mu A$
$C_I^{(2)}$	Input capacitance		—	—	5	pF
$C_O^{(2)}$	Output capacitance		—	—	8	pF

### Notes:

- (1)  $V_{IL\ min}$  and  $V_{IH\ max}$  are reference values only and are not tested.
- (2) This parameter is characterized initially and after a design or process change that affects the parameter. Not 100% tested.
- (3) The total current sunk by all I/Os must be limited to 100mA and each I/O limited to 25mA maximum.
- (4) The total current sourced by all I/Os must be limited to 85mA.

## A.C. CHARACTERISTICS

$V_{CC} = 2.3$  to  $5.5V$ ;  $T_A = -40^{\circ}C$  to  $+85^{\circ}C$ , unless otherwise specified. <sup>(1)</sup>

Symbol	Parameter	Min	Max	Units
$f_{SCL}$	Clock Frequency		400	kHz
$t_{SP}$	Input Filter Spike Suppression (SDA, SCL)		50	ns
$t_{LOW}$	Clock Low Period	1.3		$\mu s$
$t_{HIGH}$	Clock High Period	0.6		$\mu s$
$t_R^{(2)}$	SDA and SCL Rise Time	20	300	ns
$t_F^{(2)}$	SDA and SCL Fall Time	20	300	ns
$t_{HD:STA}$	Start Condition Hold Time	0.6		$\mu s$
$t_{SU:STA}$	Start Condition Setup Time (for a Repeated Start)	0.6		$\mu s$
$t_{HD:DAT}$	Data Input Hold Time	0		ns
$t_{SU:DAT}$	Data In Setup Time	100		ns
$t_{SU:STO}$	Stop Condition Setup Time	0.6		$\mu s$
$t_{AA}$	SCL Low to Data Out Valid		900	ns
$t_{DH}$	Data Out Hold Time	50		ns
$t_{BUF}^{(2)}$	Time the Bus must be Free Before a New Transmission Can Start	1.3		$\mu s$
<b>Port Timing</b>				
$t_{PV}$	Output Data Valid		200	ns
$t_{PS}$	Input Data Setup Time	100		ns
$t_{PH}$	Input Data Hold Time	1		$\mu s$
<b>Interrupt Timing</b>				
$t_{IV}$	Interrupt Valid		4	$\mu s$
$t_{IR}$	Interrupt Reset		4	$\mu s$

### Notes:

(1) Test conditions according to "AC Test Conditions" table.

(2) This parameter is characterized initially and after a design or process change that affects the parameter. Not 100% tested.

### A.C. TEST CONDITIONS

Input Rise and Fall time	$\leq 10\text{ns}$
CMOS Input Voltages	$0.2V_{CC}$ to $0.8V_{CC}$
CMOS Input Reference Voltages	$0.3V_{CC}$ to $0.7V_{CC}$
TTL Input Voltages	0.4V to 2.4V
TTL Input Reference Voltages	0.8V, 2.0V
Output Reference Voltages	$0.5V_{CC}$
Output Load: SDA, $\overline{\text{INT}}$	Current Source $I_{OL} = 3\text{mA}$ ; $C_L = 100\text{pF}$
Output Load: I/Os	Current Source: $I_{OL}/I_{OH} = 10\text{mA}$ ; $C_L = 50\text{pF}$

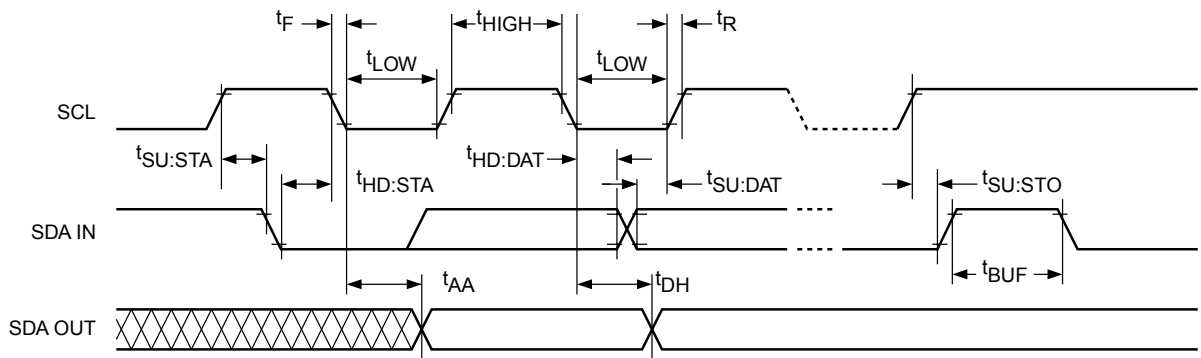

Figure 1. I²C Serial Interface Timing

## PIN DESCRIPTION

### SCL: Serial Clock

The serial clock input clocks all data transferred into or out of the device. The SCL line requires a pull-up resistor if it is driven by an open drain output.

### SDA: Serial Data/Address

The bidirectional serial data/address pin is used to transfer all data into and out of the device. The SDA pin is an open drain output and can be wire-ORed with other open drain or open collector outputs. A pull-up resistor must be connected from SDA line to  $V_{CC}$ . The value of the pull-up resistor,  $R_p$ , can be calculated based on minimum and maximum values from Figure 2 and Figure 3 (see Note).

### A0, A1, A2: Device Address Inputs

These inputs are used for extended addressing capability. The A0, A1, A2 pins should be hardwired to  $V_{CC}$  or  $V_{SS}$ . When hardwired, up to eight CAT9534s may be addressed on a single bus system. The levels on these inputs are compared with corresponding bits, A2, A1, A0, from the slave address byte.

### I/O<sub>0</sub> to I/O<sub>7</sub>: Input / Output Ports

Any of these pins may be configured as input or output. The simplified schematic of I/O<sub>0</sub> to I/O<sub>7</sub> is shown in Figure 4. When an I/O is configured as an input, the Q1 and Q2 output transistors are off creating a high impedance input. If the I/O pin is configured as an output, the push-pull output stage is enabled. Care should be taken if an external voltage is applied to an I/O pin configured as an output due to the low impedance paths that exist between the pin and either  $V_{CC}$  or  $V_{SS}$ .

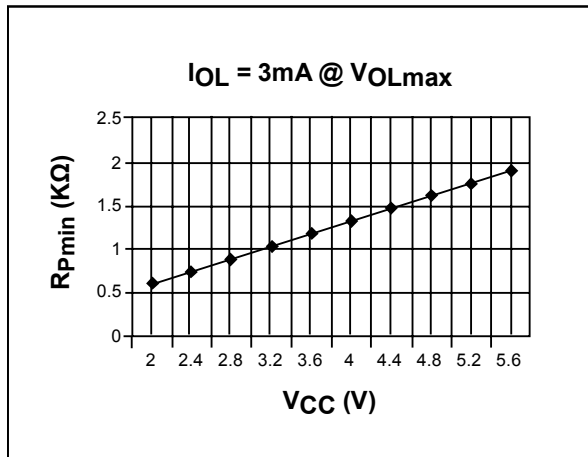

Figure 2. Minimum  $R_p$  Value versus Supply Voltage

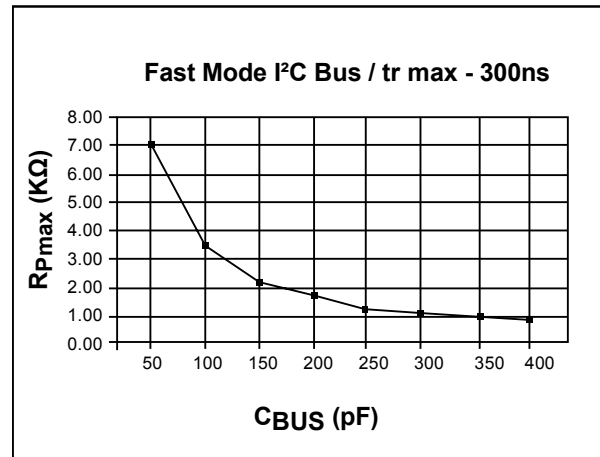

Figure 3. Maximum  $R_p$  Value versus Bus Capacitance

**Note:** According to the Fast Mode I<sup>2</sup>C bus specification, for bus capacitance up to 200pF, the pull up device can be a resistor. For bus loads between 200pF and 400pF, the pull-up device can be a current source ( $I_{max} = 3mA$ ) or a switched resistor circuit.

**INT: Interrupt Output**

The open-drain interrupt output is activated when one of the port pins configured as an input changes state (differs from the corresponding input port register bit state). The interrupt is deactivated when the input

returns to its previous state or the input port register is read. Changing an I/O from an output to an input may cause a false interrupt if the state of the pin does not match the contents of the input port register.

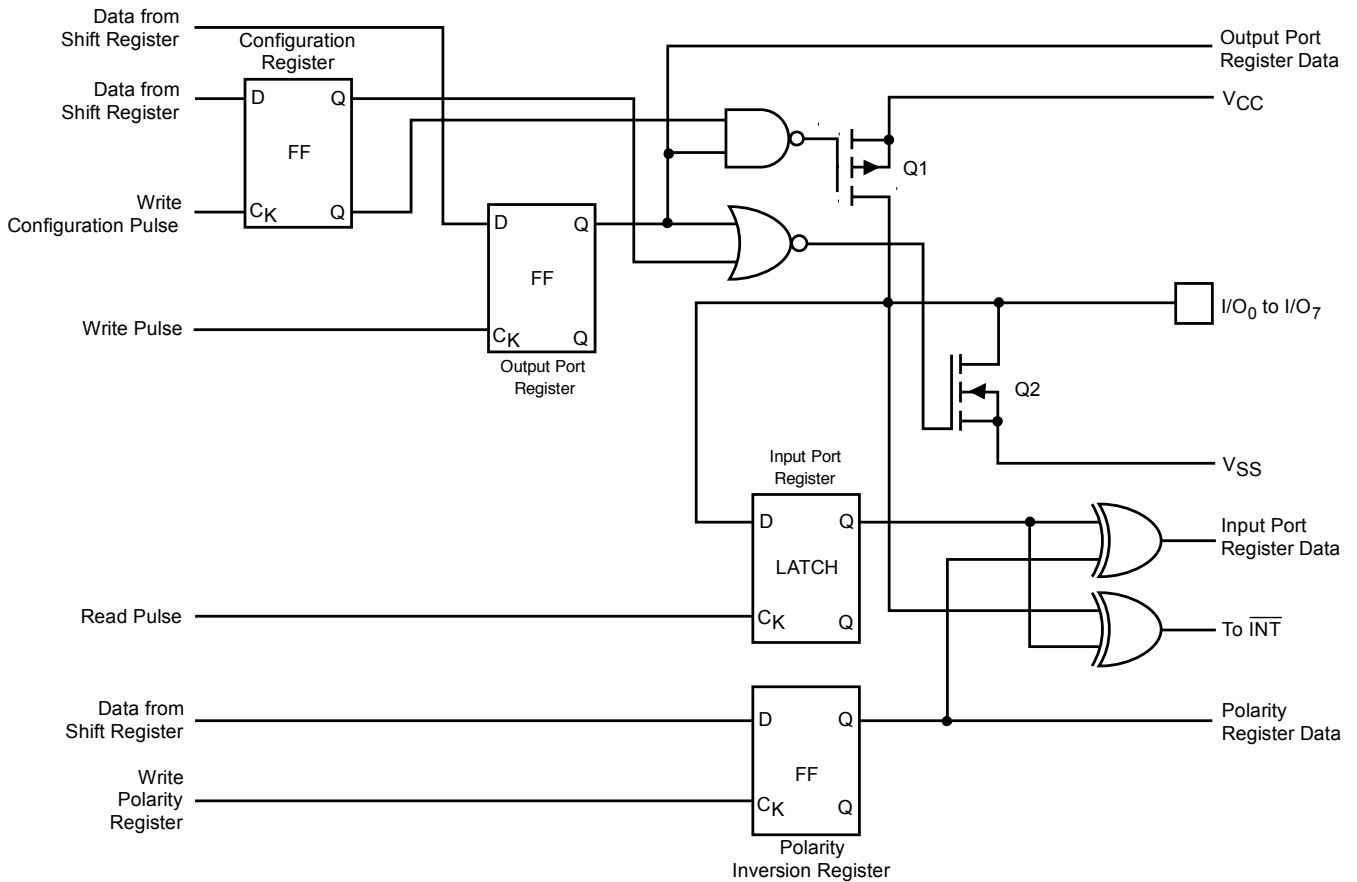

**Figure 4. Simplified Schematic of  $I/O_0$  to  $I/O_7$**

## FUNCTIONAL DESCRIPTION

CAT9534's general purpose input/ output (GPIO) peripherals provide up to eight I/O ports, controlled through an I<sup>2</sup>C compatible serial interface

The CAT9534 supports the I<sup>2</sup>C Bus data transmission protocol. This I<sup>2</sup>C Bus protocol defines any device that sends data to the bus to be a transmitter and any device receiving data to be a receiver. The transfer is controlled by the Master device which generates the serial clock and all START and STOP conditions for bus access. The CAT9534 operates as a Slave device. Both the Master device and Slave device can operate as either transmitter or receiver, but the Master device controls which mode is activated.

### I<sup>2</sup>C BUS PROTOCOL

The features of the I<sup>2</sup>C bus protocol are defined as follows:

- (1) Data transfer may be initiated only when the bus is not busy.
- (2) During a data transfer, the data line must remain stable whenever the clock line is high. Any changes in the data line while the clock line is high will be interpreted as a START or STOP condition (Figure 5).

### START AND STOP CONDITIONS

The START Condition precedes all commands to the device, and is defined as a HIGH to LOW transition of

SDA when SCL is HIGH. The CAT9534 monitors the SDA and SCL lines and will not respond until this condition is met.

A LOW to HIGH transition of SDA when SCL is HIGH determines the STOP condition. All operations must end with a STOP condition.

### DEVICE ADDRESSING

After the bus Master sends a START condition, a slave address byte is required to enable the CAT9534 for a read or write operation. The four most significant bits of the slave address are fixed as binary 0100 and the next three bits are its individual address bits (Figure 6).

The address bits A2, A1 and A0 are used to select which device is accessed from maximum eight devices on the same bus. These bits must compare to their hardwired input pins. The 8th bit following the 7-bit slave address is the R/W bit that specifies whether a read or write operation is to be performed. When this bit is set to "1", a read operation is initiated, and when set to "0", a write operation is selected.

Following the START condition and the slave address byte, the CAT9534 monitors the bus and responds with an acknowledge (on the SDA line) when its address matches the transmitted slave address. The CAT9534 then performs a read or a write operation depending on the state of the R/W bit.

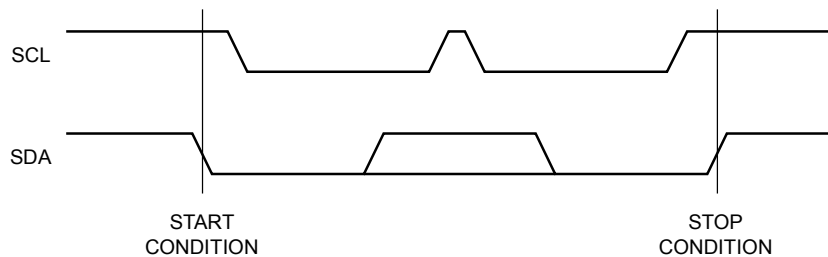

Figure 5. START/STOP Condition

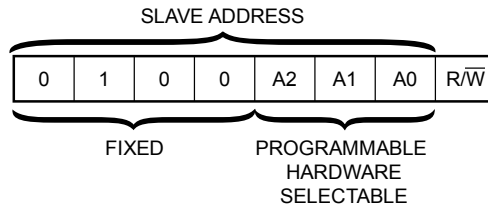

Figure 6. CAT9534 Slave Address



**ACKNOWLEDGE**

After a successful data transfer, each receiving device is required to generate an acknowledge. The acknowledging device pulls down the SDA line during the ninth clock cycle, signaling that it received the 8 bits of data. The SDA line remains stable LOW during the HIGH period of the acknowledge related clock pulse (Figure 5).

The CAT9534 responds with an acknowledge after receiving a START condition and its slave address. If the device has been selected along with a write operation, it responds with an acknowledge after receiving each 8-bit byte.

When the CAT9534 begins a READ mode it transmits 8 bits of data, releases the SDA line, and monitors the line for an acknowledge. Once it receives this acknowledge, the CAT9534 will continue to transmit data. If no acknowledge is sent by the Master, the device terminates data transmission and waits for a STOP condition. The master must then issue a STOP condition to return the CAT9534 to the standby power mode and place the device in a known state.

**REGISTERS AND BUS TRANSACTIONS**

The CAT9534 consists of an input port register, an output port register, a polarity inversion register and a configuration register. Table 1 shows the register address table. Tables 2 to 5 list Register 0 through Register 3 information.

**Table 1. Register Command Byte**

Command (hex)	Protocol	Function
0x00	Read byte	Input port register
0x01	Read/write byte	Output port register
0x02	Read/write byte	Polarity inversion register
0x03	Read/write byte	Configuration register

The command byte is the first byte to follow the device address byte during a write/read bus transaction. The register command byte acts as a pointer to determine which register will be written or read.

The input port register is a read only port. It reflects the incoming logic levels of the I/O pins, regardless of whether the pin is defined as an input or an output by the configuration register. Writes to the input port register are ignored.

**Table 2. Register 0 – Input Port Register**

bit	I <sub>7</sub>	I <sub>6</sub>	I <sub>5</sub>	I <sub>4</sub>	I <sub>3</sub>	I <sub>2</sub>	I <sub>1</sub>	I <sub>0</sub>
default	1	1	1	1	1	1	1	1

**Table 3. Register 1 – Output Port Register**

bit	O <sub>7</sub>	O <sub>6</sub>	O <sub>5</sub>	O <sub>4</sub>	O <sub>3</sub>	O <sub>2</sub>	O <sub>1</sub>	O <sub>0</sub>
default	1	1	1	1	1	1	1	1

**Table 4. Register 2 – Polarity Inversion Register**

bit	N <sub>7</sub>	N <sub>6</sub>	N <sub>5</sub>	N <sub>4</sub>	N <sub>3</sub>	N <sub>2</sub>	N <sub>1</sub>	N <sub>0</sub>
default	0	0	0	0	0	0	0	0

**Table 5. Register 3 – Configuration Register**

bit	C <sub>7</sub>	C <sub>6</sub>	C <sub>5</sub>	C <sub>4</sub>	C <sub>3</sub>	C <sub>2</sub>	C <sub>1</sub>	C <sub>0</sub>
default	1	1	1	1	1	1	1	1

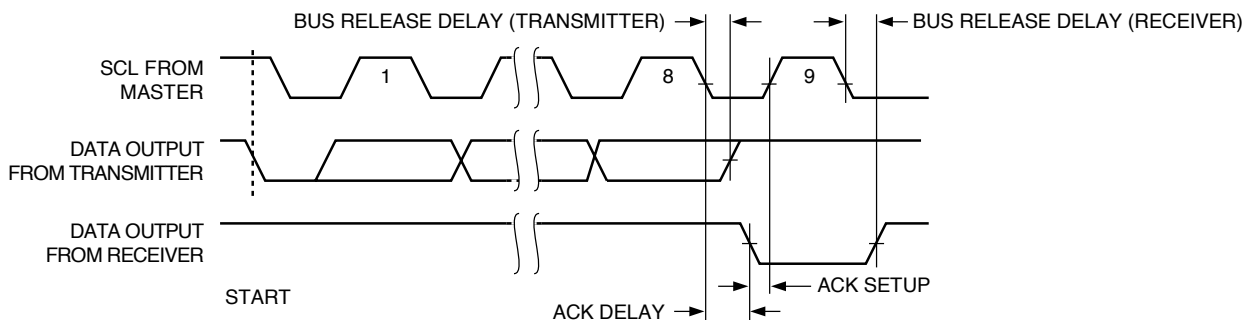

**Figure 7. Acknowledge Timing**

The output port register sets the outgoing logic levels of the I/O ports, defined as outputs by the configuration register. Bit values in this register have no effect on I/O pins defined as inputs. Reads from the output port register reflect the value that is in the flip-flop controlling the output, not the actual I/O pin value.

The polarity inversion register allows the user to invert the polarity of the input port register data. If a bit in this register is set ("1") the corresponding input port data is inverted. If a bit in the polarity inversion register is cleared ("0"), the original input port polarity is retained.

The configuration register sets the directions of the ports. Set the bit in the configuration register to enable

the corresponding port pin as an input with a high impedance output driver. If a bit in this register is cleared, the corresponding port pin is enabled as an output. At power-up, the I/Os are configured as inputs with a weak pull-up resistor to  $V_{CC}$ .

Data is transmitted to the CAT9534's registers using the write mode shown in Figure 8 and Figure 9.

The CAT9534's registers are read according to the timing diagrams shown in Figure 10 and Figure 11. Once a command byte has been sent, the register which was addressed will continue to be accessed by reads until a new command byte will be sent.

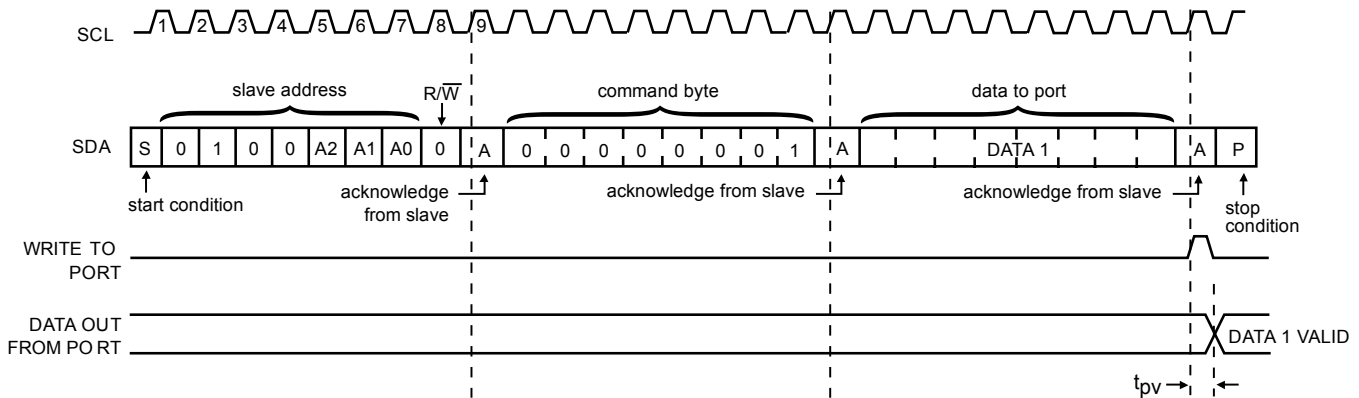

**Figure 8. Write to Output Port Register**

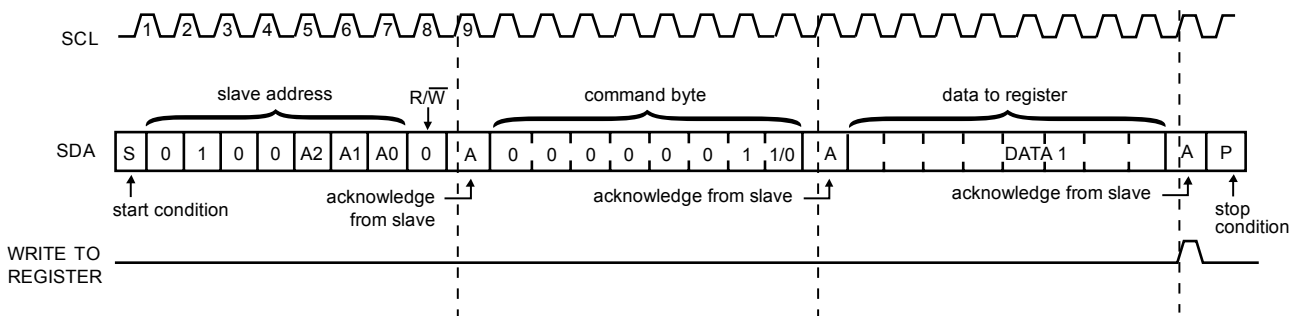

**Figure 9. Write to Configuration or Polarity Inversion Register**

### INTERRUPT OUTPUT

CAT9534's interrupt output is an active LOW open-drain output that is activated when any port pin configured as an input changes state. The interrupt output is reset when the input returns to its previous state or the Input Port Register is read.

Note that changing an I/O from an output to an input may cause a false interrupt to occur if the state of the pin does not match the contents of the Input Port register.

### POWER-ON RESET OPERATION

When the power supply is applied to  $V_{CC}$  pin, an internal power-on reset pulse holds the CAT9534 in a reset state until  $V_{CC}$  reaches  $V_{POR}$  level. At this point, the reset condition is released and the internal state machine and the CAT9534's registers are initialized to their default state.

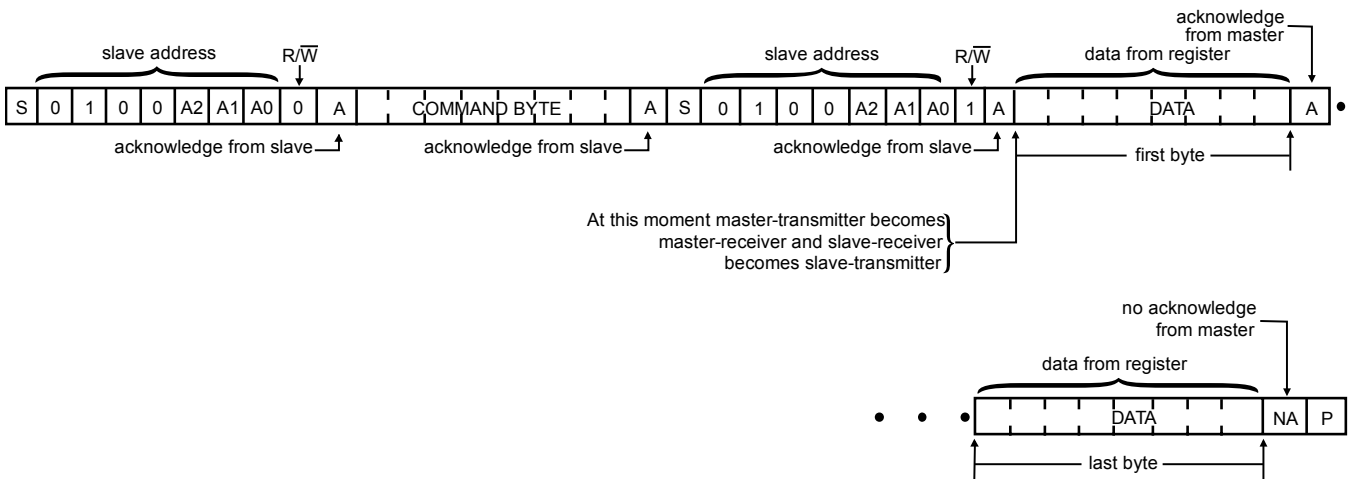

Figure 10. Read from Register

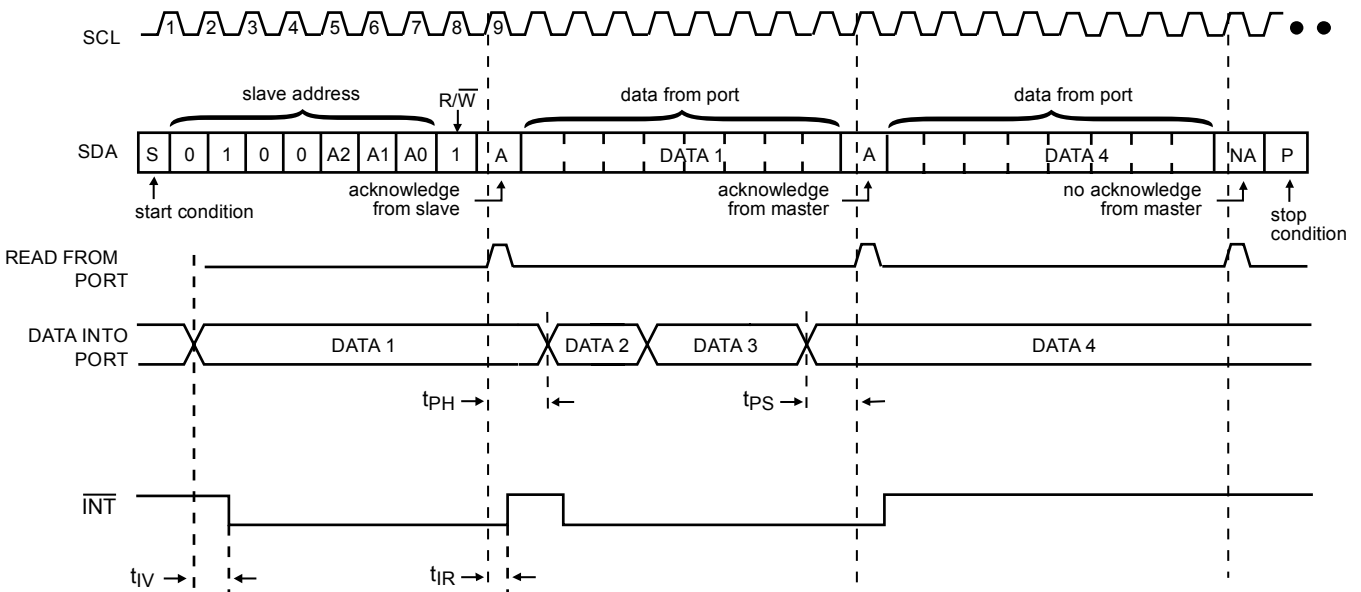
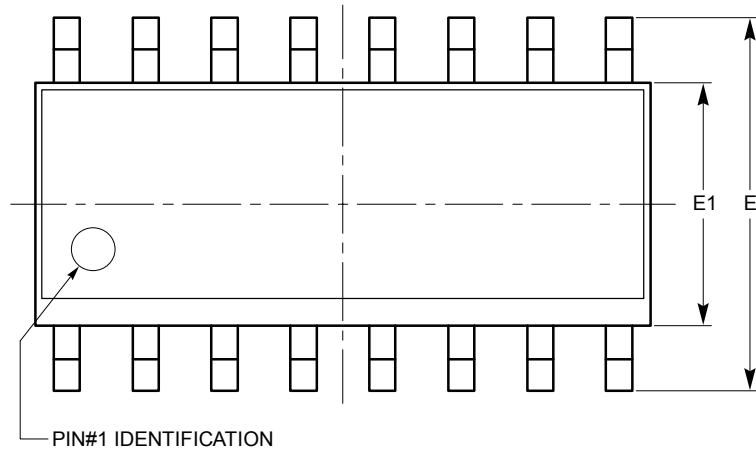

Figure 11. Read Input Port Register

**PACKAGE OUTLINE DRAWINGS**

**SOIC 16-Lead 150mils (W) <sup>(1) (2)</sup>**



SYMBOL	MIN	NOM	MAX
A	1.35		1.75
A1	0.10		0.25
b	0.33		0.51
c	0.19		0.25
D	9.80	9.90	10.00
E	5.80	6.00	6.20
E1	3.80	3.90	4.00
e	1.27 BSC		
h	0.25		0.50
L	0.40		1.27
θ	0°		8°

**TOP VIEW**

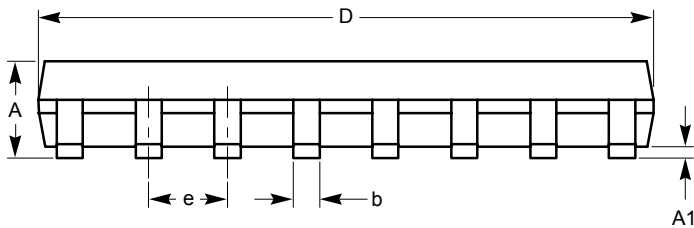

**SIDE VIEW**

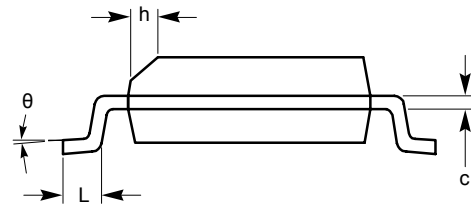

**END VIEW**

**For current Tape and Reel information, download the PDF file from:**  
<http://www.catsemi.com/documents/tapeandreeel.pdf>.

**Notes:**

- (1) All dimensions are in millimeters. Angles in degrees.
- (2) Complies with JEDEC standard MS-012

TSSOP 16-Lead 4.4mm (Y) <sup>(1) (2)</sup>

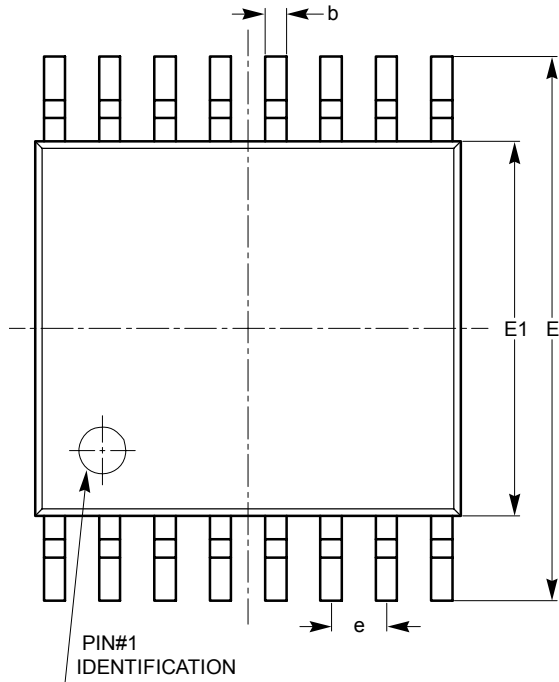

TOP VIEW

SYMBOL	MIN	NOM	MAX
A			1.10
A1	0.05		0.15
A2	0.85		0.95
b	0.19		0.30
c	0.13		0.20
D	4.90		5.10
E	6.30		6.50
E1	4.30		4.50
e	0.65 BSC		
L	1.00 REF		
L1	0.45		0.75
θ1	0°		8°

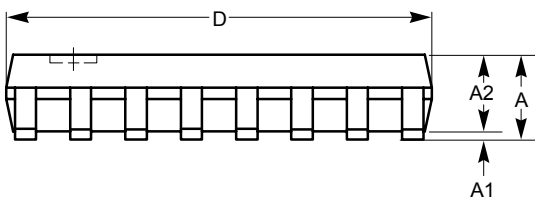

SIDE VIEW

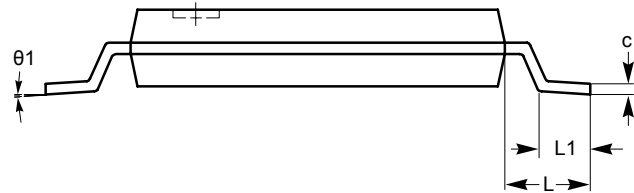

END VIEW

For current Tape and Reel information, download the PDF file from:  
<http://www.catsemi.com/documents/tapeandreel.pdf>.

**Notes:**

- (1) All dimensions are in millimeters. Angles in degrees.
- (2) Complies with JEDEC standard MO-153.

TQFN 16-Pad 4 x 4mm (HV4) <sup>(1) (2)</sup>

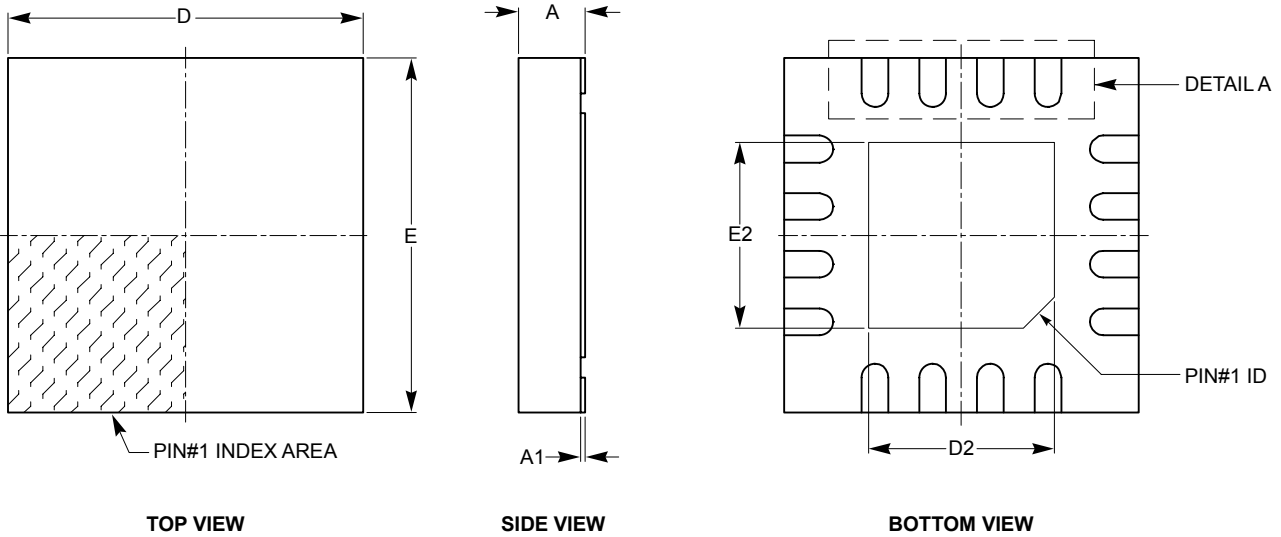

SYMBOL	MIN	NOM	MAX
A	0.70	0.75	0.80
A1	0.00	0.02	0.05
A3	0.20 REF		
b	0.25	0.30	0.35
D	3.90	4.00	4.10
D2	2.00	-	2.25
E	3.90	4.00	4.10
E2	2.00	-	2.25
e	0.65 BSC		
L	0.45	-	0.65

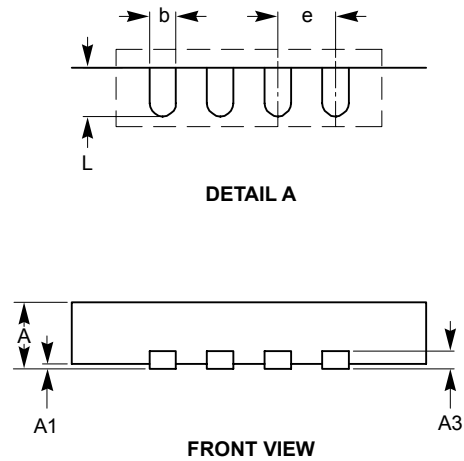

**For current Tape and Reel information, download the PDF file from:  
<http://www.catsemi.com/documents/tapeandreeel.pdf>.**

**Notes:**

- (1) All dimensions are in millimeters.
- (2) Refer to JEDEC standard MO-220.

## EXAMPLE OF ORDERING INFORMATION

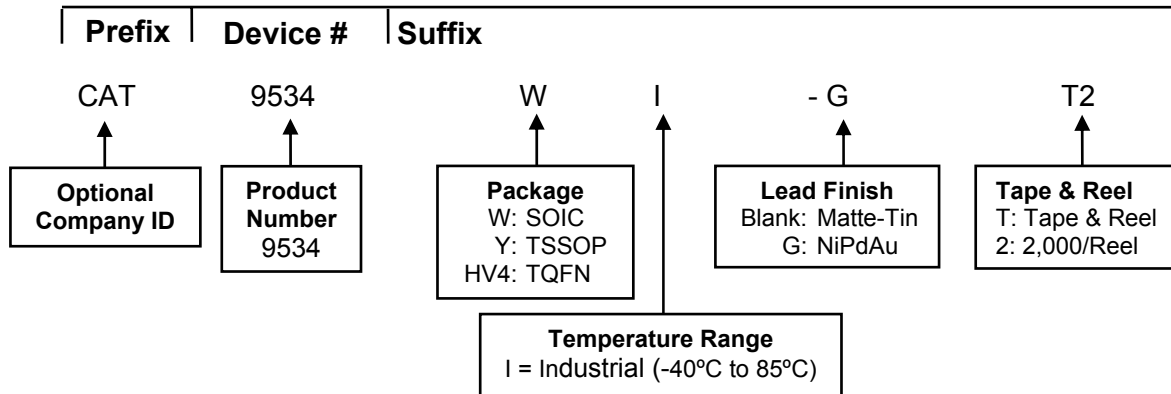

## ORDERING PART NUMBER

Part Number	Package	Lead Finish
CAT9534WI-G	SOIC	NiPdAu
CAT9534WI-GT2	SOIC	NiPdAu
CAT9534YI-G	TSSOP	NiPdAu
CAT9534YI-GT2	TSSOP	NiPdAu
CAT9534HV4I-G	TQFN	NiPdAu
CAT9534HV4I-GT2	TQFN	NiPdAu

**For Product Top Mark Codes, click here:**  
<http://www.catsemi.com/techsupport/producttopmark.asp>

### Notes:

- (1) All packages are RoHS-compliant (Lead-free, Halogen-free).
- (2) The standard lead finish is NiPdAu.
- (3) The device used in the above example is a CAT9534WI-GT2 (SOIC, Industrial Temperature, NiPdAu, Tape & Reel, 2,000/Reel).
- (4) For additional package and temperature options, please contact your nearest Catalyst Semiconductor Sales office.

## REVISION HISTORY

Date	Rev.	Reason
23-May-08	A	Initial Issue

---

### Copyrights, Trademarks and Patents

© Catalyst Semiconductor, Inc.

Trademarks and registered trademarks of Catalyst Semiconductor include each of the following:

Adaptive Analog™, Beyond Memory™, DPP™, EZDim™, LDD™, MiniPot™, Quad-Mode™ and Quantum Charge Programmable™

I<sup>2</sup>C™ is a trademark of Philips Corporation. Catalyst Semiconductor is licensed by Philips Corporation to carry the I<sup>2</sup>C Bus Protocol.

Catalyst Semiconductor has been issued U.S. and foreign patents and has patent applications pending that protect its products.

*CATALYST SEMICONDUCTOR MAKES NO WARRANTY, REPRESENTATION OR GUARANTEE, EXPRESS OR IMPLIED, REGARDING THE SUITABILITY OF ITS PRODUCTS FOR ANY PARTICULAR PURPOSE, NOR THAT THE USE OF ITS PRODUCTS WILL NOT INFRINGE ITS INTELLECTUAL PROPERTY RIGHTS OR THE RIGHTS OF THIRD PARTIES WITH RESPECT TO ANY PARTICULAR USE OR APPLICATION AND SPECIFICALLY DISCLAIMS ANY AND ALL LIABILITY ARISING OUT OF ANY SUCH USE OR APPLICATION, INCLUDING BUT NOT LIMITED TO, CONSEQUENTIAL OR INCIDENTAL DAMAGES.*

Catalyst Semiconductor products are not designed, intended, or authorized for use as components in systems intended for surgical implant into the body, or other applications intended to support or sustain life, or for any other application in which the failure of the Catalyst Semiconductor product could create a situation where personal injury or death may occur.

Catalyst Semiconductor reserves the right to make changes to or discontinue any product or service described herein without notice. Products with data sheets labeled "Advance Information" or "Preliminary" and other products described herein may not be in production or offered for sale.

Catalyst Semiconductor advises customers to obtain the current version of the relevant product information before placing orders. Circuit diagrams illustrate typical semiconductor applications and may not be complete.

---



Catalyst Semiconductor, Inc.  
Corporate Headquarters  
2975 Stender Way  
Santa Clara, CA 95054  
Phone: 408.542.1000  
Fax: 408.542.1200  
www.catsemi.com

Document No: MD-9004  
Revision: A  
Issue date: 05/23/08