

## 9328/DM9328 Dual 8-Bit Shift Register

### General Description

The '9328 is a high speed serial storage element providing 16 bits of storage in the form of two 8-bit registers. The multifunctional capability of this device is provided by several features: 1) additional gating is provided at the input to both

shift registers so that the input is easily multiplexed between two sources; 2) the clock of each register may be provided separately or together; 3) both the true and complementary outputs are provided from each 8-bit register, and both registers may be master cleared from a common input.

### Connection Diagram

Dual-In-Line Package

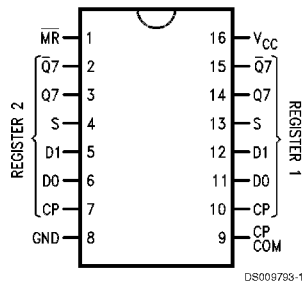

DS009793-1

Order Number 9328DMQB, 9328FMQB or DM9328N  
See Package Number J16A, N16E or W16A

### Logic Symbol

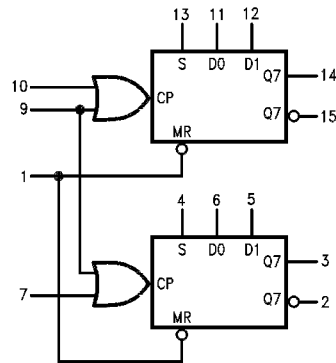

DS009793-2

V<sub>CC</sub> = Pin 16  
GND = Pin 8

Pin Names	Description
S	Data Select Input
D0, D1	Data Inputs
CP	Clock Pulse Input (Active HIGH) Common (Pin 9) Separate (Pins 7 and 10)
$\overline{MR}$	Master Reset Input (Active LOW)
Q7	Last Stage Output
$\overline{Q7}$	Complementary Output

## Absolute Maximum Ratings (Note 1)

Supply Voltage	7V	Military	-55°C to +125°C
Input Voltage	5.5V	Commercial	0°C to +70°C
Operating Free Air Temperature Range		Storage Temperature Range	-65°C to +150°C

## Recommended Operating Conditions

Symbol	Parameter	Military			Commercial			Units
		Min	Nom	Max	Min	Nom	Max	
V <sub>CC</sub>	Supply Voltage	4.5	5	5.5	4.75	5	5.25	V
V <sub>IH</sub>	High Level Input Voltage	2			2			V
V <sub>IL</sub>	Low Level Input Voltage			0.8			0.8	V
I <sub>OH</sub>	High Level Output Current			-0.4			-0.4	mA
I <sub>OL</sub>	Low Level Output Current			16			16	mA
T <sub>A</sub>	Free Air Operating Temperature	-55		125	0		70	°C
t <sub>s</sub> (H)	Setup Time HIGH or LOW	20			20			ns
t <sub>s</sub> (L)	D <sub>n</sub> to CP	20			20			ns
t <sub>h</sub> (H)	Hold Time HIGH or LOW	0			0			ns
t <sub>h</sub> (L)	D <sub>n</sub> to CP	0			0			ns
t <sub>w</sub> (H)	Clock Pulse Width HIGH	25			25			ns
t <sub>w</sub> (L)	or LOW	25			25			ns
t <sub>w</sub> (L)	MR Pulse Width with CP HIGH	30			30			ns
t <sub>w</sub> (L)	MR Pulse Width with CP LOW	40			40			ns
t <sub>rec</sub>	Recovery Time MR to CP	33			33			ns

**Note 1:** The "Absolute Maximum Ratings" are those values beyond which the safety of the device cannot be guaranteed. The device should not be operated at these limits. The parametric values defined in the "Electrical Characteristics" table are not guaranteed at the absolute maximum ratings. The "Recommended Operating Conditions" table will define the conditions for actual device operation.

## Electrical Characteristics

Over Recommended Operating Free Air Temperature Range (Unless Otherwise Noted)

Symbol	Parameter	Conditions	Min	Typ (Note 2)	Max	Units
V <sub>I</sub>	Input Clamp Voltage	V <sub>CC</sub> = Min, I <sub>I</sub> = -12 mA			-1.5	V
V <sub>OH</sub>	High Level Output Voltage	V <sub>CC</sub> = Min, I <sub>OH</sub> = Max V <sub>IL</sub> = Max	2.4	3.4		V
V <sub>OL</sub>	Low Level Output Voltage	V <sub>CC</sub> = Min, I <sub>OL</sub> = Max V <sub>IH</sub> = Min		0.2	0.4	V
I <sub>I</sub>	Input Current @ Max Input Voltage	V <sub>CC</sub> = Max, V <sub>I</sub> = 5.5V			1	mA
I <sub>IH</sub>	High Level Input Current	V <sub>CC</sub> = Max, V <sub>I</sub> = 2.4V MR, D <sub>n</sub> Inputs			40	μA
		CP Inputs			60	
		S Inputs			80	
		CP (COM) Inputs			120	
I <sub>IL</sub>	Low Level Input Current	V <sub>CC</sub> = Max, V <sub>I</sub> = 0.4V MR, D <sub>n</sub> Inputs			-1.6	mA
		CP Inputs			-2.4	
		S Inputs			-3.2	
		CP (COM) Input			-4.8	

## Electrical Characteristics

Over Recommended Operating Free Air Temperature Range (Unless Otherwise Noted) (Continued)

Symbol	Parameter	Conditions		Min	Typ (Note 2)	Max	Units
I <sub>OS</sub>	Short Circuit Output Current	V <sub>CC</sub> = Max (Note 3)	MIL	-20		-70	mA
			COMM	-20		-70	
I <sub>CC</sub>	Supply Current	V <sub>CC</sub> = Max				77	mA

Note 2: All typicals are at V<sub>CC</sub> = 5V, T<sub>A</sub> = 25°C.

Note 3: Not more than one output should be shorted at a time.

## Switching Characteristics

V<sub>CC</sub> = +5.0V, T<sub>A</sub> = +25°C (See Section 1 for waveforms and load configurations)

Symbol	Parameter	C <sub>L</sub> = 15 pF R <sub>L</sub> = 400Ω		Units
		Min	Max	
f <sub>max</sub>	Maximum Shift Right Frequency	20		MHz
t <sub>PLH</sub>	Propagation Delay CP to Q7 or $\overline{Q7}$		20	ns
t <sub>PHL</sub>	Propagation Delay $\overline{MR}$ to Q7		50	ns

## Functional Description

The two 8-bit shift registers have a common clock input (pin 9) and separate clock inputs (pins 10 and 7). The clocking of each register is controlled by the OR function of the separate and the common clock input. Each register is composed of eight clocked RS master/slave flip-flops and a number of gates. The clock OR gate drives the eight clock inputs of the flip-flops in parallel. When the two clock inputs (the separate and the common) to the OR gate are LOW, the slave latches are steady, but data can enter the master latches via the R and S input. During the first LOW-to-HIGH transition of either, or both simultaneously, of the two clock inputs, the data inputs (R and S) are inhibited so that a later change in input data will not affect the master; then the now trapped information in the master is transferred to the slave. When the transfer is complete, both the master and the slave are steady as long as either or both clock inputs remain HIGH. During the HIGH-to-LOW transition of the last remaining HIGH clock input, the transfer path from master to slave is inhibited first, leaving the slave steady in its present state. The data inputs (R and S) are enabled so that new data can enter the master. Either of the clock inputs can be used as clock inhibit inputs by applying a logic HIGH signal. Each 8-bit shift register

has a 2-input multiplexer in front of the serial data input. The two data inputs D0 and D1 are controlled by the data select input (S) following the Boolean expression:

Serial data in: S<sub>D</sub> = SD0 + SD1

An asynchronous master reset is provided which, when activated by a LOW logic level, will clear all 16 stages independently of any other input signal.

### Shift Select Table

INPUTS			OUTPUT
S	D0	D1	Q7 (t <sub>n</sub> + 8)
L	L	X	L
L	H	X	H
H	X	L	L
H	X	H	H

H = HIGH Voltage Level

L = LOW Voltage Level

X = Immaterial

n + 8 = indicates state after eight clock pulse

# Logic Diagram

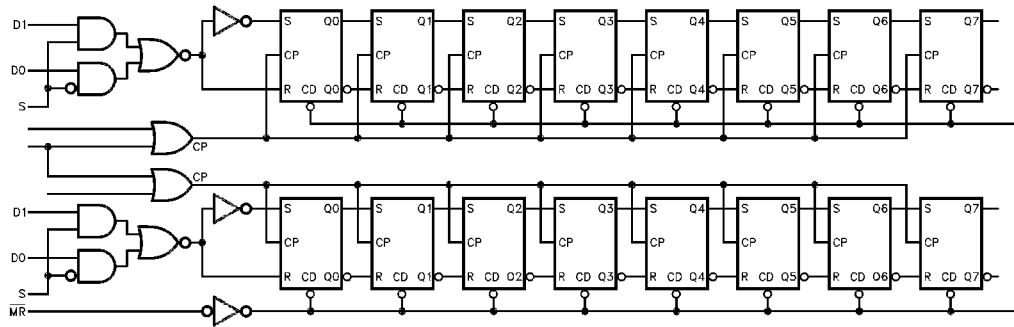

DS009793-3

**Physical Dimensions** inches (millimeters) unless otherwise noted

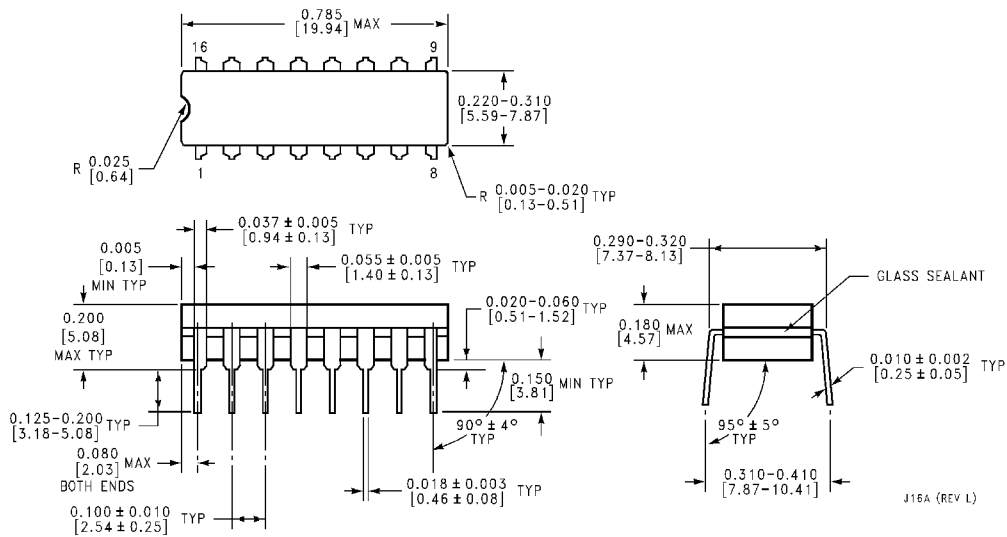

**16-Lead Ceramic Dual-In-Line Package (J)**  
**Order Number 9328DMQB**  
**Package Number J16A**

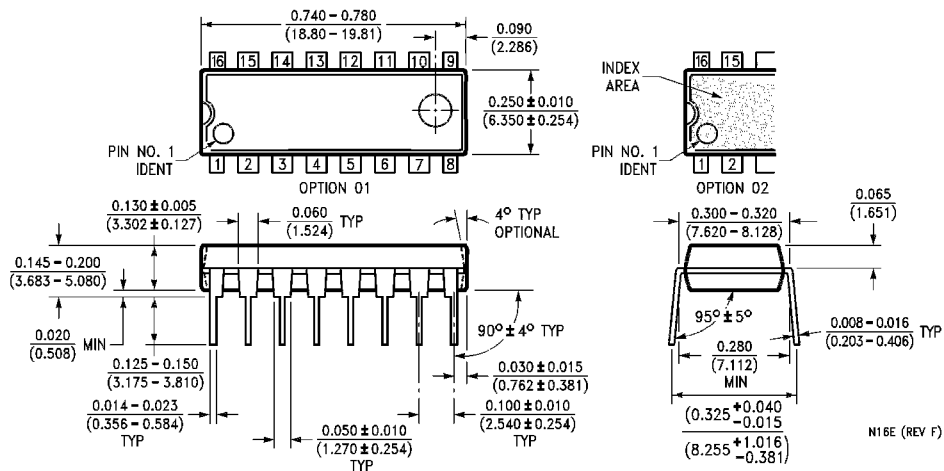

**16-Lead Molded Dual-In-Line Package (N)**  
**Order Number DM9328N**  
**Package Number N16E**

**Physical Dimensions** inches (millimeters) unless otherwise noted (Continued)

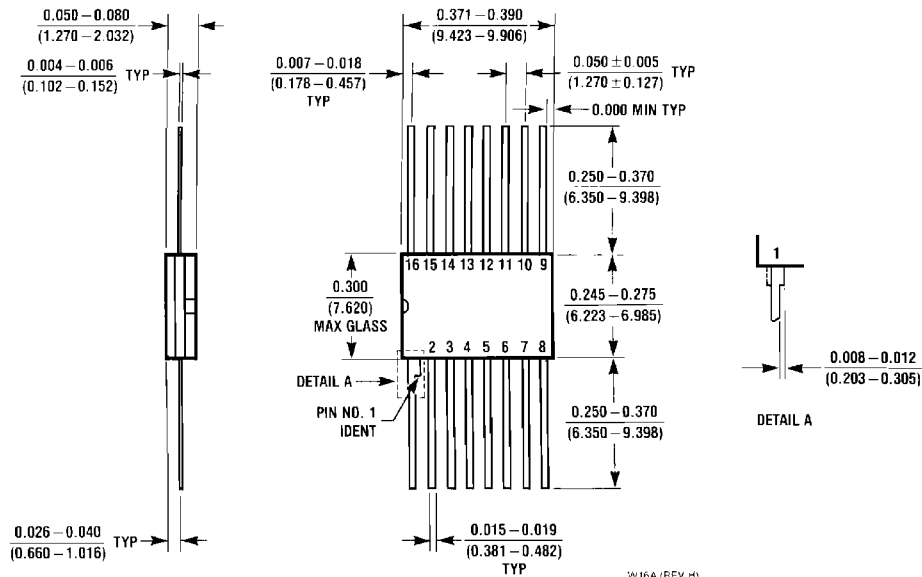

**16-Lead Ceramic Flat Package (W)**  
**Order Number 9328FMQB**  
**Package Number W16A**

W16A (REV H)

**LIFE SUPPORT POLICY**

FAIRCHILD'S PRODUCTS ARE NOT AUTHORIZED FOR USE AS CRITICAL COMPONENTS IN LIFE SUPPORT DEVICES OR SYSTEMS WITHOUT THE EXPRESS WRITTEN APPROVAL OF THE PRESIDENT OF FAIRCHILD SEMICONDUCTOR CORPORATION. As used herein:

1. Life support devices or systems are devices or systems which, (a) are intended for surgical implant into the body, or (b) support or sustain life, and (c) whose failure to perform when properly used in accordance with instructions for use provided in the labeling, can be reasonably expected to result in a significant injury to the user.
2. A critical component in any component of a life support device or system whose failure to perform can be reasonably expected to cause the failure of the life support device or system, or to affect its safety or effectiveness.

**Fairchild Semiconductor Corporation Americas**  
 Customer Response Center  
 Tel: 1-888-522-5372

**Fairchild Semiconductor Europe**  
 Fax: +49 (0) 1 80-530 85 86  
 Email: europe.support@nsc.com  
 Deutsch Tel: +49 (0) 8 141-35-0  
 English Tel: +44 (0) 1 793-85-68-56  
 Italy Tel: +39 (0) 2 57 5631

**Fairchild Semiconductor Hong Kong Ltd.**  
 13th Floor, Straight Block,  
 Ocean Centre, 5 Canton Rd.  
 Tsimshatsui, Kowloon  
 Hong Kong  
 Tel: +852 2737-7200  
 Fax: +852 2314-0061

**National Semiconductor Japan Ltd.**  
 Tel: 81-3-5620-6175  
 Fax: 81-3-5620-6179

[www.fairchildsemi.com](http://www.fairchildsemi.com)