

SNx4HC165 8-Bit Parallel-Load Shift Registers

1 Features

- Wide Operating Voltage Range of 2 V to 6 V
- Outputs Can Drive Up to 10 LSTTL Loads
- Low Power Consumption, 80- μ A Maximum I_{CC}
- Typical $t_{pd} = 13$ ns
- ± 4 -mA Output Drive at 5 V
- Low Input Current of 1 μ A Maximum
- Complementary Outputs
- Direct Overriding Load (Data) Inputs
- Gated Clock Inputs
- Parallel-to-Serial Data Conversion
- On Products Compliant to MIL-PRF-38535, All Parameters Are Tested Unless Otherwise Noted. On All Other Products, Production Processing Does Not Necessarily Include Testing of All Parameters.

2 Applications

- Programmable Logic Controllers
- Appliances
- Video Display Systems
- Output Expander
- Keyboards

3 Description

The SNx4HC165 devices are 8-bit parallel-load shift registers that, when clocked, shift the data toward a serial (Q_H) output. Parallel-in access to each stage is provided by eight individual direct data (A–H) inputs that are enabled by a low level at the shift/load (SH/LD) input. The SNx4HC165 devices also feature a clock-inhibit (CLK INH) function and a complementary serial (\bar{Q}_H) output.

Clocking is accomplished by a low-to-high transition of the clock (CLK) input while SH/LD is held high and CLK INH is held low. The functions of CLK and CLK INH are interchangeable. Because a low CLK and a low-to-high transition of CLK INH also accomplish clocking, CLK INH must be changed to the high level only while CLK is high. Parallel loading is inhibited when SH/LD is held high. While SH/LD is low, the parallel inputs to the register are enabled independently of the levels of the CLK, CLK INH, or serial (SER) inputs.

Device Information⁽¹⁾

PART NUMBER	PACKAGE	BODY SIZE (NOM)
SN74HC165D	SOIC (16)	10.00 mm × 6.20 mm
SN74HC165DB	SSOP (16)	8.20 mm × 6.50 mm
SN74HC165N	PDIP (16)	6.60 mm × 18.92 mm
SN74HC165NS	SO (16)	8.20 mm × 9.90 mm
SN74HC165PW	TSSOP (16)	6.60 mm × 5.10 mm
SN54HC165FK	LCCC (20)	9.09 mm × 9.09 mm
SN54HC165J	CDIP (16)	21.34 mm × 7.52 mm
SN54HC165W	CFP (16)	9.40 mm × 7.75 mm

(1) For all available packages, see the orderable addendum at the end of the data sheet.

Logic Diagram Positive Logic

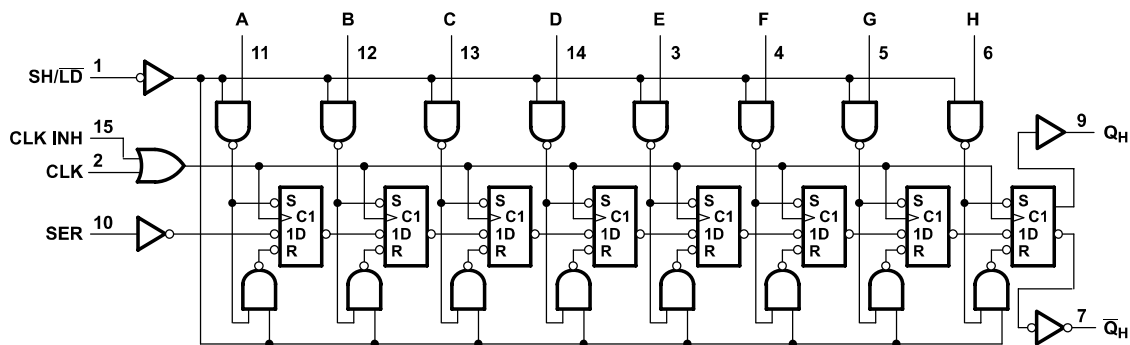

Pin numbers shown are for the D, DB, J, N, NS, PW and W packages.



An IMPORTANT NOTICE at the end of this data sheet addresses availability, warranty, changes, use in safety-critical applications, intellectual property matters and other important disclaimers. PRODUCTION DATA.

Table of Contents

1 Features	1	7 Parameter Measurement Information	11
2 Applications	1	8 Detailed Description	12
3 Description	1	8.1 Overview	12
4 Revision History	2	8.2 Functional Block Diagram	12
5 Pin Configuration and Functions	3	8.3 Feature Description.....	13
6 Specifications	4	8.4 Device Functional Table	13
6.1 Absolute Maximum Ratings	4	9 Application and Implementation	14
6.2 ESD Ratings	4	9.1 Application Information.....	14
6.3 Recommended Operating Conditions.....	4	9.2 Typical Application	14
6.4 Thermal Information.....	4	10 Power Supply Recommendations	15
6.5 Electrical Characteristics, $T_A = 25^\circ\text{C}$	5	11 Layout	15
6.6 Electrical Characteristics, SN54HC165	5	11.1 Layout Guidelines	15
6.7 Electrical Characteristics, SN74HC165	5	11.2 Layout Example	15
6.8 Switching Characteristics, $T_A = 25^\circ\text{C}$	6	12 Device and Documentation Support	16
6.9 Switching Characteristics, SN54HC165.....	6	12.1 Documentation Support	16
6.10 Switching Characteristics, SN74HC165.....	7	12.2 Related Links	16
6.11 Timing Requirements, $T_A = 25^\circ\text{C}$	7	12.3 Community Resources.....	16
6.12 Timing Requirements, SN54HC165.....	8	12.4 Trademarks	16
6.13 Timing Requirements, SN74HC165	9	12.5 Electrostatic Discharge Caution	16
6.14 Operating Characteristics.....	10	12.6 Glossary.....	16
6.15 Typical Characteristics.....	11	13 Mechanical, Packaging, and Orderable Information	16

4 Revision History

NOTE: Page numbers for previous revisions may differ from page numbers in the current version.

Changes from Revision G (August 2013) to Revision H

Page

• Added <i>Applications</i> section, <i>Device Information</i> table, <i>Pin Configuration and Functions</i> section, <i>ESD Ratings</i> table, <i>Feature Description</i> section, <i>Device Functional Modes</i> , <i>Application and Implementation</i> section, <i>Power Supply Recommendations</i> section, <i>Layout</i> section, <i>Device and Documentation Support</i> section, and <i>Mechanical, Packaging, and Orderable Information</i> section	1
• Added Military Disclaimer to <i>Features</i> list.	1
• Added ESD warning.	16

Changes from Revision F (December 2010) to Revision G

Page

• Updated document to new TI data sheet format - no specification changes.	1
• Removed <i>Ordering Information</i> table.	1
• Added Handling Ratings table.	4
• Extended maximum temperature operating range from 85°C to 125°C	4

5 Pin Configuration and Functions

D, DB, N, NS, J, W, or PW Package
16-Pin SOIC, SSOP, PDIP, SO, CDIP, CFP, or TSSOP
Top View

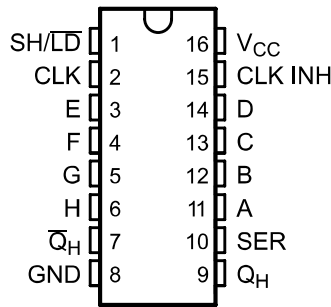

FK Package
20-Pin LCCC
Top View

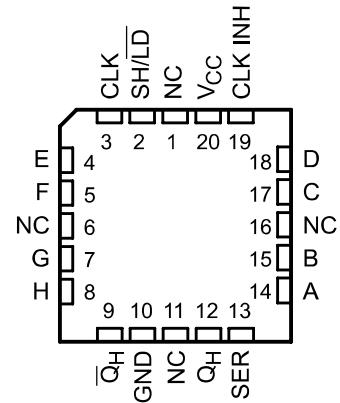

Pin Functions⁽¹⁾

PIN			I/O	DESCRIPTION
NAME	D, DB, N, NS, PW, J or W	FK		
A	11	14	I	Parallel Input
B	12	15	I	Parallel Input
C	13	17	I	Parallel Input
CLK	2	3	I	Clock input
CLK INH	15	19	I	Clock Inhibit, when High No change in output
D	14	18	I	Parallel Input
E	3	4	I	Parallel Input
F	4	5	I	Parallel Input
G	5	7	I	Parallel Input
GND	8	10	—	Ground Pin
H	6	8	I	Parallel Input
NC	—	1	—	Not Connected
		6		
		11		
		16		
QH	9	12	O	Serial Output
\overline{Q}_H	7	9	O	Complementary Serial Output
SER	10	13	I	Serial Input
SH/ \overline{LD}	1	2	I	Shift or Load input, When High Data, shifted. When Low data is loaded from parallel inputs
V _{CC}	16	20	—	Power Pin

(1) NC – No internal connection

6 Specifications

6.1 Absolute Maximum Ratings

 over operating free-air temperature range (unless otherwise noted)⁽¹⁾

		MIN	MAX	UNIT
V _{CC}	Supply voltage	−0.5	7	V
I _{IK}	Input clamp current ⁽²⁾	V _I < 0 or V _I > V _{CC}		±20 mA
I _{OK}	Output clamp current ⁽²⁾	V _O < 0 or V _O > V _{CC}		±20 mA
I _O	Continuous output current	V _O = 0 to V _{CC}		±25 mA
	Continuous current through V _{CC} or GND			±50 mA
T _{stg}	Storage temperature	−65	150	°C

- (1) Stresses beyond those listed under *Absolute Maximum Ratings* may cause permanent damage to the device. These are stress ratings only, and functional operation of the device at these or any other conditions beyond those indicated under *Recommended Operating Conditions* is not implied. Exposure to absolute-maximum-rated conditions for extended periods may affect device reliability.
- (2) The input and output voltage ratings may be exceeded if the input and output current ratings are observed.

6.2 ESD Ratings

			VALUE	UNIT
V _(ESD)	Electrostatic discharge	Human body model (HBM), per ANSI/ESDA/JEDEC JS-001 ⁽¹⁾	±1500	V

- (1) JEDEC document JEP155 states that 500-V HBM allows safe manufacturing with a standard ESD control process.

6.3 Recommended Operating Conditions

 over operating free-air temperature range (unless otherwise noted)⁽¹⁾

		MIN	NOM	MAX	UNIT
V _{CC}	Supply voltage	2	5	6	V
V _{IH}	High-level input voltage	V _{CC} = 2 V	1.5		V
		V _{CC} = 4.5 V	3.15		
		V _{CC} = 6 V	4.2		
V _{IL}	Low level input voltage	V _{CC} = 2 V	0.5		V
		V _{CC} = 4.5 V	1.35		
		V _{CC} = 6 V	1.8		
V _I	Input voltage	0	V _{CC}		V
V _O	Output voltage	0	V _{CC}		V
Δt/Δv ⁽²⁾	Input transition rise and fall time	V _{CC} = 2 V	1000		ns/V
		V _{CC} = 4.5 V	500		
		V _{CC} = 6 V	400		
T _A	Operating free-air temperature	SN54HC165	−55	125	°C
		SN74HC165	−40	125	

- (1) All unused inputs of the device must be held at V_{CC} or GND to ensure proper device operation. Refer to the TI application report, *Implications of Slow or Floating CMOS Inputs*, literature number [SCBA004](#).
- (2) If this device is used in the threshold region (from V_{IL} max = 0.5 V to V_{IH} min = 1.5 V), there is a potential to go into the wrong state from induced grounding, causing double clocking. Operating with the inputs at t_i = 1000 ns and V_{CC} = 2 V does not damage the device; however, functionally, the CLK inputs are not ensured while in the shift, count, or toggle operating modes.

6.4 Thermal Information

THERMAL METRIC ⁽¹⁾	SN74HC165					UNIT	
	D (SOIC)	DB (SSOP)	N (DIP)	NS (SO)	PW (TSSOP)		
R _{θJA}	Junction-to-ambient thermal resistance	73	82	67	64	108	°C/W

- (1) For more information about traditional and new thermal metrics, see the *Semiconductor and IC Package Thermal Metrics* application report, [SPRA953](#).

6.5 Electrical Characteristics, $T_A = 25^\circ\text{C}$

over recommended operating free-air temperature range for both the SN74HC165 and SN54HC165 (unless otherwise noted)

PARAMETER	TEST CONDITIONS		V_{CC}	MIN	TYP	MAX	UNIT
V_{OH}	$V_I = V_{IH}$ or V_{IL}	$I_{OH} = -20\ \mu\text{A}$	2 V	1.9	1.998		V
			4.5 V	4.4	4.499		
			6 V	5.9	5.999		
		$I_{OH} = -4\ \text{mA}$	4.5 V	3.98	4.3		
			6 V	5.48	5.8		
V_{OL}	$V_I = V_{IH}$ or V_{IL}	$I_{OL} = 20\ \mu\text{A}$	2 V		0.002	0.1	V
			4.5 V		0.001	0.1	
			6 V		0.001	0.1	
		$I_{OL} = 4\ \text{mA}$	4.5 V		0.17	0.26	
			6 V		0.15	0.26	
I_I	$V_I = V_{CC}$ or 0		6 V		± 0.1	± 100	nA
I_{CC}	$V_I = V_{CC}$ or 0,	$I_O = 0$	6 V			8	μA
C_i			2 V to 6 V		3	10	pF

6.6 Electrical Characteristics, SN54HC165

 over recommended operating free-air temperature range, $T_A = -55^\circ\text{C}$ to 125°C (unless otherwise noted)

PARAMETER	TEST CONDITIONS		V_{CC}	MIN	TYP	MAX	UNIT
V_{OH}	$V_I = V_{IH}$ or V_{IL}	$I_{OH} = -20\ \mu\text{A}$	2 V	1.9			V
			4.5 V	4.4			
			6 V	5.9			
		$I_{OH} = -4\ \text{mA}$	4.5 V	3.7			
			6 V	5.2			
V_{OL}	$V_I = V_{IH}$ or V_{IL}	$I_{OL} = 20\ \mu\text{A}$	2 V			0.1	V
			4.5 V			0.1	
			6 V			0.1	
		$I_{OL} = 4\ \text{mA}$	4.5 V			0.4	
			6 V			0.4	
I_I	$V_I = V_{CC}$ or 0		6 V			± 1000	nA
I_{CC}	$V_I = V_{CC}$ or 0,	$I_O = 0$	6 V			160	μA
C_i			2 V to 6 V			10	pF

6.7 Electrical Characteristics, SN74HC165

over recommended operating free-air temperature range (unless otherwise noted)

PARAMETER	TEST CONDITIONS		V_{CC}	MIN	TYP	MAX	UNIT
V_{OH}	$V_I = V_{IH}$ or V_{IL}	$I_{OH} = -20\ \mu\text{A}$	$T_A = -40^\circ\text{C}$ to 125°C	2 V	1.9		V
				4.5 V	4.4		
				6 V	5.9		
		$I_{OH} = -4\ \text{mA}$	$T_A = -40^\circ\text{C}$ to 85°C	4.5 V	3.84		
					$T_A = -40^\circ\text{C}$ to 125°C	3.7	
				$I_{OH} = -5.2\ \text{mA}$	$T_A = -40^\circ\text{C}$ to 85°C	6 V	
$T_A = -40^\circ\text{C}$ to 125°C	5.2						
V_{OL}	$V_I = V_{IH}$ or V_{IL}	$I_{OL} = 20\ \mu\text{A}$	$T_A = -40^\circ\text{C}$ to 125°C	2 V		0.1	V
				4.5 V		0.1	
				6 V		0.1	
		$I_{OL} = 4\ \text{mA}$	$T_A = -40^\circ\text{C}$ to 125°C	4.5 V		0.33	
				6 V		0.33	

Electrical Characteristics, SN74HC165 (continued)

over recommended operating free-air temperature range (unless otherwise noted)

PARAMETER	TEST CONDITIONS		V _{CC}	MIN	TYP	MAX	UNIT
I _I	V _I = V _{CC} or 0	T _A = –40°C to 125°C	6 V			±1000	nA
I _{CC}	V _I = V _{CC} or 0, I _O = 0	T _A = –40°C to 85°C	6 V			80	μA
		T _A = –40°C to 125°C				160	
C _i	Recommended T _A = –40°C to 125°C		2 V to 6 V			10	pF

6.8 Switching Characteristics, T_A = 25°C

 over recommended operating free-air temperature range for both the SN74HC165 and SN54HC165, C_L = 50 pF (unless otherwise noted) (see [Figure 2](#))

PARAMETER	FROM (INPUT)	TO (OUTPUT)	V _{CC}	MIN	TYP	MAX	UNIT
f _{max}			2 V	6	13		MHz
			4.5 V	31	50		
			6 V	36	62		
t _{pd}	SH/ $\overline{\text{LD}}$	Q _H or $\overline{\text{Q}}_{\text{H}}$	2 V		80	150	ns
			4.5 V		20	30	
			6 V		16	26	
	CLK	Q _H or $\overline{\text{Q}}_{\text{H}}$	2 V		75	150	
			4.5 V		15	30	
			6 V		13	26	
	H	Q _H or $\overline{\text{Q}}_{\text{H}}$	2 V		75	150	
			4.5 V		15	30	
			6 V		13	26	
t _t		Any	2 V		38	75	ns
			4.5 V		8	15	
			6 V		6	13	

6.9 Switching Characteristics, SN54HC165

 over recommended operating free-air temperature range, T_A = –55°C to 125°C, C_L = 50 pF (unless otherwise noted) (see [Figure 2](#))

PARAMETER	FROM (INPUT)	TO (OUTPUT)	V _{CC}	MIN	MAX	UNIT
f _{max}			2 V	4.2		MHz
			4.5 V	21		
			6 V	25		
t _{pd}	SH/ $\overline{\text{LD}}$	Q _H or $\overline{\text{Q}}_{\text{H}}$	2 V		225	ns
			4.5 V		45	
			6 V		38	
	CLK	Q _H or $\overline{\text{Q}}_{\text{H}}$	2 V		225	
			4.5 V		45	
			6 V		38	
	H	Q _H or $\overline{\text{Q}}_{\text{H}}$	2 V		225	
			4.5 V		45	
			6 V		38	
t _t		Any	2 V		110	ns
			4.5 V		22	
			6 V		19	

6.10 Switching Characteristics, SN74HC165

 over recommended operating free-air temperature range, $C_L = 50$ pF (unless otherwise noted) (see [Figure 2](#))

PARAMETER	FROM (INPUT)	TO (OUTPUT)	V_{CC}	TEMPERATURE	MIN	MAX	UNIT
f_{max}			2 V	$T_A = -40^\circ\text{C to } 85^\circ\text{C}$	5		MHz
				$T_A = -40^\circ\text{C to } 125^\circ\text{C}$	4.2		
			4.5 V	$T_A = -40^\circ\text{C to } 85^\circ\text{C}$	25		
				$T_A = -40^\circ\text{C to } 125^\circ\text{C}$	21		
			6 V	$T_A = -40^\circ\text{C to } 85^\circ\text{C}$	29		
				$T_A = -40^\circ\text{C to } 125^\circ\text{C}$	25		
t_{pd}	SH/ $\overline{\text{LD}}$	Q_H or \overline{Q}_H	2 V	$T_A = -40^\circ\text{C to } 85^\circ\text{C}$		190	ns
				$T_A = -40^\circ\text{C to } 125^\circ\text{C}$		225	
			4.5 V	$T_A = -40^\circ\text{C to } 85^\circ\text{C}$		38	
				$T_A = -40^\circ\text{C to } 125^\circ\text{C}$		45	
			6 V	$T_A = -40^\circ\text{C to } 85^\circ\text{C}$		32	
				$T_A = -40^\circ\text{C to } 125^\circ\text{C}$		38	
	CLK	Q_H or \overline{Q}_H	2 V	$T_A = -40^\circ\text{C to } 85^\circ\text{C}$		190	
				$T_A = -40^\circ\text{C to } 125^\circ\text{C}$		225	
			4.5 V	$T_A = -40^\circ\text{C to } 85^\circ\text{C}$		38	
				$T_A = -40^\circ\text{C to } 125^\circ\text{C}$		45	
			6 V	$T_A = -40^\circ\text{C to } 85^\circ\text{C}$		32	
				$T_A = -40^\circ\text{C to } 125^\circ\text{C}$		38	
	H	Q_H or \overline{Q}_H	2 V	$T_A = -40^\circ\text{C to } 85^\circ\text{C}$		190	
				$T_A = -40^\circ\text{C to } 125^\circ\text{C}$		225	
			4.5 V	$T_A = -40^\circ\text{C to } 85^\circ\text{C}$		38	
				$T_A = -40^\circ\text{C to } 125^\circ\text{C}$		45	
			6 V	$T_A = -40^\circ\text{C to } 85^\circ\text{C}$		32	
				$T_A = -40^\circ\text{C to } 125^\circ\text{C}$		38	
t_t		Any	2 V	$T_A = -40^\circ\text{C to } 85^\circ\text{C}$		95	
				$T_A = -40^\circ\text{C to } 125^\circ\text{C}$		110	
			4.5 V	$T_A = -40^\circ\text{C to } 85^\circ\text{C}$		19	
				$T_A = -40^\circ\text{C to } 125^\circ\text{C}$		22	
			6 V	$T_A = -40^\circ\text{C to } 85^\circ\text{C}$		16	
				$T_A = -40^\circ\text{C to } 125^\circ\text{C}$		19	

6.11 Timing Requirements, $T_A = 25^\circ\text{C}$

over recommended operating free-air temperature range for both the SN74HC165 and SN54HC165 (unless otherwise noted)

		V_{CC}	MIN	MAX	UNIT
f_{clock}	Clock frequency	2 V		6	MHz
		4.5 V		31	
		6 V		36	
t_w	SH/ $\overline{\text{LD}}$ low	2 V	80		ns
		4.5 V	16		
		6 V	14		
	CLK high or low	2 V	80		
		4.5 V	16		
		6 V	14		

Timing Requirements, $T_A = 25^\circ\text{C}$ (continued)

over recommended operating free-air temperature range for both the SN74HC165 and SN54HC165 (unless otherwise noted)

		V_{CC}	MIN	MAX	UNIT
t_{su}	SH/ \overline{LD} high before CLK \uparrow	2 V	80		ns
		4.5 V	16		
		6 V	14		
	SER before CLK \uparrow	2 V	40		
		4.5 V	8		
		6 V	7		
	CLK INH low before CLK \uparrow	2 V	100		
		4.5 V	20		
		6 V	17		
	CLK INH high before CLK \uparrow	2 V	40		
		4.5 V	8		
		6 V	7		
Data before SH/ \overline{LD} \downarrow	2 V	100			
	4.5 V	20			
	6 V	17			
t_h	SER data after CLK \uparrow	2 V	5		ns
		4.5 V	5		
		6 V	5		
	PAR data after SH/ \overline{LD} \downarrow	2 V	5		
		4.5 V	5		
		6 V	5		

6.12 Timing Requirements, SN54HC165

 over recommended operating free-air temperature range, $T_A = -55^\circ\text{C}$ to 125°C (unless otherwise noted)

		V_{CC}	MIN	MAX	UNIT
f_{clock}	Clock frequency	2 V		4.2	MHz
		4.5 V		21	
		6 V		25	
t_w	SH/ \overline{LD} low	2 V	120		ns
		4.5 V	24		
		6 V	20		
	CLK high or low	2 V	120		
		4.5 V	24		
		6 V	20		

Timing Requirements, SN54HC165 (continued)

 over recommended operating free-air temperature range, $T_A = -55^\circ\text{C}$ to 125°C (unless otherwise noted)

		V_{CC}	MIN	MAX	UNIT
t_{su}	Set-up time	SH/ $\overline{\text{LD}}$ high before CLK \uparrow	2 V	120	ns
			4.5 V	24	
			6 V	20	
		SER before CLK \uparrow	2 V	60	
			4.5 V	12	
			6 V	10	
	CLK INH low before CLK \uparrow	2 V	150		
		4.5 V	30		
		6 V	25		
	CLK INH high before CLK \uparrow	2 V	60		
		4.5 V	12		
		6 V	10		
Data before SH/ $\overline{\text{LD}}$ \downarrow	2 V	150			
	4.5 V	30			
	6 V	26			
t_h	Hold time	SER data after CLK \uparrow	2 V	5	ns
			4.5 V	5	
			6 V	5	
	PAR data after SH/ $\overline{\text{LD}}$ \downarrow	2 V	5		
		4.5 V	5		
		6 V	5		

6.13 Timing Requirements, SN74HC165

over recommended operating free-air temperature range (unless otherwise noted)

PARAMETER		V_{CC}	TEMPERATURE	MIN	MAX	UNIT
f_{clock}	Clock frequency	2 V	$T_A = -40^\circ\text{C}$ to 85°C		5	MHz
			$T_A = -40^\circ\text{C}$ to 125°C		4.2	
		4.5 V	$T_A = -40^\circ\text{C}$ to 85°C		25	
			$T_A = -40^\circ\text{C}$ to 125°C		21	
		6 V	$T_A = -40^\circ\text{C}$ to 85°C		29	
			$T_A = -40^\circ\text{C}$ to 125°C		25	
t_w	Pulse duration	SH/ $\overline{\text{LD}}$ low	2 V	$T_A = -40^\circ\text{C}$ to 85°C	100	ns
				$T_A = -40^\circ\text{C}$ to 125°C	120	
			4.5 V	$T_A = -40^\circ\text{C}$ to 85°C	20	
				$T_A = -40^\circ\text{C}$ to 125°C	24	
		6 V	$T_A = -40^\circ\text{C}$ to 85°C	17		
			$T_A = -40^\circ\text{C}$ to 125°C	20		
	CLK high or low	2 V	$T_A = -40^\circ\text{C}$ to 85°C	100		
			$T_A = -40^\circ\text{C}$ to 125°C	120		
		4.5 V	$T_A = -40^\circ\text{C}$ to 85°C	20		
			$T_A = -40^\circ\text{C}$ to 125°C	24		
		6 V	$T_A = -40^\circ\text{C}$ to 85°C	17		
			$T_A = -40^\circ\text{C}$ to 125°C	20		

Timing Requirements, SN74HC165 (continued)

over recommended operating free-air temperature range (unless otherwise noted)

PARAMETER		V _{CC}	TEMPERATURE	MIN	MAX	UNIT
t _{su}	SH/LD high before CLK↑	2 V	T _A = –40°C to 85°C	100		ns
			T _A = –40°C to 125°C	120		
		4.5 V	T _A = –40°C to 85°C	20		
			T _A = –40°C to 125°C	24		
		6 V	T _A = –40°C to 85°C	17		
			T _A = –40°C to 125°C	20		
	SER before CLK↑	2 V	T _A = –40°C to 85°C	50		
			T _A = –40°C to 125°C	60		
		4.5 V	T _A = –40°C to 85°C	10		
			T _A = –40°C to 125°C	12		
		6 V	T _A = –40°C to 85°C	9		
			T _A = –40°C to 125°C	10		
	CLK INH low before CLK↑	2 V	T _A = –40°C to 85°C	125		
			T _A = –40°C to 125°C	150		
		4.5 V	T _A = –40°C to 85°C	25		
			T _A = –40°C to 125°C	30		
		6 V	T _A = –40°C to 85°C	21		
			T _A = –40°C to 125°C	25		
	CLK INH high before CLK↑	2 V	T _A = –40°C to 85°C	50		
			T _A = –40°C to 125°C	60		
4.5 V		T _A = –40°C to 85°C	10			
		T _A = –40°C to 125°C	12			
6 V		T _A = –40°C to 85°C	9			
		T _A = –40°C to 125°C	10			
Data before SH/LD↓	2 V	T _A = –40°C to 85°C	125			
		T _A = –40°C to 125°C	150			
	4.5 V	T _A = –40°C to 85°C	25			
		T _A = –40°C to 125°C	30			
	6 V	T _A = –40°C to 85°C	21			
		T _A = –40°C to 125°C	26			
t _h	SER data after CLK↑	2 V	T _A = –40°C to 125°C	5		ns
		4.5 V	T _A = –40°C to 125°C	5		
		6 V	T _A = –40°C to 125°C	5		
	PAR data after SH/LD↓	2 V	T _A = –40°C to 125°C	5		
		4.5 V	T _A = –40°C to 125°C	5		
		6 V	T _A = –40°C to 125°C	5		

6.14 Operating Characteristics

 T_A = 25°C

PARAMETER	TEST CONDITIONS	TYP	UNIT
C _{pd} Power dissipation capacitance	No load	75	pF

6.15 Typical Characteristics

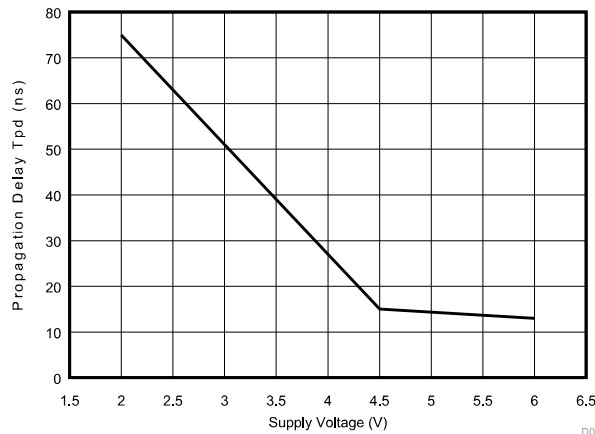
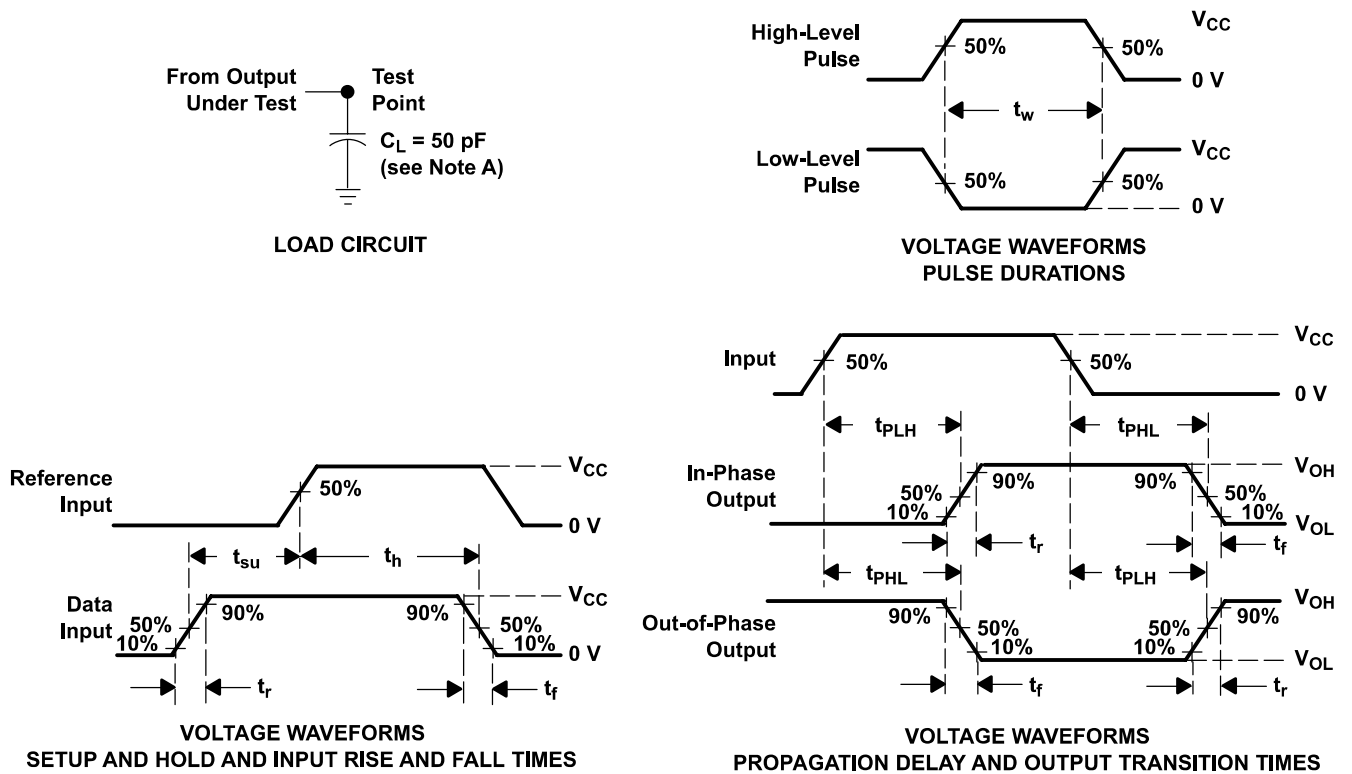

Figure 1. Propagation Delay vs Supply Voltage at $T_A = 25^\circ\text{C}$

7 Parameter Measurement Information



- NOTES:
- A. C_L includes probe and test-fixture capacitance.
 - B. Phase relationships between waveforms were chosen arbitrarily. All input pulses are supplied by generators having the following characteristics: $\text{PRR} \leq 1 \text{ MHz}$, $Z_O = 50 \Omega$, $t_r = 6 \text{ ns}$, $t_f = 6 \text{ ns}$.
 - C. For clock inputs, f_{max} is measured when the input duty cycle is 50%.
 - D. The outputs are measured one at a time with one input transition per measurement.
 - E. t_{PLH} and t_{PHL} are the same as t_{pd} .

Figure 2. Load Circuit and Voltage Waveforms

8 Detailed Description

8.1 Overview

The SNx4HC165 is an 8-bit Parallel load shift register with 1 serial input and 8 parallel load input. The device loads all the 8 bits simultaneously through parallel load input when SH/LD is low. This will also ignore any input at CLK or CLK INH.

The device shifts the data when CLK toggles. The data is shifted on rising edge of the clock. Clock Inhibit (CLK INH) inhibits the clock function resulting in no change of the output. If SH/LD is low clock inputs are ignored. To realize the shift function, SH/LD should be high.

CLK and CLK INH functions are interchangeable. If CLK is low then change a clock signal at CLK INH pin causes a shift of data to Q_H. If CLK INH is Low clock signal on CLK pin shifts the data out to Q_H.

8.2 Functional Block Diagram

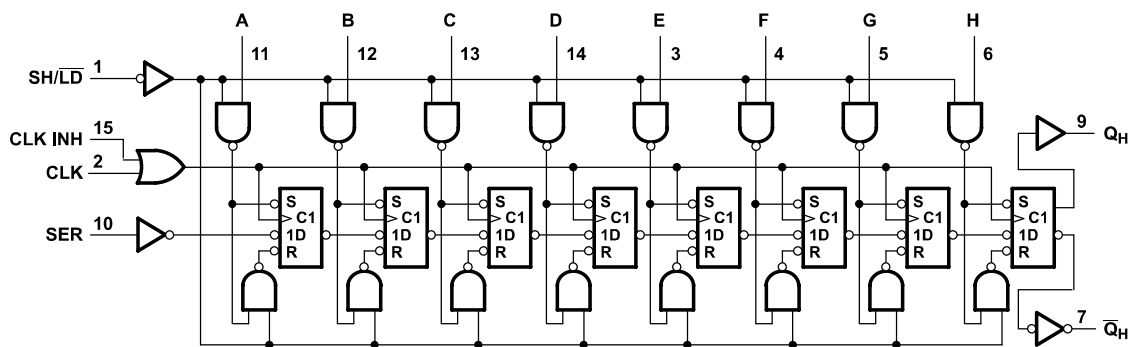

Pin numbers shown are for the D, DB, J, N, NS, PW and W packages.

Figure 3. Logic Diagram Positive Logic

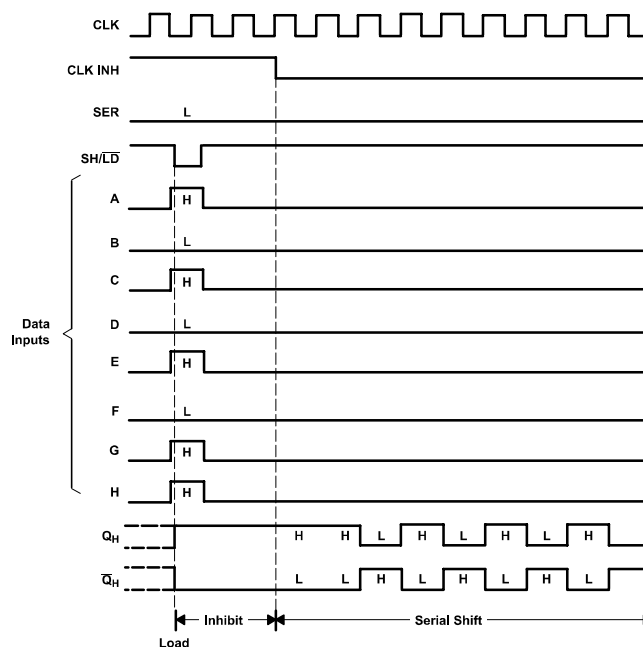

Figure 4. Typical Shift, Load, and Inhibit Sequence

8.3 Feature Description

The SNx4HC165 has a wide operating voltage range of 2 V to 6 V, outputs that can drive up to 10 LSTTL loads and Low Power Consumption, 80- μ A maximum I. It is typically $t_{pd} = 13$ ns and has ± 4 -mA output drive at 5 V with low input current of 1- μ A maximum. The device features the direct overloading load of data input, meaning parallel data is loaded irrespective of clock signals.

8.4 Device Functional Table

Table 1 lists the functional modes of the SNx4HC165.

Table 1. Function Table

SH/LD	INPUTS		FUNCTION
	CLK	CLK INH	
L	X	X	Parallel load
H	H	X	No change
H	X	H	No change
H	L	\uparrow	Shift ⁽¹⁾
H	\uparrow	L	Shift ⁽¹⁾

(1) Shift : Content of each internal register shifts towards serial output Q_H . Data at SER is shifted into the first register

9 Application and Implementation

NOTE

Information in the following applications sections is not part of the TI component specification, and TI does not warrant its accuracy or completeness. TI's customers are responsible for determining suitability of components for their purposes. Customers should validate and test their design implementation to confirm system functionality.

9.1 Application Information

The SNx4HC165 is an 8-bit shift register that can be used as a serializer in order to reduce the number of connection needed when transmitting signals between boards or to the device. SNx4HC165 can be used to expand inputs for processors with limited GPIOs for examples basic keyboard interface to the controller. SNx4HC165 allows inputs to be load into the shift registers and clock is used to shift data to the processor. Multiple SNx4HC165 can be cascaded together to allow more digital inputs to be interfaced with single processor by connecting output of the cascaded shift register Q_H to serial input SER of the SNx4HC165 and so on. Note this application does not allow the communication to be bi-direction in nature as data can only be read by the processor not written back.

9.2 Typical Application

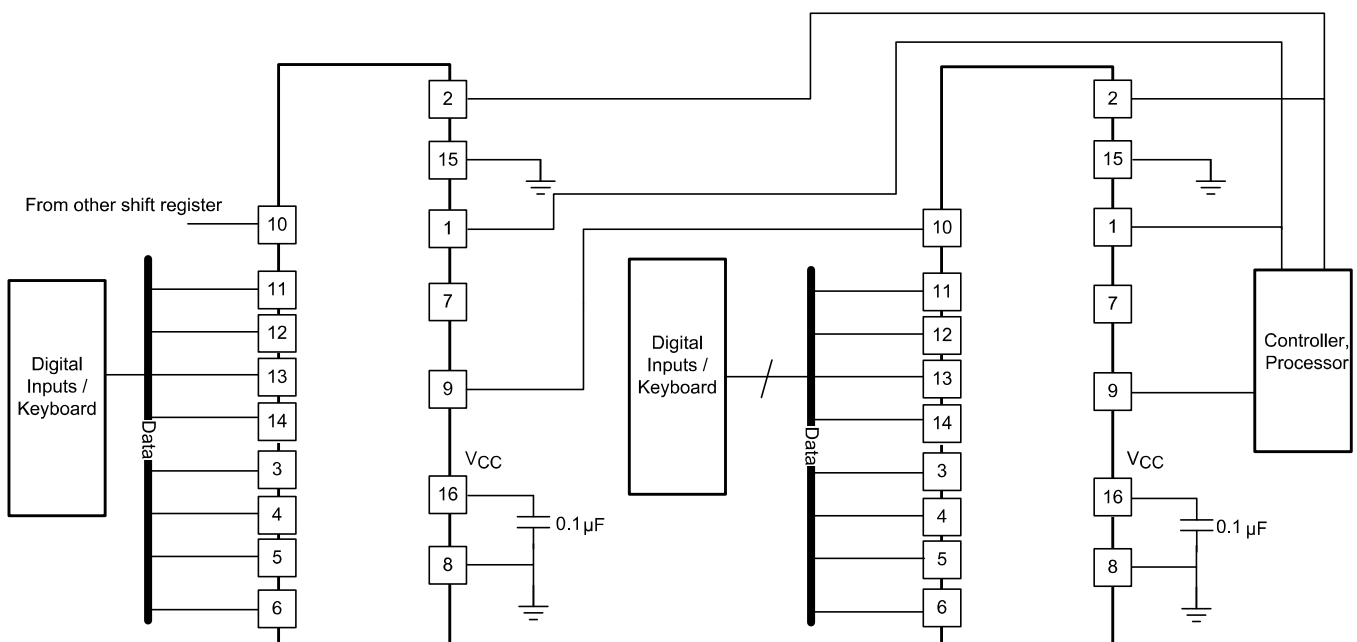

Figure 5. Typical Application Diagram for SN74HC165

9.2.1 Design Requirements

Ensure that the incoming clock rising edge meets the criteria in [Recommended Operating Conditions](#).

9.2.2 Detailed Design Procedure

Ensure that input and output voltages do not exceed ratings in [Absolute Maximum Ratings](#).

Input voltage threshold information for each device can be found in the Electrical Characteristics tables in the [Specifications](#) section.

Detailed timing requirements for each device can be found in Timing Requirements tables in the [Specifications](#) section.

Typical Application (continued)

9.2.3 Application Curve

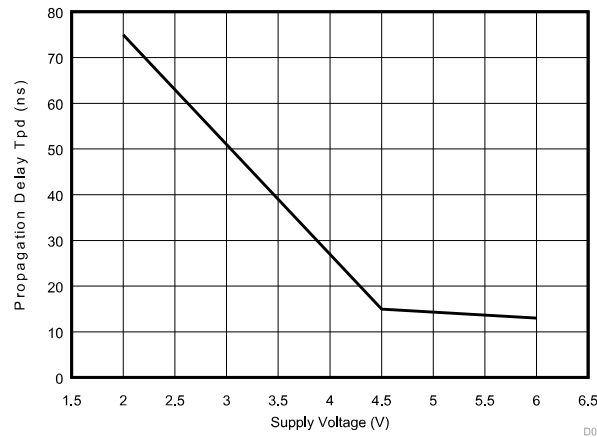

Figure 6. Propagation Delay vs Supply Voltage at $T_A = 25^\circ\text{C}$

10 Power Supply Recommendations

The power supply can be any voltage between the minimum and maximum supply voltage rating located in the [Recommended Operating Conditions](#) table.

Each V_{CC} pin must have a good bypass capacitor in order to prevent power disturbance. For devices with a single supply, a 0.1- μF capacitor is recommended and if there are multiple V_{CC} pins then a 0.01- μF or 0.022- μF capacitor is recommended for each power pin. It is ok to parallel multiple bypass caps to reject different frequencies of noise. 0.1- μF and 1- μF capacitors are commonly used in parallel. The bypass capacitor should be installed as close to the power pin as possible for best results.

11 Layout

11.1 Layout Guidelines

Reflections and matching are closely related to loop antenna theory, but different enough to warrant their own discussion. When a PCB trace turns a corner at a 90° angle, a reflection can occur. This is primarily due to the change of width of the trace. At the apex of the turn, the trace width is increased to 1.414 times its width. This upsets the transmission line characteristics, especially the distributed capacitance and self-inductance of the trace — resulting in the reflection. It is a given that not all PCB traces can be straight, and so they will have to turn corners. [Figure 7](#) shows progressively better techniques of rounding corners. Only the last example maintains constant trace width and minimizes reflections.

11.2 Layout Example

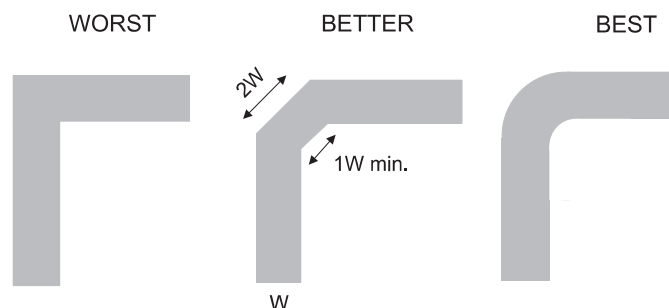

Figure 7. Trace Example

12 Device and Documentation Support

12.1 Documentation Support

12.1.1 Related Documentation

Implications of Slow or Floating CMOS Inputs, [SCBA004](#).

12.2 Related Links

The table below lists quick access links. Categories include technical documents, support and community resources, tools and software, and quick access to sample or buy.

Table 2. Related Links

PARTS	PRODUCT FOLDER	SAMPLE & BUY	TECHNICAL DOCUMENTS	TOOLS & SOFTWARE	SUPPORT & COMMUNITY
SN54HC165	Click here	Click here	Click here	Click here	Click here
SN74HC165	Click here	Click here	Click here	Click here	Click here

12.3 Community Resources

The following links connect to TI community resources. Linked contents are provided "AS IS" by the respective contributors. They do not constitute TI specifications and do not necessarily reflect TI's views; see TI's [Terms of Use](#).

TI E2E™ Online Community *TI's Engineer-to-Engineer (E2E) Community*. Created to foster collaboration among engineers. At e2e.ti.com, you can ask questions, share knowledge, explore ideas and help solve problems with fellow engineers.

Design Support *TI's Design Support* Quickly find helpful E2E forums along with design support tools and contact information for technical support.

12.4 Trademarks

E2E is a trademark of Texas Instruments.
All other trademarks are the property of their respective owners.

12.5 Electrostatic Discharge Caution



These devices have limited built-in ESD protection. The leads should be shorted together or the device placed in conductive foam during storage or handling to prevent electrostatic damage to the MOS gates.

12.6 Glossary

[SLYZ022](#) — *TI Glossary*.

This glossary lists and explains terms, acronyms and definitions.

13 Mechanical, Packaging, and Orderable Information

The following pages include mechanical packaging and orderable information. This information is the most current data available for the designated devices. This data is subject to change without notice and revision of this document. For browser based versions of this data sheet, refer to the left hand navigation.

PACKAGE OPTION ADDENDUM

PACKAGING INFORMATION

Orderable Device	Status (1)	Package Type	Package Drawing	Package Pins	Package Qty	Eco Plan (2)	Lead finish/ Ball material (6)	MSL Peak Temp (3)	Op Temp (°C)	Device Marking (4/5)	Samples
84095012A	ACTIVE	LCCC	FK	20	1	Non-RoHS & Green	POST-PLATE	N / A for Pkg Type	-55 to 125	84095012A SNJ54HC 165FK	Samples
8409501EA	ACTIVE	CDIP	J	16	1	Non-RoHS & Green	SNPB	N / A for Pkg Type	-55 to 125	8409501EA SNJ54HC165J	Samples
8409501FA	ACTIVE	CFP	W	16	1	Non-RoHS & Green	SNPB	N / A for Pkg Type	-55 to 125	8409501FA SNJ54HC165W	Samples
SN54HC165J	ACTIVE	CDIP	J	16	1	Non-RoHS & Green	SNPB	N / A for Pkg Type	-55 to 125	SN54HC165J	Samples
SN74HC165D	ACTIVE	SOIC	D	16	40	RoHS & Green	NIPDAU	Level-1-260C-UNLIM	-40 to 125	HC165	Samples
SN74HC165DBR	ACTIVE	SSOP	DB	16	2000	RoHS & Green	NIPDAU	Level-1-260C-UNLIM	-40 to 125	HC165	Samples
SN74HC165DE4	ACTIVE	SOIC	D	16	40	RoHS & Green	NIPDAU	Level-1-260C-UNLIM	-40 to 125	HC165	Samples
SN74HC165DG4	ACTIVE	SOIC	D	16	40	RoHS & Green	NIPDAU	Level-1-260C-UNLIM	-40 to 125	HC165	Samples
SN74HC165DR	ACTIVE	SOIC	D	16	2500	RoHS & Green	NIPDAU SN	Level-1-260C-UNLIM	-40 to 125	HC165	Samples
SN74HC165DRE4	ACTIVE	SOIC	D	16	2500	RoHS & Green	NIPDAU	Level-1-260C-UNLIM	-40 to 125	HC165	Samples
SN74HC165DRG3	ACTIVE	SOIC	D	16	2500	RoHS & Green	SN	Level-1-260C-UNLIM	-40 to 125	HC165	Samples
SN74HC165DRG4	ACTIVE	SOIC	D	16	2500	RoHS & Green	NIPDAU	Level-1-260C-UNLIM	-40 to 125	HC165	Samples
SN74HC165DST	ACTIVE	SOIC	D	16	250	RoHS & Green	NIPDAU	Level-1-260C-UNLIM	-40 to 125	HC165	Samples
SN74HC165N	ACTIVE	PDIP	N	16	25	RoHS & Green	NIPDAU SN	N / A for Pkg Type	-40 to 125	SN74HC165N	Samples
SN74HC165NE4	ACTIVE	PDIP	N	16	25	RoHS & Green	NIPDAU	N / A for Pkg Type	-40 to 125	SN74HC165N	Samples
SN74HC165NSR	ACTIVE	SO	NS	16	2000	RoHS & Green	NIPDAU	Level-1-260C-UNLIM	-40 to 125	HC165	Samples
SN74HC165PW	ACTIVE	TSSOP	PW	16	90	RoHS & Green	NIPDAU	Level-1-260C-UNLIM	-40 to 125	HC165	Samples
SN74HC165PWR	ACTIVE	TSSOP	PW	16	2000	RoHS & Green	NIPDAU SN	Level-1-260C-UNLIM	-40 to 125	HC165	Samples
SN74HC165PWRG3	ACTIVE	TSSOP	PW	16	2000	RoHS & Green	SN	Level-1-260C-UNLIM	-40 to 125	HC165	Samples

PACKAGE OPTION ADDENDUM

Orderable Device	Status (1)	Package Type	Package Drawing	Package Pins	Package Qty	Eco Plan (2)	Lead finish/ Ball material (6)	MSL Peak Temp (3)	Op Temp (°C)	Device Marking (4/5)	Samples
SN74HC165PWRG4	ACTIVE	TSSOP	PW	16	2000	RoHS & Green	NIPDAU	Level-1-260C-UNLIM	-40 to 125	HC165	Samples
SN74HC165PWT	ACTIVE	TSSOP	PW	16	250	RoHS & Green	NIPDAU	Level-1-260C-UNLIM	-40 to 125	HC165	Samples
SNJ54HC165FK	ACTIVE	LCCC	FK	20	1	Non-RoHS & Green	POST-PLATE	N / A for Pkg Type	-55 to 125	84095012A SNJ54HC 165FK	Samples
SNJ54HC165J	ACTIVE	CDIP	J	16	1	Non-RoHS & Green	SNPB	N / A for Pkg Type	-55 to 125	8409501EA SNJ54HC165J	Samples
SNJ54HC165W	ACTIVE	CFP	W	16	1	Non-RoHS & Green	SNPB	N / A for Pkg Type	-55 to 125	8409501FA SNJ54HC165W	Samples

(1) The marketing status values are defined as follows:

ACTIVE: Product device recommended for new designs.

LIFEBUY: TI has announced that the device will be discontinued, and a lifetime-buy period is in effect.

NRND: Not recommended for new designs. Device is in production to support existing customers, but TI does not recommend using this part in a new design.

PREVIEW: Device has been announced but is not in production. Samples may or may not be available.

OBSOLETE: TI has discontinued the production of the device.

(2) **RoHS:** TI defines "RoHS" to mean semiconductor products that are compliant with the current EU RoHS requirements for all 10 RoHS substances, including the requirement that RoHS substance do not exceed 0.1% by weight in homogeneous materials. Where designed to be soldered at high temperatures, "RoHS" products are suitable for use in specified lead-free processes. TI may reference these types of products as "Pb-Free".

RoHS Exempt: TI defines "RoHS Exempt" to mean products that contain lead but are compliant with EU RoHS pursuant to a specific EU RoHS exemption.

Green: TI defines "Green" to mean the content of Chlorine (Cl) and Bromine (Br) based flame retardants meet JS709B low halogen requirements of <=1000ppm threshold. Antimony trioxide based flame retardants must also meet the <=1000ppm threshold requirement.

(3) **MSL, Peak Temp.** - The Moisture Sensitivity Level rating according to the JEDEC industry standard classifications, and peak solder temperature.

(4) There may be additional marking, which relates to the logo, the lot trace code information, or the environmental category on the device.

(5) Multiple Device Markings will be inside parentheses. Only one Device Marking contained in parentheses and separated by a "-" will appear on a device. If a line is indented then it is a continuation of the previous line and the two combined represent the entire Device Marking for that device.

(6) Lead finish/Ball material - Orderable Devices may have multiple material finish options. Finish options are separated by a vertical ruled line. Lead finish/Ball material values may wrap to two lines if the finish value exceeds the maximum column width.

Important Information and Disclaimer: The information provided on this page represents TI's knowledge and belief as of the date that it is provided. TI bases its knowledge and belief on information provided by third parties, and makes no representation or warranty as to the accuracy of such information. Efforts are underway to better integrate information from third parties. TI has taken and continues to take reasonable steps to provide representative and accurate information but may not have conducted destructive testing or chemical analysis on incoming materials and chemicals. TI and TI suppliers consider certain information to be proprietary, and thus CAS numbers and other limited information may not be available for release.

In no event shall TI's liability arising out of such information exceed the total purchase price of the TI part(s) at issue in this document sold by TI to Customer on an annual basis.

OTHER QUALIFIED VERSIONS OF SN54HC165, SN74HC165 :

- Catalog: [SN74HC165](#)
 - Automotive: [SN74HC165-Q1](#), [SN74HC165-Q1](#)
 - Enhanced Product: [SN74HC165-EP](#), [SN74HC165-EP](#)
 - Military: [SN54HC165](#)
- NOTE: Qualified Version Definitions:
- Catalog - TI's standard catalog product
 - Automotive - Q100 devices qualified for high-reliability automotive applications targeting zero defects
 - Enhanced Product - Supports Defense, Aerospace and Medical Applications
 - Military - QML certified for Military and Defense Applications

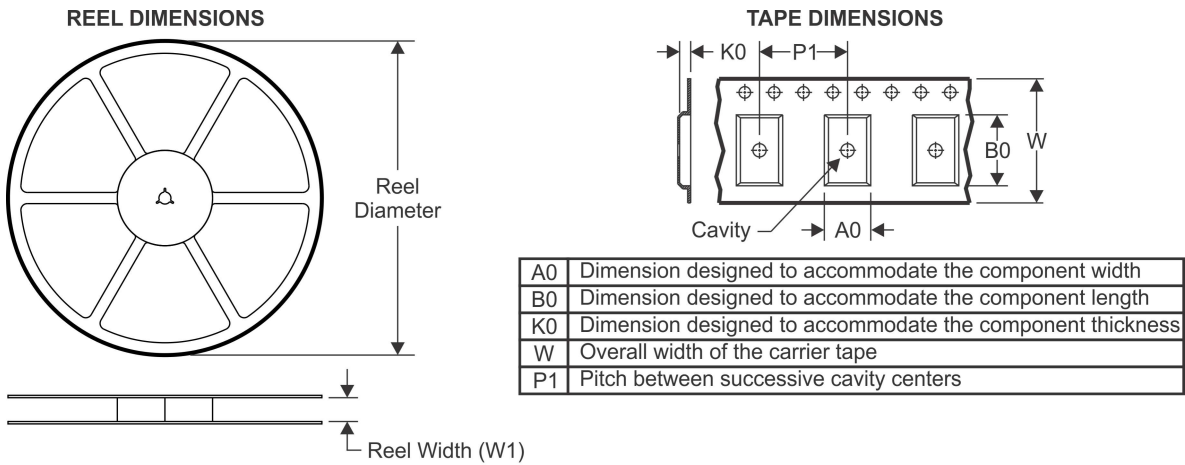
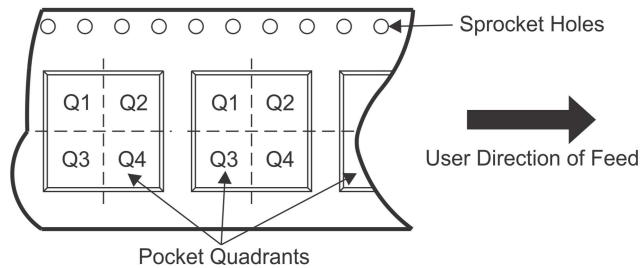
TAPE AND REEL INFORMATION

QUADRANT ASSIGNMENTS FOR PIN 1 ORIENTATION IN TAPE

*All dimensions are nominal

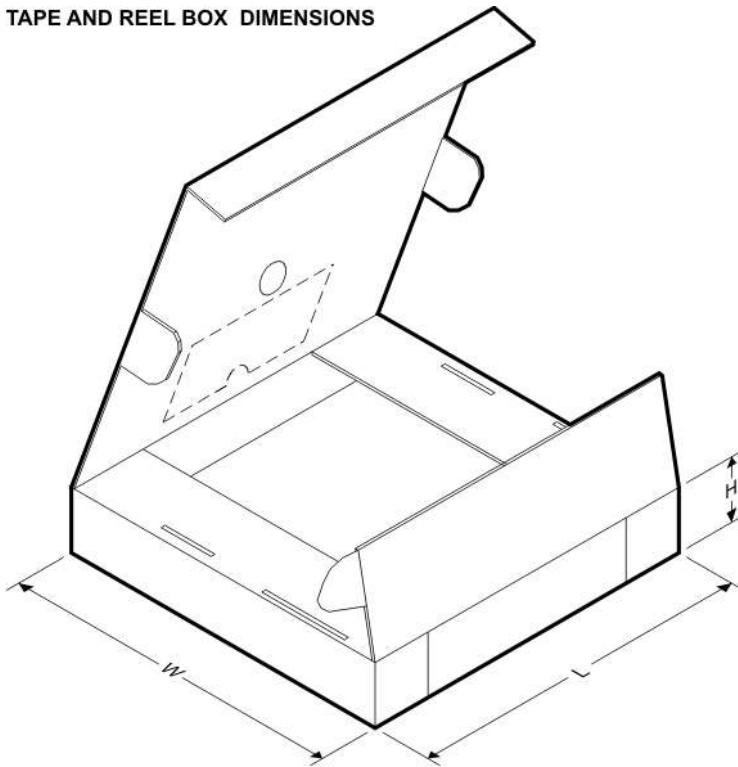
Device	Package Type	Package Drawing	Pins	SPQ	Reel Diameter (mm)	Reel Width W1 (mm)	A0 (mm)	B0 (mm)	K0 (mm)	P1 (mm)	W (mm)	Pin1 Quadrant
SN74HC165DR	SOIC	D	16	2500	330.0	16.8	6.5	10.3	2.1	8.0	16.0	Q1
SN74HC165DR	SOIC	D	16	2500	330.0	16.4	6.5	10.3	2.1	8.0	16.0	Q1
SN74HC165DR	SOIC	D	16	2500	330.0	16.4	6.5	10.3	2.1	8.0	16.0	Q1
SN74HC165DRG3	SOIC	D	16	2500	330.0	16.8	6.5	10.3	2.1	8.0	16.0	Q1
SN74HC165DRG4	SOIC	D	16	2500	330.0	16.4	6.5	10.3	2.1	8.0	16.0	Q1
SN74HC165DRG4	SOIC	D	16	2500	330.0	16.4	6.5	10.3	2.1	8.0	16.0	Q1
SN74HC165NSR	SO	NS	16	2000	330.0	16.4	8.2	10.5	2.5	12.0	16.0	Q1
SN74HC165PWR	TSSOP	PW	16	2000	330.0	12.4	6.9	5.6	1.6	8.0	12.0	Q1
SN74HC165PWR	TSSOP	PW	16	2000	330.0	12.4	6.9	5.6	1.6	8.0	12.0	Q1
SN74HC165PWRG3	TSSOP	PW	16	2000	330.0	12.4	6.9	5.6	1.6	8.0	12.0	Q1
SN74HC165PWRG4	TSSOP	PW	16	2000	330.0	12.4	6.9	5.6	1.6	8.0	12.0	Q1
SN74HC165PWT	TSSOP	PW	16	250	330.0	12.4	6.9	5.6	1.6	8.0	12.0	Q1

TAPE AND REEL BOX DIMENSIONS

*All dimensions are nominal

Device	Package Type	Package Drawing	Pins	SPQ	Length (mm)	Width (mm)	Height (mm)
SN74HC165DR	SOIC	D	16	2500	364.0	364.0	27.0
SN74HC165DR	SOIC	D	16	2500	853.0	449.0	35.0
SN74HC165DR	SOIC	D	16	2500	333.2	345.9	28.6
SN74HC165DRG3	SOIC	D	16	2500	364.0	364.0	27.0
SN74HC165DRG4	SOIC	D	16	2500	333.2	345.9	28.6
SN74HC165DRG4	SOIC	D	16	2500	853.0	449.0	35.0
SN74HC165NSR	SO	NS	16	2000	853.0	449.0	35.0
SN74HC165PWR	TSSOP	PW	16	2000	364.0	364.0	27.0
SN74HC165PWR	TSSOP	PW	16	2000	853.0	449.0	35.0
SN74HC165PWRG3	TSSOP	PW	16	2000	364.0	364.0	27.0
SN74HC165PWRG4	TSSOP	PW	16	2000	853.0	449.0	35.0
SN74HC165PWT	TSSOP	PW	16	250	853.0	449.0	35.0

FK (S-CQCC-N**)

LEADLESS CERAMIC CHIP CARRIER

28 TERMINAL SHOWN

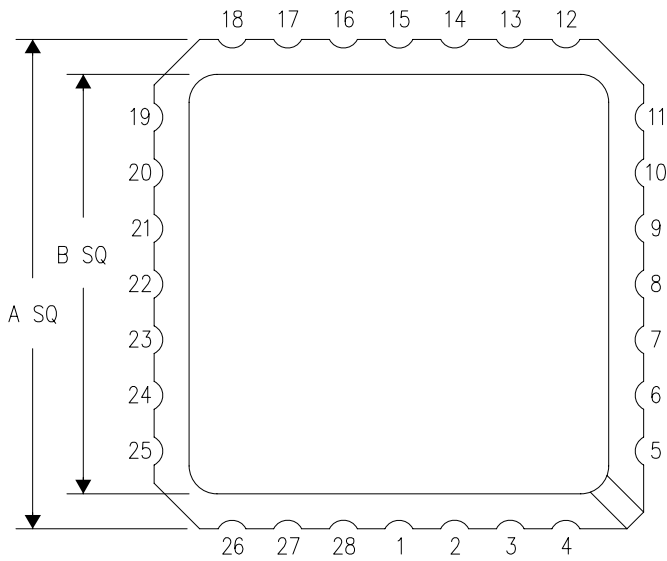

NO. OF TERMINALS **	A		B	
	MIN	MAX	MIN	MAX
20	0.342 (8,69)	0.358 (9,09)	0.307 (7,80)	0.358 (9,09)
28	0.442 (11,23)	0.458 (11,63)	0.406 (10,31)	0.458 (11,63)
44	0.640 (16,26)	0.660 (16,76)	0.495 (12,58)	0.560 (14,22)
52	0.740 (18,78)	0.761 (19,32)	0.495 (12,58)	0.560 (14,22)
68	0.938 (23,83)	0.962 (24,43)	0.850 (21,6)	0.858 (21,8)
84	1.141 (28,99)	1.165 (29,59)	1.047 (26,6)	1.063 (27,0)

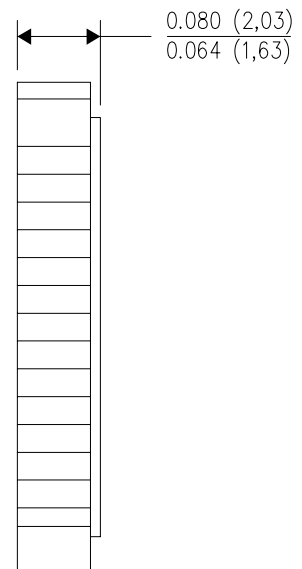
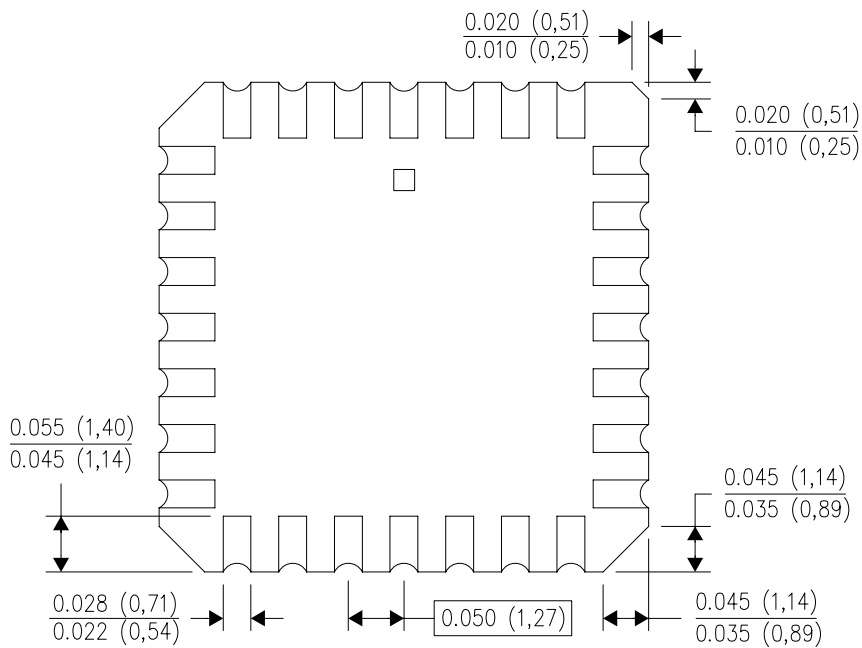

4040140/D 01/11

- NOTES:
- A. All linear dimensions are in inches (millimeters).
 - B. This drawing is subject to change without notice.
 - C. This package can be hermetically sealed with a metal lid.
 - D. Falls within JEDEC MS-004

D (R-PDSO-G16)

PLASTIC SMALL OUTLINE

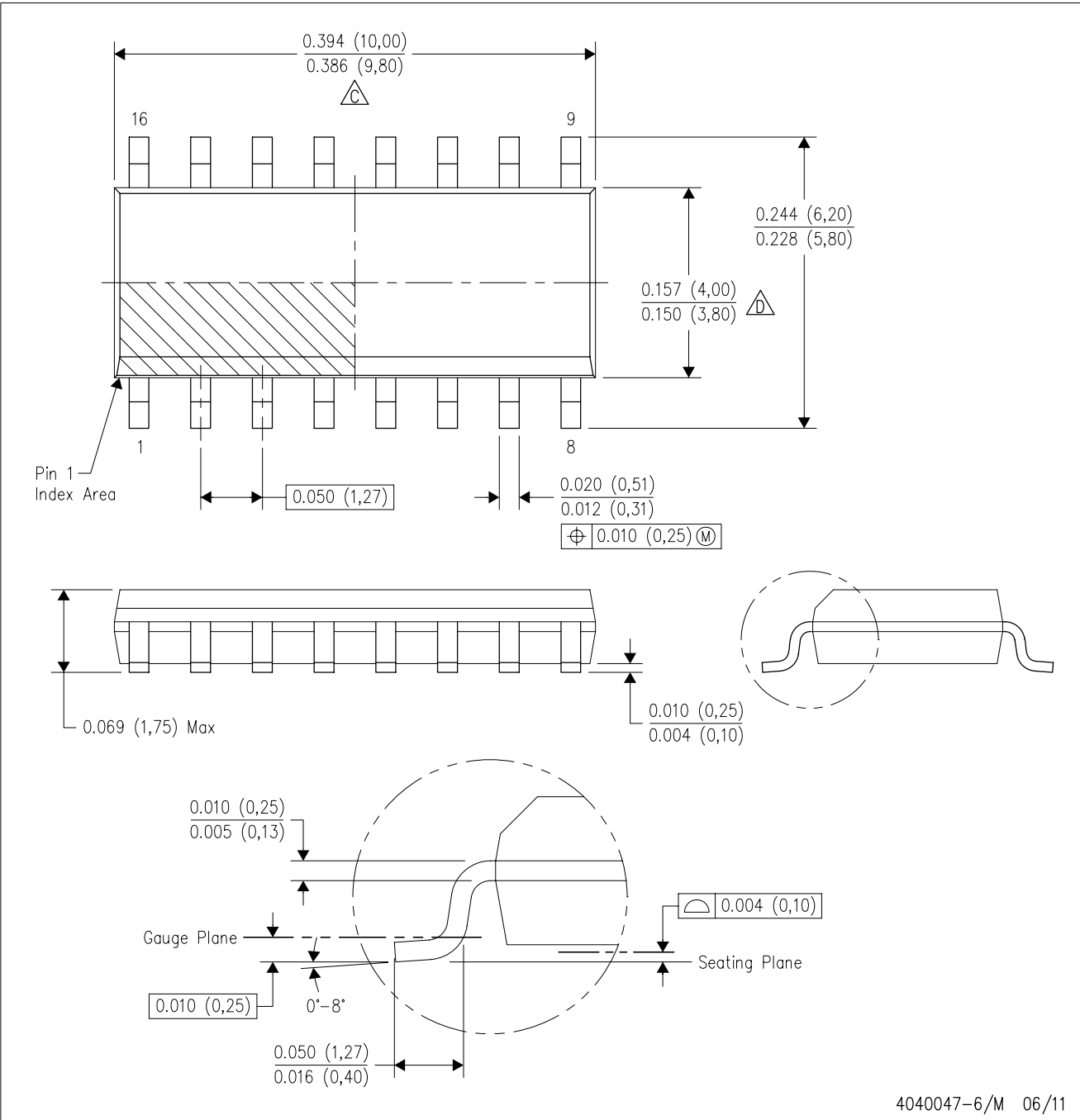

- NOTES:
- A. All linear dimensions are in inches (millimeters).
 - B. This drawing is subject to change without notice.
 - $\triangle C$ Body length does not include mold flash, protrusions, or gate burrs. Mold flash, protrusions, or gate burrs shall not exceed 0.006 (0,15) each side.
 - $\triangle D$ Body width does not include interlead flash. Interlead flash shall not exceed 0.017 (0,43) each side.
 - E. Reference JEDEC MS-012 variation AC.

D (R-PDSO-G16)

PLASTIC SMALL OUTLINE

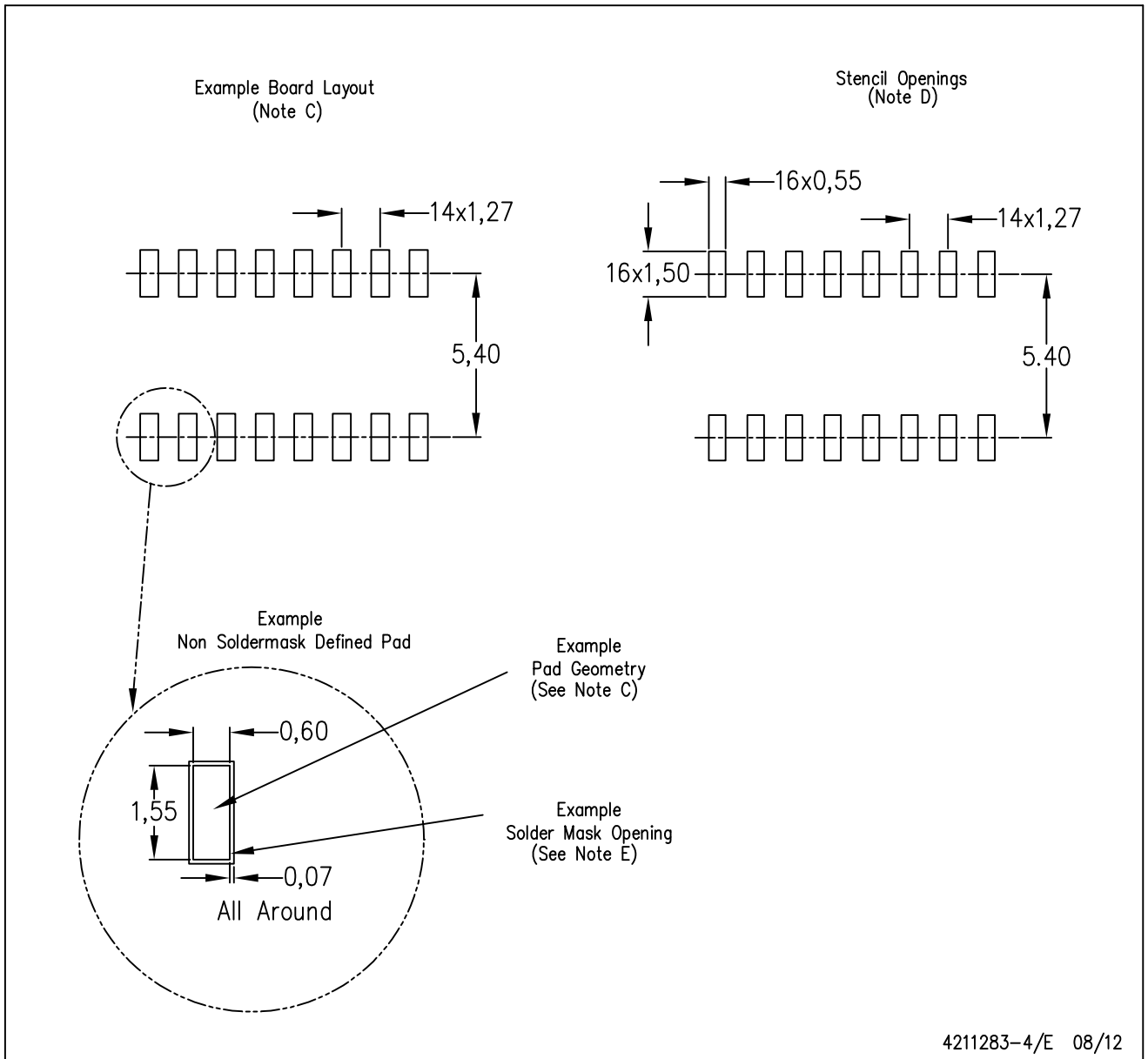

- NOTES:
- A. All linear dimensions are in millimeters.
 - B. This drawing is subject to change without notice.
 - C. Publication IPC-7351 is recommended for alternate designs.
 - D. Laser cutting apertures with trapezoidal walls and also rounding corners will offer better paste release. Customers should contact their board assembly site for stencil design recommendations. Refer to IPC-7525 for other stencil recommendations.
 - E. Customers should contact their board fabrication site for solder mask tolerances between and around signal pads.

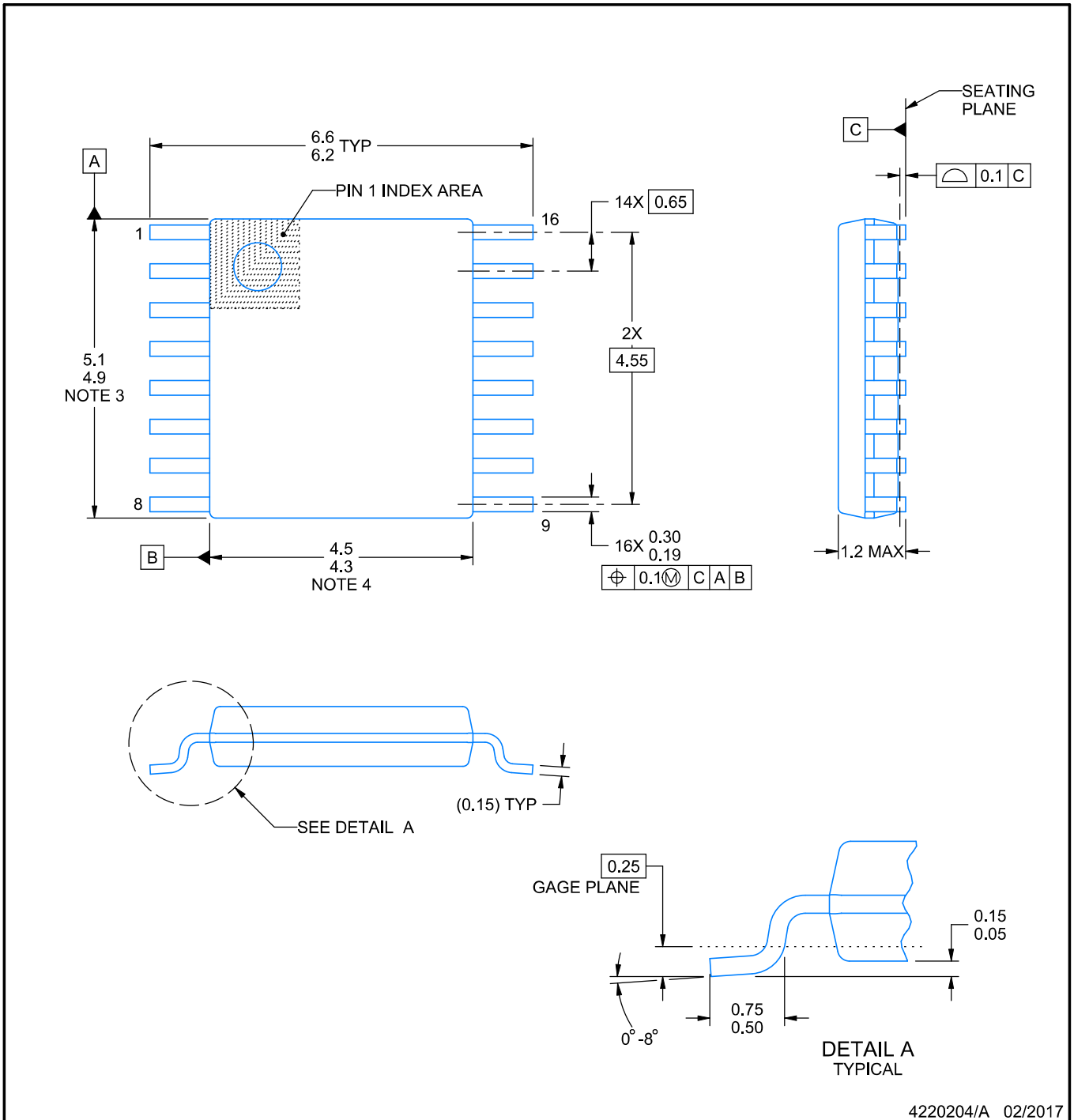

NOTES:

1. All linear dimensions are in millimeters. Any dimensions in parenthesis are for reference only. Dimensioning and tolerancing per ASME Y14.5M.
2. This drawing is subject to change without notice.
3. This dimension does not include mold flash, protrusions, or gate burrs. Mold flash, protrusions, or gate burrs shall not exceed 0.15 mm per side.
4. This dimension does not include interlead flash. Interlead flash shall not exceed 0.25 mm per side.
5. Reference JEDEC registration MO-153.

EXAMPLE BOARD LAYOUT

PW0016A

TSSOP - 1.2 mm max height

SMALL OUTLINE PACKAGE

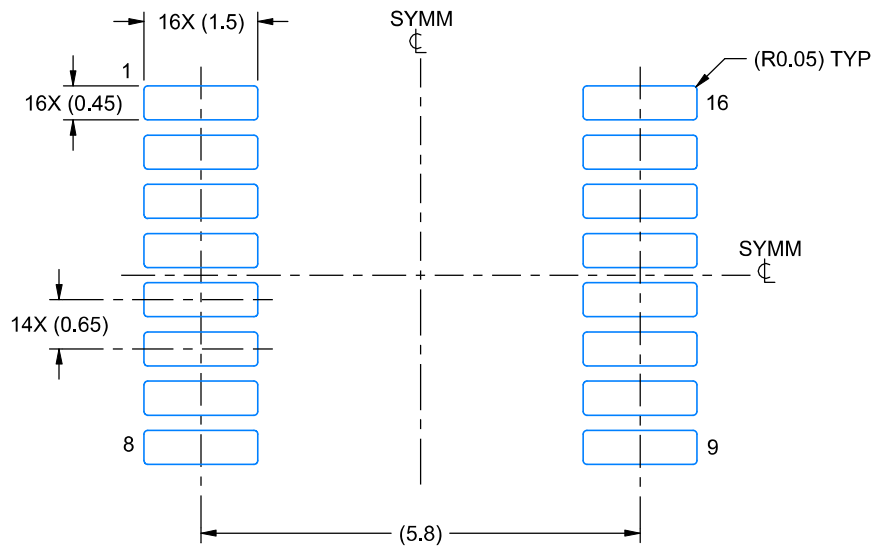

LAND PATTERN EXAMPLE
EXPOSED METAL SHOWN
SCALE: 10X

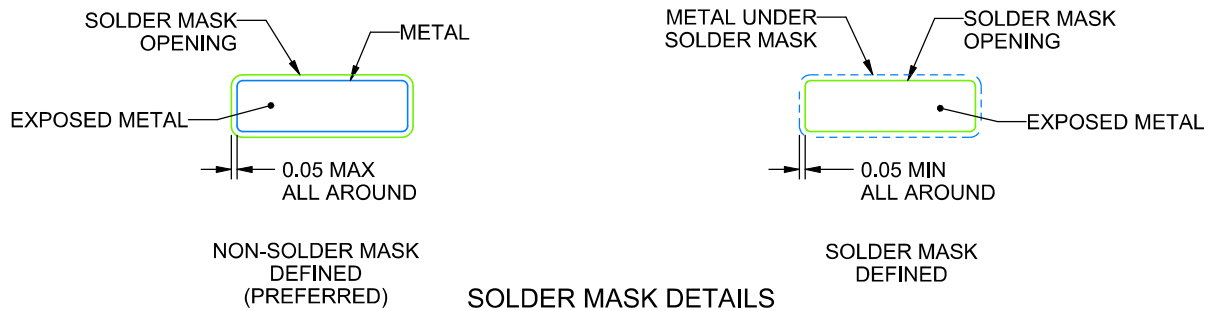

4220204/A 02/2017

NOTES: (continued)

6. Publication IPC-7351 may have alternate designs.

7. Solder mask tolerances between and around signal pads can vary based on board fabrication site.

EXAMPLE STENCIL DESIGN

PW0016A

TSSOP - 1.2 mm max height

SMALL OUTLINE PACKAGE

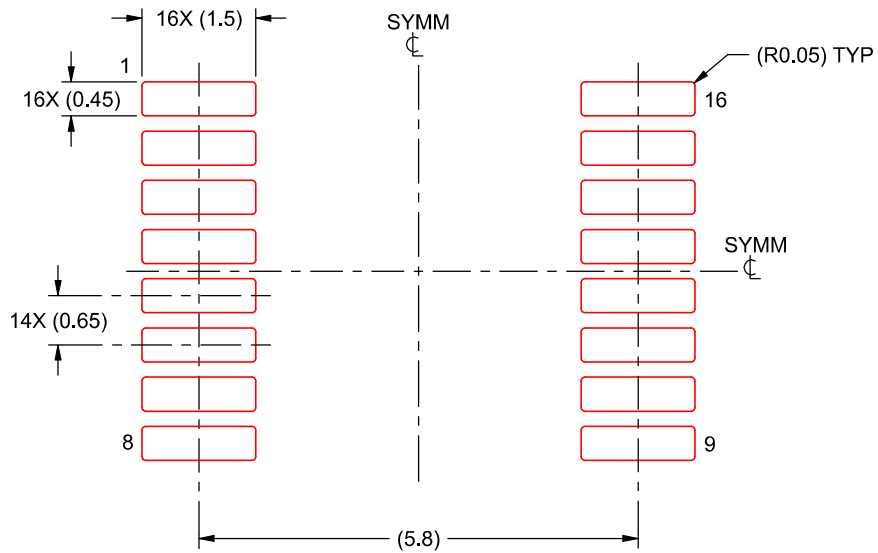

SOLDER PASTE EXAMPLE
BASED ON 0.125 mm THICK STENCIL
SCALE: 10X

4220204/A 02/2017

NOTES: (continued)

8. Laser cutting apertures with trapezoidal walls and rounded corners may offer better paste release. IPC-7525 may have alternate design recommendations.
9. Board assembly site may have different recommendations for stencil design.

MECHANICAL DATA

NS (R-PDSO-G)**

PLASTIC SMALL-OUTLINE PACKAGE

14-PINS SHOWN

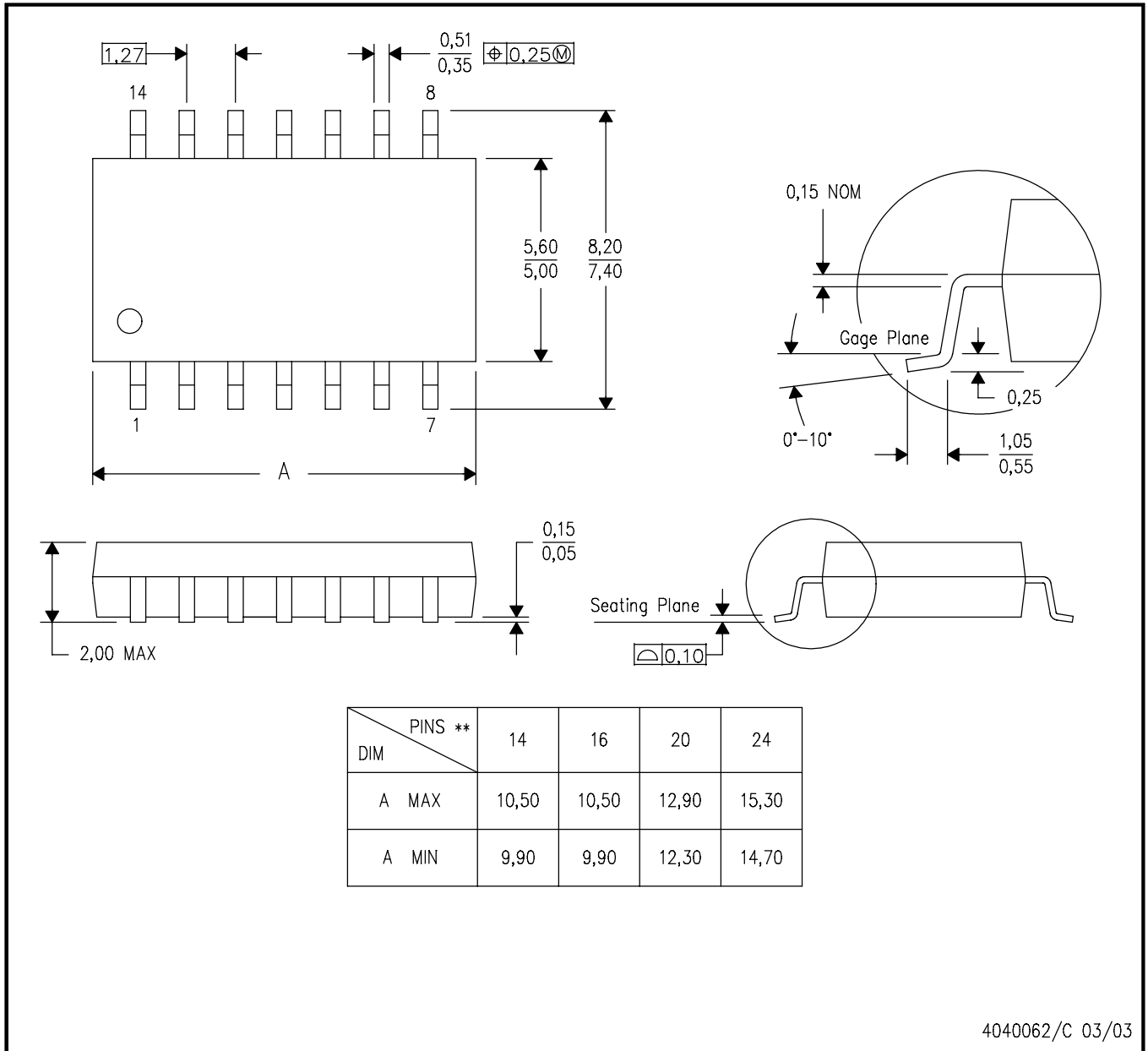

- NOTES:
- A. All linear dimensions are in millimeters.
 - B. This drawing is subject to change without notice.
 - C. Body dimensions do not include mold flash or protrusion, not to exceed 0,15.

W (R-GDFP-F16)

CERAMIC DUAL FLATPACK

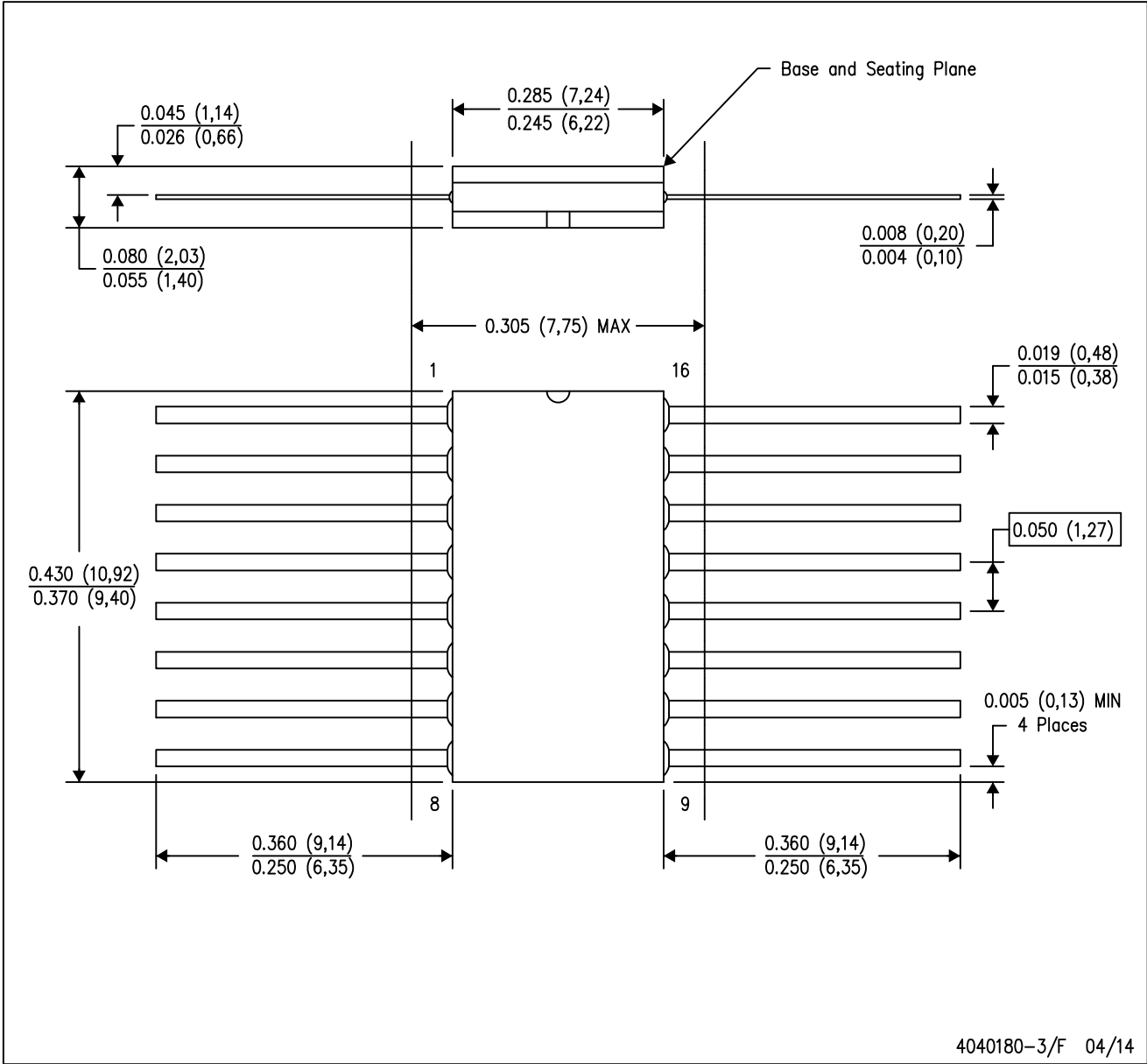

- NOTES:
- A. All linear dimensions are in inches (millimeters).
 - B. This drawing is subject to change without notice.
 - C. This package can be hermetically sealed with a ceramic lid using glass frit.
 - D. Index point is provided on cap for terminal identification only.
 - E. Falls within MIL STD 1835 GDFP2-F16

J (R-GDIP-T**)

14 LEADS SHOWN

CERAMIC DUAL IN-LINE PACKAGE

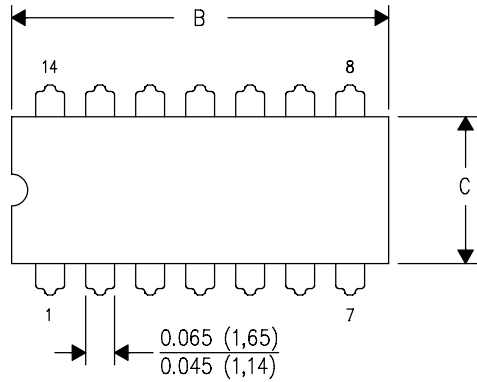

PINS **	14	16	18	20
DIM				
A	0.300 (7,62) BSC	0.300 (7,62) BSC	0.300 (7,62) BSC	0.300 (7,62) BSC
B MAX	0.785 (19,94)	.840 (21,34)	0.960 (24,38)	1.060 (26,92)
B MIN	—	—	—	—
C MAX	0.300 (7,62)	0.300 (7,62)	0.310 (7,87)	0.300 (7,62)
C MIN	0.245 (6,22)	0.245 (6,22)	0.220 (5,59)	0.245 (6,22)

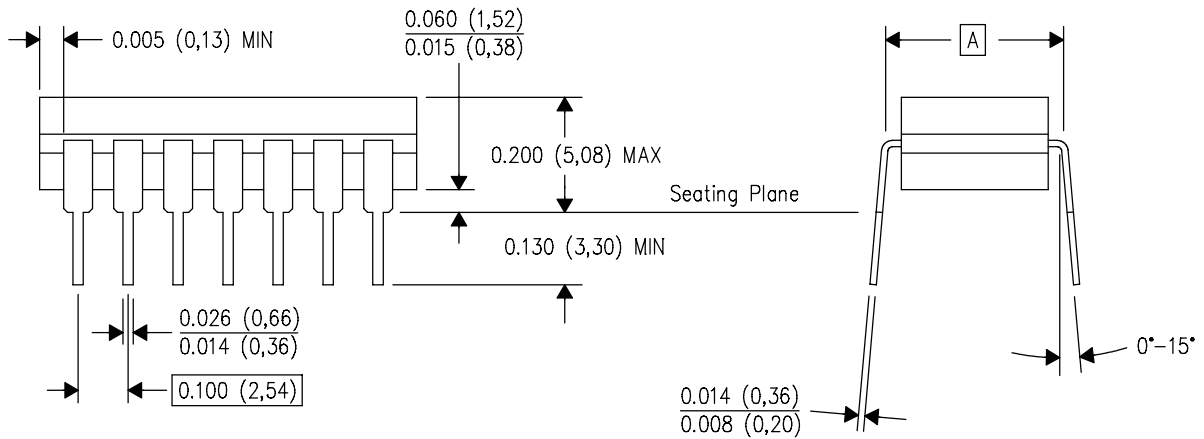

4040083/F 03/03

- NOTES:
- A. All linear dimensions are in inches (millimeters).
 - B. This drawing is subject to change without notice.
 - C. This package is hermetically sealed with a ceramic lid using glass frit.
 - D. Index point is provided on cap for terminal identification only on press ceramic glass frit seal only.
 - E. Falls within MIL STD 1835 GDIP1-T14, GDIP1-T16, GDIP1-T18 and GDIP1-T20.

DB (R-PDSO-G**)

PLASTIC SMALL-OUTLINE

28 PINS SHOWN

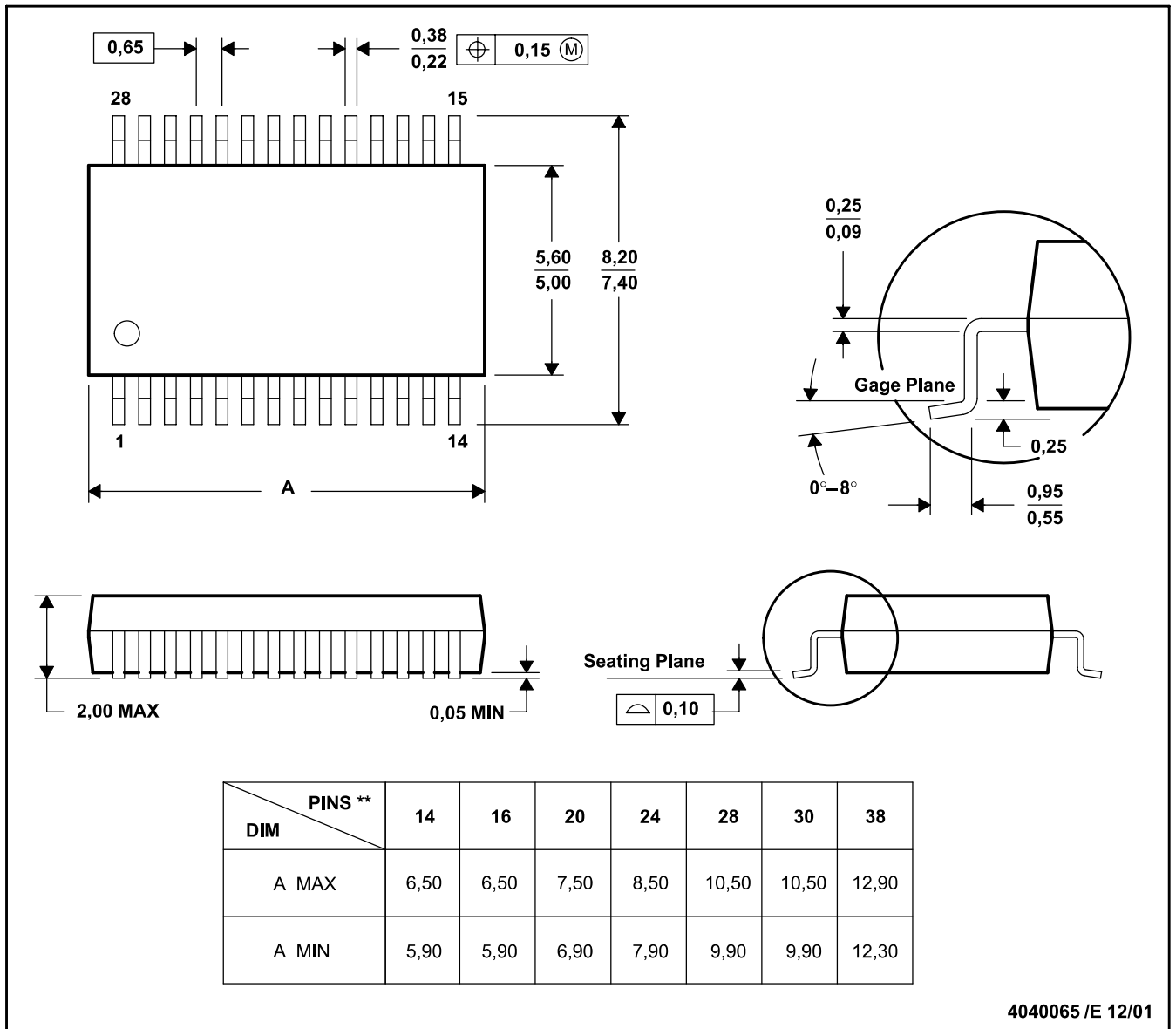

4040065 /E 12/01

- NOTES: A. All linear dimensions are in millimeters.
 B. This drawing is subject to change without notice.
 C. Body dimensions do not include mold flash or protrusion not to exceed 0,15.
 D. Falls within JEDEC MO-150

N (R-PDIP-T**)

PLASTIC DUAL-IN-LINE PACKAGE

16 PINS SHOWN

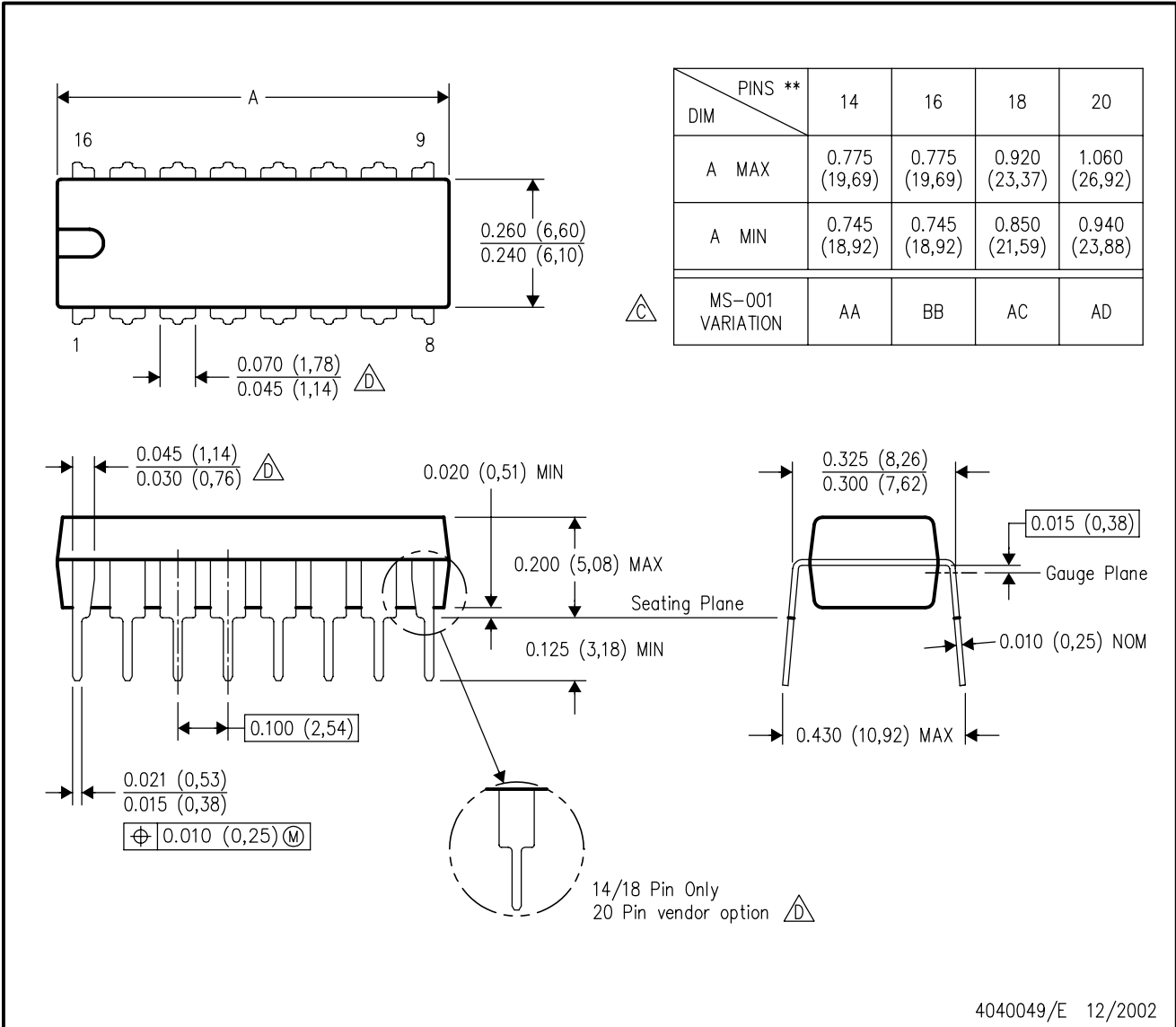

- NOTES:
- A. All linear dimensions are in inches (millimeters).
 - B. This drawing is subject to change without notice.
 - C Falls within JEDEC MS-001, except 18 and 20 pin minimum body length (Dim A).
 - D The 20 pin end lead shoulder width is a vendor option, either half or full width.

IMPORTANT NOTICE AND DISCLAIMER

TI PROVIDES TECHNICAL AND RELIABILITY DATA (INCLUDING DATASHEETS), DESIGN RESOURCES (INCLUDING REFERENCE DESIGNS), APPLICATION OR OTHER DESIGN ADVICE, WEB TOOLS, SAFETY INFORMATION, AND OTHER RESOURCES "AS IS" AND WITH ALL FAULTS, AND DISCLAIMS ALL WARRANTIES, EXPRESS AND IMPLIED, INCLUDING WITHOUT LIMITATION ANY IMPLIED WARRANTIES OF MERCHANTABILITY, FITNESS FOR A PARTICULAR PURPOSE OR NON-INFRINGEMENT OF THIRD PARTY INTELLECTUAL PROPERTY RIGHTS.

These resources are intended for skilled developers designing with TI products. You are solely responsible for (1) selecting the appropriate TI products for your application, (2) designing, validating and testing your application, and (3) ensuring your application meets applicable standards, and any other safety, security, or other requirements. These resources are subject to change without notice. TI grants you permission to use these resources only for development of an application that uses the TI products described in the resource. Other reproduction and display of these resources is prohibited. No license is granted to any other TI intellectual property right or to any third party intellectual property right. TI disclaims responsibility for, and you will fully indemnify TI and its representatives against, any claims, damages, costs, losses, and liabilities arising out of your use of these resources.

TI's products are provided subject to TI's Terms of Sale (<https://www.ti.com/legal/termsofsale.html>) or other applicable terms available either on [ti.com](https://www.ti.com) or provided in conjunction with such TI products. TI's provision of these resources does not expand or otherwise alter TI's applicable warranties or warranty disclaimers for TI products.

Mailing Address: Texas Instruments, Post Office Box 655303, Dallas, Texas 75265
Copyright © 2021, Texas Instruments Incorporated