

11C05

1 GHz Divide-By-Four Counter

The 11C05 is an ECL Divide-By-Four Counter with a maximum operating frequency above 1 GHz over the 0°C to + 75°C temperature range. The input may be DC or AC (capacitively) coupled to the signal source. The emitter follower outputs (Q and \bar{Q}) are capable of driving 50Ω lines. The outputs are voltage-compensated and provide standard ECL output levels.

Rochester Electronics Manufactured Components

Rochester branded components are manufactured using either die/wafers purchased from the original suppliers or Rochester wafers recreated from the original IP. All re-creations are done with the approval of the Original Component Manufacturer (OCM).

Parts are tested using original factory test programs or Rochester developed test solutions to guarantee product meets or exceeds the OCM data sheet.

Quality Overview

- ISO-9001
- AS9120 certification
- Qualified Manufacturers List (QML) MIL-PRF-35835
 - Class Q Military
 - Class V Space Level
- Qualified Suppliers List of Distributors (QSLD)
 - Rochester is a critical supplier to DLA and meets all industry and DLA standards.

Rochester Electronics, LLC is committed to supplying products that satisfy customer expectations for quality and are equal to those originally supplied by industry manufacturers.

The original manufacturer's datasheet accompanying this document reflects the performance and specifications of the Rochester manufactured version of this device. Rochester Electronics guarantees the performance of its semiconductor products to the original OCM specifications. 'Typical' values are for reference purposes only. Certain minimum or maximum ratings may be based on product characterization, design, simulation, or sample testing.

FOR REFERENCE ONLY

11C05 1 GHz Divide-By-Four Counter

General Description

The 11C05 is an ECL Divide-By-Four Counter with a maximum operating frequency above 1 GHz over the 0°C to +75°C temperature range. The input may be DC or AC (capacitively) coupled to the signal source. The emitter follower

outputs (Q and \bar{Q}) are capable of driving 50Ω lines. The outputs are voltage-compensated and provide standard ECL output levels.

Ordering Code: See Section 6

Logic Symbol

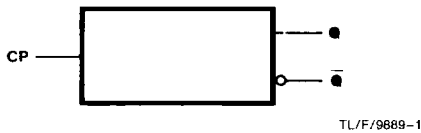

Pin Names	Description
CP	Clock Input
V _{REF}	Reference Input
Q, \bar{Q}	Counter Outputs

Connection Diagram

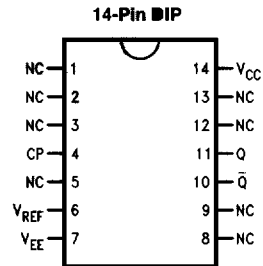

Logic Diagram

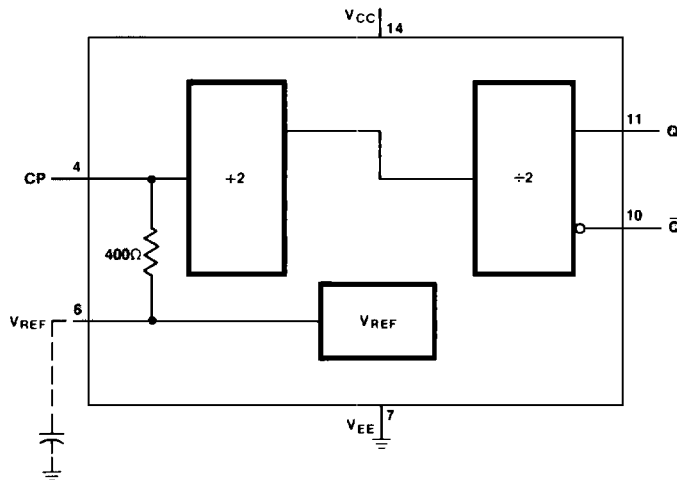

Absolute Maximum Ratings

Above which the useful life may be impaired

Storage Temperature	-65°C to +150°C
Maximum Junction Temperature (T _J)	+150°C
Supply Voltage Range	-7.0V to GND
Input Voltage (DC)	V _{EE} to GND
Output Current (DC Output HIGH)	-50 mA
Operating Range	-5.5V to -4.75V
Lead Temperature (Soldering, 10 sec.)	300°C

Recommended Operating Conditions

	Min	Typ	Max
Supply Voltage (V _{EE})			
Commercial	-5.25V	-5.0V	-4.75V
Military	-5.5V	-5.0V	-4.75V
Ambient Temperature (T _A)			
Commercial	0°C		+75°C
Military	-55°C		+125°C

Commercial DC Electrical CharacteristicsV_{EE} = 5.0V, V_{CC} = GND

Symbol	Parameter	Min	Typ	Max	Units	T _A	Conditions
V _{OH}	Output Voltage HIGH	-1060	-995	-910	mV	0°C	V _{IN} = V _{IH} or V _{IL} , Loading 50Ω to -2V
		-1025	-960	-880	mV	+25°C	
		-980	-910	-830	mV	+75°C	
V _{OL}	Output Voltage LOW	-1810	-1705	-1620	mV	0°C to +75°C	
V _{IH}	Input Voltage HIGH	-2.45			V	0°C	Guaranteed Input HIGH
		-2.50			V	+25°C	
		-2.60			V	+75°C	
V _{IL}	Input Voltage LOW			-3.25	V	0°C	Guaranteed Input LOW
				-3.30	V	+25°C	
				-3.40	V	+75°C	
I _{EE}	Power Supply Current	-90	-65		mA	+25°C	Input Open
V _{EE}	Supply Voltage Range	-5.25	-5.0	-4.75	V	0°C to +75°C	
V _{REF}	Input Reference Voltage		-2.9		V	+25°C	

Military DC Electrical CharacteristicsV_{EE} = -5.0V, V_{CC} = GND

Symbol	Parameter	Min	Typ	Max	Units	T _A	Conditions
V _{OH}	Output Voltage HIGH	-1100	-1030	-950	mV	-55°C	V _{IN} = V _{IH} or V _{IL} , Loading 100Ω to -2V
		-980	-910	-820	mV	+25°C	
		-910	-820	-720	mV	+125°C	
V _{OL}	Output Voltage LOW	-1810	-1705	-1620	mV	-55°C to +125°C	
V _{IH}	Input Voltage HIGH	-2.35			V	-55°C	Guaranteed Input HIGH
		-2.50			V	+25°C	
		-2.70			V	+125°C	
V _{IL}	Input Voltage LOW			-3.15	V	-55°C	Guaranteed Input LOW
				-3.30	V	+25°C	
				-3.50	V	+125°C	
I _{EE}	Power Supply Current	-90	-65		mA	+25°C	Input Open
V _{EE}	Supply Voltage Range	-5.5	-5.0	-4.75	V	-55°C to +125°C	
V _{REF}	Input Reference Voltage		-2.9		V	+25°C	

Commercial and Military AC Electrical Characteristics

$V_{EE} = -5V$, $V_{CC} = GND$, $T_A = -55^{\circ}C$ to $+125^{\circ}C$ unless otherwise noted

Symbol	Parameter	Min	Typ	Max	Units	Conditions
f_{COUNT}	Maximum Sinusoidal Input Frequency	1000			MHz	0°C to +75°C
		950				-55°C to +125°C
f_{COUNT}	Minimum Sinusoidal Input Frequency		25		MHz	AC Coupled 800 mV Peak-to-Peak Input (Note 2)
SR_{MIN}	Slew Rate of Squarewave		50		V/ μ s	(Note 1)

Note 1: Very low frequency operation is possible as long as sufficient slew rate of the input pulse edges is maintained.

Note 2: Input drive shall not exceed 1.5V peak-to-peak max.

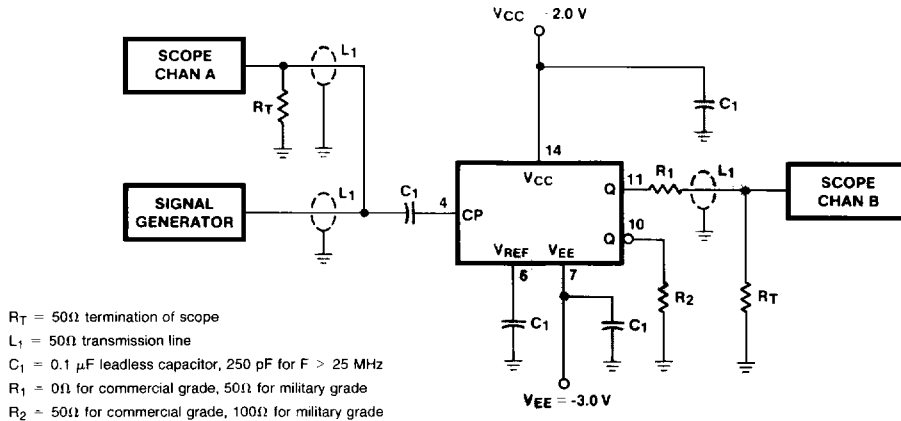
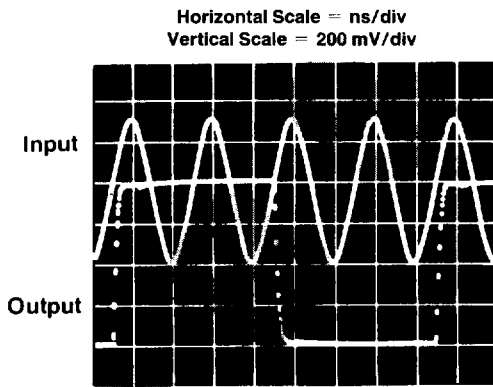

FIGURE 1. AC Test Circuit

TL/F/9889-4



25 MHz Operation

TL/F/9889-5

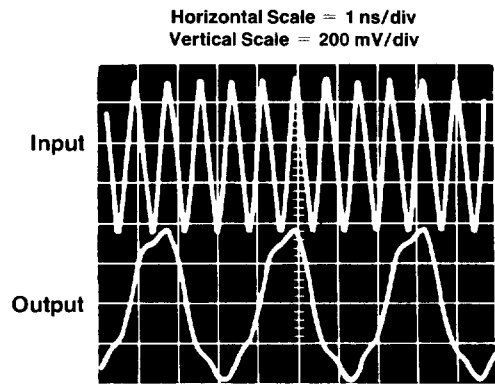

1.2 GHz Operation

TL/F/9889-6

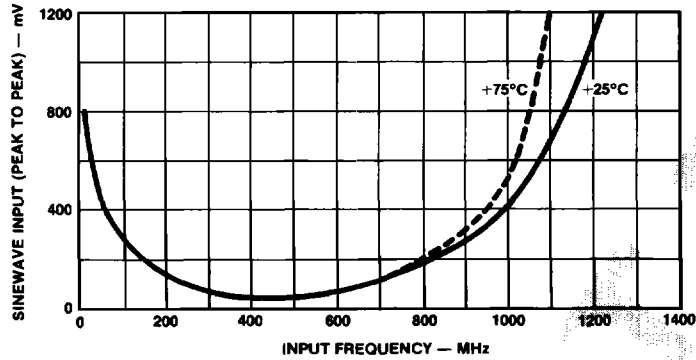

TL/F/9889-7

FIGURE 2. AC Input Requirements

Note: Trigger amplitudes refer to the circuit end of the input cable as opposed to the signal generator end.

A DC coupled input should be designed to provide specified V_{IH} and V_{IL} levels. For AC coupling, an external resistor may or may not be necessary depending on the application. If an input signal is always present, only the capacitor is required because an internal 400Ω resistor connected between CP and V_{REF} centers the AC signal about mid-threshold. For applications in which an input signal is not

always present, AC coupling requires that an external $10\text{K}\Omega$ resistor be connected between CP and V_{EE} . This offsets the input sufficiently to avoid extreme sensitivity to noise when no signal is present. Otherwise, noise triggering can lead to oscillation at about 450 MHz. For best operation, both outputs should be equally loaded.