



SANYO Semiconductors

DATA SHEET

STK621-061-E, — Thick-Film Hybrid IC STK621-061A-E 3-phase Inverter Motor Drive Inverter Hybrid IC

Overview

The STK621-061-E and STK621-061A-E are 3-phase inverter power hybrid IC containing power elements (IGBT and FRD), pre-driver, overcurrent and excessive temperature protection circuit.

Applications

- 3-phase inverter motor drive.

Features

- Integrates power elements (IGBT and FRD), pre-driver, and protective circuit.
- Protective circuits including overcurrent (bus line), excessive temperature and pre-drive low voltage protection are built in.
- Direct input of CMOS level control signals without an insulating circuit (photocoupler, etc) is possible.
- Single power supply drive is possible by using a bootstrap circuit with a built-in IC.
- Temperature monitor is possible by the thermistor inside the IC.
- Built-in simultaneous upper/lower ON prevention circuit to prevent arm shorting through simultaneous ON input for the upper and lower side transistors. (Dead time is required for preventing shorting due to switching delay.)
- SIP (The single in-line package) of the transfer full mold structure.

■ Any and all SANYO Semiconductor Co.,Ltd. products described or contained herein are, with regard to "standard application", intended for the use as general electronics equipment (home appliances, AV equipment, communication device, office equipment, industrial equipment etc.). The products mentioned herein shall not be intended for use for any "special application" (medical equipment whose purpose is to sustain life, aerospace instrument, nuclear control device, burning appliances, transportation machine, traffic signal system, safety equipment etc.) that shall require extremely high level of reliability and can directly threaten human lives in case of failure or malfunction of the product or may cause harm to human bodies, nor shall they grant any guarantee thereof. If you should intend to use our products for applications outside the standard applications of our customer who is considering such use and/or outside the scope of our intended standard applications, please consult with us prior to the intended use. If there is no consultation or inquiry before the intended use, our customer shall be solely responsible for the use.

■ Specifications of any and all SANYO Semiconductor Co.,Ltd. products described or contained herein stipulate the performance, characteristics, and functions of the described products in the independent state, and are not guarantees of the performance, characteristics, and functions of the described products as mounted in the customer's products or equipment. To verify symptoms and states that cannot be evaluated in an independent device, the customer should always evaluate and test devices mounted in the customer's products or equipment.

SANYO Semiconductor Co., Ltd.

TOKYO OFFICE Tokyo Bldg., 1-10, 1 Chome, Ueno, Taito-ku, TOKYO, 110-8534 JAPAN

STK621-061-E, 621-061A-E

Specifications

Absolute maximum ratings at $T_c = 25^\circ\text{C}$

Parameter	Symbol	Conditions	Ratings	Unit
Supply voltage	V_{CC}	+ - -, Surge < 500V *1	450	V
Collector-emitter voltage	V_{CE}	+ - U (V, W) or U (V, W) - -	600	V
Output current	I_O	+, -, U, V, W terminal current	± 30	A
Output peak current	I_{op}	+, -, U, V, W terminal current PW=100 μ s	± 45	A
Pre-driver supply voltage	$V_{D1, 2, 3, 4}$	VB1 - U, VB2 - V, VB3 - W, $V_{DD} - V_{SS}$ *2	20	V
Input signal voltage	V_{IN}	HIN1, 2, 3, LIN1, 2, 3 terminal	0 to 7	V
FAULT terminal voltage	VFAULT	FAULT terminal	20	V
Maximum loss	P_d	IGBT, Per 1 channel	49	W
Junction temperature	T_j	IGBT, FRD junction temperature	150	$^\circ\text{C}$
Storage temperature	T_{stg}		-40 to +125	$^\circ\text{C}$
Operating temperature	T_C	H-IC case temperature	-20 to +100	$^\circ\text{C}$
Tightening torque	MT	A screw part at use M4 type screw *3	1.17	N•m
Withstand voltage	Vis	50Hz sine wave AC 1 minute *4	2000	VRMS

In the case without the instruction, the voltage standard is - terminal = V_{SS} terminal voltage.

*1 Surge voltage developed by the switching operation due to the wiring inductance between the + and - terminals.

*2 V_{D1} = between VB1-U, V_{D2} =VB2-V, V_{D3} =VB3-W, V_{D4} = V_{DD} - V_{SS} , terminal voltage.

*3 Flatness of the heat-sink should be lower than 0.25mm.

*4 The test condition is AC 2500V, 1 second.

Electrical Characteristics at $T_c=25^\circ\text{C}$, $V_D=15\text{V}$

Parameters	Symbols	Conditions	min	typ	max	unit	Test circuit
Power output part							
Collector-to-emitter cut-off current	I_{CE}	$V_{CE}=600\text{V}$			0.5	mA	Fig.1
Boot-strap diode reverse current	I_R (BD)	V_R (BD)=600V			0.5	mA	Fig.1
Collector-to-emitter saturation voltage	V_{CE} (SAT)	$I_O=15\text{A}$	Upper side	1.9	2.7	V	Fig.2
			Lower side	2.1	2.9		
Diode forward voltage	VF	$I_O=-15\text{A}$	Upper side	1.7	2.5	V	Fig.3
			Lower side	1.9	2.7		
Junction-to-substrate thermal resistance	$\theta_{j-c}(T)$	IGBT		2.1		$^\circ\text{C/W}$	
	$\theta_{j-c}(D)$	FWD		2.5			
Control (Pre-driver) part							
Pre-drive power supply consumption electric current	I_D	$V_{D1, 2, 3}=15\text{V}$		0.07	0.4	mA	Fig.4
		$V_{D4}=15\text{V}$		3.3	7		
Input ON voltage	V_{IH}	Output ON			0.8	V	
Input OFF voltage	V_{IL}	Output OFF	3.0			V	
Protection part							
Excessive temperature	TSD	The substrate surface	100		120	$^\circ\text{C}$	
Overcurrent protection electric current	ISD	PW=100 μ s	45		59	A	Fig.5
Pre-drive low voltage protection	UVLO		10		12	V	
FAULT terminal input electric current	IOSD	VFAULT =0.1V		0.5		mA	
FAULT clearness delay time	FLTCLR	After each protection operation ending	18		80	ms	
Board temperature mounting resistance	R_t	Resistance between the FAULT and V_{SS} terminals	90		110	k Ω	
Switching time	tON	$I_O=15\text{A}$, Inductive load		0.8		μ s	Fig.6
	tOFF			1.3			
Electric current output signal level	ISO	$I_O=15\text{A}$		0.141		V	

In the case without the instruction, the voltage standard is - terminal = V_{SS} terminal voltage.

STK621-061-E, 621-061A-E

Notes

1. Input ON voltage indicates a value to turn on output stage IGBT.
Input OFF voltage indicates a value to turn off output stage IGBT.
At the time of output ON, set the input signal voltage 0V to V_{IH} (max).
At the time of output OFF, set the input signal voltage V_{IL} (min) to 5V.
2. When the internal protection circuit operates, there is a FAULT signal ON (When the FAULT terminal is low level, FAULT signal is ON state: output form is open DRAIN) but the FAULT signal doesn't latch.
After protection operation ends, it returns automatically within about 18ms to 80ms and resumes operation beginning condition. So, after FAULT signal detection, set OFF (HIGH) to all input signals at once.
However, the operation of pre-drive power supply low voltage protection (UVLO: it has a hysteresis about 0.3V) is as follows.
Upper side → There is no FAULT signal output, but it does a corresponding gate signal OFF.
Incidentally, it returns to the regular operation when recovering to the normal voltage, but the latch continues among input signal ON (low).
Lower side → It outputs FAULT signal with gate signal OFF.
However, it is different from the protection operation of upper side, it is automatically resets about 18ms to 80ms later and resumes operation beginning condition when recovering to normal voltage.
(The protection operation doesn't latch by the input signal.)
3. When assembling the hybrid IC on the heat sink with M4 type screw, tightening torque range is 0.79N•m to 1.17N•m.
Flatness of the heat-sink should be lower than 0.25mm.
4. The pre-drive low voltage protection is the feature to protect a device when the pre-driver supply voltage declines with the operating malfunction. As for the pre-driver supply voltage decline in case of operation beginning, and so on, we request confirmation in the set.

Package Dimensions

unit:mm (typ)

[STK621-061-E]

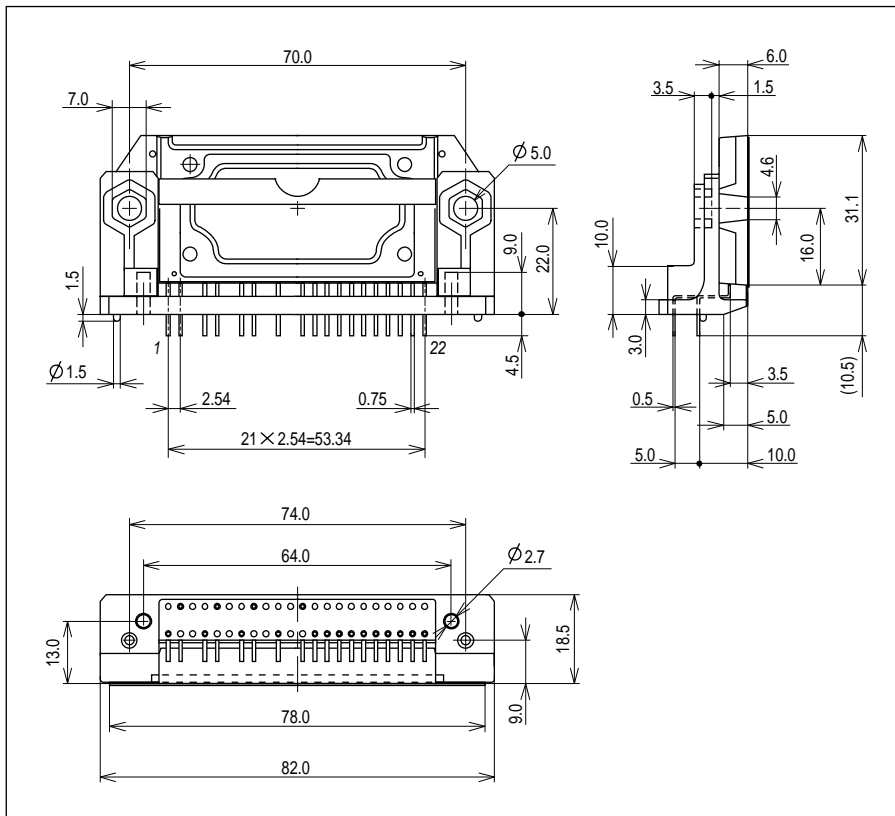

STK621-061-E, 621-061A-E

Package Dimensions

unit:mm (typ)

[STK621-061A-E]

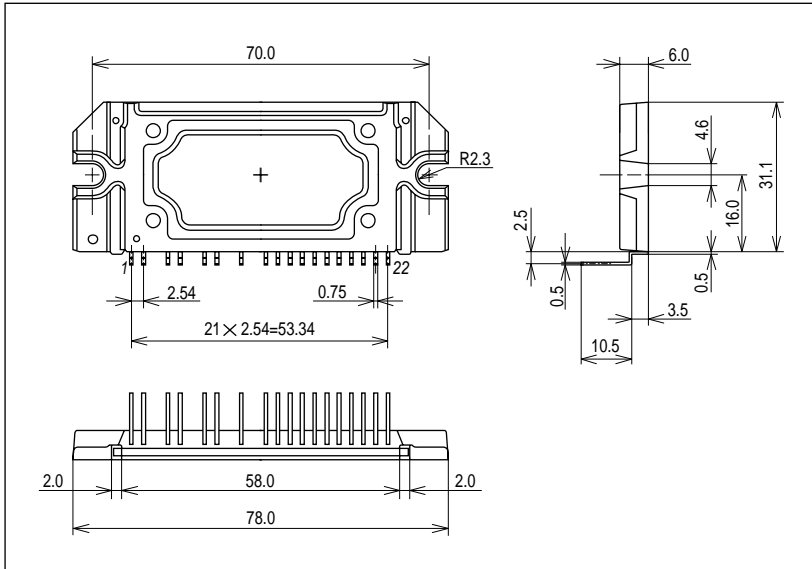

Internal Equivalent Circuit Diagram

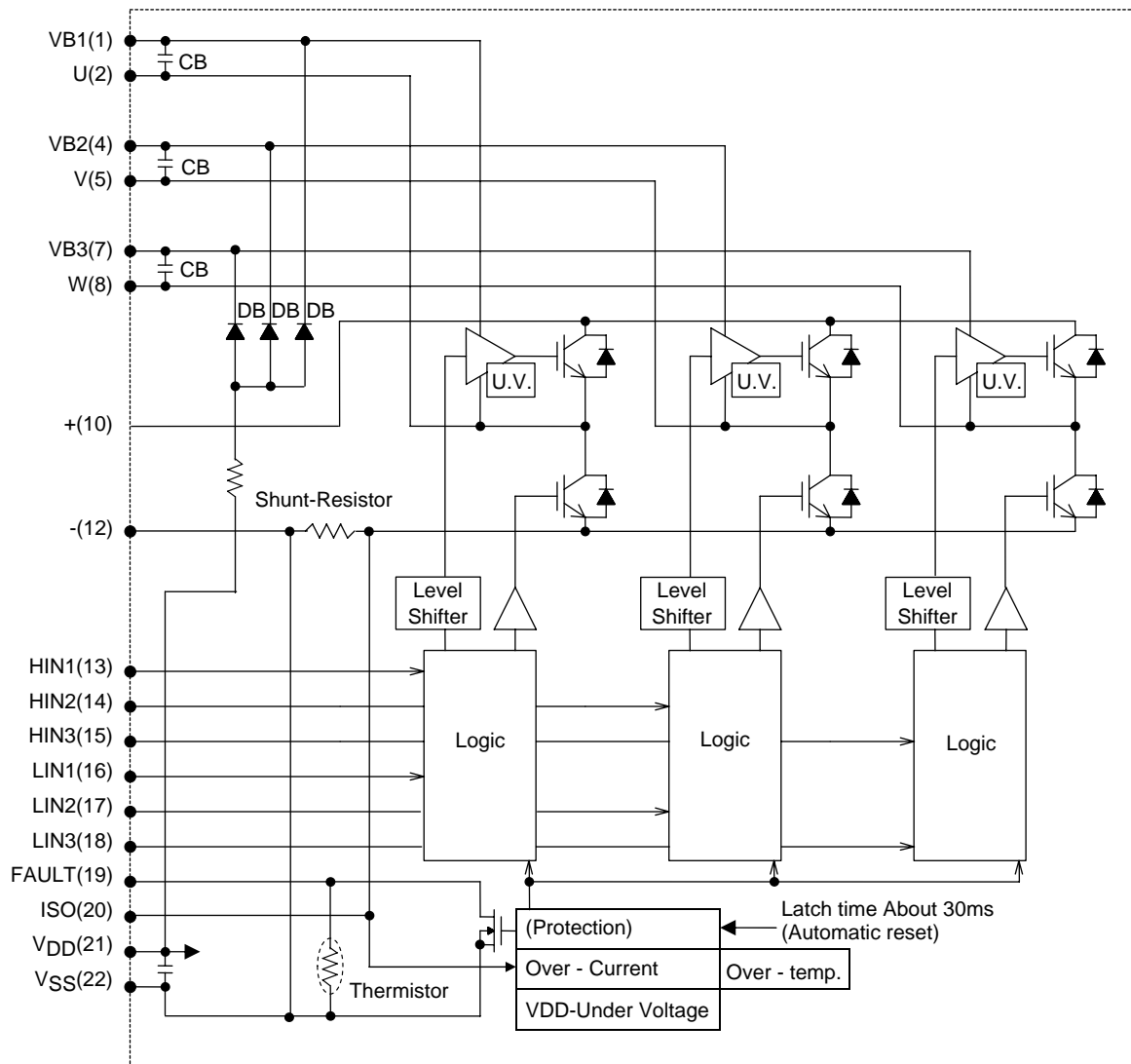

Test Circuit

1: ICE

	U+	V+	W+	U-	V-	W-
M	10	10	10	2	5	8
N	2	5	8	12	12	12

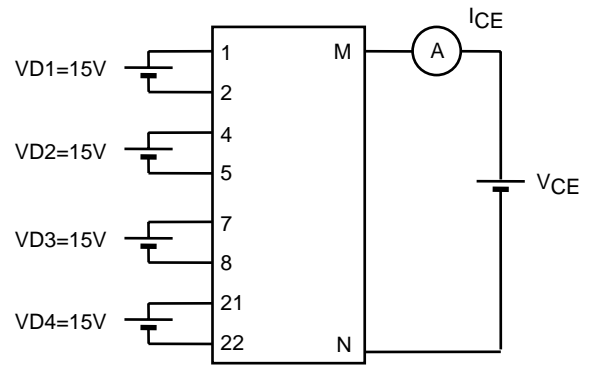

2: VCE (SAT)

	U+	V+	W+	U-	V-	W-
M	10	10	10	2	5	8
N	2	5	8	12	12	12
m	13	14	15	16	17	18

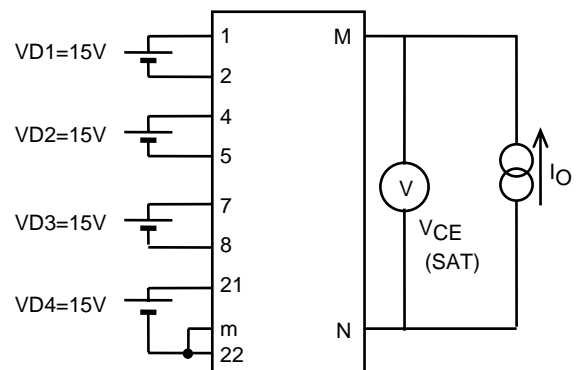

3: VF

	U+	V+	W+	U-	V-	W-
M	10	10	10	2	5	8
N	2	5	8	12	12	12

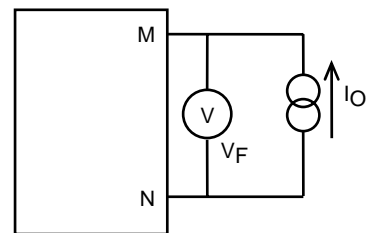

4: ID

	VD1	VD2	VD3	VD4
m	1	4	7	21
n	2	5	8	22

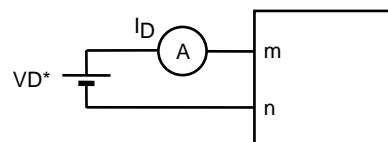

STK621-061-E, 621-061A-E

5: ISD

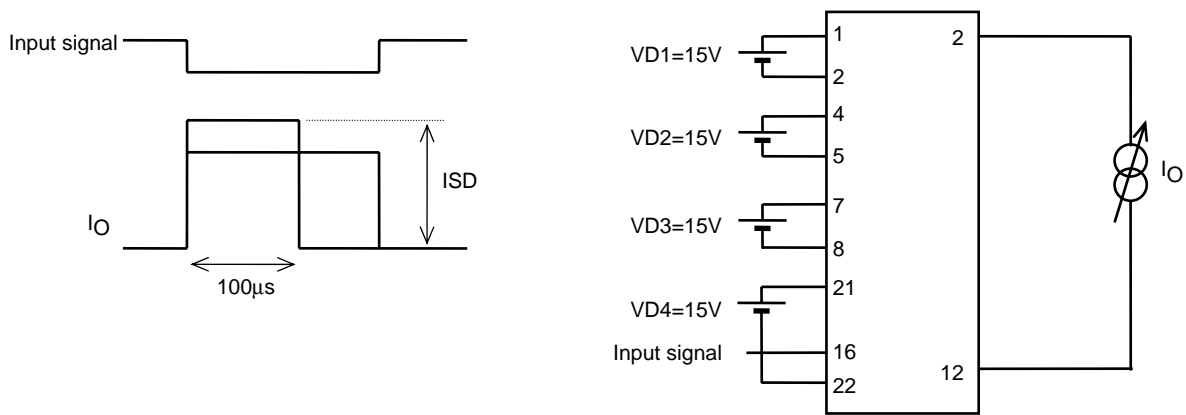

6: Switching time

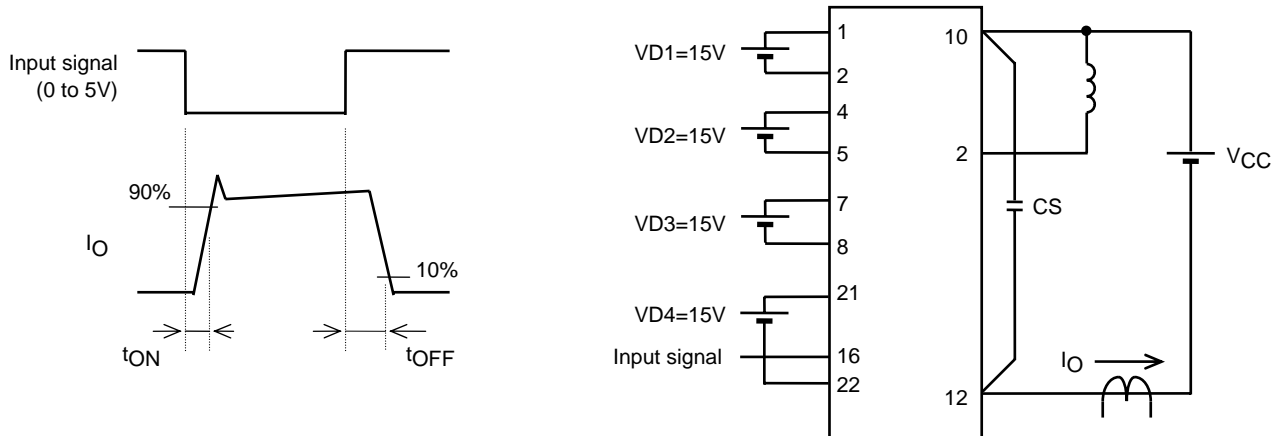

Example of The Application Circuit

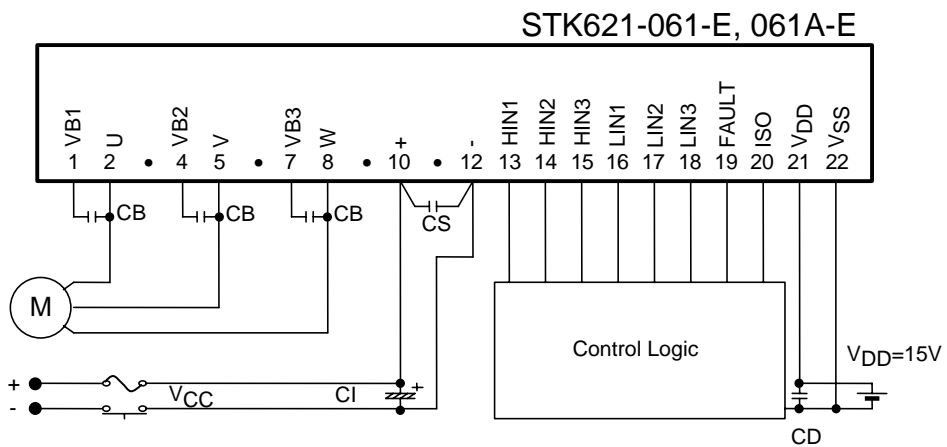

Recommended Operating Conditions

Parameters	Symbol	Conditions	min	typ	max	unit
Supply voltage	V _{CC}	+ - -	0	280	400	V
Pre-driver supply voltage	VD1, 2, 3	VB1-U, VB2-V, VB3-W	12.5	15	17.5	V
	VD4	V _{DD} -V _{SS} *1	13.5	15	16.5	
ON input signal voltage	V _{IN} (ON)	HIN1, HIN2, HIN3, LIN1, LIN2, LIN3-V _{SS}	0		0.3	V
OFF input signal voltage	V _{IN} (OFF)	terminal	3.5		5	V
PWM frequency	f _{PWM}		1		20	kHz
Dead time	DT	Upper/lower input signal downtime	2			μs
Tightening torque	MT	'M4' type screw	0.79		1.17	N•m

*1 Pre-driver power supply (VD4=15±1.5V) must have the capacity of I_O=20mA (DC), 0.5A (Peak).

Precautions

1. A control power supply can be driven with one power supply by attaching the capacitor CB (1 to max47μF) for a bootstrap. In this case, a bottom element is made to charge.
(When not using bootstrap circuit, each upper side pre-drive power supply needs an independent power supply. Externally set.)
In addition, please carry out capacity of the capacitor for a bootstrap (external) to 47μF (±20%). When 47μF (±20%) or more are connected, Please connect resistance (about 20Ω) also with 3-phase at series between each top power supply terminal (VB1, 2, and 3) and the capacitor for a bootstrap. Moreover, since top power supply voltage may be insufficient depending on the control method, Please carry out a check with the system.
2. Because the jump voltage which is accompanied by the vibration in case of switching operation occurs by the influence of the floating inductance of the wiring of the outer power supply which is connected with of the + terminal and the - terminal, restrains and spares serge voltage being as the connection of the snubber circuit (Capacitor / CS / about 0.22 to 10μF) for the voltage absorption with the neighborhood as possible between + and the - terminal, and so on, with making a wiring length (among the terminals each from CI) short and making a wiring inductance small.
3. ISO terminal (20pin) is for the electric current monitor. When the pull up with the resistance, use above 5.6kΩ Be careful, because the over current protection does not operate when short-circuiting in the ISO terminal and the V_{SS} terminal.
4. Output form of the FAULT terminal is open DRAIN (it is operating as FAULT when becoming low).
The STK621-061-E and STK621-061A-E has abuilt-in thermistor between the FAULT and V_{SS} terminals. It allows monitoring of the board temperature using the divided voltage developed with the pull-up resistance RP.
Theresistance of the RP must be 10kΩ or higher at a pull-up voltage of 5V and 39kΩ or higher at pull-up voltage of 15V
5. Zener diode with 5V (5.0 to 5.4V) is connected with the inside of the signal input terminal. When inputting the voltage which exceeds 5V, connect resistor to between the side of the power and the signal input terminal, for the input current of the signal input terminal become equal to or less than 0.5mA.
This resistor is effective with the noise absorption of the signal terminal, too.
6. The over current protection feature operates only when it is possible to do a circuit control normally. For the safety, put a fuse, and so on in the V_{CC} line.
7. Because the IC sometimes destroys and bursts when motor connection terminal (2pin, 5pin, 8pin) becomes open while the motor turns, especially, be careful of the connection (the soldering condition) of this terminal.
8. If - terminal and V_{SS} terminal are short-circuited, since an over-current protection (ISD) value will become lower than the inside setting value of HIC, please do not connect externally.
(- terminal and V_{SS} terminal are connected inside HIC)

* This data shows the example of the application circuit, does not guarantee a design as the mass production set.

- SANYO Semiconductor Co.,Ltd. assumes no responsibility for equipment failures that result from using products at values that exceed, even momentarily, rated values (such as maximum ratings, operating condition ranges, or other parameters) listed in products specifications of any and all SANYO Semiconductor Co.,Ltd. products described or contained herein.
- SANYO Semiconductor Co.,Ltd. strives to supply high-quality high-reliability products, however, any and all semiconductor products fail or malfunction with some probability. It is possible that these probabilistic failures or malfunction could give rise to accidents or events that could endanger human lives, trouble that could give rise to smoke or fire, or accidents that could cause damage to other property. When designing equipment, adopt safety measures so that these kinds of accidents or events cannot occur. Such measures include but are not limited to protective circuits and error prevention circuits for safe design, redundant design, and structural design.
- In the event that any or all SANYO Semiconductor Co.,Ltd. products described or contained herein are controlled under any of applicable local export control laws and regulations, such products may require the export license from the authorities concerned in accordance with the above law.
- No part of this publication may be reproduced or transmitted in any form or by any means, electronic or mechanical, including photocopying and recording, or any information storage or retrieval system, or otherwise, without the prior written consent of SANYO Semiconductor Co.,Ltd.
- Any and all information described or contained herein are subject to change without notice due to product/technology improvement, etc. When designing equipment, refer to the "Delivery Specification" for the SANYO Semiconductor Co.,Ltd. product that you intend to use.
- Information (including circuit diagrams and circuit parameters) herein is for example only; it is not guaranteed for volume production.
- Upon using the technical information or products described herein, neither warranty nor license shall be granted with regard to intellectual property rights or any other rights of SANYO Semiconductor Co.,Ltd. or any third party. SANYO Semiconductor Co.,Ltd. shall not be liable for any claim or suits with regard to a third party's intellectual property rights which has resulted from the use of the technical information and products mentioned above.

This catalog provides information as of June, 2008. Specifications and information herein are subject to change without notice.