

High Speed, Quad SPST, CMOS Analog Switch

August 1997

Features

- **Fast Switching Times**
 - t_{ON} 30ns
 - t_{OFF} 40ns
- **Low "ON" Resistance** 30 Ω
- **Pin Compatible with Standard HI-201**
- **Wide Analog Voltage Range ($\pm 15V$ Supplies)** $\pm 15V$
- **Low Charge Injection ($\pm 15V$ Supplies)** 10pC
- **TTL Compatible**
- **Symmetrical Switching Analog Current Range** .. 80mA

Applications

- High Speed Multiplexing
- High Frequency Analog Switching
- Sample and Hold Circuits
- Digital Filters
- Operational Amplifier Gain Switching Networks
- Integrator Reset Circuits

Description

The HI-201HS is a monolithic CMOS Analog Switch featuring very fast switching speeds and low ON resistance. The integrated circuit consists of four independently selectable SPST switches and is pin compatible with the industry standard HI-201 switch.

Fabricated using silicon-gate technology and the Harris Dielectric Isolation process, this TTL compatible device offers improved performance over previously available CMOS analog switches. Featuring maximum switching times of 50ns, low ON resistance of 50 Ω maximum, and a wide analog signal range, the HI-201HS is designed for any application where improved switching performance, particularly switching speed, is required. (A more detailed discussion on the design and application of the HI-201HS can be found in Application Note AN543.)

Ordering Information

PART NUMBER	TEMP. RANGE (°C)	PACKAGE	PKG. NO.
HI1-0201HS-5	0 to 75	16 Ld CERDIP	F16.3
HI3-0201HS-4	-25 to 85	16 Ld PDIP	E16.3
HI1-0201HS-2	-55 to 125	16 Ld CERDIP	F16.3
HI1-0201HS-4	-25 to 85	16 Ld CERDIP	F16.3
HI4P0201HS-5	0 to 75	20 Ld PLCC	N20.35
HI3-0201HS-5	0 to 75	16 Ld PDIP	E16.3
HI1-0201HS-7	0 to 75	16 Ld CERDIP	F16.3
HI4-0201HS/883	-55 to 125	20 Ld CLCC	J20.A
HI9P0201HS-5	0 to 75	16 Ld SOIC	M16.3
HI9P0201HS-9	-40 to 85	16 Ld SOIC	M16.3
HI1-0201HS/883	-55 to 125	16 Ld CERDIP	F16.3
HI1-0201HS-8	-55 to 125	16 Ld CERDIP	F16.3

Functional Diagram

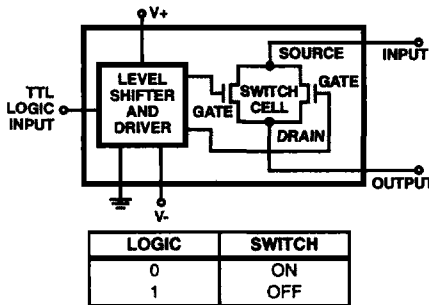

Pinouts

HI-201HS (CERDIP, PDIP, SOIC)
TOP VIEW

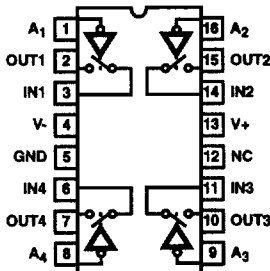

HI201HS (CLCC)
TOP VIEW

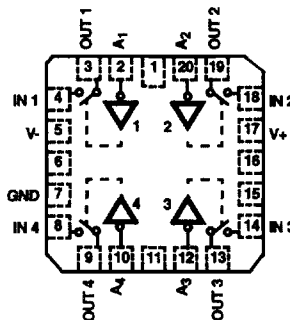

HI201HS (PLCC)
TOP VIEW

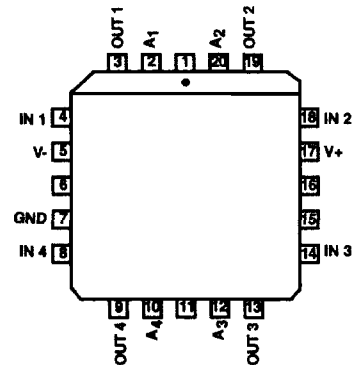

Schematic Diagrams

TTL/CMOS REFERENCE CIRCUIT

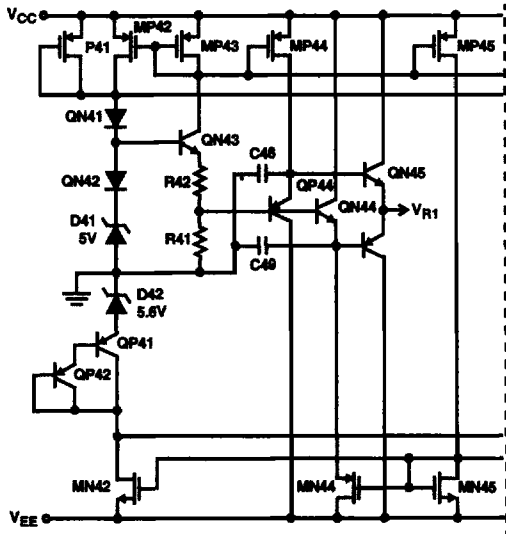

SWITCH CELL

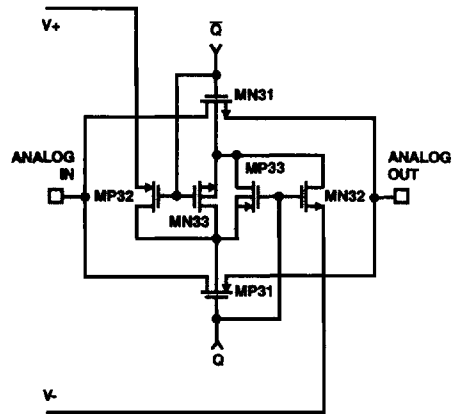

DIGITAL INPUT BUFFER AND LEVEL SHIFTER

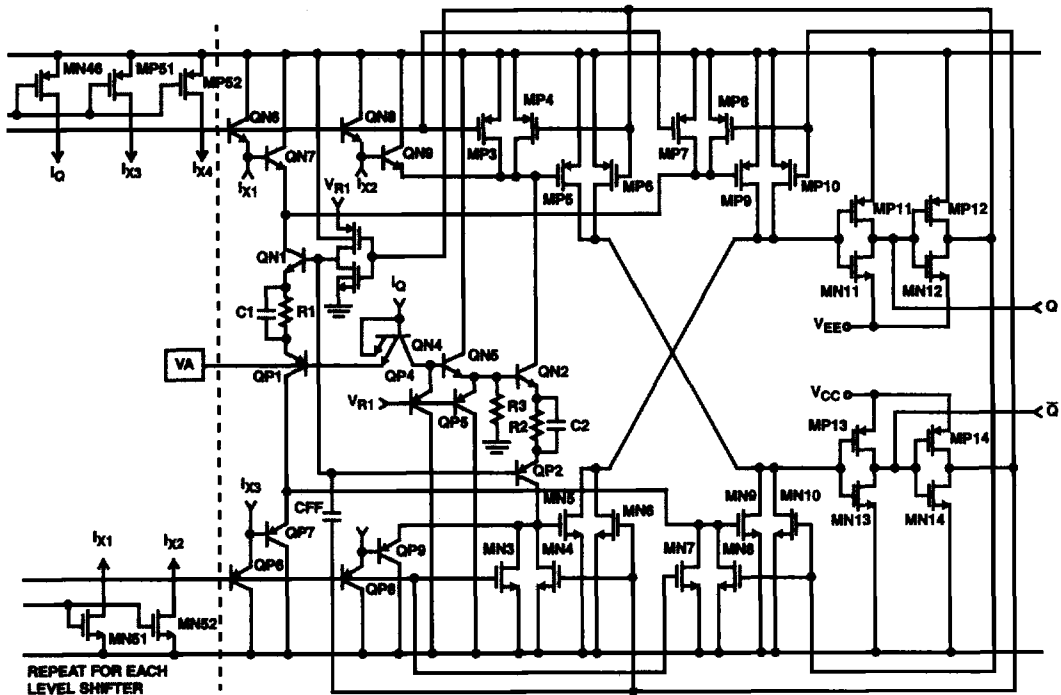

HI-201HS

Absolute Maximum Ratings

Supply Voltage (Between Pins 4 and 13)	36V
Digital Input Voltage (Pins 1, 8, 9, 16)	(V+) +4V, (V-) -4V
Analog Input Voltage (One Switch)	(V+) +2.0V
Pins 2, 3, 6, 7, 10, 11, 14, 15	(V-) -2.0V
Peak Current (S or D) (Pulse at 1ms, 10% Duty Cycle Max)	50mA
Continuous Current Any Terminal (Except S or D)	25mA

Thermal Information

Thermal Resistance (Typical, Note 1)	θ_{JA} (°C/W)	θ_{JC} (°C/W)
CERDIP Package	80	30
CLCC Package	65	14
PDIP Package	100	N/A
PLCC Package	80	N/A
SOIC Package	100	N/A

Operating Conditions

Temperature Ranges	
HI-201HS-2,-8	-55°C to 125°C
HI-201HS-4	-25°C to 85°C
HI-201HS-5,-7	0°C to 75°C
HI-201HS-9	-40°C to 85°C

Maximum Junction Temperature	
Ceramic Package	175°C
Plastic Package	150°C
Maximum Storage Temperature	-65°C to 150°C
Maximum Lead Temperature (Soldering 10s)	300°C
(SOIC, PLCC - Lead Tips Only)	

CAUTION: Stresses above those listed in "Absolute Maximum Ratings" may cause permanent damage to the device. This is a stress only rating and operation of the device at these or any other conditions above those indicated in the operational sections of this specification is not implied.

NOTE:

- θ_{JA} is measured with the component mounted on an evaluation PC board in free air.

Electrical Specifications Supplies = +15V, -15V; V_{AH} (Logic Level High) = 2.4V, V_{AL} (Logic Level Low) = +0.8V, GND = 0V, Unless Otherwise Specified

PARAMETER	TEST CONDITIONS	TEMP (°C)	HI-201HS-2/-8			HI-201HS-5/-4/-9/-7			UNITS
			MIN	TYP	MAX	MIN	TYP	MAX	
SWITCHING CHARACTERISTICS									
t_{ON} , Switch On Time	(Note 3)	25	-	30	50	-	30	50	ns
t_{OFF1} , Switch Off Time	(Note 3)	25	-	40	50	-	40	50	ns
t_{OFF2} , Switch Off Time	(Note 3)	25	-	150	-	-	150	-	ns
Output Settling Time 0.1%		25	-	180	-	-	180	-	ns
"Off Isolation"	(Note 4)	25	-	72	-	-	72	-	dB
Crosstalk	(Note 5)	25	-	86	-	-	86	-	dB
Charge Injection	(Note 6)	25	-	10	-	-	10	-	pC
$C_{S(OFF)}$, Input Switch Capacitance		25	-	10	-	-	10	-	pF
$C_{D(OFF)}$, } Output Switch Capacitance		25	-	10	-	-	10	-	pF
	$C_{D(ON)}$, }	25	-	30	-	-	30	-	pF
C_A , Digital Input Capacitance		25	-	18	-	-	18	-	pF
$C_{DS(OFF)}$, Drain-To-Source Capacitance		25	-	0.5	-	-	0.5	-	pF
DIGITAL INPUT CHARACTERISTICS									
V_{AL} , Input Low Threshold		Full	-	-	0.8	-	-	0.8	V
V_{AH} , Input High Threshold		25	2.0	-	-	2.0	-	-	V
		Full	2.4	-	-	2.4	-	-	V
I_{AL} , Input Leakage Current (Low)		25	-	-200	-	-	-200	-	μA
		Full	-	-	-500	-	-	-500	μA
I_{AH} , Input Leakage Current (High)	$V_{AH} = 4.0V$	25	-	20	-	-	20	-	μA
	Full		-	-	+40	-	-	+40	μA
ANALOG SWITCH CHARACTERISTICS									
V_S , Analog Signal Range		Full	-15	-	+15	-15	-	+15	V
r_{ON} , On Resistance	(Note 2)	25	-	30	50	-	30	50	Ω
		Full	-	-	75	-	-	75	Ω
r_{ON} , Match		25	-	3	-	-	3	-	%

Electrical Specifications Supplies = +15V, -15V; V_{AH} (Logic Level High) = 2.4V, V_{AL} (Logic Level Low) = +0.8V, GND = 0V, Unless Otherwise Specified (Continued)

PARAMETER	TEST CONDITIONS	TEMP (°C)	HI-201HS-2/-8			HI-201HS-5/-4/-9/-7			UNITS
			MIN	TYP	MAX	MIN	TYP	MAX	
$I_{S(OFF)}$, Off Input Leakage Current		25	-	0.3	10	-	0.3	10	nA
		Full	-	-	100	-	-	50	nA
$I_{D(OFF)}$, Off Output Leakage Current		25	-	0.3	10	-	0.3	10	nA
		Full	-	-	100	-	-	50	nA
$I_{D(ON)}$, On Leakage Current		25	-	0.1	10	-	0.1	10	nA
		Full	-	-	100	-	-	50	nA
POWER SUPPLY CHARACTERISTICS (Note 7)									
P_D , Power Dissipation		25	-	120	-	-	120	-	mW
		Full	-	-	240	-	-	240	mW
I_+ , Current (Pin 13)		25	-	4.5	-	-	4.5	-	mA
		Full	-	-	10.0	-	-	10.0	mA
I_- , Current (Pin 4)		25	-	3.5	-	-	3.5	-	mA
		Full	-	-	6	-	-	6	mA

NOTES:

1. Absolute maximum ratings are limiting values, applied individually, beyond which the serviceability of the circuit may be impaired. Functional operability under any of these conditions is not necessarily implied.
2. $V_{OUT} = \pm 10V$, $I_{OUT} = 1mA$.
3. $R_L = 1k\Omega$, $C_L = 35pF$, $V_{IN} = +10V$, $V_A = +3V$. (See Switching Waveforms).
4. $V_A = 3V$, $R_L = 1k\Omega$, $C_L = 10pF$, $V_{IN} = 3V_{RMS}$, $f = 100kHz$.
5. $V_A = 3V$, $R_L = 1k\Omega$, $V_{IN} = 3V_{RMS}$, $f = 100kHz$.
6. $C_L = 1000pF$, $V_{IN} = 0V$, $R_{IN} = 0V$, $\Delta Q = C_L \times \Delta V_O$.
7. $V_A = 3V$ or $V_A = 0$ for all switches.

Switching Waveforms

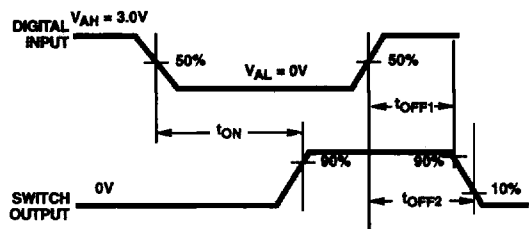
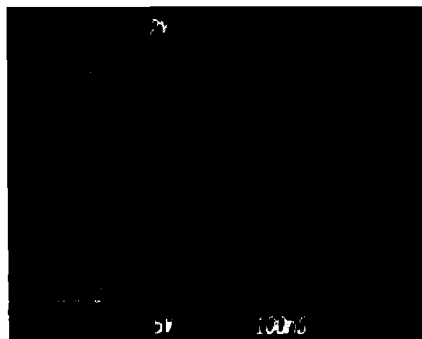

FIGURE 1A.



TOP: TTL Input (2V/Div.) BOTTOM: Output (5V/Div.)
HORIZONTAL: 100ns/Div.

FIGURE 1B.

FIGURE 1. SWITCH t_{ON} AND t_{OFF} TIMES

Typical Performance Curves

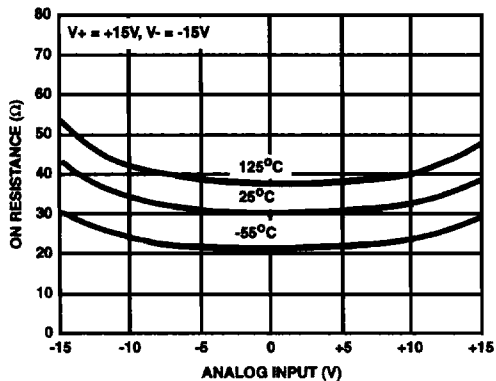

FIGURE 2. "ON" RESISTANCE vs ANALOG SIGNAL LEVEL AND TEMPERATURE

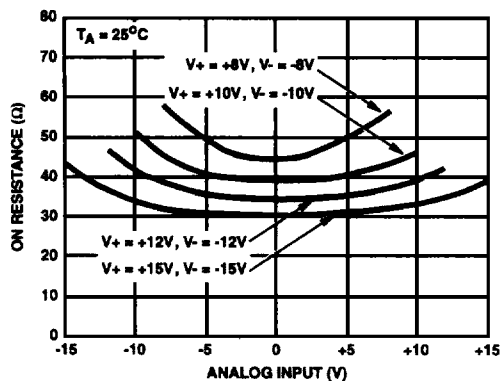

FIGURE 3. "ON" RESISTANCE vs ANALOG SIGNAL LEVEL AND POWER SUPPLY VOLTAGE

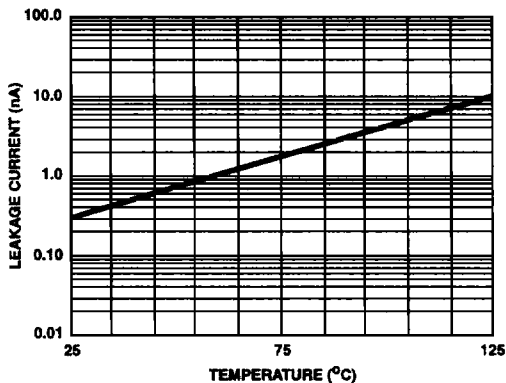

FIGURE 4. $I_{S(OFF)}$ OR $I_{D(OFF)}$ vs TEMPERATURE†

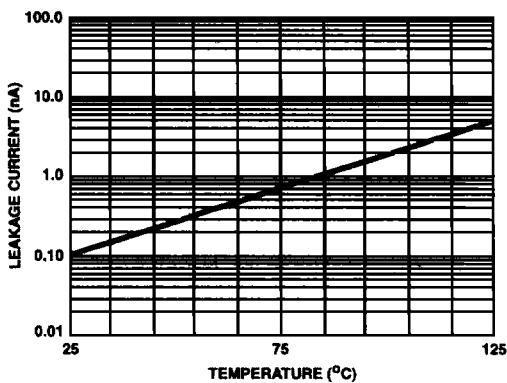

FIGURE 5. $I_{D(ON)}$ vs TEMPERATURE†

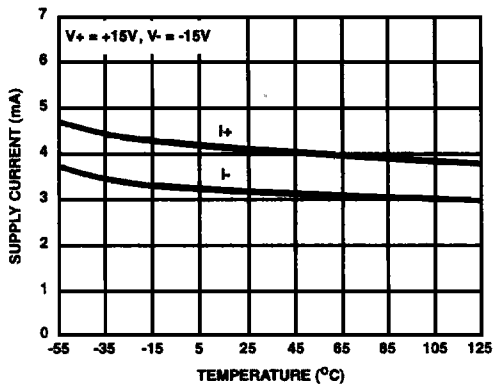

FIGURE 6. SUPPLY CURRENT vs TEMPERATURE

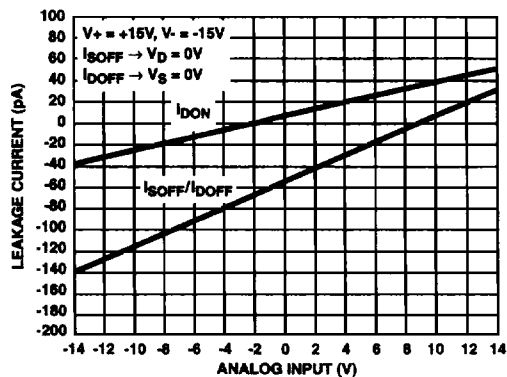

FIGURE 7. LEAKAGE CURRENT vs ANALOG INPUT VOLTAGE

† Theoretically, leakage current will continue to decrease below 25°C. But due to environmental conditions, leakage measurements below this temperature are not representative of actual switch performance.

Typical Performance Curves (Continued)

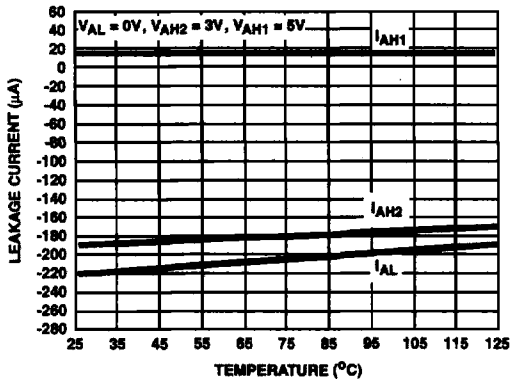

FIGURE 8. DIGITAL INPUT LEAKAGE CURRENT vs TEMPERATURE†

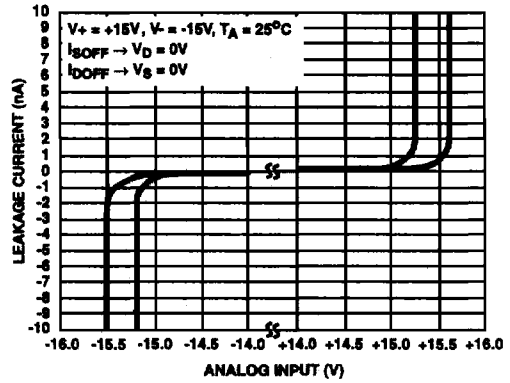

FIGURE 9. LEAKAGE CURRENT vs ANALOG INPUT VOLTAGE

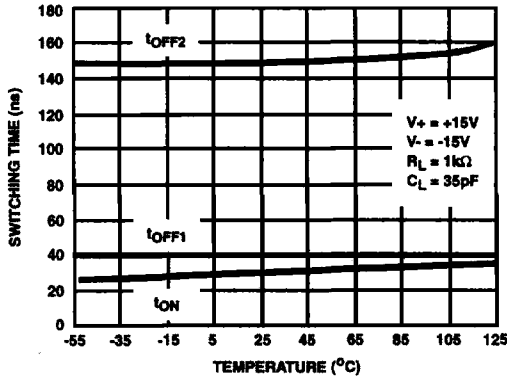

FIGURE 10. SWITCHING TIME vs TEMPERATURE

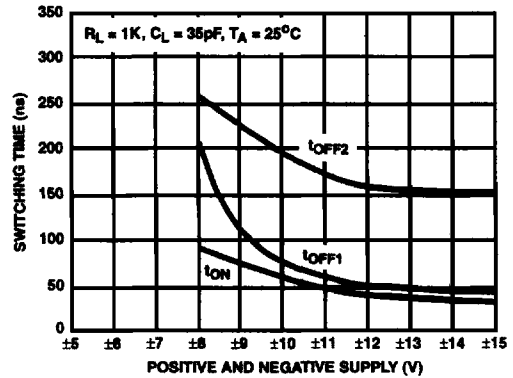

FIGURE 11. SWITCHING TIME vs POSITIVE AND NEGATIVE SUPPLY VOLTAGE

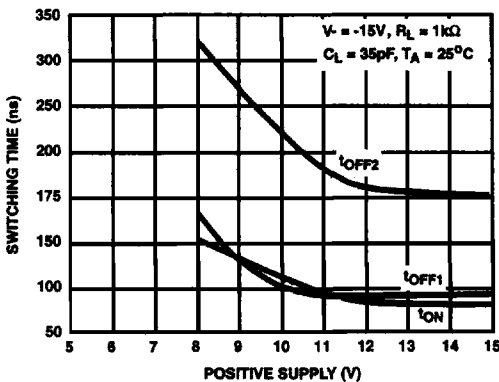

FIGURE 12. SWITCHING TIME vs POSITIVE SUPPLY VOLTAGE

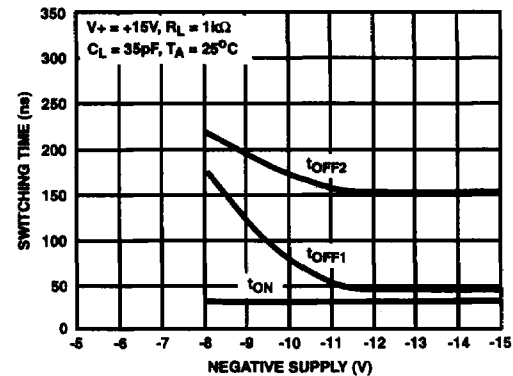

FIGURE 13. SWITCHING TIME vs NEGATIVE SUPPLY VOLTAGE

† Theoretically, leakage current will continue to decrease below 25°C. But due to environmental conditions, leakage measurements below this temperature are not representative of actual switch performance.

Typical Performance Curves (Continued)

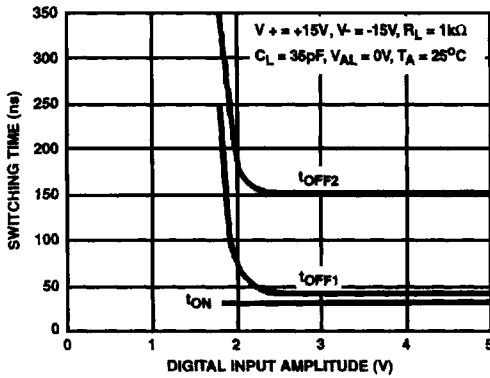

FIGURE 14. SWITCHING TIME vs INPUT LOGIC AMPLITUDE

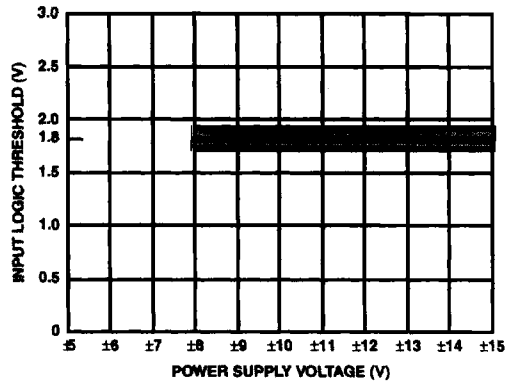

FIGURE 15. INPUT SWITCHING THRESHOLD vs POSITIVE AND NEGATIVE SUPPLY VOLTAGES

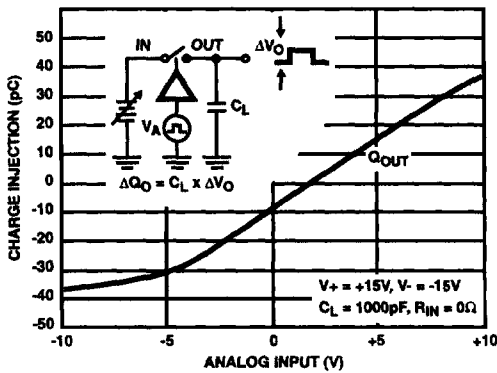

FIGURE 16. CHARGE INJECTION vs ANALOG INPUT

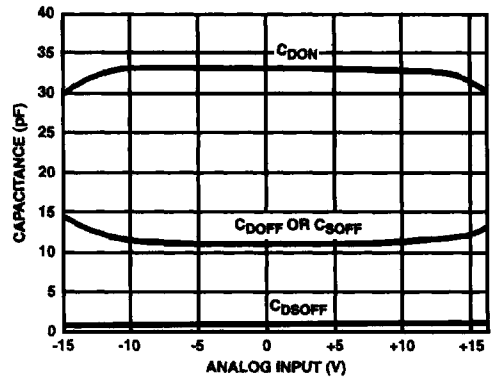

FIGURE 17. CAPACITANCE vs ANALOG INPUT

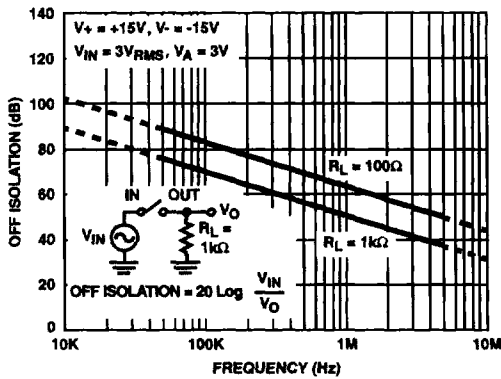

FIGURE 18. OFF ISOLATION vs FREQUENCY

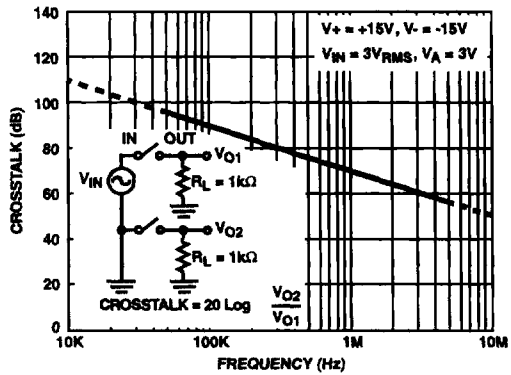

FIGURE 19. CROSSTALK vs FREQUENCY

Test Circuit

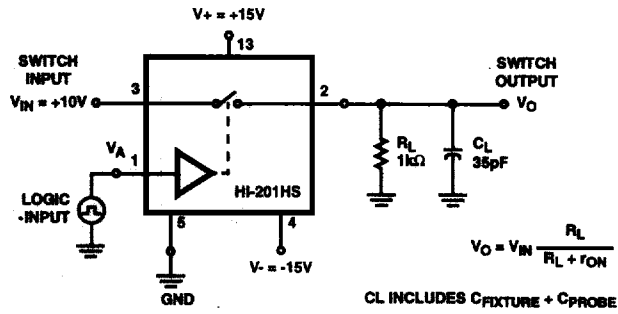

FIGURE 20. SWITCHING TEST CIRCUIT (t_{ON} , t_{OFF1} , t_{OFF2})

Switching Characteristics

Typical delay, t_{ON} , t_{OFF} , settling time and switching transients in this circuit. If R_L or C_L is increased, there will be corresponding increases in rise and/or fall RC times.

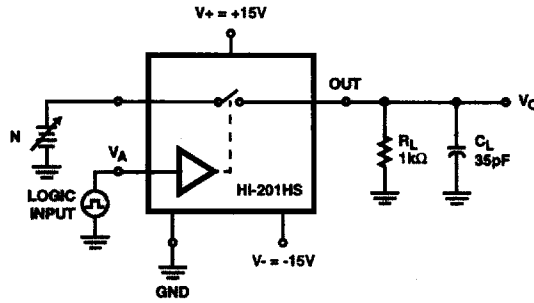

FIGURE 21A.

LOGIC INPUT



FIGURE 21B.

FIGURE 21. SWITCHING CHARACTERISTICS vs INPUT VOLTAGE

Switching Characteristics (Continued)

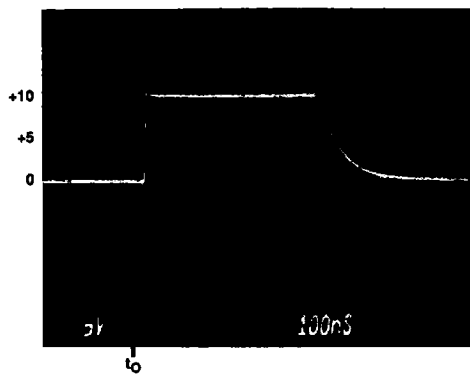

FIGURE 22A. $V_{IN} = +10V$

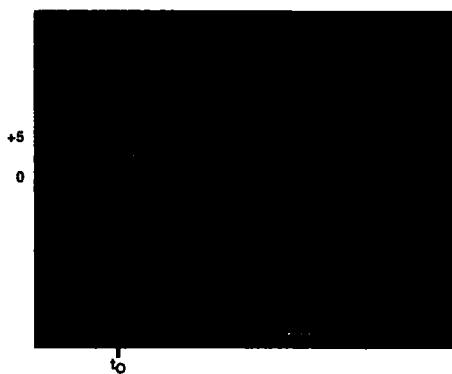

FIGURE 22B. $V_{IN} = +5V$

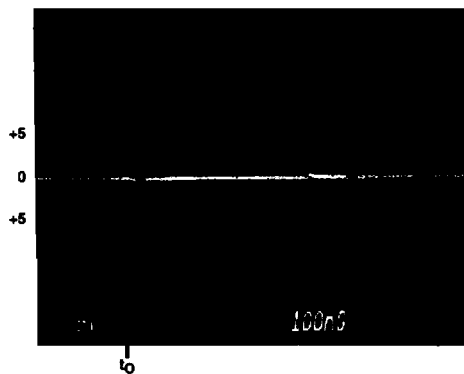

FIGURE 22C. $V_{IN} = 0V$

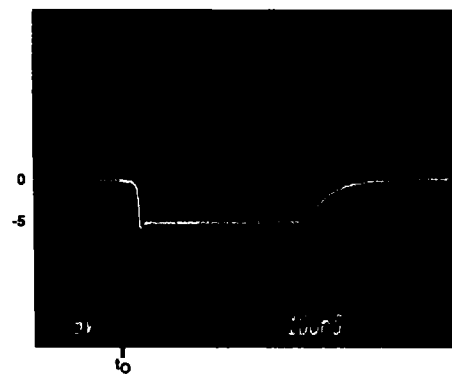

FIGURE 22D. $V_{IN} = -5V$



FIGURE 22E. $V_{IN} = -10V$

FIGURE 22. V_O - OUTPUT SWITCHING WAVEFORMS

Application Information

Logic Compatibility

The HI-201HS is TTL compatible. Its logic inputs (pins 1, 8, 9, and 16) are designed to react to digital inputs which exceed a fixed, internally generated TTL switching threshold. The HI-201HS can also be driven with CMOS logic (0V-15V), although the switch performance with CMOS logic will be inferior to that with TTL logic (0V-5V).

The logic input design of the HI-201HS is largely responsible for its fast switching speed. It is a design which features a unique input stage consisting of complementary vertical PNP and NPN bipolar transistors. This design differs from that of the standard HI-201 product where the logic inputs are MOS transistors.

Although the new logic design enhances the switching speed performance, it also increases the logic input leakage currents. Therefore, the HI-201HS will exhibit larger digital input leakage currents in comparison to the standard HI-201 product.

Charge Injection

Charge injection is the charge transferred, through the internal gate-to-channel capacitances, from the digital logic input to the analog output. To optimize charge injection performance for the HI-201HS, it is advisable to provide a TTL logic input with fast rise and fall times.

If the power supplies are reduced from $\pm 15V$, charge injection will become increasingly dependent upon the digital input frequency. Increased logic input frequency will result in larger output error due to charge injection.

Power Supply Considerations

The electrical characteristics specified in this data sheet are guaranteed for power supplies $\pm V_S = \pm 15V$. Power supply voltages less than $\pm 15V$ will result in reduced switch performance. The following information is intended as a design aid only.

POWER SUPPLY VOLTAGES	SWITCH PERFORMANCE
$\pm 12 < \pm V_S \pm 15V$	Minimal Variation
$\pm V_S < \pm 12V$	Parametric variation becomes increasingly large (Increased ON resistance, longer switching times).
$\pm V_S < \pm 10V$	Not Recommended.
$\pm V_S > \pm 16V$	Not Recommended.

Single Supply

The switch operation of the HI-201HS is dependent upon an internally generated switching threshold voltage optimized for $\pm 15V$ power supplies. The HI-201HS does not provide the necessary internal switching threshold in a single supply system. Therefore, if single supply operation is required, the HI-300 series of switches is recommended. The HI-300 series will remain operational to a minimum +5V single supply.

Switch performance will degrade as power supply voltage is reduced from optimum levels ($\pm 15V$). So it is recommended that a single supply design be thoroughly evaluated to ensure that the switch will meet the requirements of the application.

For Further Information See Application Notes AN520, AN521, AN531, AN532, AN543 and AN557.

HI-201HS

Die Characteristics

DIE DIMENSIONS:

2440 μm x 2860 μm x 485 μm \pm 25 μm

METALLIZATION:

Type: CuAl

Thickness: 16k \AA \pm 2k \AA

PASSIVATION:

Type: Nitride Over Silox

Nitride Thickness: 3.5k \AA \pm 1k \AA

Silox Thickness: 12k \AA \pm 2k \AA

WORST CASE CURRENT DENSITY:

9.5 x 10⁴ A/cm²

Metallization Mask Layout

HI-201HS

