

March 1993

FM IF System

### Features

- For FM IF Amplifier Applications in High-Fidelity, Automotive, and Communications Receivers
- Includes: IF Amplifier, Quadrature Detector, AF Preamp, and Specific Circuits for AGC, AFC, Muting (Squelch), and Tuning Meter
- Exceptional Limiting Sensitivity..... 12 $\mu$ V (Typ.) at -3dB Point
- Low Distortion: .....(with Double-Tuned Coil) - 0.1% (Typ.)
- Single-Coil Tuning Capability
- High Recovered Audio.....400mV (Typ.)
- Provides Specific Signal for Control of Interchannel Muting (Squelch)
- Provides Specific Signal for Direct Drive of a Tuning Meter
- Provides Delayed AGC Voltage for RF Amplifier
- Provides a Specific Circuit for Flexible AFC
- Internal Supply-Voltage Regulators

### Description

Harris CA3089 is a monolithic integrated circuit that provides all the functions of a comprehensive FM-IF system. The block diagram shows the CA3089 features, which include a three-stage FM-IF amplifier/limiter configuration with level detectors for each stage, a doubly-balanced quadrature FM detector and an audio amplifier that features the optional use of a muting (squelch) circuit.

The advanced circuit design of the IF system includes desirable deluxe features such as delayed AGC for the RF tuner, and AFC drive circuit, and an output signal to drive a tuning meter and/or provide stereo switching logic. In addition, internal power supply regulators maintain a nearly constant current drain over the voltage supply range of +8.5V to +16 V.

The CA3089 is ideal for high-fidelity operation. Distortion in a CA3089 FM-IF System is primarily a function of the phase linearity characteristic of the outboard detector coil.

### Ordering Information

PART NUMBER	TEMPERATURE RANGE	PACKAGE
CA3089E	-40°C to +85°C	16 Lead Plastic DIP
CA3089F	-40°C to +85°C	16 Lead Ceramic DIP
CA3089M1	-40°C to +85°C	20 Lead SOIC

### Pinouts

CA3089  
(PDIP, CDIP)  
TOP VIEW

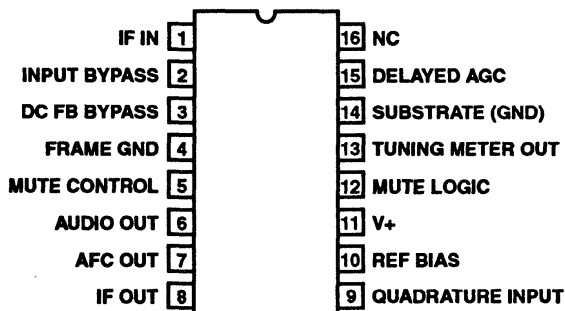

CA3089  
(SOIC)  
TOP VIEW

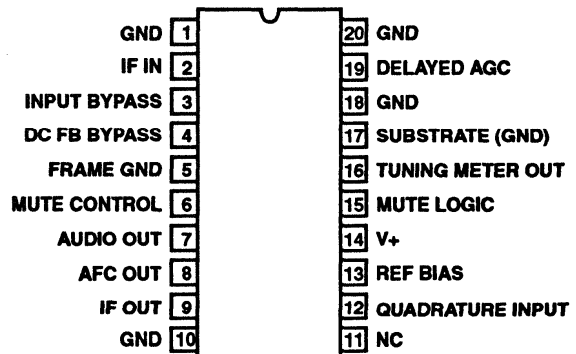

## Specifications CA3089

### Absolute Maximum Ratings

Supply Voltage	
Between V+ and Frame GND	16V
Between V+ and Substrate GND	16V
DC Current (Out of Delayed AGC)	2mA
Power Dissipation	
Up to $T_A = +60^\circ\text{C}$	600mW
Above $T_A = +60^\circ\text{C}$	Derate Linearly 6.7mW/ $^\circ\text{C}$
Junction Temperature	+175 $^\circ\text{C}$
Junction Temperature (Plastic Package)	+150 $^\circ\text{C}$
Lead Temperature (Soldering 10 Sec.)	+300 $^\circ\text{C}$

### Operating Conditions

Operating Temperature Range	$-40^\circ\text{C} \leq T_A \leq +85^\circ\text{C}$
Storage Temperature Range	$-65^\circ\text{C} \leq T_A \leq +150^\circ\text{C}$

**CAUTION:** Stresses above those listed in "Absolute Maximum Ratings" may cause permanent damage to the device. This is a stress only rating and operation of the device at these or any other conditions above those indicated in the operational sections of this specification is not implied.

### Electrical Specifications $T_A = +25^\circ\text{C}$ , $V_+ = 12\text{V}$ (See Figures 3 and 4)

PARAMETERS (Note 2)	TEST CONDITIONS	LIMITS			UNITS	
		MIN	TYP	MAX		
<b>STATIC (DC) CHARACTERISTICS</b>						
Quiescent Circuit Current	No signal input, Non muted	16	23	30	mA	
DC Voltages:						
Terminal 1 (IF Input)		1.2	1.9	2.4	V	
Terminal 2 (AC Return to Input)		1.2	1.9	2.4	V	
Terminal 3 (DC Bias to Input)		1.2	1.9	2.4	V	
Terminal 6 (Audio Output)		5.0	5.6	6.0	V	
Terminal 10 (DC Reference)	5.0	5.6	6.0	V		
<b>DYNAMIC CHARACTERISTICS</b>						
Input Limiting Voltage (-3dB point), $V_1$ (lim)	-	$f_O = 10.7\text{MHz}$ , $f_{\text{MOD}} = 400\text{Hz}$ , Deviation = $\pm 75\text{kHz}$	-	12	25	$\mu\text{V}$
AM Rejection (Term. 6), AMR	$V_{\text{IN}} = 0.1\text{V}$ , AM Mod. = 30%		45	55	-	dB
Recovered AF Voltage (Term. 6) $V_O$ (AF)	$V_{\text{IN}} = 0.1\text{V}$		300	400	500	mV
Total Harmonic Distortion, THD: (Note 1)						
Single Tuned (Term. 6)			-	0.5	1.0	%
Double Tuned (Term. 6)			-	0.1	-	%
Signal plus Noise to Noise Ratio (Term. 6)			60	67	-	dB

**NOTES:**

1. THD characteristics are essentially a function of the phase characteristics of the network connected between terminals 8, 9, and 10.
2. Terminal numbers refer to 16 pin DIP.

Block Diagram

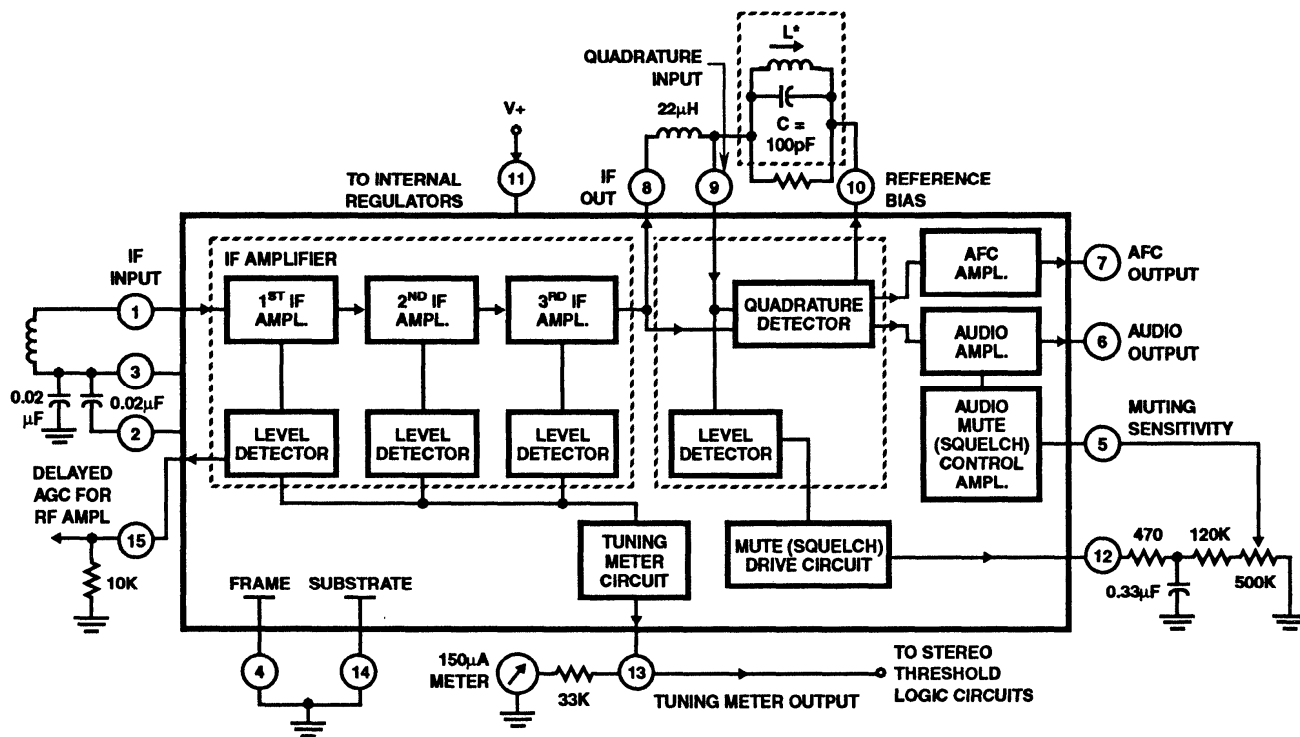

All resistance values are in  $\Omega$   
 \*L Tunes with 100pF (C) at 10.7MHz  
 $Q_0 \approx 75$  (G.I. EX22741 or equivalent)  
 Pin numbers refer to 16 pin DIP

Schematic Diagram

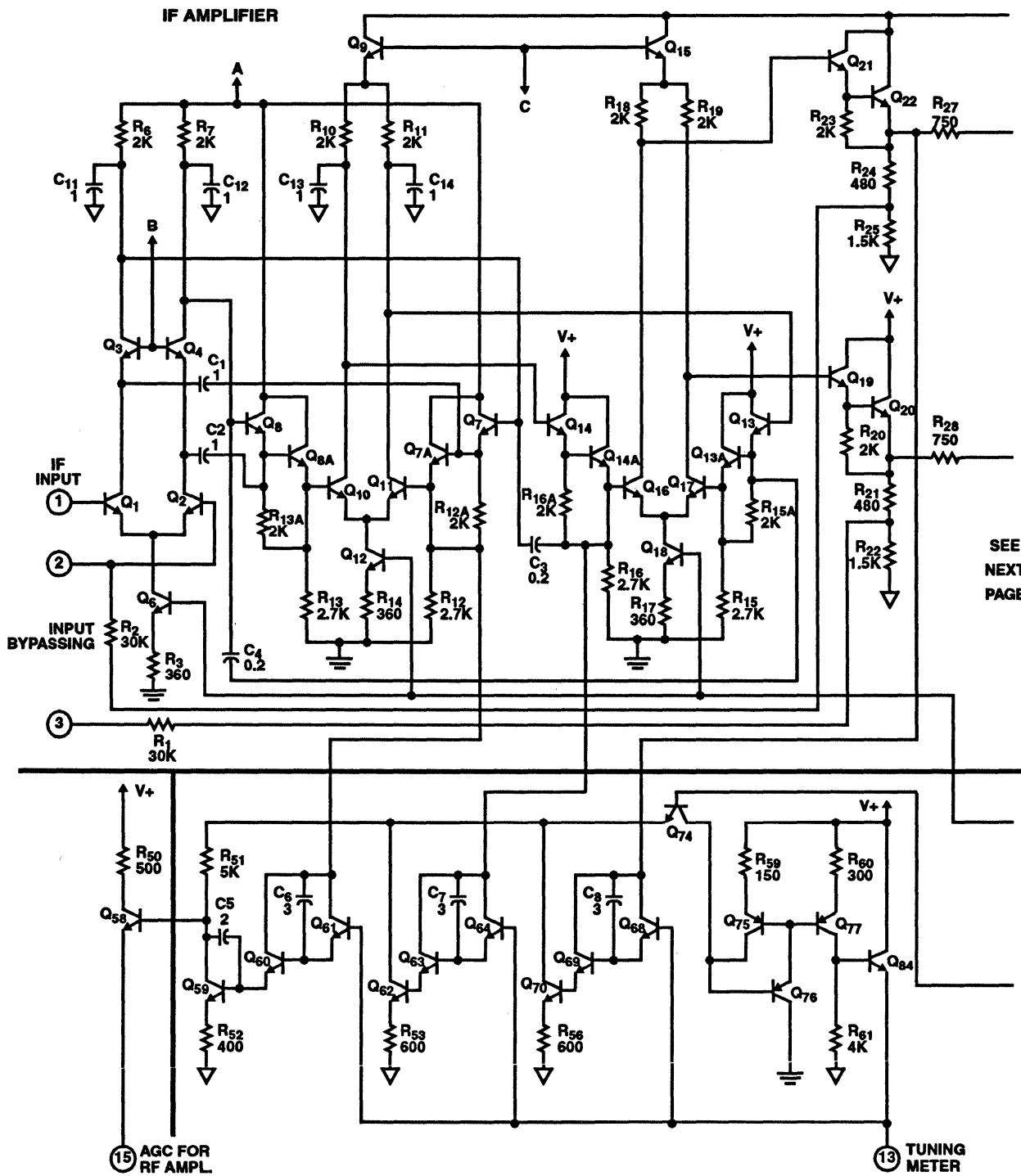

SEE NEXT PAGE

Pin numbers refer to 16 pin DIP

LEVEL DETECTOR & METER CIRCUIT

Schematic Diagram (Continued)

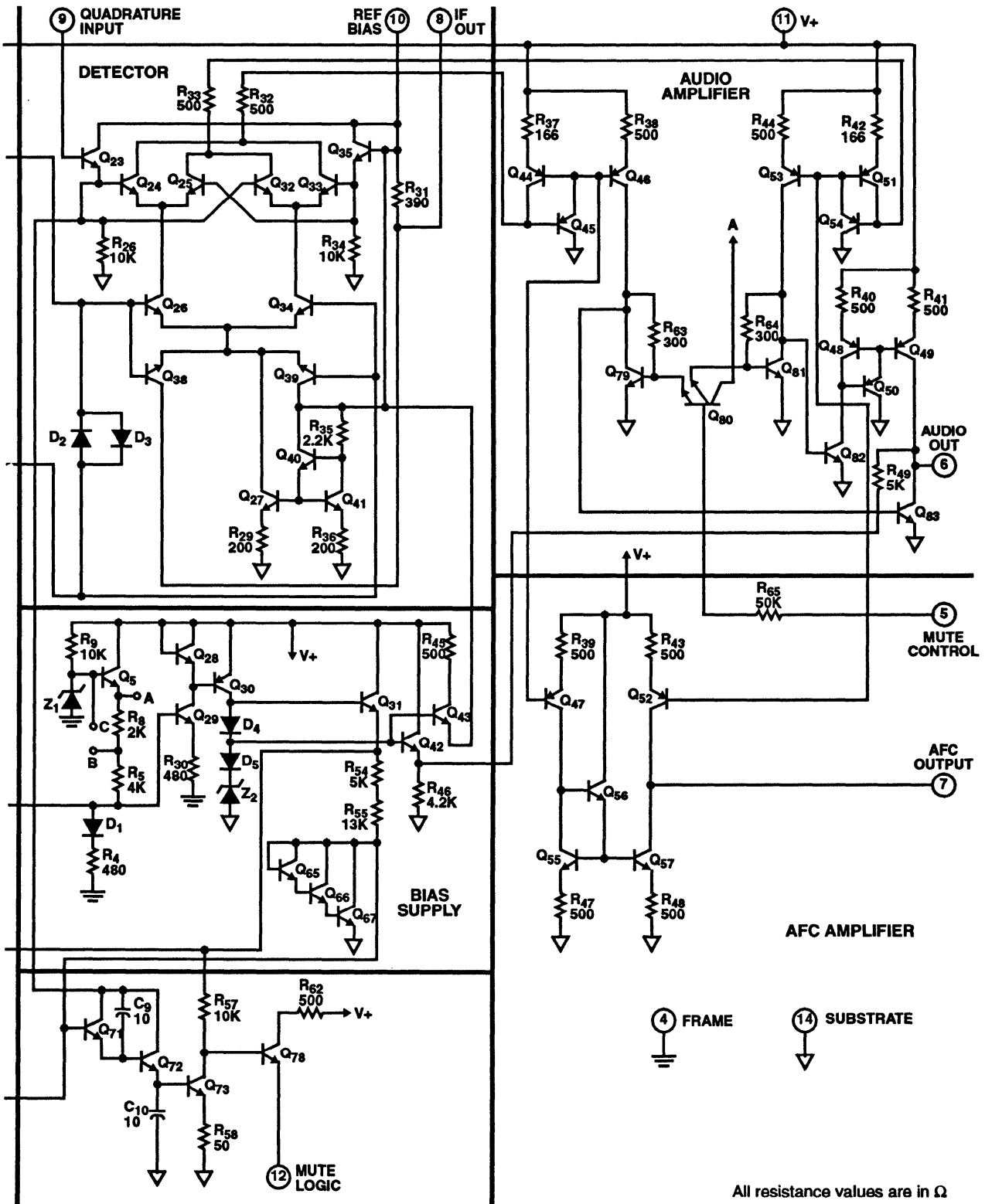

All resistance values are in  $\Omega$   
 All capacitance values are in pF  
 Pin numbers refer to 16 pin DIP

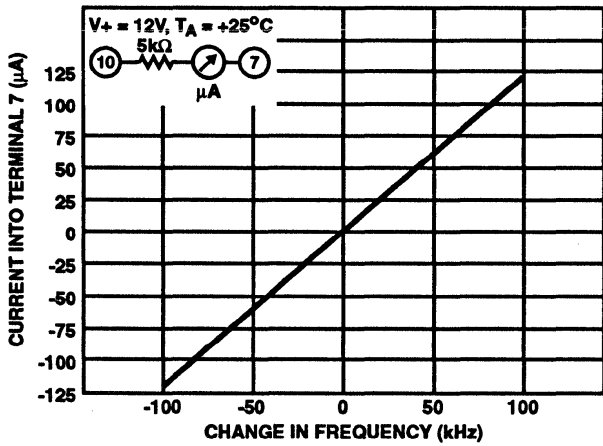

FIGURE 1. AFC CHARACTERISTICS (CURRENT AT TERM. 7) AS A FUNCTION OF CHANGE IN FREQUENCY. (SEE TEST CIRCUIT FIGURE 3.)

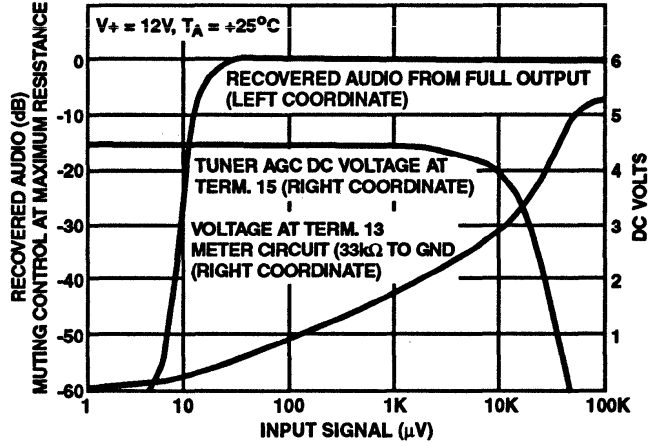
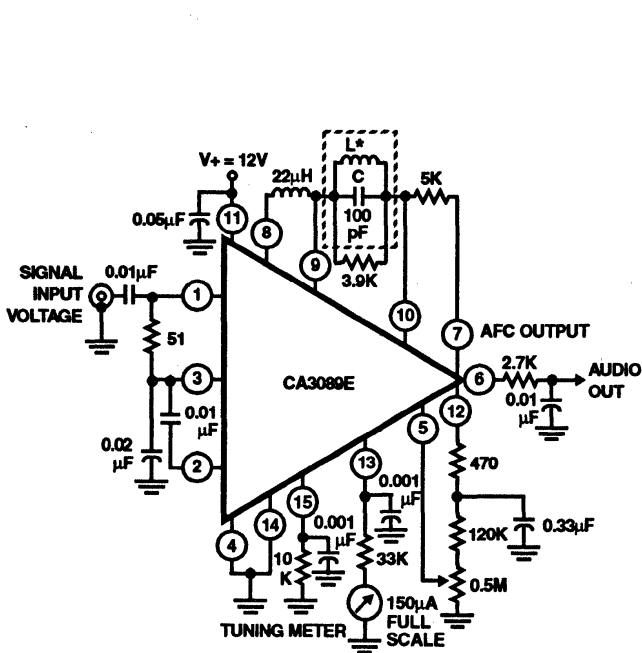
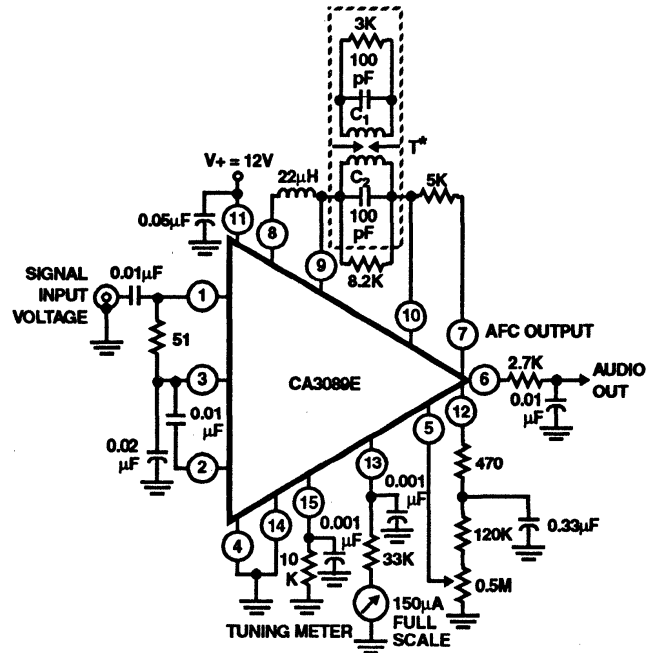

FIGURE 2. MUTING ACTION, TUNER AGC, AND TUNING METER OUTPUT AS A FUNCTION OF INPUT SIGNAL VOLTAGE. (SEE TEST CIRCUIT FIGURE 3.)



All resistance values are in Ω  
 \* L tunes with 100pF (C) at 10.7MHz  
 Q<sub>0</sub> (unloaded) ≅ 75 (G.I. Automatic Mfg. Div. EX22741 or equivalent)

FIGURE 3. TEST CIRCUIT FOR CA3089E USING A SINGLE-TUNED DETECTOR COIL.



All resistance values are in Ω  
 \* T PRI. - Q<sub>0</sub> (unloaded) ≅ 75 (tunes with 100pF (C<sub>1</sub>) 20† of 34e on 7/32" dia. form)  
 SEC. - Q<sub>0</sub> (unloaded) ≅ 75 (tunes with 100pF (C<sub>2</sub>) 20† of 34e on 7/32" dia. form)  
 kQ (percent of critical coupling) ≅ 70%  
 (Adjusted for coil voltage V<sub>C</sub>) = 150mV  
 Above values permit proper operation of mute (squench) circuit "E" type slugs, spacing 4mm.

FIGURE 4. TEST CIRCUIT FOR CA3089E USING A DOUBLE-TUNED DETECTOR COIL.

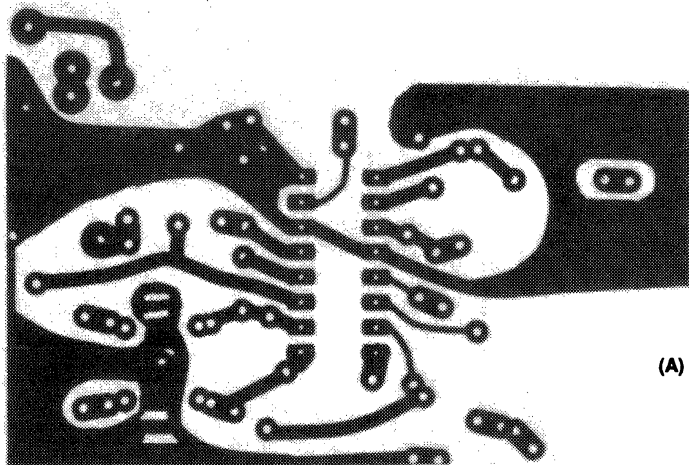

(A) BOTTOM VIEW OF PRINTED CIRCUIT BOARD

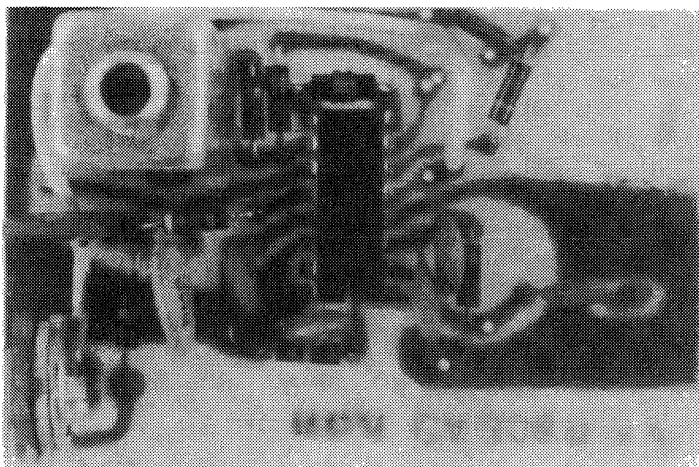

(B) COMPONENT SIDE - TOP VIEW

FIGURE 5. ACTUAL SIZE PHOTOGRAPHS OF THE CA3089E & OUTBOARD COMPONENTS MOUNTED ON A PRINTED-CIRCUIT BOARD.

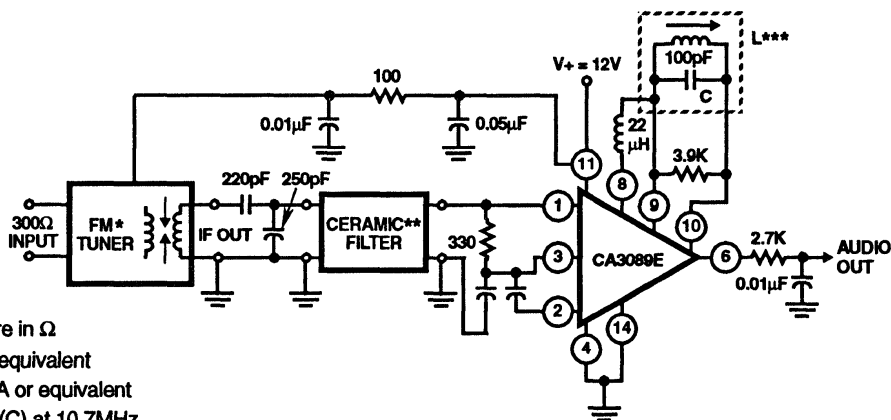

All resistance values are in  $\Omega$

\* Waller 4SN3FIC or equivalent

\*\* Murata SFG 10.7mA or equivalent

\*\*\* L tunes with 100pF (C) at 10.7MHz

$Q_0$  unloaded  $\cong 75$  (G.I. EX22741 or equivalent)

Performance data at  $f_0 = 98\text{MHz}$ ,  $f_{\text{MOD}} = 400\text{Hz}$ , Deviation =  $\pm 75\text{kHz}$ :

-3dB Limiting Sensitivity . . . . .  $2\mu\text{V}$  (Antenna Level)

20dB Quieting Sensitivity . . . . .  $1\mu\text{V}$  (Antenna Level)

30dB Quieting Sensitivity . . . . .  $1.5\mu\text{V}$  (Antenna Level)

FIGURE 6. TYPICAL FM TUNER USING THE CA3089E WITH A SINGLE TUNED DETECTOR COIL