

### FEATURES/BENEFITS

- 11 outputs
- Balanced Drive Outputs  $\pm 12\text{mA}$
- Synchronous output enable (sOE) control for SDRAM power down mode
- External feedback, internal loop filter
- Low skew guaranteed between outputs
- Supports 33MHz to 100MHz SDRAMs
- JEDEC Compatible LVTTTL
- 3.0V to 3.6V supply voltage
- Industrial temperature range
- Inputs are 5V tolerant
- Available in 24-pin QSOP, TSSOP package

### DESCRIPTION

The QS5920 is a high-performance, low skew, low jitter, multiple output phase locked loop clock driver. It provides precise phase and frequency alignment of its clock outputs to an externally applied clock input signal. The QS5920 has been specially designed to interface with high speed SDRAM applications in the range of 33MHz to 100MHz and includes an internal RC filter which provides excellent jitter characteristics and eliminates the need for external components. The synchronous output enable (sOE) control sets all outputs except QFB (which may be used to maintain phase lock) LOW on a subsequent negative clock transition: partial output clock pulses are not produced.

**Figure 1. Logic Block Diagram and Pinout**

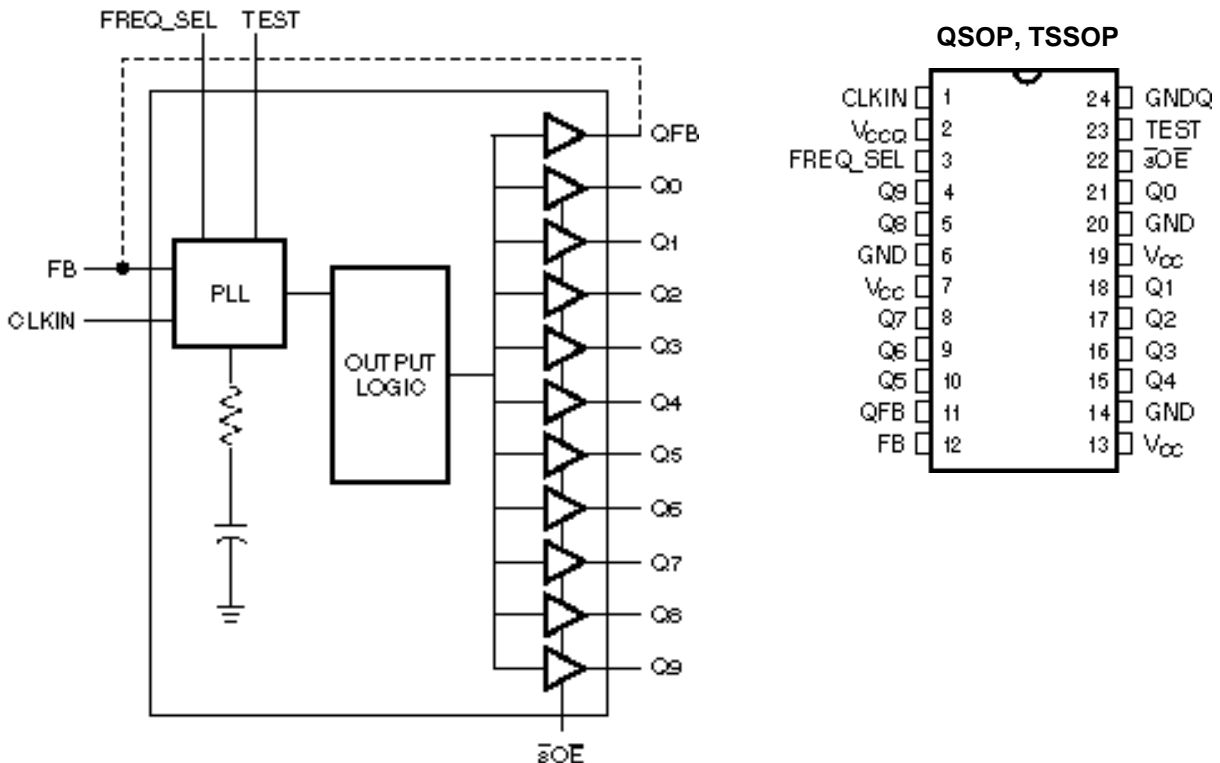

**Table 1. Pin Description**

Pin Name	I/O	Functional Description
CLKIN	I	Clock input
Q0..Q9	O	Clock outputs
FB	I	PLL feedback input normally connected to QFB by user. May be connected to any output if sOE is strapped low.
QFB	O	Dedicated clock output for the FB pin (non-disable)
sOE	I	Synchronous output enable. Asserted LOW for normal operation. When asserted HIGH, clock outputs (except QFB) are forced LOW.
TEST	I	When LOW, PLL is in normal operation. When HIGH, it disables PLL and opens DC bypass. CLKIN goes to all outputs.
FREQ_SEL <sup>(1)</sup>	I	VCO frequency select. For optimising the VCO operating frequency. Set LOW for input frequencies within 33MHz to 75MHz, and HIGH for 66MHz to 100MHz.
V <sub>CC</sub>	—	Power supply for output buffers
V <sub>CCQ</sub>	—	Power supply (quiet) for PLL
GND	—	Ground supply for output buffers
GNDQ	—	Ground supply (quiet) for PLL

**Note:**

1. If this input is switched, the function and timing of the outputs may glitch, and the PLL may require an additional  $t_{LOCK}$  time before all datasheet limits are achieved.

**Table 2. Absolute Maximum Ratings**

Supply Voltage to Ground .....	-0.5V to +7.0V
DC Output Voltage V <sub>OUT</sub> .....	-0.5V to V <sub>CC</sub> +0.5V
DC Input Voltage V <sub>IN</sub> .....	-0.5V to +7.0V
DC Input Diode Current with V <sub>I</sub> < 0 .....	-20mA
Maximum Power Dissipation At T <sub>A</sub> = 85°C, .....	0.55W
T <sub>STG</sub> Storage Temperature .....	-65° to +150°C

**Note:** Stresses greater than those listed under absolute maximum ratings may cause permanent damage to QSI devices that result in functional or reliability type failures.

**Table 3. Capacitance**

T<sub>A</sub> = 25°C, f = 1MHz, V<sub>IN</sub> = 0V

	QSOP		TSSOP		Units
	Typ	Max	Typ	Max	
C <sub>IN</sub>	5	7	5	7	pF

**Note:** Capacitance is characterized but not tested.

**Table 4. Recommended Operating Conditions**

Symbol	Parameter	Min	Max	Unit
V <sub>CC</sub>	Power Supply Voltage	3.0	3.6	V
V <sub>IN</sub>	Input Voltage	0	V <sub>CC</sub>	V
T <sub>A</sub>	Ambient Operating Temperature	-40	85	°C

**Table 5. DC Electrical Characteristics Over Operating Range**

Symbol	Parameter	Test Condition	Min	Typ <sup>(1)</sup>	Max	Unit
V <sub>IH</sub>	Input HIGH Voltage	Guaranteed Logic HIGH for inputs	2.0			V
V <sub>IL</sub>	Input LOW Voltage	Guaranteed Logic LOW for inputs			0.8	V
V <sub>IC</sub>	Clamp Diode Voltage	V <sub>CC</sub> = Min., I <sub>IN</sub> = -18mA		-0.7	-1.2	V
V <sub>OH</sub>	Output HIGH Voltage (Q0:9, QFB)	V <sub>CC</sub> = Min., I <sub>OH</sub> = -12mA V <sub>CC</sub> = Min., I <sub>OH</sub> = -8mA V <sub>CC</sub> = Min., I <sub>OH</sub> = -100µA	2.0 2.4 2.8			V
V <sub>OL</sub>	Output LOW Voltage (Q0:9, QFB)	V <sub>CC</sub> = Min., I <sub>OL</sub> = 12mA V <sub>CC</sub> = Min., I <sub>OL</sub> = 8mA V <sub>CC</sub> = Min., I <sub>OL</sub> = 100µA			0.5 0.4 0.2	V
I <sub>IN</sub>	Input Leakage Current	V <sub>CC</sub> = Max., 0 V <sub>IN</sub> V <sub>CC</sub>			1	µA

**Note:**

1. Typical values indicate V<sub>CC</sub> = 3.3V and T<sub>A</sub> = 25°C.

**Table 6. Power Supply Characteristics**

Symbol	Parameter	Test Conditions	Typ	Max	Unit
I <sub>CCQ</sub>	Quiescent Power Supply Current	V <sub>CC</sub> = Max., TEST = High, CLKIN = Low sOE = Low, All outputs unloaded	15	30	mA
I <sub>CC</sub>	Power Supply Current Per Input HIGH <sup>(1)</sup>	V <sub>CC</sub> = Max., V <sub>IN</sub> = 3.0V	1.0	30	µA
I <sub>CCD</sub>	Dynamic Power Supply Current Per Output <sup>(1)</sup>	V <sub>CC</sub> = Max., C <sub>L</sub> = 0pF	55	90	µA/ MHz
I <sub>C</sub>	Total Power Supply Current <sup>(1)</sup>	V <sub>CC</sub> = 3.3V, f <sub>CLKIN</sub> = 50MHz, C <sub>L</sub> = 165pF <sup>(2)</sup>	70		mA
I <sub>C</sub>	Total Power Supply Current <sup>(1)</sup>	V <sub>CC</sub> = 3.3V, f <sub>CLKIN</sub> = 100MHz, C <sub>L</sub> = 165pF <sup>(2)</sup>	130		mA

**Notes:**

1. Guaranteed by characterization but not production tested.
2. For 11 outputs each loaded with 15pF.

**Table 7. Switching Characteristics Over Operating Range**

$C_{LOAD} = 15\text{pF}$

Symbol	Description	Min	Max	Unit
$t_{PWC}$	Input clock pulse, high or low <sup>(1)</sup>	2.5	—	ns
$f_{CLKIN}$	Input frequency	33	100	MHz
$t_{PD}$	CLKIN input to FB delay <sup>(1)</sup>	-350	+350	ps
$t_{SK1}$	Output - Output skew, all outputs, same transition <sup>(1)</sup>	—	250	ps
$t_J$	Cycle to cycle jitter, 65MHz <sup>(1)</sup>	-100	+100	ps
$t_{PW}$	Output duty cycle distortion <sup>(1,2)</sup>	45	55	%
$t_{OPW}$	Output pulse width distortion <sup>(1,2)</sup>	$T_{CYCLE}/2 - 0.65$	$T_{CYCLE}/2 + 0.65$	ns
$t_{LOCK}$	CLKIN to phase lock	0.1	0.5	ms
$t_R, t_F$	Output rise and fall times (0.8V to 2.0V) <sup>(1)</sup>	—	1.2	ns
$t_{DEV}$	Skew between two outputs of different devices <sup>(1,3)</sup>	—	1.0	ns

$C_{LOAD} = 30\text{pF}$

Symbol	Description	Min	Max	Unit
$t_{PWC}$	Input clock pulse, high or low <sup>(1)</sup>	2.5	—	ns
$f_{CLKIN}$	Input frequency	33	100	MHz
$t_{PD}$	CLKIN input to FB delay <sup>(1)</sup>	-350	+350	ps
$t_{SK1}$	Output - Output skew, all outputs, same transition <sup>(1)</sup>	—	350	ps
$t_J$	Cycle to cycle jitter, 65MHz <sup>(1)</sup>	-100	+100	ps
$t_{PW}$	Output duty cycle distortion <sup>(1,2)</sup>	45	55	%
$t_{OPW}$	Output pulse width distortion <sup>(1,2)</sup>	$T_{CYCLE}/2 - 0.65$	$T_{CYCLE}/2 + 0.65$	ns
$t_{LOCK}$	CLKIN to phase lock	0.1	0.5	ms
$t_R, t_F$	Output rise and fall times (0.8V to 2.0V) <sup>(1)</sup>	—	1.6	ns
$t_{DEV}$	Skew between two outputs of different devices <sup>(1,3)</sup>	—	1.25	ns

**Notes:**

1. This parameter is guaranteed by design and verified during production by statistical correlation.
2. Output signal is nominally 50% duty cycle: maximum error is  $\pm 5\%$  of the period or 0.65ns, whichever is the greater.
3.  $t_{DEV}$  applies to any device operating under the same conditions ( $V_{CC}$ , ambient temperature, package, air flow, etc.)

Figure 2. AC Test Loads and Waveforms

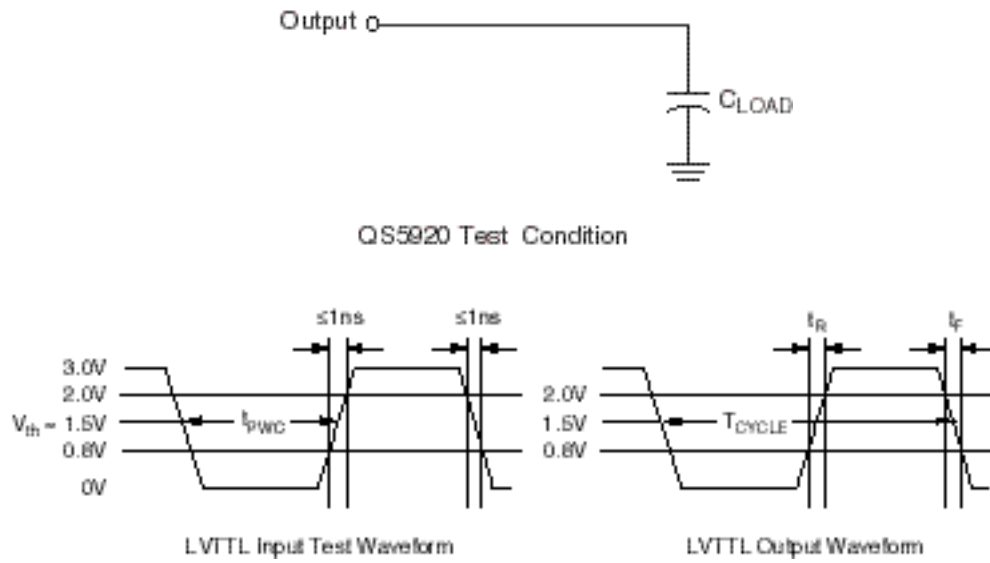

Figure 3. AC Timing Diagram

