

National Semiconductor is now part of  
Texas Instruments.

Search <http://www.ti.com/> for the latest technical  
information and details on our current products and services.

# SM72442

## Programmable Maximum Power Point Tracking Controller for Photovoltaic Solar Panels

### General Description

The SM72442 is a programmable MPPT controller capable of controlling four PWM gate drive signals for a 4-switch buck-boost converter. The SM72442 also features a proprietary algorithm called Panel Mode which allows for the panel to be connected directly to the output of your power optimizer circuit. Along with the SM72295 (Photovoltaic Full Bridge Driver), it creates a solution for an MPPT configured DC-DC converter with efficiencies up to 99.5%. Integrated into the chip is an 8-channel, 12 bit A/D converter used to sense input and output voltages and currents, as well as board configuration. Externally programmable values include maximum output voltage and current as well as different settings for slew rate, soft-start and Panel Mode.

### Features

- Renewable Energy Grade
- Programmable maximum power point tracking
- Photovoltaic solar panel voltage and current diagnostic
- Single inductor four switch buck-boost converter control
- I2C interface for communication
- VOUT Overvoltage protection
- Over-current protection

### Package

- TSSOP-28



### Block Diagram

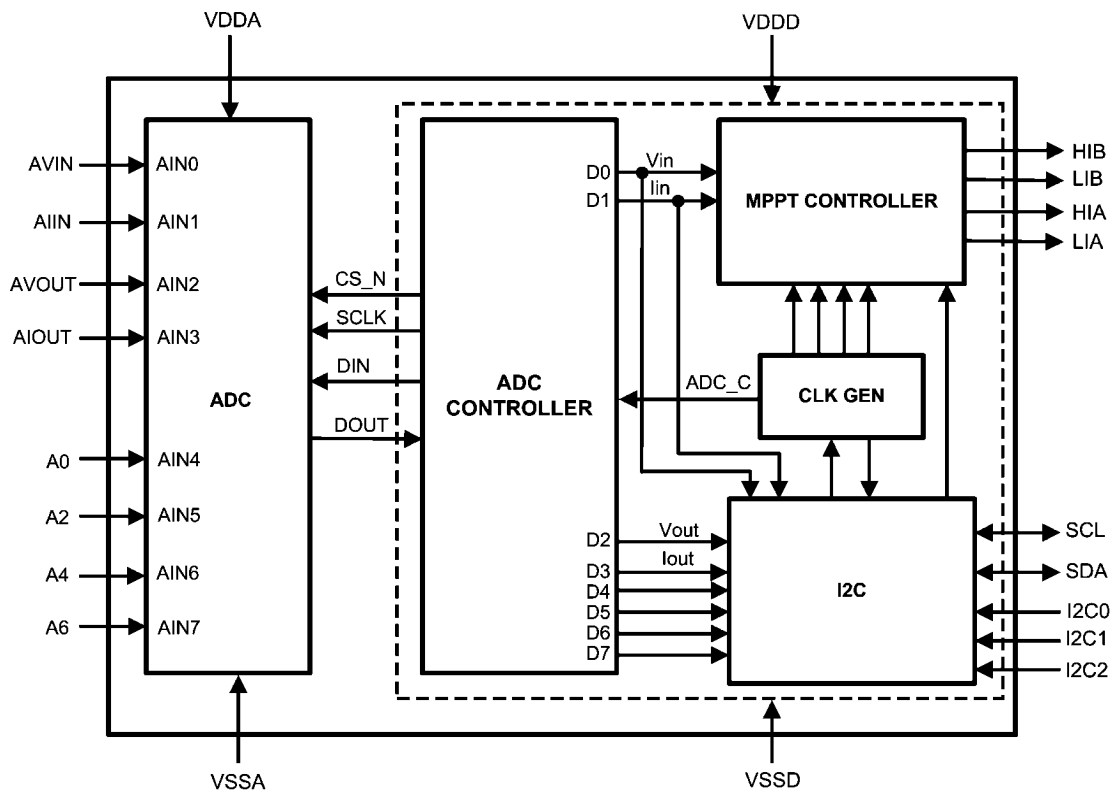

30134302

FIGURE 1. Block Diagram

SM72442 Programmable Maximum Power Point Tracking Controller for Photovoltaic Solar Panels

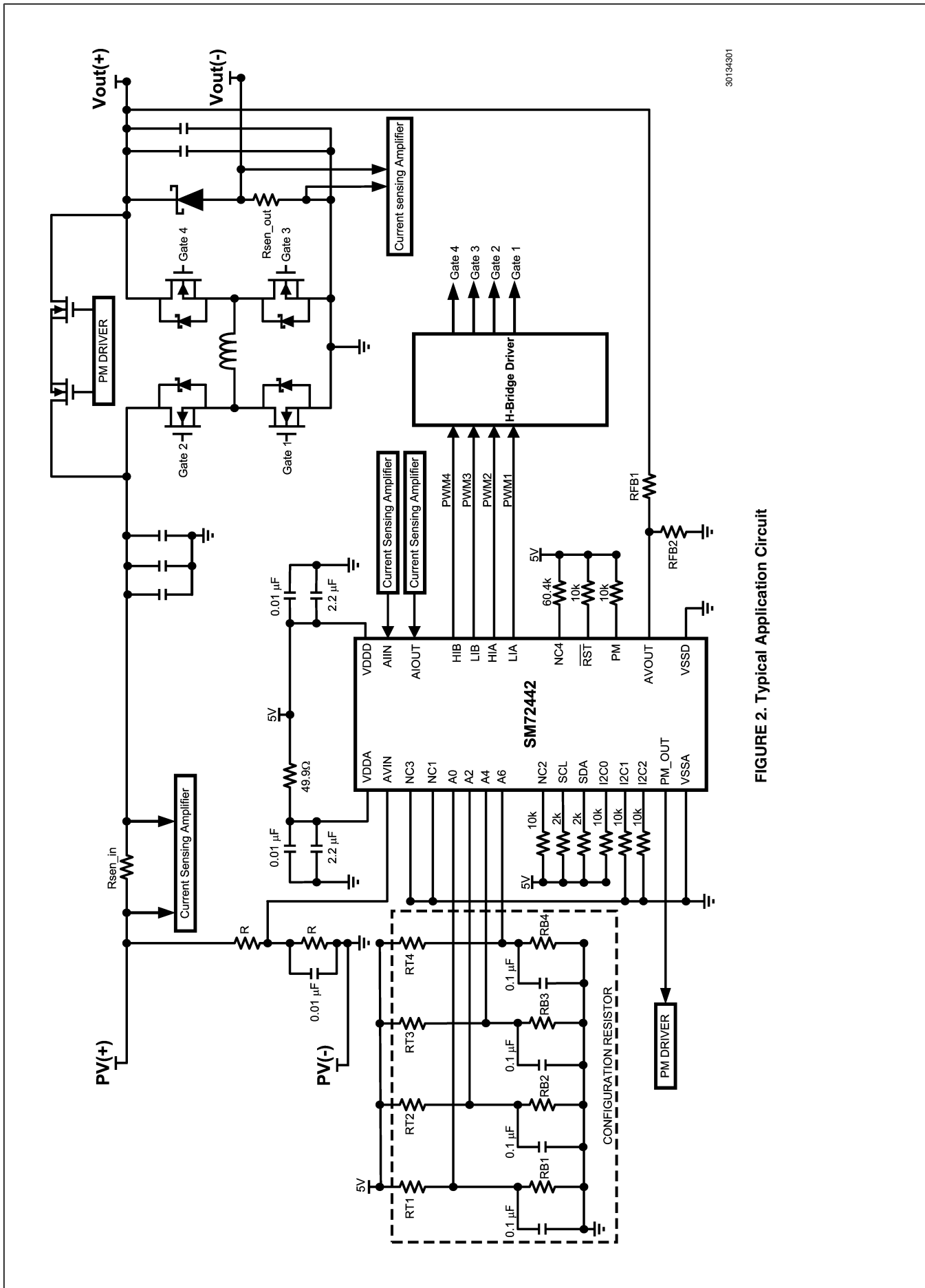

30134301

FIGURE 2. Typical Application Circuit

## Connection Diagram

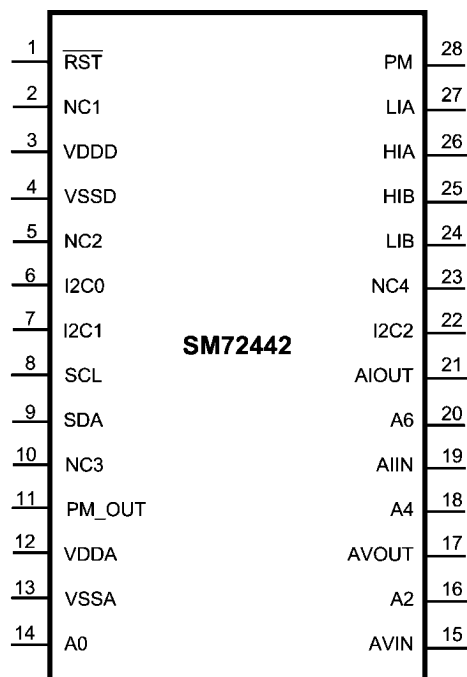

30134303

**FIGURE 3. Top View  
TSSOP-28**

## Ordering Information

Order Number	Description	NSC Package Drawing	Supplied As	Package Top Marking
SM72442MTX	TSSOP-28	MTC28	2500 Units in Tape and Reel	SO2442
SM72442MTE	TSSOP-28	MTC28	250 Units in Tape and Reel	SO2442
SM72442MT	TSSOP-28	MTC28	48 Units in Rail	SO2442

## Pin Descriptions

Pin	Name	Description
1	$\overline{\text{RST}}$	Active low signal. External reset input signal to the digital circuit.
2	NC1	Reserved for test only. This pin should be grounded.
3	VDDD	Digital supply voltage. This pin should be connected to a 5V supply, and bypassed to VSSD with a 0.1 $\mu\text{F}$ monolithic ceramic capacitor.
4	VSSD	Digital ground. The ground return for the digital supply and signals.
5	NC2	No Connect. This pin should be pulled up to the 5V supply using 10k resistor.
6	I2C0	Addressing for I2C communication.
7	I2C1	Addressing for I2C communication.
8	SCL	I2C clock.
9	SDA	I2C data.
10	NC3	Reserved for test only. This pin should be grounded.
11	PM_OUT	When Panel Mode is active, this pin will output a 400 kHz square wave signal with amplitude of 5V. Otherwise, it stays low.
12	VDDA	Analog supply voltage. This voltage is also used as the reference voltage. This pin should be connected to a 5V supply, and bypassed to VSSA with a 1 $\mu\text{F}$ and 0.1 $\mu\text{F}$ monolithic ceramic capacitor.
13	VSSA	Analog ground. The ground return for the analog supply and signals.
14	A0	A/D Input Channel 0. Connect a resistor divider to 5V supply to set the maximum output voltage. Please refer to the application section for more information on setting the resistor value.
15	AVIN	Input voltage sensing pin.
16	A2	A/D Input Channel 2. Connect a resistor divider to a 5V supply to set the condition to enter and exit Panel Mode (PM). Refer to configurable modes for SM72442 in the application section.
17	AVOUT	Output voltage sensing pin.
18	A4	A/D Input Channel 4. Connect a resistor divider to a 5V supply to set the maximum output current. Please refer to the application section for more information on setting the resistor value.
19	AIIN	Input current sensing pin.
20	A6	A/D Input Channel 6. Connect a resistor divider to a 5V supply to set the output voltage slew rate and various PM configurations. Refer to configurable modes for SM72442 in the application section.
21	AIOUT	Output current sensing pin.
22	I2C2	Addressing for I2C communication.
23	NC4	No Connect. This pin should be connected with 60.4k pull-up resistor to 5V.
24	LIB	Low side boost PWM output.
25	HIB	High side boost PWM output.
26	HIA	High side buck PWM output.
27	LIA	Low side buck PWM output.
28	PM	Panel Mode Pin. Active low. Pulling this pin low will force the chip into Panel Mode.

## Absolute Maximum Ratings *(Note 1)*

If Military/Aerospace specified devices are required, please contact the National Semiconductor Sales Office/Distributors for availability and specifications.

Analog Supply Voltage $V_A$ (VDDA - VSSA)	-0.3 to 6.0V
Digital Supply Voltage $V_D$ (VDDD - VSSD)	-0.3 to $V_A + 0.3V$ max 6.0V
Voltage on Any Pin to GND	-0.3 to $V_A + 0.3V$
Input Current at Any Pin (Note 3)	$\pm 10$ mA
Package Input Current (Note 3)	$\pm 20$ mA
Storage Temperature Range	-65°C to +150°C
ESD Rating	<i>(Note 2)</i>
Human Body Model	2 kV

## Recommended Operating Conditions

Operating Temperature	-40°C to 105°C
$V_A$ Supply Voltage	+4.75V to +5.25V
$V_D$ Supply Voltage	+4.75V to $V_A$
Digital Input Voltage	0 to $V_A$
Analog Input Voltage	0 to $V_A$
Junction Temperature	-40°C to 125°C

Specifications in standard typeface are for  $T_J = 25^\circ\text{C}$ , and those in boldface type apply over the full operating junction temperature range. *(Note 3)*

Symbol	Parameter	Conditions	Min	Typ	Max	Units
<b>ANALOG INPUT CHARACTERISTICS</b>						
AVin, Alin AVout, Alout	Input Range		-	0 to $V_A$	-	V
$I_{DCL}$	DC Leakage Current		-	-	<b><math>\pm 1</math></b>	$\mu\text{A}$
$C_{INA}$	Input Capacitance <i>(Note 4)</i>	Track Mode	-	33	-	pF
		Hold Mode	-	3	-	pF
<b>DIGITAL INPUT CHARACTERISTICS</b>						
$V_{IL}$	Input Low Voltage		-	-	<b>0.8</b>	V
$V_{IH}$	Input High Voltage		<b>2.8</b>	-	-	V
$C_{IND}$	Digital Input Capacitance <i>(Note 4)</i>		-	2	<b>4</b>	pF
$I_{IN}$	Input Current		-	$\pm 0.01$	<b><math>\pm 1</math></b>	$\mu\text{A}$
<b>DIGITAL OUTPUT CHARACTERISTICS</b>						
$V_{OH}$	Output High Voltage	$I_{SOURCE} = 200 \mu\text{A}$ $V_A = V_D = 5V$	<b><math>V_D - 0.5</math></b>	-	-	V
$V_{OL}$	Output Low Voltage	$I_{SINK} = 200 \mu\text{A}$ to 1.0 mA $V_A = V_D = 5V$	-	-	<b>0.4</b>	V
$I_{OZH}, I_{OZL}$	Hi-Impedance Output Leakage Current	$V_A = V_D = 5V$			<b><math>\pm 1</math></b>	$\mu\text{A}$
$C_{OUT}$	Hi-Impedance Output Capacitance <i>(Note 4)</i>			2	<b>4</b>	pF
<b>POWER SUPPLY CHARACTERISTICS (<math>C_L = 10</math> pF)</b>						
$V_A, V_D$	Analog and Digital Supply Voltages	$V_A \geq V_D$	<b>4.75</b>	5	<b>5.25</b>	V
$I_A + I_D$	Total Supply Current	$V_A = V_D = 4.75V$ to 5.25V	-	11.5	<b>15</b>	mA
$P_C$	Power Consumption	$V_A = V_D = 4.75V$ to 5.25V		57.5	<b>78.75</b>	mW
<b>PWM OUTPUT CHARACTERISTICS</b>						
$f_{PWM}$	PWM switching frequency			220		kHz

**Note 1:** Absolute Maximum Ratings indicate limits beyond which damage to the component may occur. Operating Ratings are conditions under which operation of the device is guaranteed. Operating Ratings do not imply guaranteed performance limits. For guaranteed performance limits and associated test conditions, see the Electrical Characteristics tables.

**Note 2:** The human body model is a 100 pF capacitor discharged through a 1.5 k $\Omega$  resistor into each pin.

**Note 3:** Min and Max limits are 100% production tested at 25°C. Limits over the operating temperature range are guaranteed through correlation using Statistical Quality Control (SQC) methods. Limits are used to calculate National's Average Outgoing Quality Level (AOQL).

**Note 4:** Not tested. Guaranteed by design.

## Operation Description

### OVERVIEW

The SM72442 is a programmable MPPT controller capable of outputting four PWM gate drive signals for a 4-switch buck-boost converter with an independent Panel Mode. The typical application circuit is shown in [Figure 2](#).

The SM72442 uses an advanced digital controller to generate its PWM signals. A maximum power point tracking (MPPT) algorithm monitors the input current and voltage and controls the PWM duty cycle to maximize energy harvested from the

photovoltaic module. MPPT performance is very fast. Convergence to the maximum power point of the module typically occurs within 0.01s. This enables the controller to maintain optimum performance under fast-changing irradiance conditions.

Transitions between buck, boost, and Panel Mode are smoothed and advanced digital PWM dithering techniques are employed to increase effective PWM resolution. Output voltage and current limiting functionality are integrated into the digital control logic. The controller is capable of handling both shorted and no-load conditions and will recover smoothly from both conditions.

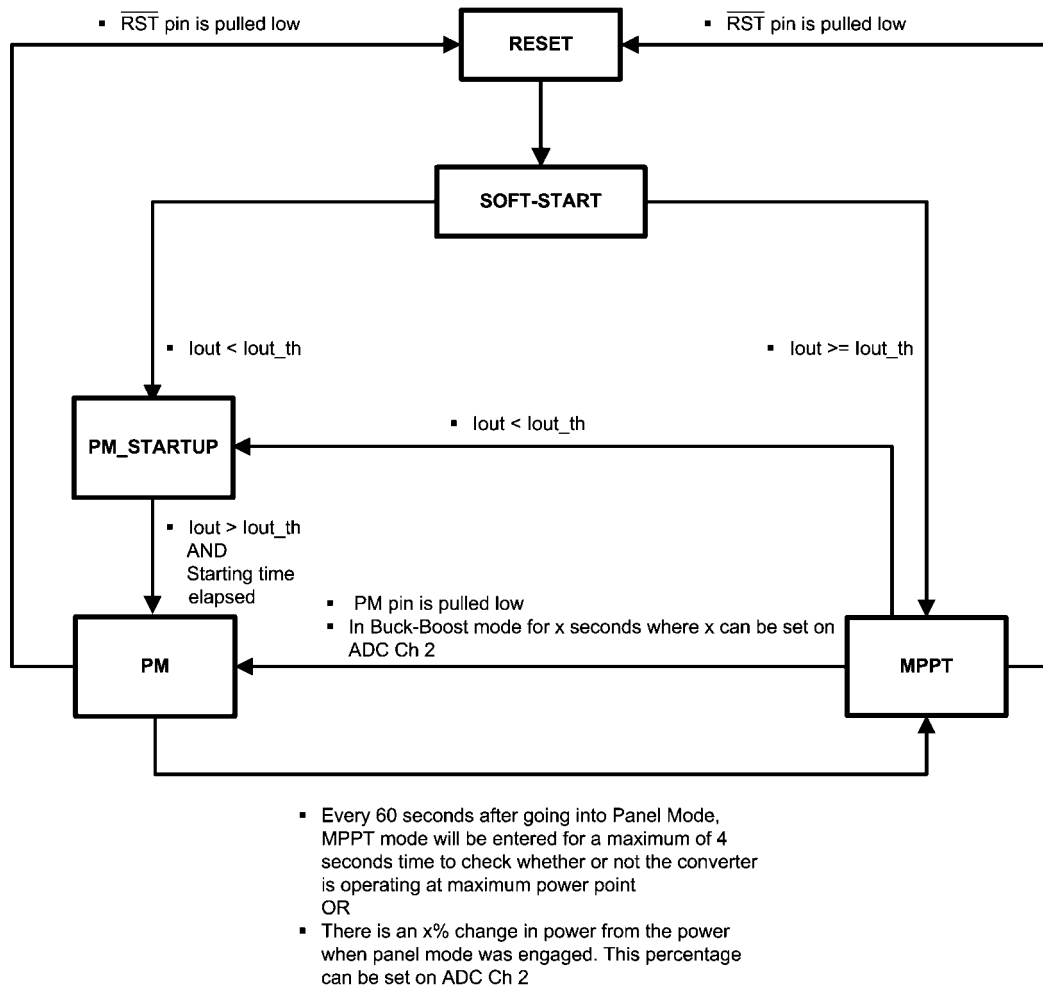

30134304

FIGURE 4. High Level State Diagram for Startup

## STARTUP

SM72442 has a soft start feature that will ramp its output voltage for a fixed time of 250ms.

If no output current is detected during soft-start time, the chip will then be in Panel Mode for 60 seconds. A counter will start once the minimum output current threshold is met (set by ADC input channel 4). During these 60 seconds, any variation on the output power will not cause the chip to enter MPPT mode. Once 60 seconds have elapsed, at a certain power level variation at the output (set by ADC input channel 2) will engage the chip in MPPT mode.

If the output current exceeded the current threshold set at A/D Channel 6 (A6) during soft-start, the chip will then engage in MPPT mode.

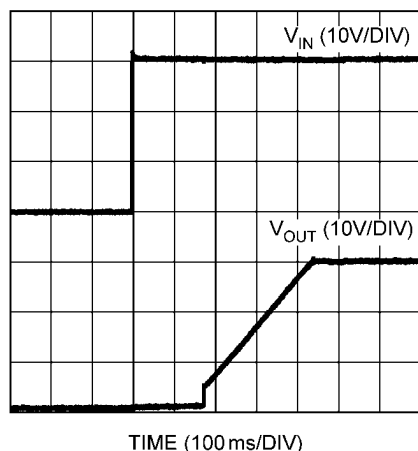

30134305

FIGURE 5. Startup Sequence

## MAXIMUM OUTPUT VOLTAGE

Maximum output voltage on the SM72442 is set by resistor divider ratio on pin A0. (Please refer to [Figure 2](#) Typical Application Circuit).

$$V_{OUT\_MAX} = 5 \times \frac{RB1}{RT1 + RB1} \times \frac{(RFB1 + RFB2)}{RFB1}$$

Where RT1 and RB1 are the resistor divider on the ADC pin A0 and RFB1 and RFB2 are the output voltage sense resistors. A typical value for RFB2 is about 2 kΩ

A6	Output Voltage Slew Rate Limit	Starting Panel Mode Time	MPPT Exit Threshold	MPPT Start Threshold	Starting boost ratio
4.69 V	Slow	Not applicable	0 mA	0 mA	1:1
4.06 V	Slow	60s	75mA	125mA	1:1
3.44 V	Slow	0s	300mA	500mA	1:1
2.81 V	Slow	120s	300mA	500mA	1:1
2.19 V	Slow	Not applicable	300mA	500mA	1:1.2
1.56 V	Slow	60s	300mA	500mA	1:1
0.94 V	Fast	60s	300mA	500mA	1:1
0.31 V	No slew rate limit	60s	300mA	500mA	1:1

## CURRENT LIMIT SETTING

Maximum output current can be set by changing the resistor divider on A4 (pin 18). Refer to [Figure 2](#). Overcurrent at the output is detected when the voltage on AIOOUT (pin 21) equals the voltage on A4 (pin 18). The voltage on A4 can be set by a resistor divider connected to 5V whereas the voltage on AIOOUT can be set by a current sense amplifier.

## AVIN PIN

AVIN is an A/D input to sense the input voltage of the SM72442. A resistor divider can be used to scale max voltage to about 4V, which is 80% of the full scale of the A/D input.

## CONFIGURABLE SETTINGS

A/D pins A0, A2, A4, and A6 are used to configure the behavior of the SM72442 by adjusting the voltage applied to them. One way to do this is through resistor dividers as shown in [Figure 2](#), where RT1 to RT4 should be in the range of 20 kΩ.

Different conditions to enter and exit Panel Mode can be set on the ADC input channel 2. Listed below are different conditions that a user can select on pin A2. “1:1” refers to the state in which the DC/DC converter operates with its output voltage equal to its input voltage (also referred to as “Buck-Boost” mode on [Figure 4](#).)

A2	Entering Panel Mode	Exiting Panel Mode
4.69 V	2s in 1:1 Mode	3.1% power variation
4.06 V	1s in 1:1 Mode	3.1% power variation
3.44 V	0.4s in 1:1 Mode	3.1% power variation
2.81 V	0.2s in 1:1 Mode	3.1% power variation
2.19 V	2s in 1:1 Mode	1.6% power variation
1.56 V	1s in 1:1 Mode	1.6% power variation
0.94 V	0.4s in 1:1 Mode	1.6% power variation
0.31 V	0.2s in 1:1 Mode	1.6% power variation

The user can also select the output voltage slew rate, minimum current threshold and duration of Panel Mode after the soft-start period has finished, by changing the voltage level on pin A6 which is the input of ADC channel 6.



### PARAMETER DEFINITIONS

**Output Voltage Slew Rate Limit Settling Time:** Time constant of the internal filter used to limit output voltage change. For fast slew rate, every 1V increase, the output voltage will be held for 30 ms whereas in a slow slew rate, the output voltage will be held for 62 ms for every 1V increase. (See [Figure 6](#)).

**Starting PM Time:** After initial power-up or reset, the output soft-starts and then enters Panel Mode for this amount of time.

**MPPT Exit Threshold and MPPT Start Threshold:** These are the hysteretic thresholds for  $lout\_th$ .

**Starting Boost Ratio** – This is the end-point of the soft-start voltage ramp. 1:1 ratio means it stops when  $V_{out} = V_{in}$ , 1:1.2 means it stops when  $V_{out} = 1.2 \times V_{in}$ .

### PANEL MODE PIN (PM) PIN

The SM72442 can be forced into Panel Mode by pulling the PM pin low. One sample application is to connect this pin to the output of an external temperature sensor; therefore whenever an over-temperature condition is detected the chip will enter a Panel Mode.

Once Panel Mode is enabled either when buck-boost mode is entered for a certain period of time (adjustable on channel 2 of ADC) or when PM is pulled low, the PM\_OUT pin will output a 400 kHz square wave signal. Using a gate driver and transformer, this square wave signal can then be used to drive a Panel Mode FET as shown in [Figure 7](#).

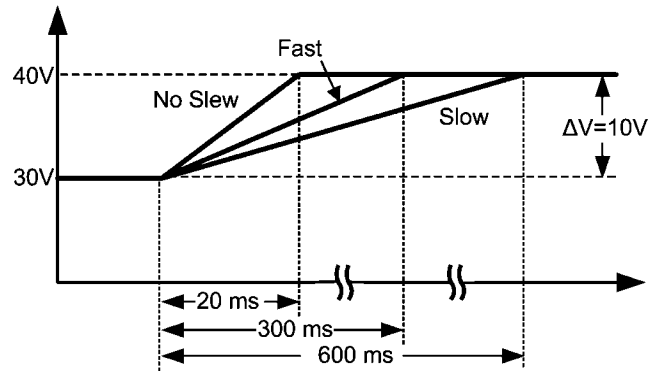

30134313

FIGURE 6. Slew Rate Limitation Circuit

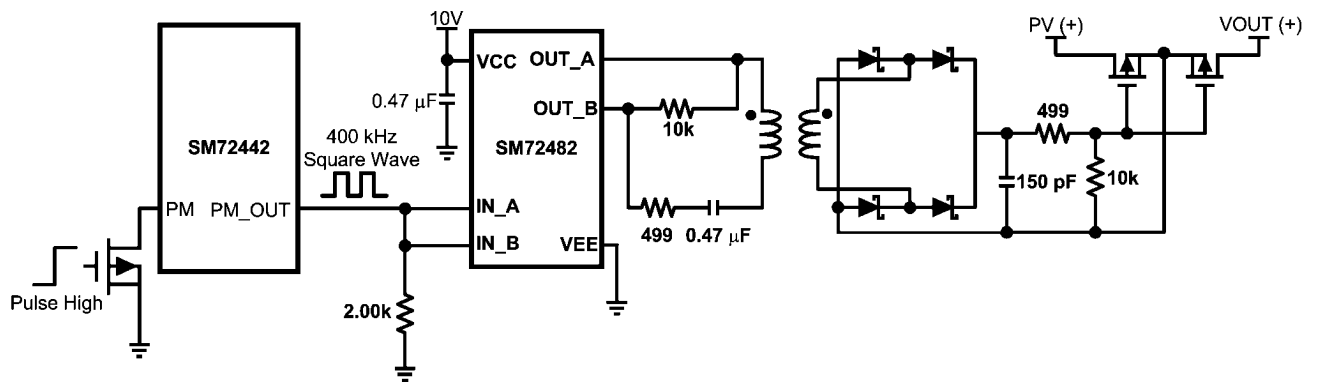

30134307

FIGURE 7. Sample Application for Panel Mode Operation

## RESET PIN

When the reset pin is pulled low, the chip will cease its normal operation and turn-off all of its PWM outputs including the output of PM\_OUT pin. Below is an oscilloscope capture of a forced reset condition.

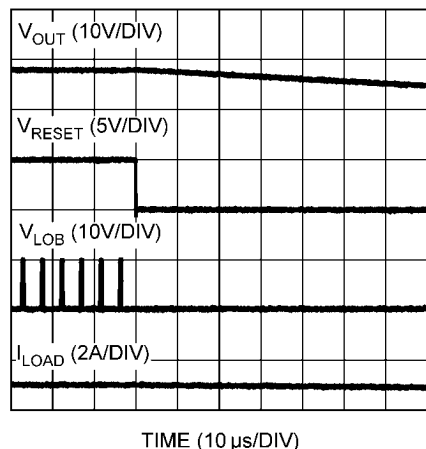

FIGURE 8. Forced Reset Condition

As seen in [Figure 8](#), the initial value for output voltage and load current are 28V and 1A respectively. After the reset pin is grounded both the output voltage and load current decreases immediately. MOSFET switching on the buck-boost converter also stops immediately. VLOB indicates the low side boost output from the SM72295.

## ANALOG INPUT

An equivalent circuit for one of the ADC input channels is shown in [Figure 9](#). Diode D1 and D2 provide ESD protection for the analog inputs. The operating range for the analog inputs is 0V to  $V_A$ . Going beyond this range will cause the ESD diodes to conduct and result in erratic operation.

The capacitor C1 in [Figure 9](#) has a typical value of 3 pF and is mainly the package pin capacitance. Resistor R1 is the on resistance of the multiplexer and track / hold switch; it is typically 500Ω. Capacitor C2 is the ADC sampling capacitor; it is typically 30 pF. The ADC will deliver best performance when driven by a low-impedance source (less than 100Ω). This is

specially important when sampling dynamic signals. Also important when sampling dynamic signals is a band-pass or low-pass filter which reduces harmonic and noise in the input. These filters are often referred to as anti-aliasing filters.

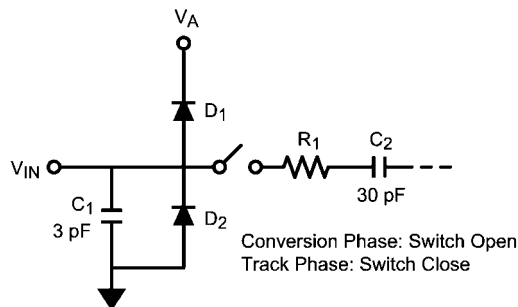

30134309

FIGURE 9. Equivalent Input Circuit

## DIGITAL INPUTS and OUTPUTS

The digital input signals have an operating range of 0V to  $V_A$ , where  $V_A = V_{DDA} - V_{SSA}$ . They are not prone to latch-up and may be asserted before the digital supply  $V_D$ , where  $V_D = V_{DDD} - V_{SSD}$ , without any risk. The digital output signals operating range is controlled by  $V_D$ . The output high voltage is  $V_D - 0.5V$  (min) while the output low voltage is 0.4V (max).

## SDA and SCL OPEN DRAIN OUTPUT

SCL and SDA output is an open-drain output and does not have internal pull-ups. A "high" level will not be observed on this pin until pull-up current is provided by some external source, typically a pull-up resistor. Choice of resistor value depends on many system factors; load capacitance, trace length, etc. A typical value of pull-up resistor for SM72442 ranges from 2 kΩ to 10 kΩ. For more information, refer to the I2C Bus specification for selecting the pull-up resistor value. The SCL and SDA outputs can operate while being pulled up to 5V and 3.3V.

## I2C CONFIGURATION REGISTERS

The operation of the SM72442 can be configured through its I2C interface. Complete register settings for I2C lines are shown below.

### reg0 Register Description

Bits	Field	Reset Value	R/W	Bit Field Description
55:40	RSVD	16'h0	R	Reserved for future use.
39:30	ADC6	10'h0	R	Analog Channel 6 (slew rate detection time constant, see adc config worksheet)
29:20	ADC4	10'h0	R	Analog Channel 4 (iout_max: maximum allowed output current)
19:10	ADC2	10'h0	R	Analog Channel 2 (operating mode, see adc_config worksheet)
9:0	ADC0	10'h0	R	Analog Channel 0 (vout_max: maximum allowed output voltage)

### reg1 Register Description

Bits	Field	Reset Value	R/W	Bit Field Description
55:43	RSVD	13'h0	R	Reserved for future use.
42	burnin_n	1'h0	R	over temperature input to IC

**reg1 Register Description**

Bits	Field	Reset Value	R/W	Bit Field Description
41	pt_n	1'h0	R	over voltage protection input to IC
40	mppt_ok	1'h0	R	Internal mppt_start signal (test only)
39:30	Vout	10'h0	R	Voltage out
29:20	Iout	10'h0	R	Current out
19:10	Vin	10'h0	R	Voltage in
9:0	Iin	10'h0	R	Current in

**reg3 Register Description**

Bits	Field	Reset Value	R/W	Bit Field Description
55:47	RSVD	9'd0	R/W	Reserved
46	override_adcprog	1'b0	R/W	When set to 1'b1, the below override registers used instead of ADC
45	RSVD	1'b0	R/W	Reserved
44:43	RSVD	2'd0	R/W	Reserved
42	power_thr_sel	1'b0	R/W	Register override alternative for ADC2[9] when reg3[46] is set ( $1/2^{*5}$ or $1/2^{*6}$ )
41:40	bb_in_ptmode_sel	2'd0	R/W	Register override alternative for ADC2[8:7] when reg3[46] is set ( 5%, 10%, 25% or 50% )
39:30	Iout_max	10'd1023	R/W	Register override alternative when reg3[46] is set for maximum current threshold instead of ADC ch4
29:20	Vout_max	10'd1023	R/W	Register override alternative when reg3[46] is set for maximum voltage threshold instead of ADC ch0
19:17	tdoff	3'h3	R/W	Dead time Off Time
16:14	tdon	3'h3	R/W	Dead time On time
13:5	dc_open	9'hFF	R/W	Open loop duty cycle (test only)
4	pass_through_sel	1'b0	R/W	Overrides PM pin 28 and use reg3[3]
3	pass_through_manual	1'b0	R/W	Control Panel Mode when pass_through_sel bit is 1'b1
2	bb_reset	1'b0	R/W	Soft reset
1	clk_oe_manual	1'b0	R/W	Enable the PLL clock to appear on pin 5
0	Open Loop operation	1'b0	R/W	Open Loop operation (MPPT disabled, receives duty cycle command from reg 3b13:5); set to 1 and then assert & deassert bb_reset to put the device in openloop (test only)

**reg4 Register Description**

Bits	Field	Reset Value	R/W	Bit Field Description
55:32	RSVD	24'd0	R/W	Reserved
31:24	Vout offset	8'h0	R/W	Voltage out offset
23:16	Iout offset	8'h0	R/W	Current out offset
15:8	Vin offset	8'h0	R/W	Voltage in offset
7:0	Iin offset	8'h0	R/W	Current in offset

**reg5 Register Description**

Bits	Field	Reset Value	R/W	Bit Field Description
55:40	RSVD	15'd0	R/W	Reserved
39:30	Iin_hi_th	10'd40	R/W	Current in high threshold for start
29:20	Iin_lo_th	10'd24	R/W	Current in low threshold for start
19:10	Iout_hi_th	10'd40	R/W	Current out high threshold for start
9:0	Iout_lo_th	10'd24	R/W	Current out low threshold for start

Using the I2C port, the user will be able to control the duty cycle of the PWM signal. Input and output voltage and current offset can also be controlled using I2C on register 4. Control registers are available for additional flexibility.

The thresholds *iin\_hi\_th*, *iin\_lo\_th*, *iout\_hi\_th*, *iout\_lo\_th*, in *reg5* are compared to the values read in by the ADC on the AIIN and AIOU pins. Scaling is set by the scaling of the analog signal fed into AIIN and AIOU. These 10-bit values determine the entry and exit conditions for MPPT.

**COMMUNICATING WITH THE SM72442**

The SCL line is an input, the SDA line is bidirectional, and the device address can be set by I2C0, I2C1 and I2C2 pins. Three device address pins allow connection of up to 7 SM72444s to the same I2C master. A pull-up resistor (10k) to a 5V supply is used to set a bit 1 on the device address. Device addressing for slaves are as follows:

I2C0	I2C1	I2C2	Hex
0	0	1	0x1
0	1	0	0x2
0	1	1	0x3
1	0	0	0x4
1	0	1	0x5
1	1	0	0x6
1	1	1	0x7

The data registers in the SM72442 are selected by the Command Register. The Command Register is offset from base address 0xE0. Each data register in the SM72442 falls into one of two types of user accessibility:

- 1) Read only (Reg0, Reg1)
- 2) Write/Read same address (Reg3, Reg4, Reg5)

There are 7 bytes in each register (56 bits), and data must be read and written in blocks of 7 bytes. *Figure 10* depicts the ordering of the bytes transmitted in each frame and the bits within each byte. In the read sequence depicted in *Figure 11* the data bytes are transmitted in Frames 5 through 11, starting from the LSByte, DATA1, and ending with MSByte, DATA7. In the write sequence depicted in *Figure 12*, the data bytes are transmitted in Frames 4 through 11. Only the 100kHz data rate is supported. Please refer to "The I2C Bus Specification" version 2.1 (Doc#: 939839340011) for more documentation on the I2C bus.

**7 Byte Data Frame:**



**Each Byte contains 8 bits data:**

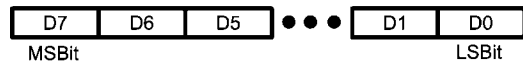

30134316

**FIGURE 10. Endianness Diagram**

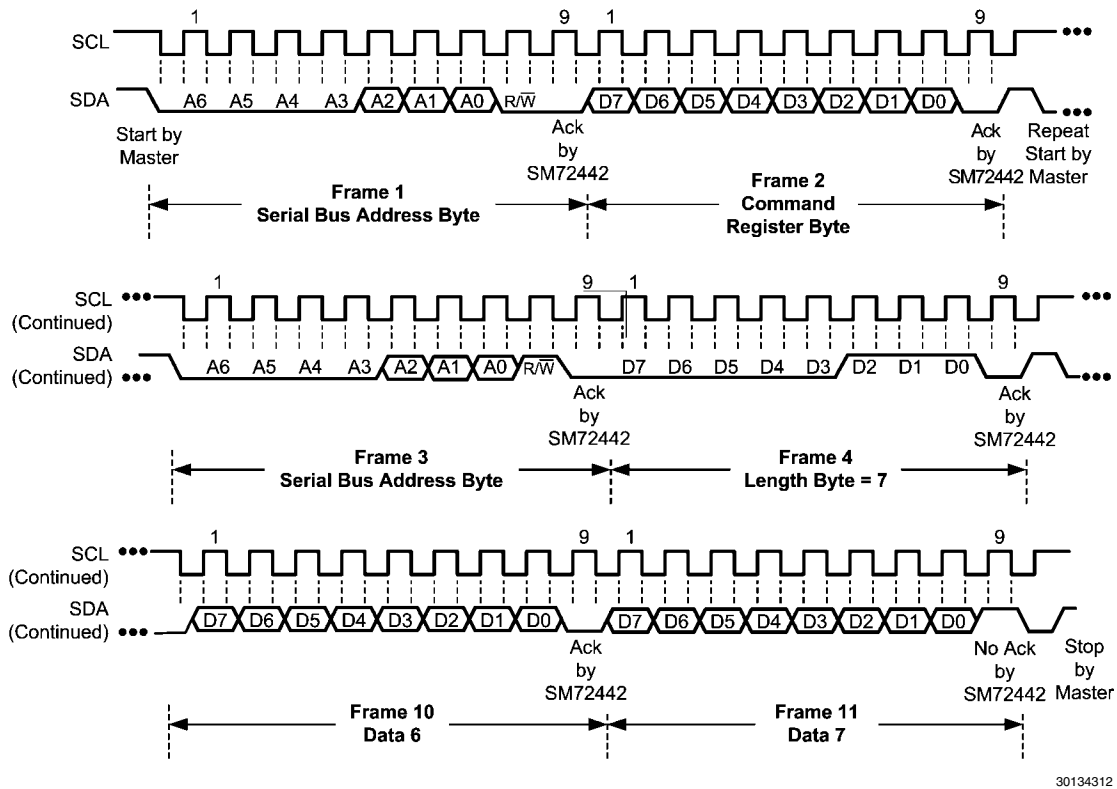

30134312

**FIGURE 11. I2C Read Sequence**

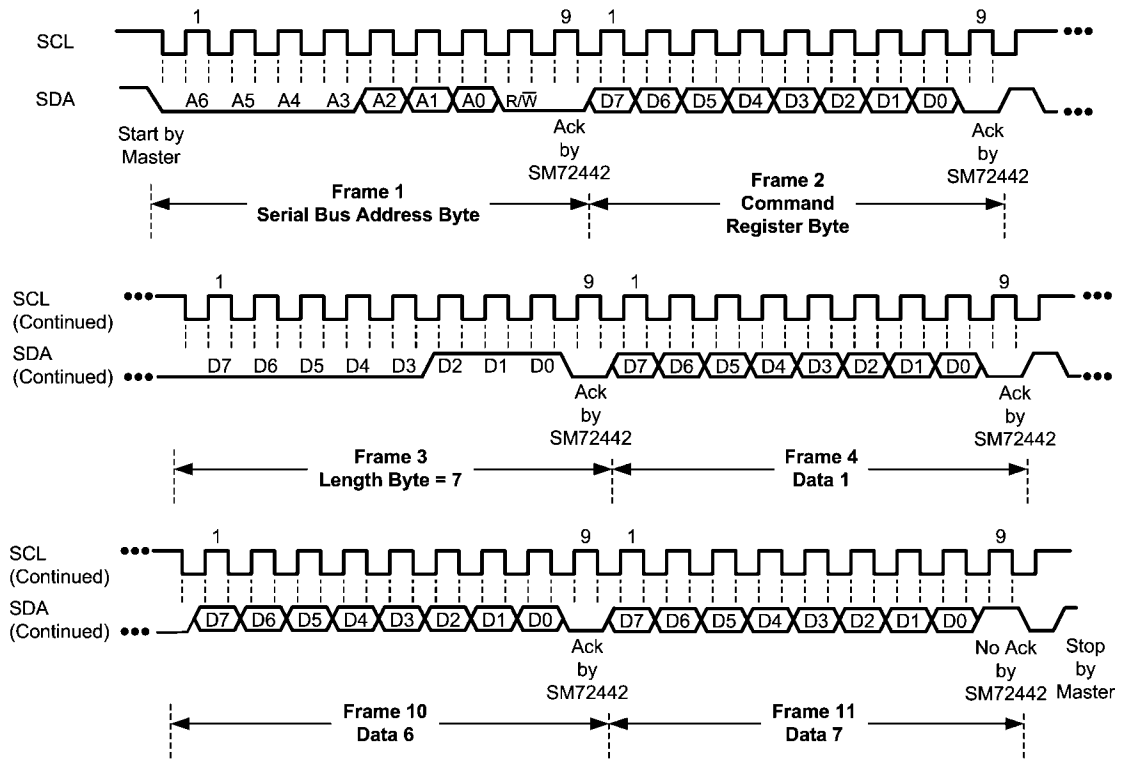

30134314

FIGURE 12. I2C Write Sequence

Noise coupling into digital lines greater than 400 mVp-p (typical hysteresis) and undershoot less than 500 mV GND, may prevent successful I2C communication with SM72442. I2C no acknowledge is the most common symptom, causing unnecessary traffic on the bus although the I2C maximum frequency of communication is rather low (400 kHz max), care still needs to be taken to ensure proper termination within a system with

multiple parts on the bus and long printed board traces. Additional resistance can be added in series with the SDA and SCL lines to further help filter noise and ringing. Minimize noise coupling by keeping digital traces out of switching power supply areas as well as ensuring that digital lines containing high speed data communications cross at right angles to the SDA and SCL lines.

# Physical Dimensions

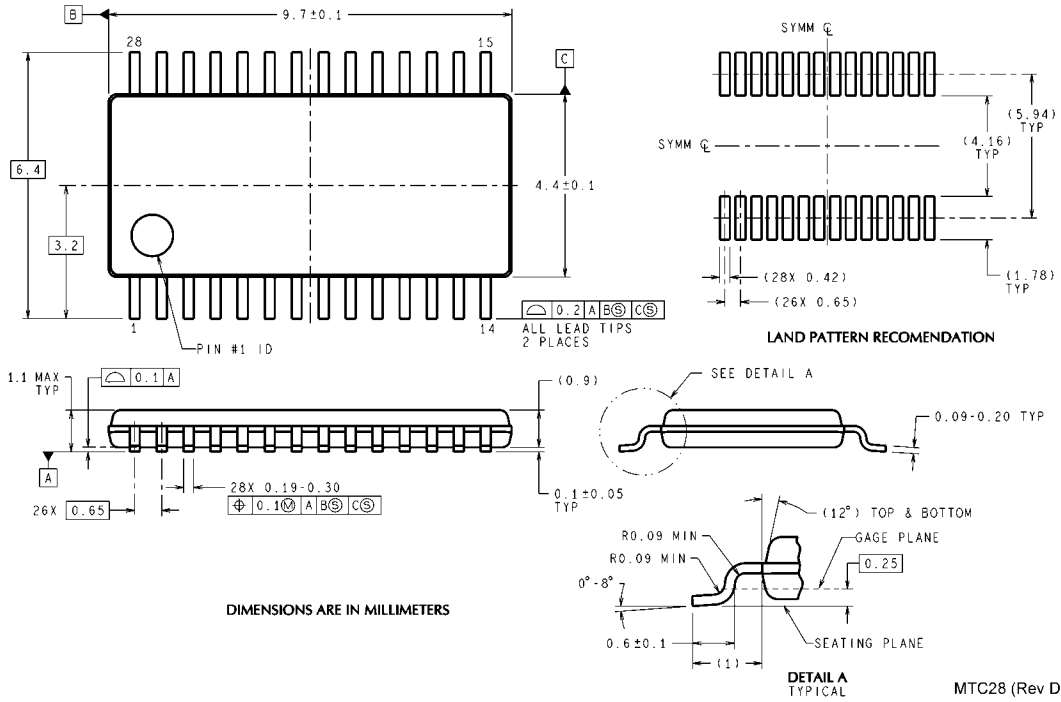

DIMENSIONS ARE IN MILLIMETERS

**NS Package Drawing MTC28**

For more National Semiconductor product information and proven design tools, visit the following Web sites at:  
[www.national.com](http://www.national.com)

Products		Design Support	
Amplifiers	<a href="http://www.national.com/amplifiers">www.national.com/amplifiers</a>	WEBENCH® Tools	<a href="http://www.national.com/webench">www.national.com/webench</a>
Audio	<a href="http://www.national.com/audio">www.national.com/audio</a>	App Notes	<a href="http://www.national.com/appnotes">www.national.com/appnotes</a>
Clock and Timing	<a href="http://www.national.com/timing">www.national.com/timing</a>	Reference Designs	<a href="http://www.national.com/refdesigns">www.national.com/refdesigns</a>
Data Converters	<a href="http://www.national.com/adc">www.national.com/adc</a>	Samples	<a href="http://www.national.com/samples">www.national.com/samples</a>
Interface	<a href="http://www.national.com/interface">www.national.com/interface</a>	Eval Boards	<a href="http://www.national.com/evalboards">www.national.com/evalboards</a>
LVDS	<a href="http://www.national.com/lvds">www.national.com/lvds</a>	Packaging	<a href="http://www.national.com/packaging">www.national.com/packaging</a>
Power Management	<a href="http://www.national.com/power">www.national.com/power</a>	Green Compliance	<a href="http://www.national.com/quality/green">www.national.com/quality/green</a>
Switching Regulators	<a href="http://www.national.com/switchers">www.national.com/switchers</a>	Distributors	<a href="http://www.national.com/contacts">www.national.com/contacts</a>
LDOs	<a href="http://www.national.com/ldo">www.national.com/ldo</a>	Quality and Reliability	<a href="http://www.national.com/quality">www.national.com/quality</a>
LED Lighting	<a href="http://www.national.com/led">www.national.com/led</a>	Feedback/Support	<a href="http://www.national.com/feedback">www.national.com/feedback</a>
Voltage References	<a href="http://www.national.com/vref">www.national.com/vref</a>	Design Made Easy	<a href="http://www.national.com/easy">www.national.com/easy</a>
PowerWise® Solutions	<a href="http://www.national.com/powerwise">www.national.com/powerwise</a>	Applications & Markets	<a href="http://www.national.com/solutions">www.national.com/solutions</a>
Serial Digital Interface (SDI)	<a href="http://www.national.com/sdi">www.national.com/sdi</a>	Mil/Aero	<a href="http://www.national.com/milaero">www.national.com/milaero</a>
Temperature Sensors	<a href="http://www.national.com/tempensors">www.national.com/tempensors</a>	SolarMagic™	<a href="http://www.national.com/solarmagic">www.national.com/solarmagic</a>
PLL/VCO	<a href="http://www.national.com/wireless">www.national.com/wireless</a>	PowerWise® Design University	<a href="http://www.national.com/training">www.national.com/training</a>

THE CONTENTS OF THIS DOCUMENT ARE PROVIDED IN CONNECTION WITH NATIONAL SEMICONDUCTOR CORPORATION ("NATIONAL") PRODUCTS. NATIONAL MAKES NO REPRESENTATIONS OR WARRANTIES WITH RESPECT TO THE ACCURACY OR COMPLETENESS OF THE CONTENTS OF THIS PUBLICATION AND RESERVES THE RIGHT TO MAKE CHANGES TO SPECIFICATIONS AND PRODUCT DESCRIPTIONS AT ANY TIME WITHOUT NOTICE. NO LICENSE, WHETHER EXPRESS, IMPLIED, ARISING BY ESTOPPEL OR OTHERWISE, TO ANY INTELLECTUAL PROPERTY RIGHTS IS GRANTED BY THIS DOCUMENT.

TESTING AND OTHER QUALITY CONTROLS ARE USED TO THE EXTENT NATIONAL DEEMS NECESSARY TO SUPPORT NATIONAL'S PRODUCT WARRANTY. EXCEPT WHERE MANDATED BY GOVERNMENT REQUIREMENTS, TESTING OF ALL PARAMETERS OF EACH PRODUCT IS NOT NECESSARILY PERFORMED. NATIONAL ASSUMES NO LIABILITY FOR APPLICATIONS ASSISTANCE OR BUYER PRODUCT DESIGN. BUYERS ARE RESPONSIBLE FOR THEIR PRODUCTS AND APPLICATIONS USING NATIONAL COMPONENTS. PRIOR TO USING OR DISTRIBUTING ANY PRODUCTS THAT INCLUDE NATIONAL COMPONENTS, BUYERS SHOULD PROVIDE ADEQUATE DESIGN, TESTING AND OPERATING SAFEGUARDS.

EXCEPT AS PROVIDED IN NATIONAL'S TERMS AND CONDITIONS OF SALE FOR SUCH PRODUCTS, NATIONAL ASSUMES NO LIABILITY WHATSOEVER, AND NATIONAL DISCLAIMS ANY EXPRESS OR IMPLIED WARRANTY RELATING TO THE SALE AND/OR USE OF NATIONAL PRODUCTS INCLUDING LIABILITY OR WARRANTIES RELATING TO FITNESS FOR A PARTICULAR PURPOSE, MERCHANTABILITY, OR INFRINGEMENT OF ANY PATENT, COPYRIGHT OR OTHER INTELLECTUAL PROPERTY RIGHT.

**LIFE SUPPORT POLICY**

**NATIONAL'S PRODUCTS ARE NOT AUTHORIZED FOR USE AS CRITICAL COMPONENTS IN LIFE SUPPORT DEVICES OR SYSTEMS WITHOUT THE EXPRESS PRIOR WRITTEN APPROVAL OF THE CHIEF EXECUTIVE OFFICER AND GENERAL COUNSEL OF NATIONAL SEMICONDUCTOR CORPORATION.** As used herein:

Life support devices or systems are devices which (a) are intended for surgical implant into the body, or (b) support or sustain life and whose failure to perform when properly used in accordance with instructions for use provided in the labeling can be reasonably expected to result in a significant injury to the user. A critical component is any component in a life support device or system whose failure to perform can be reasonably expected to cause the failure of the life support device or system or to affect its safety or effectiveness.

National Semiconductor and the National Semiconductor logo are registered trademarks of National Semiconductor Corporation. All other brand or product names may be trademarks or registered trademarks of their respective holders.

Copyright© 2011 National Semiconductor Corporation

For the most current product information visit us at [www.national.com](http://www.national.com)



**National Semiconductor Americas Technical Support Center**  
 Email: [support@nsc.com](mailto:support@nsc.com)  
 Tel: 1-800-272-9959

**National Semiconductor Europe Technical Support Center**  
 Email: [europe.support@nsc.com](mailto:europe.support@nsc.com)

**National Semiconductor Asia Pacific Technical Support Center**  
 Email: [ap.support@nsc.com](mailto:ap.support@nsc.com)

**National Semiconductor Japan Technical Support Center**  
 Email: [jpn.feedback@nsc.com](mailto:jpn.feedback@nsc.com)