



### FEATURES

- Supports CableLabs® DOCSIS 3.0/2.0 and EuroDOCSIS 3.0/2.0 specifications for customer premises equipment (CPE) upstream transmission
- 5 V single-supply operation
- Excellent adjacent channel rejection performance
  - 66 dBc ACPR for a single QPSK channel
  - 63 dBc ACPR for 4× QAM64 channels
- Gain programmable in 1 dB steps over a 59 dB range
  - Gain range: –27 dB to +32 dB
- Current-scaled output stage
- Low between-burst output noise level
  - 70 dB mV in 160 kHz bandwidth
- Maintains constant output impedance in enable, disable, and sleep conditions
- Selectable low power modes
  - 12 mA in Tx disable
  - 12 μA in sleep mode (full power-down)
- 3-wire, SPI-compatible interface
- 4 mm × 5 mm 24-lead LFCSP, RoHS compliant

### APPLICATIONS

- DOCSIS 3.0 and EuroDOCSIS cable modems/E-MTAs
- DOCSIS 3.0 set-top boxes
- CATV telephony modems
- Coaxial or twisted pair line drivers

### GENERAL DESCRIPTION

The ADA4320-1 is a high power, ultralow distortion amplifier designed for CATV reverse channel line driving. Its features and specifications make the ADA4320-1 ideally suited for DOCSIS 3.0- and EuroDOCSIS 3.0-based applications. Both gain and output stage current are controlled via a 3-wire (SPI-compatible) interface. A single 8-bit serial word selects one of four available supply current presets and one of sixty gain codes.

The ADA4320-1 has been tailored to address both the high output drive and stringent fidelity requirements of DOCSIS 3.0. The part is able to maintain excellent adjacent channel rejection performance over the full 5 MHz to 85 MHz range, even with multiple bonded channels at maximum specified output levels.

The ADA4320-1 accepts a differential or single-ended input signal. The output is specified for driving a single-ended 75 Ω load through a 4:1 impedance transformer.

#### Rev. A

Information furnished by Analog Devices is believed to be accurate and reliable. However, no responsibility is assumed by Analog Devices for its use, nor for any infringements of patents or other rights of third parties that may result from its use. Specifications subject to change without notice. No license is granted by implication or otherwise under any patent or patent rights of Analog Devices. Trademarks and registered trademarks are the property of their respective owners.

### FUNCTIONAL BLOCK DIAGRAM

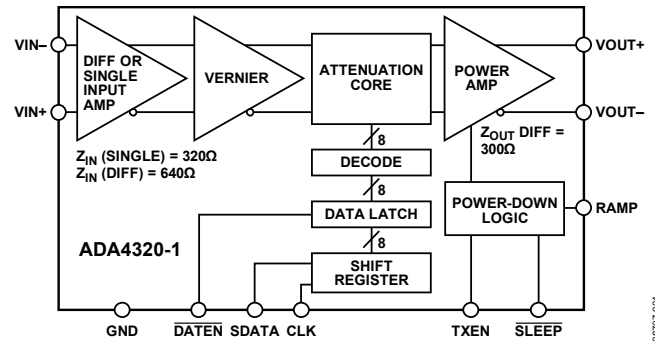

Figure 1.

The ADA4320-1 features an output driver stage that scales quiescent current consumption according to gain setting. In multichannel mode at maximum gain (32 dB), the device draws 260 mA from a single 5 V supply, enabling the high power, ultralow distortion performance required by multiple DOCSIS 3.0 upstream channels. For lifeline E-MTA applications, the ADA4320-1 output stage current can be throttled via SPI commands, reducing the power requirement for single-channel transmission by up to 30%. In transmit-disable mode, the ADA4320-1 draws only 12 mA. The device also features a full power-down sleep mode that further reduces current draw to 12 μA typical.

The ADA4320-1 is packaged in a RoHS-compliant, 24-lead exposed pad LFCSP and is rated for operation over the –40°C to +85°C temperature range.

# ADA4320-1\* Product Page Quick Links

Last Content Update: 11/01/2016

---

## [Comparable Parts](#)

View a parametric search of comparable parts

## [Evaluation Kits](#)

- ADA4320-1 Evaluation Board

## [Documentation](#)

### **Data Sheet**

- ADA4320-1: Low Distortion, DOCSIS 3.0, Upstream CATV Line Driver Data Sheet

## [Design Resources](#)

- ADA4320-1 Material Declaration
- PCN-PDN Information
- Quality And Reliability
- Symbols and Footprints

## [Discussions](#)

View all ADA4320-1 EngineerZone Discussions

## [Sample and Buy](#)

Visit the product page to see pricing options

## [Technical Support](#)

Submit a technical question or find your regional support number

---

## TABLE OF CONTENTS

Features .....	1	General Applications .....	11
Applications.....	1	Circuit Description .....	11
Functional Block Diagram .....	1	Programming.....	11
General Description .....	1	Current Level and Gain Adjustment .....	11
Revision History .....	2	Power Saving Features .....	12
Specifications.....	3	Input Bias, Impedance, and Termination.....	12
Logic Inputs (TTL-/CMOS-Compatible Logic).....	4	Output Bias, Impedance, and Termination .....	12
Timing Requirements .....	5	Power Supply.....	12
Absolute Maximum Ratings.....	6	Signal Integrity Layout Considerations.....	12
Thermal Resistance .....	6	Initial Power-Up .....	12
Maximum Power Dissipation .....	6	RAMP Pin Feature .....	13
ESD Caution.....	6	Output Transformer.....	13
Pin Configuration and Function Descriptions.....	7	Outline Dimensions .....	14
Typical Performance Characteristics .....	8	Ordering Guide .....	14
Applications Information .....	11		

## REVISION HISTORY

### 10/10—Rev. 0 to Rev. A

Changes to Product Title .....	1
Changes to Pin 14, Description, Table 6.....	7
Changes to Current Level and Gain Adjustment Section .....	11
Changes to Output Bias, Impedance, and Termination Section.....	12
Changes to Figure 24.....	13
Changes to Ordering Guide .....	14

### 4/10—Revision 0: Initial Version

## SPECIFICATIONS

T<sub>A</sub> = 25°C, V<sub>S</sub> = 5 V, R<sub>L</sub> = 75 Ω, V<sub>IN</sub> (differential) = 29 dB mV sinusoidal, f = 5 MHz to 85 MHz, gain, V<sub>OUT</sub> (single-ended) measured at output of Coilcraft PWB-4-BL transformer, unless otherwise noted.

Table 1.

Parameter	Conditions	Min	Typ	Max	Unit
<b>INPUT CHARACTERISTICS</b>					
Input Resistance	Balanced (differential) input		640		Ω
	Unbalanced (single-ended) input		320		Ω
Input Capacitance			2.0		pF
<b>GAIN CONTROL</b>					
	Current Level 3				
Gain Range		57.5	59	60	dB
Maximum Gain	Gain Code 60	30.5	32		dB
Minimum Gain	Gain Code 01		-27	-25.5	dB
Output Step Size		0.6	1.0	1.4	dB/LSB
<b>OUTPUT CHARACTERISTICS</b>					
Gain Flatness	Referenced to 10 MHz				
	At Maximum Gain	f = 42 MHz, Gain Code 60, Current Level 3		-0.3	dB
		f = 65 MHz, Gain Code 60, Current Level 3		-0.7	dB
		f = 85 MHz, Gain Code 60, Current Level 3		-1.1	dB
At Minimum Gain		f = 42 MHz, Gain Code 01, Current Level 0		-0.4	dB
		f = 65 MHz, Gain Code 01, Current Level 0		-0.8	dB
		f = 85 MHz, Gain Code 01, Current Level 0		-1.8	dB
1 dB Compression Point (P <sub>1dB</sub> )	f = 10 MHz, Gain Code 60, Current Level 3, output referred		70		dB mV
Output Noise in 160 kHz Bandwidth	f = 10 MHz, 294 Ω resistor across VIN+ and VIN- pins				
	At Maximum Gain	Gain Code 60, Current Level 3, TXEN = high (1)	-19	-20	dB mV
		Gain Code 60, Current Level 0, TXEN = high (1)	-20	-21	dB mV
At Minimum Gain		Gain Code 01, Current Level 3, TXEN = high (1)	-59	-60	dB mV
		Gain Code 01, Current Level 0, TXEN = high (1)	-60	-61	dB mV
Transmit Disabled	TXEN = low (0)	-68	-70		dB mV
Output Impedance (Measured at Transformer Output)	TXEN = high (1) or TXEN = low (0) or $\overline{\text{SLEEP}}$ = low (0)		75		Ω
Output Return Loss (Measured at Transformer Output)	f = 85 MHz				
	$\overline{\text{SLEEP}}$ = high (1), TXEN = high (1)		12		dB
	$\overline{\text{SLEEP}}$ = high (1), TXEN = low (0)		11		dB
	$\overline{\text{SLEEP}}$ = low (0)		10		dB
<b>OVERALL PERFORMANCE</b>					
Adjacent Channel Power Ratio (ACPR)	Single QPSK Channel	f = 5 MHz to 85 MHz, output level = 61 dB mV, Gain Code 60, Current Level 3, channel width = 6.4 MHz, adjacent channel width = 6.4 MHz		-66	dBc
		4x QAM64 Channels	f = 5 MHz to 85 MHz, output level = 53 dB mV/channel, Gain Code 60, Current Level 3, channel width = 1.6 MHz, adjacent channel width = 1.6 MHz		-63
Output Third-Order Intercept Point (OIP3)	f <sub>1</sub> = 84 MHz, f <sub>2</sub> = 85 MHz, Gain Code 60, Current Level 3		93		dB mV
	f <sub>1</sub> = 84 MHz, f <sub>2</sub> = 85 MHz, Gain Code 60, Current Level 0		87		dB mV
Input-to-Output Isolation	f = 85 MHz, Gain Code 60, TXEN = Low (0)		107		dB

# ADA4320-1

Parameter	Conditions	Min	Typ	Max	Unit	
<b>POWER CONTROL</b>						
Transmit Enable Settling Time	TXEN = 0 to 1, Gain Code 60, no input signal		5.5		μs	
Transmit Disable Settling Time	TXEN = 1 to 0, Gain Code 60, no input signal		7		μs	
Output Switching Transients	Gain Code 60		20		mV p-p	
	Gain Code 01		2		mV p-p	
<b>POWER SUPPLY</b>						
Operating Range		4.75	5.00	5.25	V	
Quiescent Current At Maximum Gain	Gain Code 60, Current Level 3		260	300	mA	
	Gain Code 60, Current Level 2		235	270	mA	
	Gain Code 60, Current Level 1		210	250	mA	
	Gain Code 60, Current Level 0		180	210	mA	
	At Minimum Gain	Gain Code 01, Current Level 3		77	100	mA
		Gain Code 01, Current Level 2		73	95	mA
		Gain Code 01, Current Level 1		70	90	mA
		Gain Code 01, Current Level 0		65	80	mA
		TXEN = 0, all gain codes, all current levels		12	15	mA
$\overline{\text{SLEEP}} = 0$ (power-down)		12	80	μA		
<b>OPERATING TEMPERATURE RANGE</b>		-40		+85	°C	

## LOGIC INPUTS (TTL-/CMOS-COMPATIBLE LOGIC)

$\overline{\text{DATEN}}$ , CLK, SDATA, TXEN,  $\overline{\text{SLEEP}}$ ,  $V_s = 5\text{ V}$ ; full temperature range.

Table 2.

Parameter	Min	Typ	Max	Unit
Logic 1 Voltage	2.0		$V_s$	V
Logic 0 Voltage	0		0.8	V
Digital Input Leakage Current (Both Logic Levels, All Digital Pins)	-5		+5	μA

**TIMING REQUIREMENTS**

Full temperature range,  $V_{CC} = 5\text{ V}$ ,  $t_R = t_F = 4\text{ ns}$ ,  $f_{CLK} = 8\text{ MHz}$ , unless otherwise noted.

**Table 3.**

Parameter	Min	Typ	Max	Unit
Clock Pulse Width ( $t_{WH}$ )	16			ns
Clock Period ( $t_c$ )	32			ns
Setup Time $\overline{SDATA}$ vs. Clock ( $t_{DS}$ )	5			ns
Setup Time $\overline{DATEN}$ vs. Clock ( $t_{ES}$ )	16			ns
Hold Time $\overline{SDATA}$ vs. Clock ( $t_{DH}$ )	5			ns
Hold Time $\overline{DATEN}$ vs. Clock ( $t_{EH}$ )	3			ns
Input 10% to 90% Rise and Fall Times, $\overline{SDATA}$ , $\overline{DATEN}$ , Clock			10	ns

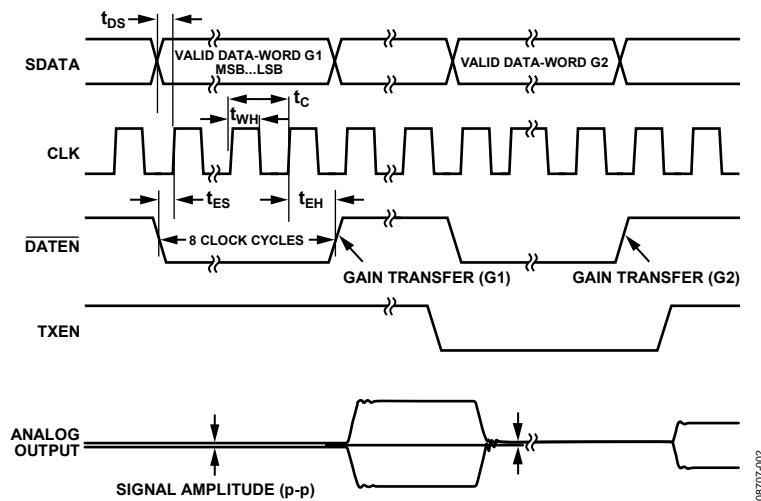

Figure 2. Serial Interface Timing

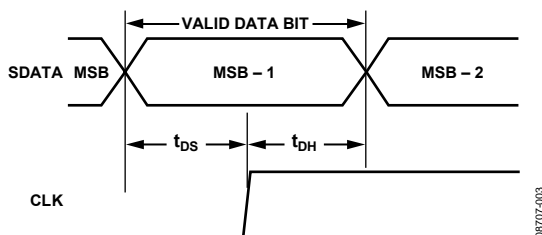

Figure 3.  $\overline{SDATA}$  Timing

## ABSOLUTE MAXIMUM RATINGS

Table 4.

Parameter	Rating
Supply Voltage	5.5 V
Maximum Power Dissipation	1.65 W
Storage Temperature Range	-65°C to +125°C
Operating Temperature Range	-40°C to +85°C
Lead Temperature (Soldering, 10 sec)	300°C
Junction Temperature	150°C

Stresses above those listed under Absolute Maximum Ratings may cause permanent damage to the device. This is a stress rating only; functional operation of the device at these or any other conditions above those indicated in the operational section of this specification is not implied. Exposure to absolute maximum rating conditions for extended periods may affect device reliability.

### THERMAL RESISTANCE

$\theta_{JA}$  is specified for the device soldered to a high thermal conductivity 4-layer (2s2p) circuit board, as described in EIA/JESD 51-7.

Table 5. Thermal Resistance

Package Type	$\theta_{JA}$	$\theta_{JC}$	Unit
24-lead LFCSP	31.2	5.7	°C/W

### MAXIMUM POWER DISSIPATION

The maximum safe power dissipation in the ADA4320-1 package is limited by the associated rise in junction temperature ( $T_j$ ) on the die. At approximately 150°C, which is the glass transition temperature, the plastic changes its properties. Even temporarily exceeding this temperature limit can change the stresses that the package exerts on the die, permanently shifting the parametric performance of the ADA4320-1. Exceeding a junction temperature of 150°C for an extended time can result in changes in the silicon devices, potentially causing failure.

Airflow increases heat dissipation, effectively reducing  $\theta_{JA}$ . In addition, more metal directly in contact with the package leads from metal traces, through-holes, ground, and power planes, reduces the  $\theta_{JA}$ . The exposed paddle on the underside of the package must be soldered to a pad on the PCB surface that is thermally connected to a copper plane to achieve the specified  $\theta_{JA}$ .

### ESD CAUTION



**ESD (electrostatic discharge) sensitive device.** Charged devices and circuit boards can discharge without detection. Although this product features patented or proprietary protection circuitry, damage may occur on devices subjected to high energy ESD. Therefore, proper ESD precautions should be taken to avoid performance degradation or loss of functionality.

## PIN CONFIGURATION AND FUNCTION DESCRIPTIONS

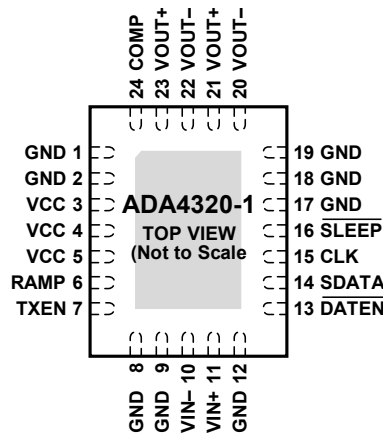

**NOTES**  
 1. EXPOSED THERMAL PAD MUST BE ELECTRICALLY AND THERMALLY CONNECTED TO PCB GROUND (GND) PLANE.

08707-005

Figure 4. Pin Configuration, Top View

Table 6. Pin Function Descriptions

Pin No.	Mnemonic	Description
1, 2, 8, 9, 12, 17, 18, 19, EPAD	GND	Common External Ground Reference.
3, 4, 5	VCC	Common Positive External Supply Voltage.
6	RAMP	External RAMP Capacitor (Optional).
7	TXEN	Transmit Enable. Logic 0 disables forward transmission, and Logic 1 enables forward transmission.
10	VIN-	Inverting Input. DC-biased to approximately $V_{CC}/2$ . This pin should be ac-coupled with a 0.1 $\mu\text{F}$ capacitor.
11	VIN+	Noninverting Input. DC-biased to approximately $V_{CC}/2$ . This pin should be ac-coupled with a 0.1 $\mu\text{F}$ capacitor.
13	DATEN	Data Enable Low Input. This port controls the 8-bit parallel data latch and shift register. A Logic 0-to-1 transition transfers the latched data to the attenuator core (updates the gain) and simultaneously inhibits serial data transfer into the register. A 1-to-0 transition inhibits the data latch (holds the previous, and simultaneously enables the register for serial data load).
14	SDATA	Serial Data Input. This digital input allows an 8-bit serial control word to be loaded into the internal register with the most significant bit (MSB) first to adjust both the gain and current levels.
15	CLK	Clock Input. The clock port controls the serial attenuator data transfer rate to the 8-bit master-slave shift register. A Logic 0-to-1 transition latches the data bit, and a Logic 1-to-0 transition transfers the data bit to the slave. This requires the input serial data-word to be valid at or before this clock transition.
16	SLEEP	Low Power Sleep Mode. In sleep mode, the supply current is reduced to 12 $\mu\text{A}$ typical. Logic 0 powers down the device, and Logic 1 powers up the device.
20, 22	VOUT-	Negative Output Signal. This pin must be biased to $V_{CC}$ .
21, 23	VOUT+	Positive Output Signal. This pin must be biased to $V_{CC}$ .
24	COMP	Internal Compensation. This pin must be externally decoupled (0.1 $\mu\text{F}$ capacitor).



## TYPICAL PERFORMANCE CHARACTERISTICS

$T_A = 25^\circ\text{C}$ ,  $V_S = 5\text{ V}$ ,  $R_L = 75\ \Omega$ ,  $V_{IN}$  (differential) = 29 dBmV sinusoidal,  $f = 5\text{ MHz to }85\text{ MHz}$ , Gain Code 60 (maximum), Current Level 3 (maximum),  $V_{OUT}$  (single-ended) measured at output of Coilcraft PWB-4-BL transformer, unless otherwise noted.

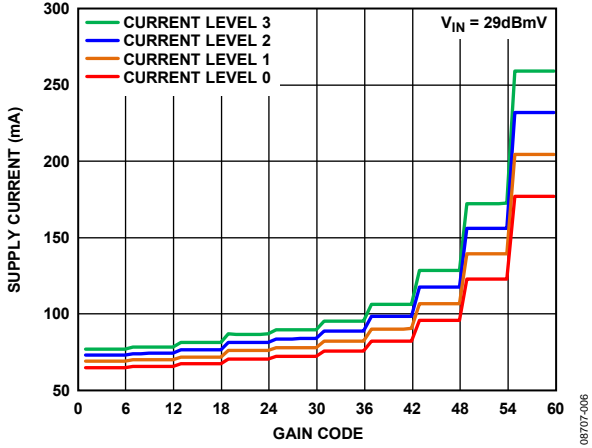

Figure 5. Supply Current vs. Gain Code

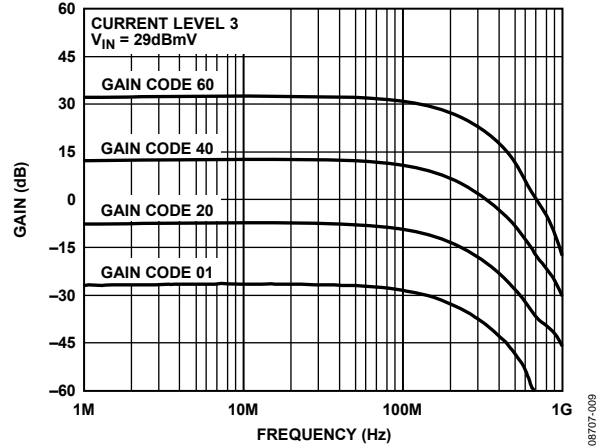

Figure 8. Gain vs. Frequency

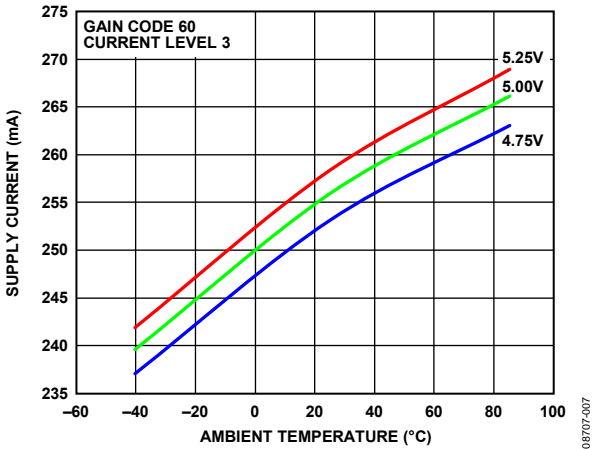

Figure 6. Supply Current vs. Ambient Temperature at Maximum Gain

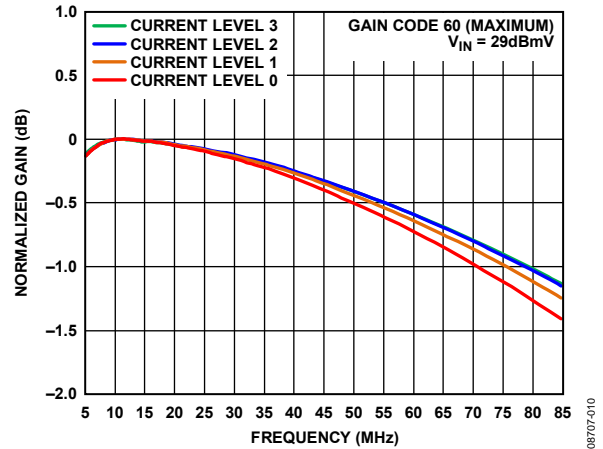

Figure 9. Normalized Frequency Response at Maximum Gain

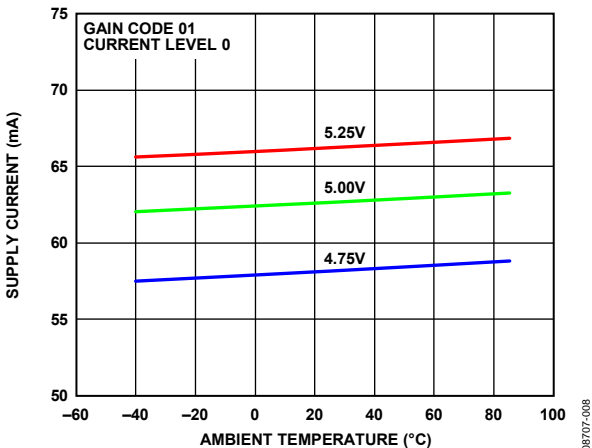

Figure 7. Supply Current vs. Ambient Temperature at Minimum Gain

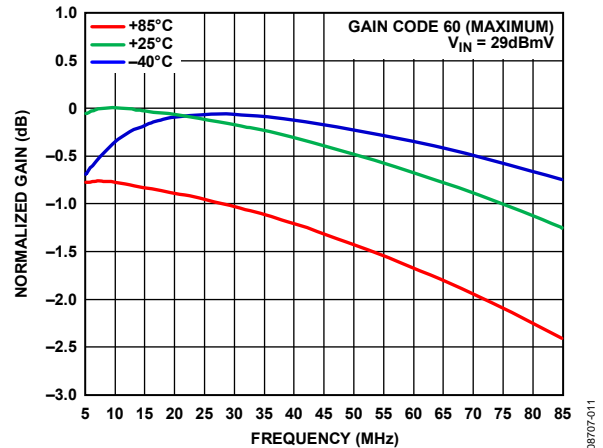

Figure 10. Normalized Frequency Response over Temperature

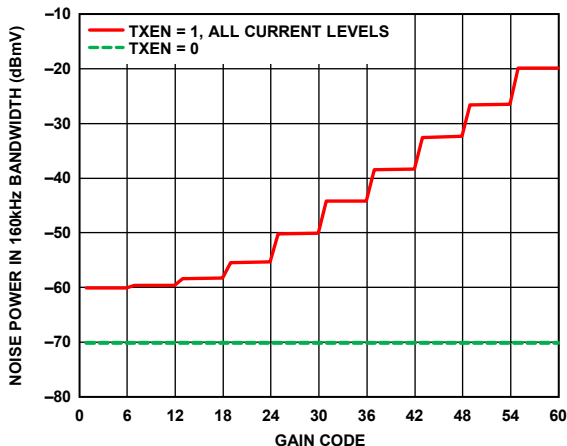

Figure 11. Noise Power vs. Gain Code

08707-013

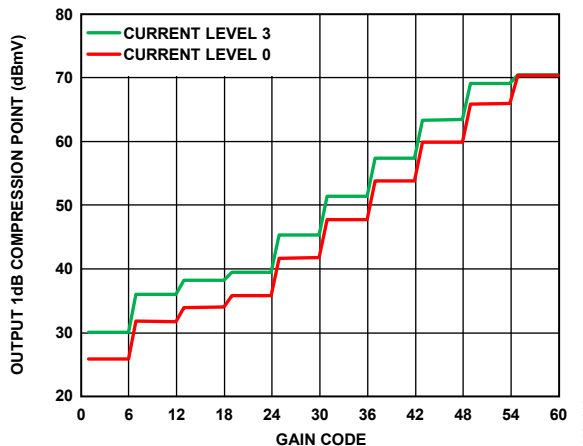

Figure 14. Output 1 dB Compression Point vs. Gain Code

08707-014

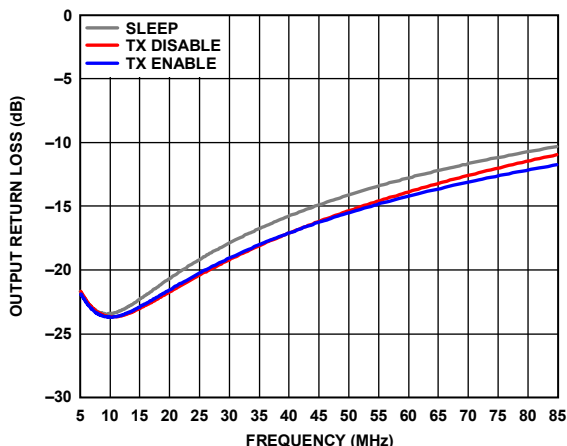

Figure 12. Output Return Loss (S22) vs. Frequency

08707-012

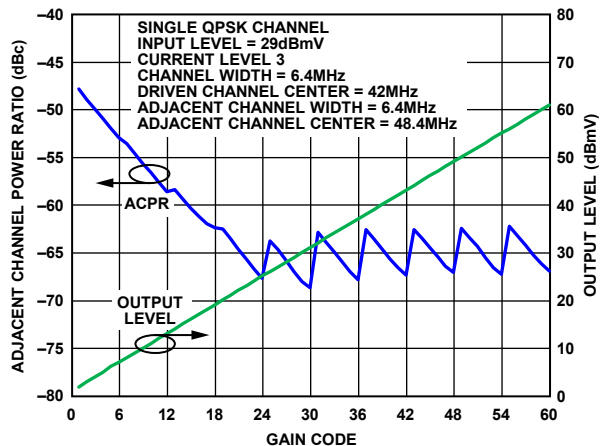

Figure 15. ACPR and Output Level vs. Gain Code

08707-017

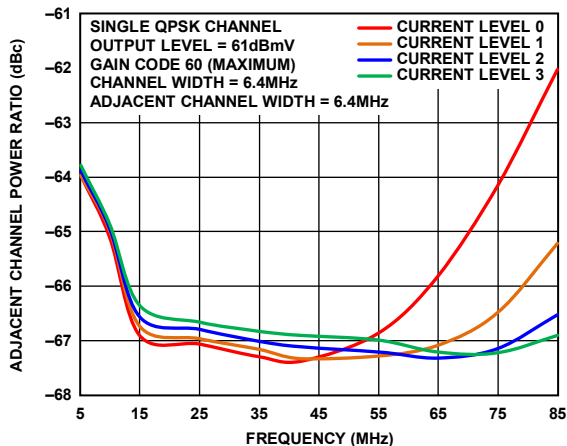

Figure 13. ACPR vs. Frequency for Single QPSK Channel

08707-015

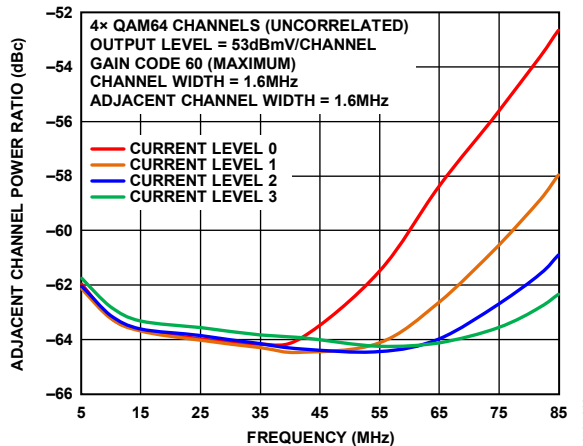

Figure 16. ACPR vs. Frequency for 4x QAM64 Channels

08707-016

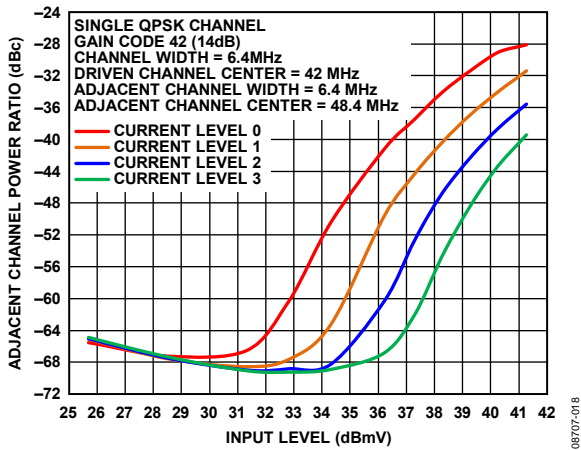

Figure 17. ACPR vs. Input Level for a Single QPSK Channel

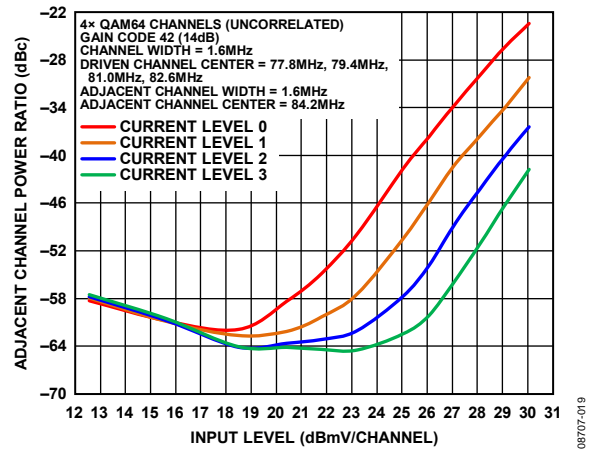

Figure 20. ACPR vs. Input Level for 4x QAM64 Channels

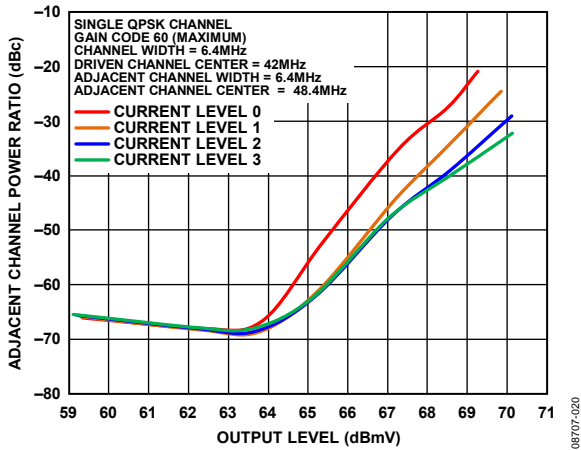

Figure 18. ACPR vs. Output Level for a Single QPSK Channel

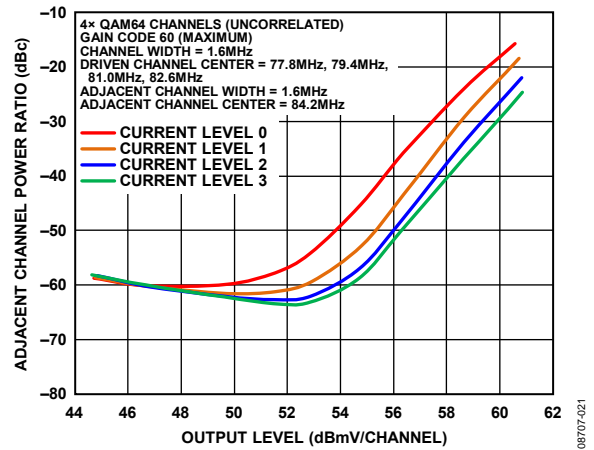

Figure 21. ACPR vs. Output Level for 4x QAM64 Channels

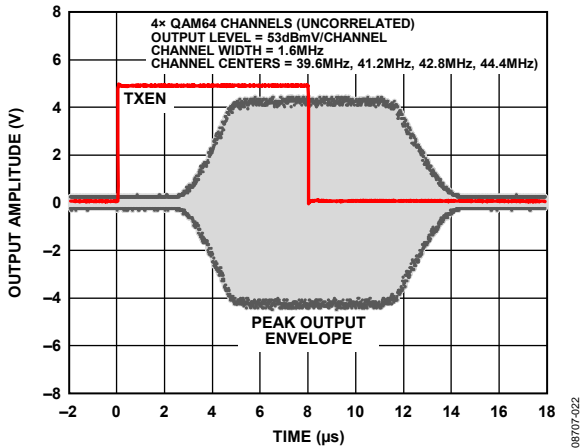

Figure 19. Transmit Enable/Disable Response

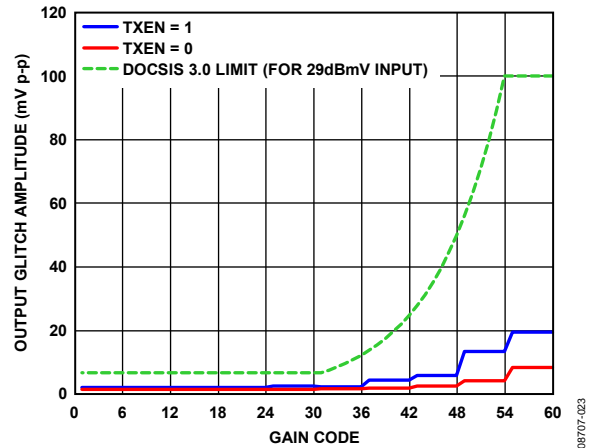

Figure 22. Output Glitch Amplitude vs. Gain Code

## APPLICATIONS INFORMATION

### GENERAL APPLICATIONS

The ADA4320-1 is primarily intended for use as the reverse channel power amplifier (PA) in DOCSIS® 3.0 customer premises equipment (CPE), including cable modems, E-MTAs, and DOCSIS-enabled set-top boxes. The signals are typically QPSK or QAM waveforms generated by the upstream modulator and DAC. To sufficiently attenuate DAC images, a low-pass reconstruction filter is recommended between the DAC output and the ADA4320-1. A differential filter is preferred, and its output impedance should match the 640 Ω input impedance of the ADA4320-1.

Varying distances between the CPE and the cable modem termination system (CMTS), as well as diplexers and splitters that may exist in the signal path, require the amplifier to provide a wide range of output power. The combination of a high output level, excellent linearity, and 59 dB gain range of the ADA4320-1 enables the CPE to overcome inline losses and ensures adequate signal strength at the upstream termination.

### CIRCUIT DESCRIPTION

In power-up mode, the ADA4320-1 comprises three analog functions. The input amplifier (preamp) can be used single-ended or balanced (differential). If the input is used in the balanced configuration, it is imperative that the input signals be 180° out of phase and of equal amplitude. A Vernier adjustment amplifier controls the 1 dB gain steps.

The digital attenuator (DA) stage provides coarse adjustment in 6 dB steps. It also scales the current supplied to the output stage. Both the preamp and DA are differential (balanced) to improve power supply rejection and linearity.

The differential current is output from the DA to the output stage. The output stage, with its 300 Ω balanced output impedance, maintains proper matching to a 75 Ω load when used with a 2:1 (turns ratio) balun transformer.

### PROGRAMMING

The ADA4320-1 is controlled via a unidirectional, 3-wire serial interface (SPI-compatible) consisting of CLK, DATEN, and SDATA signals. An 8-bit data-word containing the output stage current level (Bits[7:6]) and desired gain code (Bits[5:0]) is clocked into the SDATA port, MSB first.

The programmable current level (CL) range of the ADA4320-1 is CL3 (highest) to CL0 (lowest). The programmable gain range is +32 dB (Gain Code 60) to -27 dB (Gain Code 01), in steps of 1 dB per least significant bit (LSB), providing a total gain range of 59 dB.

Table 7. Data-Word for Setting Current and Gain Levels

CL	Typical Current (mA)	CL[7:6] (Bin)	Gain[5:0] (Hex)	Gain Code (Dec)	Typical Gain (dB)
3	260 to 77	11	3C to 01	60 to 01	+32 to -27
2	235 to 73	10	3C to 01	60 to 01	+32 to -27
1	210 to 70	01	3C to 01	60 to 01	+32 to -27
0	180 to 65	00	3C to 01	60 to 01	+32 to -27

The sequence of loading the SDATA register starts on the falling edge of the DATEN pin, which activates the CLK line. Data on the SDATA line is clocked into the serial shift register on the rising edge of CLK, MSB first. The data-word is latched into the attenuator core on the rising edge of DATEN. Serial interface timing for the ADA4320-1 is shown in Figure 2 and Figure 3.

### CURRENT LEVEL AND GAIN ADJUSTMENT

Gain adjustment and current scaling allow the PA to achieve the high output levels and linearity required for multiple-channel DOCSIS 3.0 compliance, while offering significantly reduced power consumption in single-channel and lifeline battery-backup modes of operation.

There are two methods used to adjust the supply current of the ADA4320-1. The four curves in Figure 23 represent the supply current vs. gain code for the different current level (CL3 to CL0). The current levels are selectable using Bit 6 and Bit 7 of the 8-bit control word clocked into the serial data port.

In addition to the selectable current levels, the supply current is automatically reduced for every 6 dB reduction in gain. At higher gain settings, this is more pronounced. At maximum gain setting and maximum current level, a step down of 6 dB reduces the supply current by 33%.

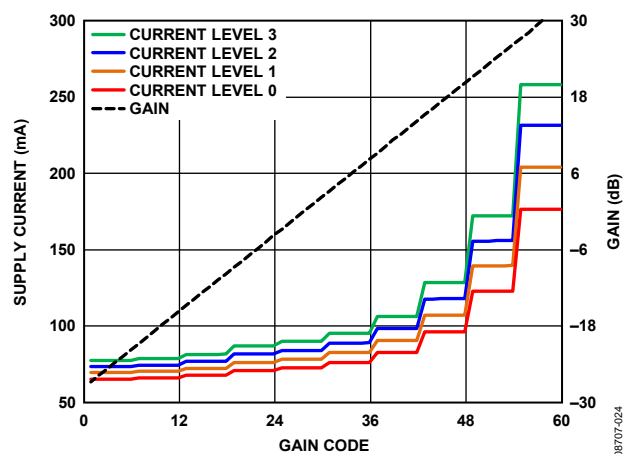

Figure 23. Gain and Current Scaling

# ADA4320-1

## POWER SAVING FEATURES

The ADA4320-1 incorporates three distinct methods for reducing power consumption that include the following:

- Transmit disable for between-burst periods
- Sleep (shutdown) mode
- Output stage current scaling

The asynchronous TXEN pin is used to place the ADA4320-1 into between-burst mode. In this reduced current state, the 300  $\Omega$  differential output impedance is maintained. Applying Logic 0 to the TXEN pin deactivates the amplifier, providing up to 95% reduction in consumed power. For 5 V operation at maximum gain and current level, supply current is typically reduced from 260 mA to 12 mA. In this mode of operation, between-burst noise is minimized and over 100 dB of input to output isolation is achieved.

Additionally, the ADA4320-1 incorporates an asynchronous SLEEP pin that can be used to further reduce supply current to approximately 12  $\mu$ A. Applying Logic 0 to the SLEEP pin places the amplifier into sleep mode.

Entering/exiting sleep mode can result in a transient voltage at the output of the amplifier. It is recommended to perform transitions on the SLEEP pin with TXEN held low.

Additional power savings are possible by optimizing the output stage current for different operating conditions. Typically, at lower frequencies (5 MHz to 42 MHz), the full specified output can be maintained in CL0 (see Figure 13 and Figure 16). For lower input levels, the same is true, as shown in Figure 17 and Figure 20. For per-channel output levels less than 65 dBmV (QPSK) and 50 dBmV (4 $\times$  QAM64), the ADA4320-1 can maintain an ACPR of better than -60 dBc (see Figure 18 and Figure 21) at Current Level 0 (CL0). At higher gain settings, operating in CL0 reduces current consumption by 30%, compared to operating in CL3.

As an example, operating in CL0, the ADA4320-1 can drive a single QPSK channel at 61 dBmV, at maximum gain, maintaining a worst-case ACPR of -66 dBc. It does this while drawing only 180 mA from a 5 V supply.

## INPUT BIAS, IMPEDANCE, AND TERMINATION

The VIN+ and VIN- inputs have a dc bias level of  $V_{CC}/2$ ; therefore, the input signal should be ac-coupled as seen in the typical application circuit (see Figure 24). The differential input impedance of the ADA4320-1 is approximately 640  $\Omega$ , and the single-ended input is 320  $\Omega$ . The ADA4320-1 exhibits optimum performance when driven with a balanced (differential) signal.

## OUTPUT BIAS, IMPEDANCE, AND TERMINATION

The output stage of the ADA4320-1 requires a bias of 5 V. The 5 V power supply should be applied to the center tap of the output transformer through a 100 nH series inductor as shown in Figure 24. The 100 nH inductor should be placed close to the transformer center tap to reduce parasitic capacitance on this node and to obtain best performance.

The output impedance of the ADA4320-1 is 300  $\Omega$  differential, regardless of whether the amplifier is in transmit enable, transmit disable, or sleep mode. This, when combined with a 4:1 impedance transformer, provides a 75  $\Omega$  output match and eliminates the need for external back termination resistors. If the output signal is being evaluated using standard 50  $\Omega$  test equipment, a minimum loss 75  $\Omega$  to 50  $\Omega$  pad should be used to provide the test circuit with the proper impedance match.

## POWER SUPPLY

The 5 V supply should be delivered to each of the VCC pins via a low impedance power bus. The power bus should be decoupled with a 10  $\mu$ F tantalum capacitor located close to the ADA4320-1. Additionally, the VCC pins require decoupling to ground with ceramic chip capacitors located close to the pins. Pin 24 (COMP), should also be decoupled. The ideal printed circuit board (PCB) has a low impedance ground plane covering all unused portions of the board, except in areas of the board where input and output traces are in close proximity to the ADA4320-1 and the output transformer. All device GND pins, as well as the exposed pad, must contact the PCB ground plane to ensure proper grounding of all internal nodes.

## SIGNAL INTEGRITY LAYOUT CONSIDERATIONS

Careful attention to PCB layout details can prevent problems due to board parasitics. Proper RF design techniques are highly recommended. All balanced input/output traces should be kept as short as possible. This minimizes parasitic capacitance and inductance, which is most critical between the outputs of the ADA4320-1 and the 4:1 output transformer. It is also recommended that all balanced signal paths be symmetrical in length and width.

Additionally, input and output traces should be adequately spaced to minimize coupling (crosstalk) through the board. Following these guidelines optimizes the overall performance of the ADA4320-1 in all applications.

## INITIAL POWER-UP

When supply voltage is applied to the ADA4320-1, the gain of the amplifier is initially undetermined. During amplifier power-up, the TXEN pin should be held low (Logic 0) to prevent forward signal transmission. Gain must then be set to the desired level, followed by TXEN driven high. Forward signal transmission is enabled at the resultant gain level.

## RAMP PIN FEATURE

The RAMP pin (Pin 6) can be optionally used to control the length of the burst on and off transients. By default, leaving the RAMP pin unconnected results in a transient that is fully compliant with DOCSIS 3.0. Adding capacitance to the RAMP pin slows the dissipation even more.

## OUTPUT TRANSFORMER

Matching the 300 Ω differential output impedance to unbalanced 75 Ω requires a 4:1 impedance (2:1 turns) ratio transformer. The transformer should have minimal insertion loss over the 5 MHz to 85 MHz band and have a maximum dc current rating of at least 200 mA.

Characterization of the ADA4320-1 was performed using a Coilcraft PWB-4-BL surface-mount wide-band RF transformer. Alternate choices for the output transformer are the Toko 458PT-1565 and the Tyco Electronics (M/A-COM) ABACT0018.

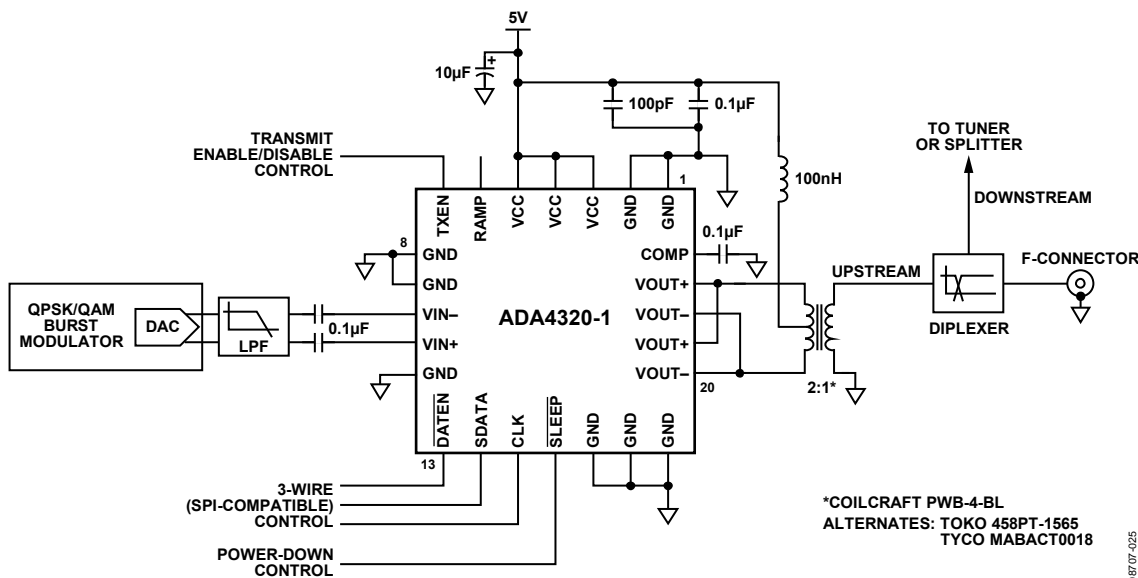

Figure 24. Typical Application

06/07-025

OUTLINE DIMENSIONS

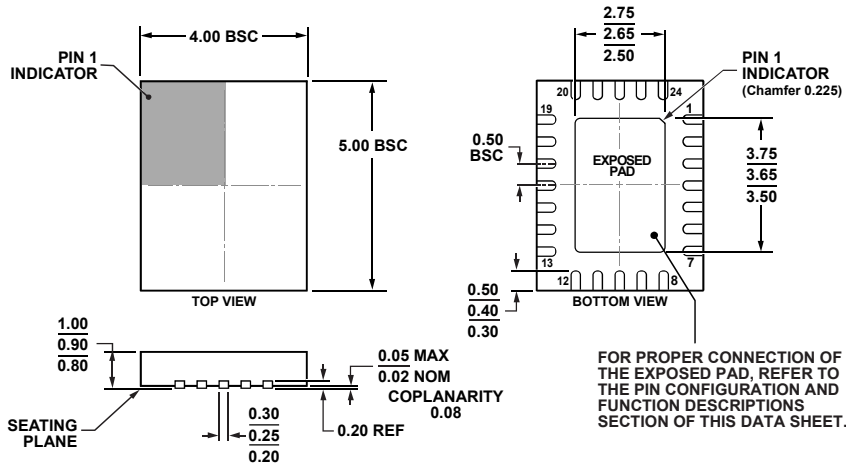

Figure 25. 24-Lead Lead Frame Chip Scale Package [LFCSP\_VQ]  
 4 mm × 5 mm Body, Very Thin Quad  
 (CP-24-5)  
 Dimensions shown in millimeters

ORDERING GUIDE

Model <sup>1</sup>	Temperature Range	Package Description	Package Option	Ordering Quantity
ADA4320-1ACPZ-R7	-40°C to +85°C	24-Lead Lead Frame Chip Scale Package (LFCSP_VQ)	CP-24-5	1,500
ADA4320-1ACPZ-RL	-40°C to +85°C	24-Lead Lead Frame Chip Scale Package (LFCSP_VQ)	CP-24-5	5,000
ADA4320-1ACPZ-EVAL		Evaluation Board		

<sup>1</sup> Z = RoHS Compliant Part.

**NOTES**



**ADA4320-1**

**NOTES**