

## 4 Channel Charge Pump White LED Driver

### FEATURES

- High Efficiency > 90%
- Support up to 4 White LEDs with current matching
- Three Charge Pump Modes: X1, X1.5, X2
- Soft Start Function
- Short Circuit Protection
- Output Overvoltage Protection
- Thermal Shutdown
- Programmable LED drive capability
- PWM Dimming Control
- 1MHz Fixed Frequency Oscillator
- Low 1 $\mu$ A Shutdown Current
- Pin Compatible with SC604

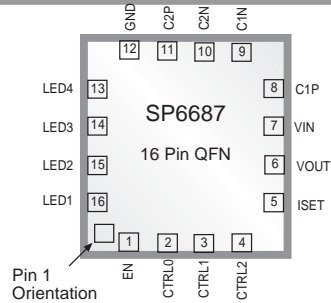

*Now Available in Lead-Free Packaging*

### APPLICATIONS

- Mobile phones
- White LED Backlighting
- Camera Flash LED lighting

### DESCRIPTION

The SP6687 is a compact, highly efficient and highly integrated 4 channel charge pump white LED driver. It can support from 1 to 4 White LEDs and is optimized for Li-Ion battery applications. Current matching allows all 4 LEDs to maintain consistent brightness. Users can control White LEDs by three programming bits. Each channel can support up to 30mA of current. This device is available in a 4mm x 4mm, 16 pin QFN package.

### TYPICAL APPLICATION CIRCUIT

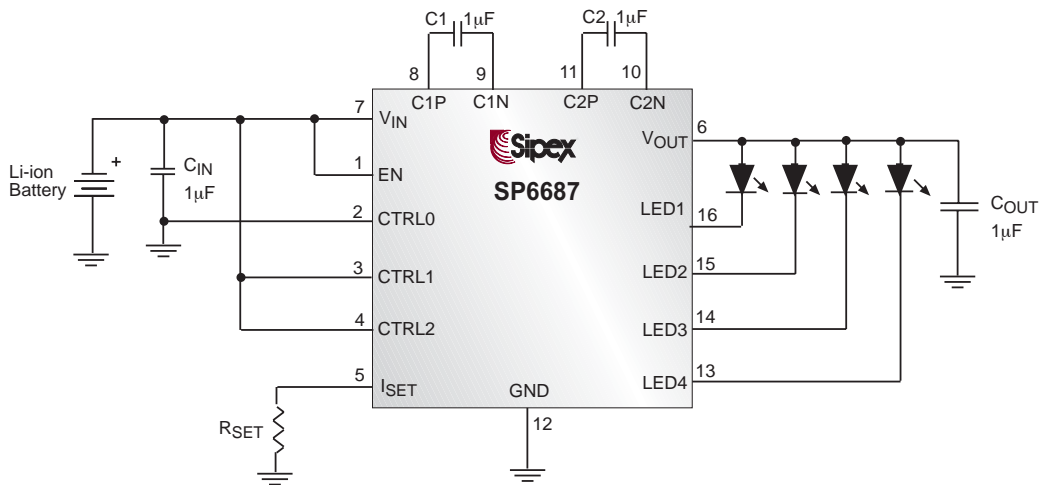

Typical Application Circuit for 4-White LEDs

## ABSOLUTE MAXIMUM RATINGS

These are stress ratings only and functional operation of the device at these ratings or any other above those indicated in the operation sections of the specifications below is not implied. Exposure to absolute maximum rating conditions for extended periods of time may affect reliability.

Input Voltage.....-0.3 to 6V	Junction Temperature Range.....-40°C to 125°C
Output Voltage.....-0.3 to 6V	Storage Temperature .....-65°C to 150°C
Power Dissipation, $P_D$ @ $T_A = 25^\circ\text{C}$	Operating Temperature ..... -40°C to 85°C
QFN-16L 4x4.....2.5W	ESD Susceptibility
Package Thermal Resistance	Human Body Model.....2kV
QFN-16L 4x4, $\theta_{JA}$ .....40°C/W	Machine Model.....200V

## ELECTRICAL CHARACTERISTICS

Unless otherwise specified:  $V_{IN} = 2.85\text{V}$  to  $5.5\text{V}$ ,  $C1 = C2 = 1.0\mu\text{F}$  (ESR =  $0.03\Omega$ ,  $T_A = 25^\circ\text{C}$ )

PARAMETER	MIN	TYP	MAX	UNITS	CONDITIONS
Input Supply Voltage	2.5		5.5	V	
Under Voltage Lockout Threshold	1.8	2.2	2.4	V	$V_{IN}$ Rising
Under Voltage Lockout Hysteresis		50		mV	
Current into LEDs 1, 2, 3, and 4	18.5	20	21.5	mA	$R_{SET} = 24.0\text{k}\Omega$
	4.5	5	5.5	mA	$R_{SET} = 91.0\text{k}\Omega$
	2		20	mA	$2.7\text{V} < V_{IN} < 5.5\text{V}$
	2		30	mA	$3.1\text{V} < V_{IN} < 5.5\text{V}$
Quiescent Current		3	4	mA	$F_{OSC} = 1\text{MHz}$ , $I_{OUT} = 0\text{mA}$
Quiescent Current in Shutdown		1	10	$\mu\text{A}$	$V_{IN} = 4.5\text{V}$ , $E_n$ Pin = ZeroV
$I_{LED}$ Accuracy (Note 1)		2	7.5	%	$2\text{mA} < I_{LED} < 30\text{mA}$
Current Matching (Note 2)		1	5	%	$2\text{mA} < I_{LED} < 30\text{mA}$
1x mode to 1.5x mode Transition Voltage ( $V_{IN}$ Falling)		3.75	TBD	V	$V_{LED} = 3.5\text{V}$ , $I_{OUT} = 80\text{mA}$ $I_{LED1} = I_{LED2} = I_{LED3} = I_{LED4} = 20\text{mA}$
1.5x mode to 2x mode Transition Voltage ( $V_{IN}$ Falling)		2.65	2.8	V	$V_{LED} = 3.5\text{V}$ , $I_{OUT} = 80\text{mA}$ $I_{LED1} = I_{LED2} = I_{LED3} = I_{LED4} = 20\text{mA}$
Oscillator Frequency	0.8	1.0	1.2	MHz	
Input Current Limit	250	400	650	mA	Short Circuit applied from $V_{OUT}$ to GND
Output Over Voltage Protection		5.5	6	V	Open circuit at any LED that is programmed to be in the ON state

## ELECTRICAL CHARACTERISTICS

Unless otherwise specified:  $V_{IN} = 2.85V$  to  $5.5V$ ,  $C1 = C2 = 1.0\mu F$  (ESR =  $0.03\Omega$ ,  $T_A = 25^\circ C$ )

PARAMETER	MIN	TYP	MAX	UNITS	CONDITIONS
Input High Threshold	1.5			V	Input High Logic threshold (EN, CTRL0, CTRL1, CTRL2)
Input Low Threshold			0.4	V	Input Low Logic threshold (EN, CTRL0, CTRL1, CTRL2)
Input High Current			1	$\mu A$	$V_{IH} = V_{IN}$
Input Low Current			1	$\mu A$	$V_{IL} = GND$
Thermal Shutdown Threshold	140	150	180	$^\circ C$	
Thermal Shutdown Hysteresis		10		$^\circ C$	

Note 1:  $I_{LED(ERR)} = \left| \frac{I_{LED(MEA)} - I_{LED(SET)}}{I_{LED(SET)}} \right| \times 100\%$

Note 2: Current Matching refers to the difference in current from one LED to the next.

$$(I_{LED} \text{ Current Matching} \left| \frac{I_{LED(MAX)} - I_{LED(MIN)}}{I_{LED(MAX)} + I_{LED(MIN)}} \right| \times 100\%)$$

## FUNCTIONAL DIAGRAM

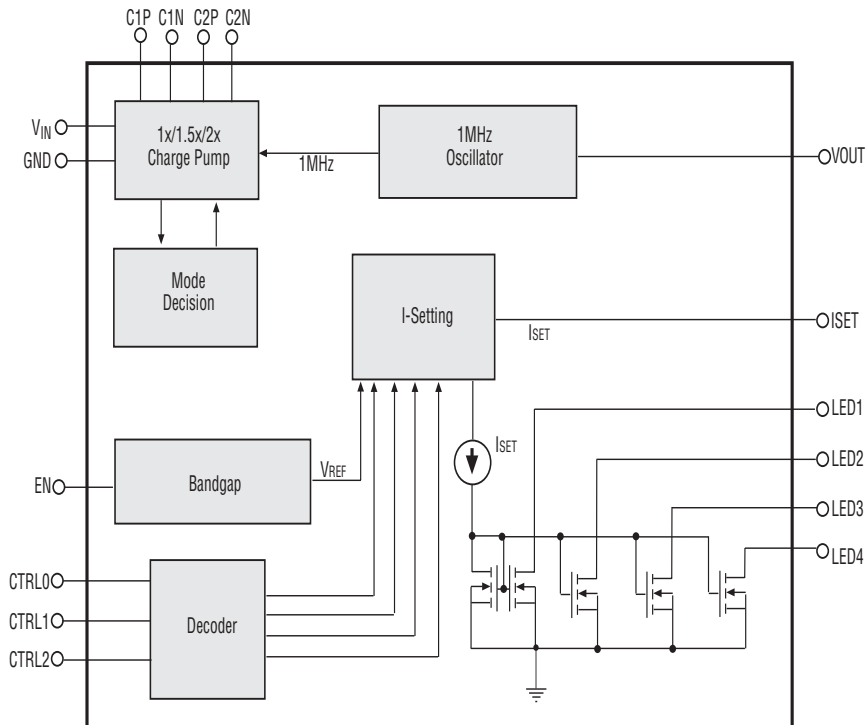

PIN #	PIN NAME	DESCRIPTION
1	EN	Chip Enable (Active High)
2	CTRL0	Output Control Bit 0 (See table 1)
3	CTRL1	Output Control Bit 1 (See table 1)
4	CTRL2	Output Control Bit 2 (See table 1)
5	$I_{SET}$	LED current is set by the value of the resistor $R_{SET}$ connected from the $I_{SET}$ pin to ground. Do not short the $I_{SET}$ pin. Voltage for $I_{SET}$ is typically 1.1V.
6	$V_{OUT}$	Output Voltage Source for connection to the LED anodes.
7	$V_{IN}$	Power Input Voltage
8	C1P	Positive Terminal of Bucket Capacitor 1
9	C1N	Negative Terminal of Bucket Capacitor 1
10	C2N	Negative Terminal of Bucket Capacitor 2
11	C2P	Positive Terminal of Bucket Capacitor 2
12	GND	Ground
13 to 16	LED1 to 4	Current Sink for LED. (If not in use, pin may be left open, grounded, or connected to $V_{IN}$ )
Exposed Pad	GND	Exposed pad should be soldered to PCB board and connected to GND

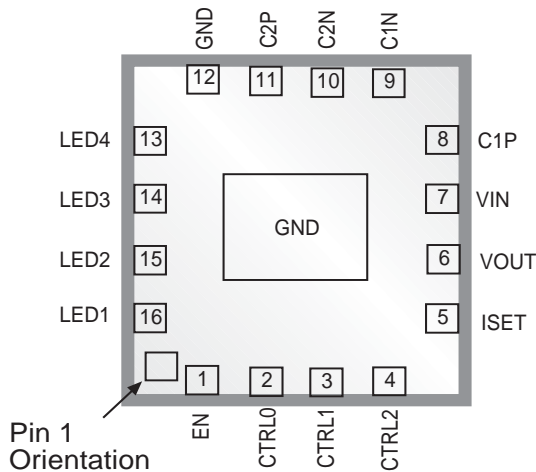

TOP VIEW

The SP6687 is a high efficiency charge pump white LED driver. It provides 4 channels of low drop-out voltage current source to regulate the current for 4 white LEDs. For high efficiency, the SP6687 implements 3 modes of charge pump: x1/x1.5/x2 modes. An external  $R_{SET}$  is used to set the current level of the White LEDs. SP6687 has an input current regulation circuit to reduce the input ripple.

### Soft Start

The SP6687 includes a soft start circuit to limit the inrush current at power on and mode switching. The soft start circuit holds the input current level long enough for output capacitor  $C_{OUT}$  to reach a desired voltage level. When the soft start turns off, the SP6687 will not sink current spiking from  $V_{IN}$ .

### Mode Decision

The SP6687 uses a smart mode decision method to select the working mode for maximum efficiency. The mode decision circuit senses the output and LED voltage for up/down selection.

### Dimming Control

CTRL0, CTRL1 and CTRL2 are used to control the on/off of correlated White LEDs. When an external PWM signal is connected to the control pin, the brightness of the white LEDs is adjusted by the duty cycle.

### LED Current Setting

The current flowing through White LEDs connected to the SP6687 can be set by  $R_{SET}$ . Every current that flows through each respective White LED is 440 times greater than the current of  $R_{SET}$ . The white LED current can be estimated by following equation:

where  $V_{ISET} = 1.1V$ , and  $R_{SET}$  is the resistance connected from  $I_{SET}$  to GND.

$$I_{LED} = 440 \times \left( \frac{V_{ISET}}{R_{SET}} \right)$$

### Thermal Shutdown

The SP6687 provides a high current capability to drive 4 white LEDs. A thermal shutdown circuit is needed to protect the chip from thermal damage. When the chip reaches the shutdown temperature of 150°C, the thermal shutdown circuit turns off the chip to prevent thermal accumulation in the chip.

### Overvoltage Protection

SP6687 regulates the output voltage by controlling the input current. When the output voltage reaches the designated level, SP6687 reduces the input current. Subsequently, the output voltage regulation also serves as an overvoltage protection circuit.

### Short Circuit Protection

A current limiting circuit is also included in the SP6687 for short circuit protection. Whenever the output sources a dangerously high current, the current limiting circuit takes over the output regulation circuit and reduces the output current to an acceptable level.

## APPLICATION INFORMATION

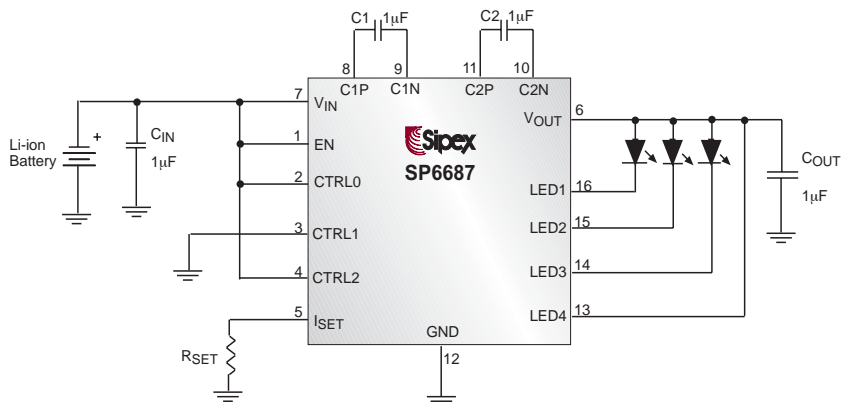

Typical Application Circuit For 3-White LEDs

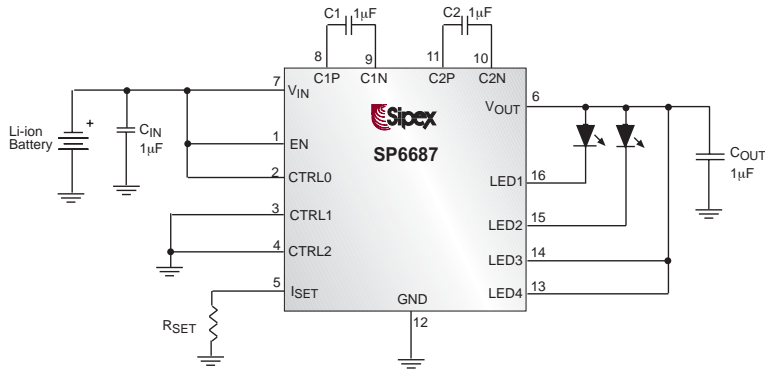

Typical Application Circuit for 2-White LEDs

Control Inputs			Output Status			
CTRL2	CTRL1	CTRL0	LED4	LED3	LED2	LED1
0	0	0	OFF	OFF	OFF	ON
0	0	1	OFF	OFF	ON	OFF
0	1	0	OFF	ON	OFF	OFF
0	1	1	ON	OFF	OFF	OFF
1	0	0	OFF	OFF	ON	ON
1	0	1	OFF	ON	ON	ON
1	1	0	ON	ON	ON	ON
1	1	1	OFF	OFF	OFF	OFF

Table 1. Typical application circuit for PWM dimming using a DC voltage into I<sub>SET</sub>.

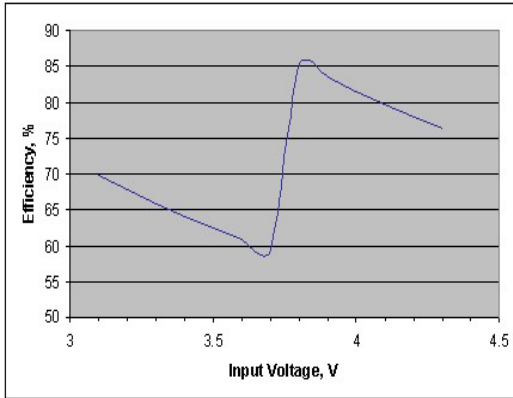

Figure 9: SP6687 Efficiency vs. Input voltage at I<sub>LED</sub> = 60mA, V<sub>F</sub> = 3.3V (falling voltage)

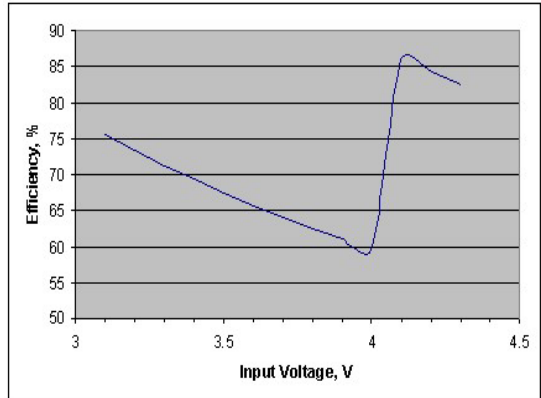

Figure 10: SP6687 Efficiency vs. Input voltage at I<sub>LED</sub> = 60mA, V<sub>F</sub> = 3.6V (falling voltage)

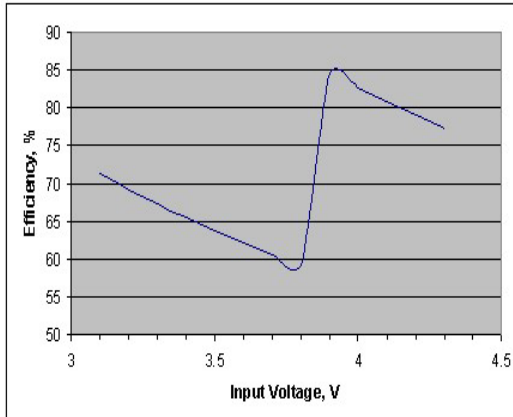

Figure 11: SP6687 Efficiency vs. Input voltage at I<sub>LED</sub> = 80mA, V<sub>F</sub> = 3.3V (falling voltage)

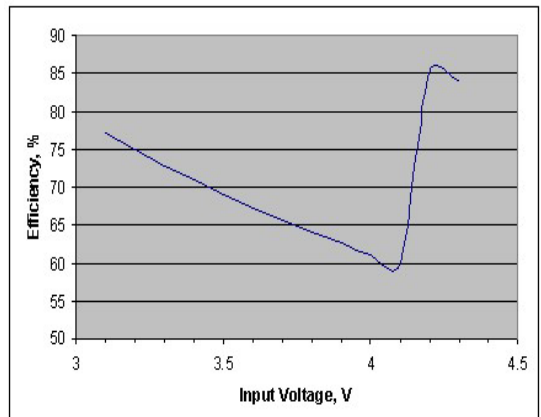

Figure 12: SP6687 Efficiency vs. Input voltage at I<sub>LED</sub> = 80mA, V<sub>F</sub> = 3.6V (falling voltage)

### Selecting Capacitors

To get better performance from the SP6687, the selection of appropriate capacitors is very important. These capacitors determine some parameters such as input and output ripple, power efficiency, maximum supply current by the charge pump and startup time. To reduce the input and output ripple effectively, low ESR ceramic capacitors are recommended.

To reduce output ripple, increasing the output capacitance  $C_{OUT}$  is generally necessary. However, this will increase the startup time of the output voltage.

For LED driver applications, the input voltage ripple is more important than output ripple. Input ripple is controlled by the input capacitor  $C_{IN}$  -- increasing the value of input capacitance can further reduce the ripple. Practically, the input voltage ripple depends on the impedance of the power supply. If a single input capacitor  $C_{IN}$  cannot satisfy the requirement of the application, it is necessary to add a low-pass filter. Figure 1 shows a C-R-C filter used on the SP6687. The input ripple can be reduced to less than 30mVp-p when driving 80mA of output current.

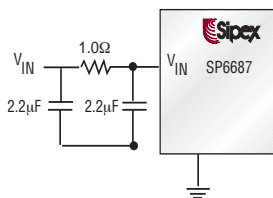

Figure 1. C-R-C filter used to reduce input ripple.

The flying capacitors  $C_1$  and  $C_2$  determine the supply current capability of the charge pump and influence the overall efficiency of the system. Lower values will improve efficiency, but will limit the current to the LEDs at low input voltages. For 4 X 20mA load over the entire input range of 2.7 to 5.5V, a capacitor of 1μF is optimal.

### Setting the LED Current

The SP6687 can be set to a fixed LED current by a resistor  $R_{SET}$  connected from  $I_{SET}$  to GND.  $R_{SET}$  establishes the reference current and mirrors the current into LED1, LED2, LED3, and LED4. The current into each LED is about 440 times the current that flows through  $R_{SET}$ . The approximate setting formula is given as follows:

$$I_{LED} = \frac{484(V)}{R_{SET}(\Omega)}$$

Figure 2 shows the typical value of  $R_{SET}$  versus average LED current and Table 2 shows the values of  $R_{SET}$  for a fixed LED current.

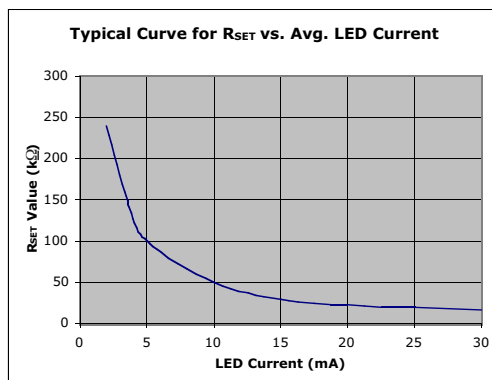

Figure 2. The typical curve of  $R_{SET}$  vs. LEDs average current.

$I_{LED}$ (mA)	$R_{SET}$ (kΩ)	Nearest Standard Value for RSET (kΩ)
5	91.0	91.0
10	47.9	47.5
15	32.7	32.4
20	24.0	24.0
25	19.6	19.6
30	16.4	16.5

Table 2.  $R_{SET}$  Value Selection

If maximum accuracy is required, a precision resistor is needed. The following equation shows how to calculate the error: 
$$I_{LED(ERR)} = \frac{|I_{LED(MEAS)} - I_{LED(SET)}|}{I_{LED(SET)}} \times 100\%$$

Where  $I_{LED(MEAS)}$  is practical measured LED current and  $I_{LED(SET)}$  is the LED current which is determined by  $R_{SET}$ .



LED Current Setting with NMOS

LED current setting control can also be achieved by using an external NMOS transistor to change the equivalent resistor of the I<sub>SET</sub> pin. Figure 3 illustrates this application circuit which has 3 bit signals and can set 8 different levels of LED current. Table 3 shows the relation between the equivalent resistor of the I<sub>SET</sub> pin and the respective control signal.

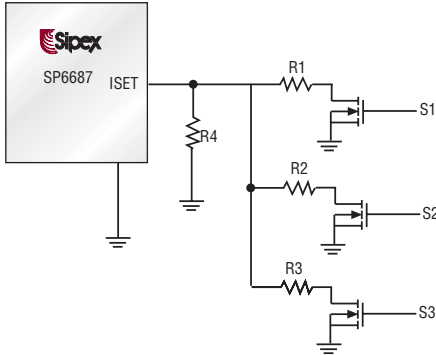

Figure 3. Typical application circuit for setting LED current using an NMOS transistor to set R<sub>SET</sub>

S1	S2	S3	Equivalent Resistor of I <sub>SET</sub> pin (R <sub>SET</sub> )
0	0	0	R <sub>SET</sub> =R <sub>4</sub>
0	0	1	R <sub>SET</sub> =R <sub>3</sub> //R <sub>4</sub>
0	1	0	R <sub>SET</sub> =R <sub>2</sub> //R <sub>4</sub>
0	1	1	R <sub>SET</sub> =R <sub>2</sub> //R <sub>3</sub> //R <sub>4</sub>
1	0	0	R <sub>SET</sub> =R <sub>1</sub> //R <sub>4</sub>
1	0	1	R <sub>SET</sub> =R <sub>1</sub> //R <sub>3</sub> //R <sub>4</sub>
1	1	0	R <sub>SET</sub> =R <sub>1</sub> //R <sub>2</sub> //R <sub>4</sub>
1	1	1	R <sub>SET</sub> =R <sub>1</sub> //R <sub>2</sub> //R <sub>3</sub> //R <sub>4</sub>

Table 3. Control signal and equivalent resistor of the I<sub>SET</sub> pin.

LED Dimming Control Methods

The SP6687 uses two methods to achieve LED dimming control. These methods are detailed below.

PWM Dimming

The first dimming method utilizes a PWM control signal into CTRL0, CTRL1, and CTRL2. Table 1 shows the relation between CTRLx and the 4 LED current states. For example, when CTRL1 and CTRL2 are at logic high and CTRL0 receives a PWM signal then 4 LEDs will be dimmed simultaneously. The average LED current can be derived by using a known PWM signal value. When the PWM signal logic is low the current can be set at a fixed value with the R<sub>SET</sub> resistor. The following equation will give the approximate value of the LED current:

$$I_{LED(AVG)} = \frac{T_{OFF} \times I_{LED(ON)}}{T_{PWM}}$$

Where T<sub>PWM</sub> is the period of the PWM dimming signal. T<sub>OFF</sub> is the time of the PWM signal at low. I<sub>LED(ON)</sub> is LED ON state current.

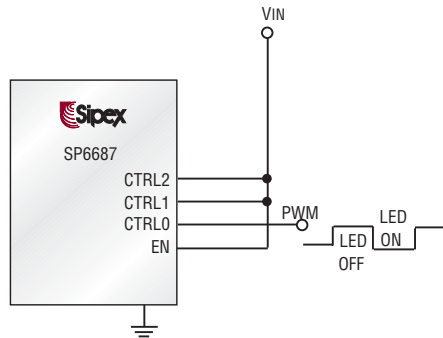

Figure 4. Typical application circuit for PWM dimming when driving 4 LEDs.

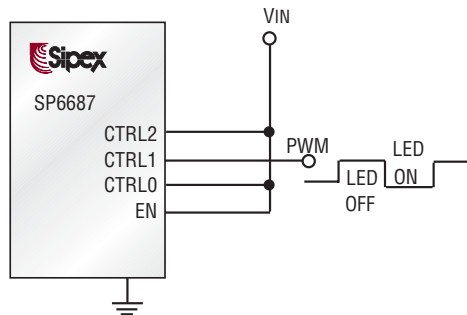

Figure 5. Typical application circuit for PWM dimming when driving 3 LEDs.

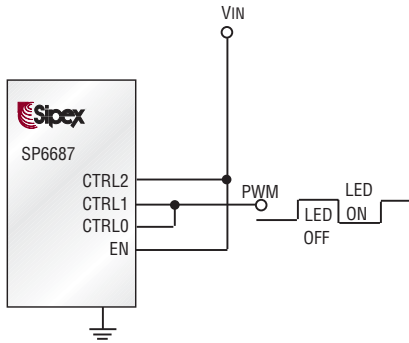

Figure 6. Typical application circuit for PWM dimming when driving 2 LEDs.

Due to the 100µs delay time between mode transfers, the duty cycle of the dimming frequency should not exceed the maximum duty cycle on the CTRLx pins. For best performance it is recommended to keep the dimming frequency between 200Hz and 1kHz. When the duty cycle is exceeded, the SP6687 cannot transfer modes properly. The following equation shows the relation between maximum duty of the CTRLx pins and the PWM dimming frequency:

$$D_{MAX} = (1 - 100 \times 10^{-6} \times F_D)$$

Where  $D_{MAX}$  is the Maximum Duty of CTRLX and  $F_D$  is the PWM Dimming Frequency.

Dimming Frequency (Hz)	CTRLX Maximum Duty	I <sub>LED</sub> Minimum Duty
1K	0.90	0.10
900	0.91	0.09
800	0.92	0.08
700	0.93	0.07
600	0.94	0.06
500	0.95	0.05
400	0.96	0.04
300	0.97	0.03
200	0.98	0.02

Table 4. Dimming frequency relative to Min/Max duty.

**Dimming using a DC voltage added to I<sub>SET</sub>**

Using an analog input voltage  $V_{ADJ}$  via a resistor  $R_{ADJ}$  that connects to the I<sub>SET</sub> pin is another method for dimming control of LEDs. Figure 7 shows the application circuit. For this application the LED current can be derived from the following equation:

$$I_{LED} = 440 \times [1.1 \times (1/R_{SET} + 1/R_{ADJ}) - V_{ADJ}/R_{ADJ}]$$

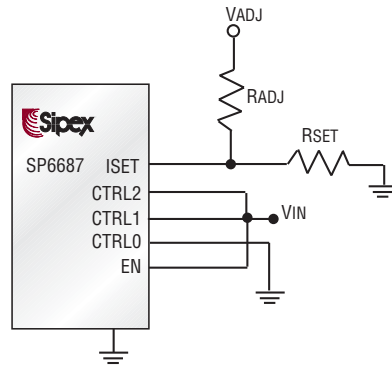

Figure 7. Typical application circuit for PWM dimming using a DC voltage into I<sub>SET</sub>.

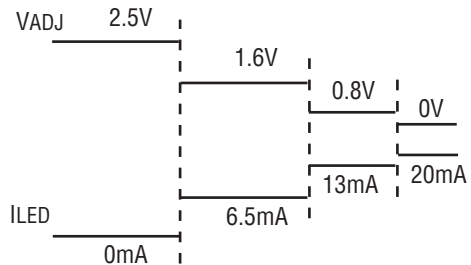
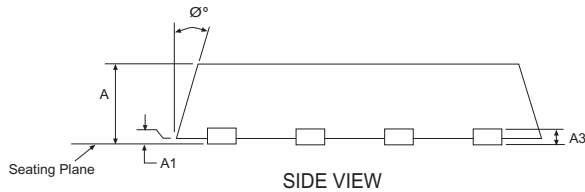
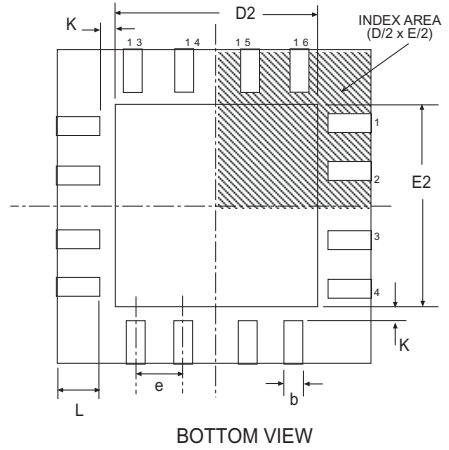
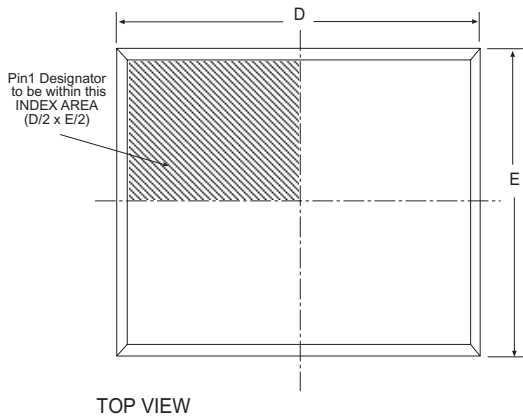

Figure 8. SP6687 dimming control application using a DC voltage into I<sub>SET</sub>.

Figure 8 shows the relation between  $V_{ADJ}$  and  $I_{LED}$  of a typical application example, with  $V_{ADJ}$  from 0 to 2.5V,  $R_{SET} = 43k\Omega$  and  $R_{ADJ} = 55k\Omega$ .



4x4 16 Pin QFN			JEDEC MO-220			Variation VGGC-4		
SYMBOL	Millimeters Controlling Dimension			Inches Conversion Factor: 1 Inch = 25.40 mm				
	MIN	NOM	MAX	MIN	NOM	MAX		
A	0.80	0.90	1.00	0.031	0.035	0.039		
A1	0.00	0.02	0.05	0.000	0.001	0.002		
A3	0.20 REF			0.008 REF				
K	0.20	-	-	0.008	-	-		
∅	0°	-	14°	0°	-	14°		
b	0.25	0.30	0.35	0.010	0.012	0.014		
D	4.00 BSC			0.157 BSC				
D2	2.20	2.40	2.60	0.087	0.094	0.102		
E	4.00 BSC			0.157 BSC				
E2	2.20	2.40	2.60	0.087	0.094	0.102		
e	0.65 BSC			0.026 BSC				
L	0.45	0.55	0.65	0.018	0.022	0.026		
SIPEX Pkg Signoff Date/Rev:				JL Oct31-05/Rev A				

---

## ORDERING INFORMATION

Part Number	Operating Temperature Range	Package Type
SP6687ER1-L/TR .....	-40°C to +85°C .....	16 Pin 4mmx4mm QFN

Available in lead-free packaging only.

-L = lead-free

/TR = Tape and Reel

Pack quantity is 3,000 for QFN.



ANALOG EXCELLENCE

**Sipex Corporation**

**Headquarters and  
Sales Office**

233 South Hillview Drive  
Milpitas, CA 95035  
TEL: (408) 934-7500  
FAX: (408) 935-7600

Sipex Corporation reserves the right to make changes to any products described herein. Sipex does not assume any liability arising out of the application or use of any product or circuit described herein; neither does it convey any license under its patent rights nor the rights of others.