



# FSUSB42 — Low-Power, Two-Port, High-Speed, USB2.0 (480Mbps) UART Switch

## Features

- Low On Capacitance: 3.7 pF Typical
- Low On Resistance: 3.9 Ω Typical
- Low Power Consumption: 1 μA Maximum
  - 15 μA Maximum I<sub>CC</sub>T over an Expanded Voltage Range (V<sub>IN</sub>=1.8 V, V<sub>CC</sub>=4.4 V)
- Wide -3 db Bandwidth: > 720 MHz
- Packaged in:
  - 10-Lead UMLP (1.4 x 1.8 mm)
  - 10-Lead MSOP
- 8 kV ESD Rating, >16 kV Power / GND ESD Rating
- Over-Voltage Tolerance (OVT) on all USB Ports Up to 5.25 V without External Components

## Applications

- Cell phone, PDA, Digital Camera, and Notebook
- LCD Monitor, TV, and Set-Top Box

## Description

The FSUSB42 is a bi-directional, low-power, two-port, high-speed, USB2.0 switch. Configured as a double-pole, double-throw switch (DPDT) switch, it is optimized for switching between any combination of high-speed (480 Mbps) or Full-Speed (12 Mbps) sources.

The FSUSB42 is compatible with the requirements of USB2.0 and features an extremely low on capacitance (C<sub>ON</sub>) of 3.7 pF. The wide bandwidth of this device (720 MHz) exceeds the bandwidth needed to pass the third harmonic, resulting in signals with minimum edge and phase distortion. Superior channel-to-channel crosstalk also minimizes interference.

The FSUSB42 contains special circuitry on the switch I/O pins for applications where the V<sub>CC</sub> supply is powered-off (V<sub>CC</sub>=0 V), which allows the device to withstand an over-voltage condition. This device is designed to minimize current consumption even when the control voltage applied to the SEL pin is lower than the supply voltage (V<sub>CC</sub>). This feature is especially valuable to ultra-portable applications, such as cell phones, allowing for direct interface with the general-purpose I/Os of the baseband processor. Other applications include switching and connector sharing in portable cell phones, PDAs, digital cameras, printers, and notebook computers.

## Ordering Information

Part Number	Top Mark	Operating Temperature Range	Package
FSUSB42UMX	HE	-40 to +85°C	10-Lead, Quad, Ultrathin Molded Leadless Package (UMLP), 1.4 x 1.8 mm
FSUSB42MUX	FSUSB42	-40 to +85°C	10-Lead, Molded Small-Outline Package (MSOP) JEDEC MO-187, 3.0 mm Wide

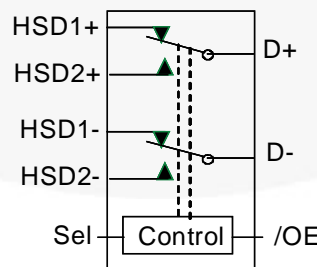


Figure 1. Analog Symbol

## Pin Assignments

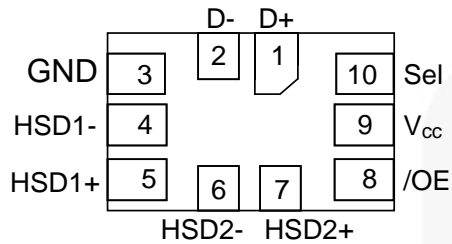


Figure 2. 10-Lead UMLP (Top-Through View)

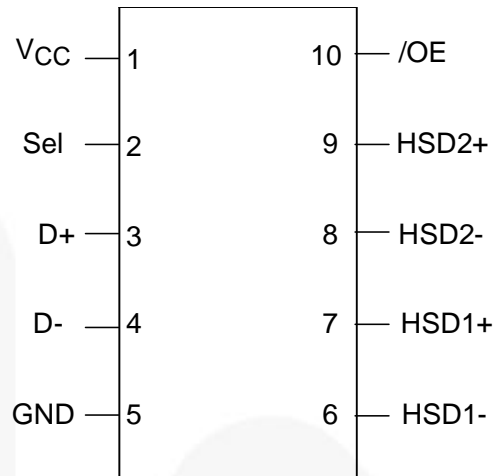


Figure 3. 10-Lead MSOP (Top-Through View)

## Pin Definitions

UMLP Pin#	MSOP Pin#	Name	Description
1	3	D+	Common USB Data Bus
2	4	D-	Common USB Data Bus
3	5	GND	Ground
4	6	HSD1-	Multiplexed Source Input 1
5	7	HSD1+	Multiplexed Source Input 1
6	8	HSD2-	Multiplexed Source Input 2
7	9	HSD2+	Multiplexed Source Input 2
8	10	/OE	Switch Enable
9	1	V <sub>cc</sub>	Supply Voltage
10	2	Sel	Switch Select

## Truth Table

SEL	/OE	Function
X	HIGH	Disconnect
LOW	LOW	D+= HSD1+, D-= HSD1-
HIGH	LOW	D+= HSD2+, D-= HSD2-

### Notes:

1.  $LOW \leq V_{IL}$ .
2.  $HIGH \geq V_{IH}$ .
3. X=Don't Care.

## Absolute Maximum Ratings

Stresses exceeding the absolute maximum ratings may damage the device. The device may not function or be operable above the recommended operating conditions and stressing the parts to these levels is not recommended. In addition, extended exposure to stresses above the recommended operating conditions may affect device reliability. The absolute maximum ratings are stress ratings only.

Symbol	Parameter	Min.	Max.	Unit
V <sub>CC</sub>	Supply Voltage	-0.5	5.6	V
V <sub>CNTRL</sub>	DC Input Voltage (S, /OE) <sup>(4)</sup>	-0.5	V <sub>CC</sub>	V
V <sub>SW</sub>	DC Switch I/O Voltage <sup>(4)</sup> (V <sub>CC</sub> =0V)	-0.50	5.25	V
I <sub>IK</sub>	DC Input Diode Current	-50		mA
I <sub>OUT</sub>	DC Output Current		100	mA
T <sub>STG</sub>	Storage Temperature	-65	+150	°C
MSL	Moisture Sensitivity Level (JEDEC J-STD-020A)		1	Level
ESD	Human Body Model, JEDEC: JESD22-A114	All Pins	7	kV
		I/O to GND	8	
		Power to GND	16	
	IEC 61000-4-2 System on USB Connector Pins D+ & D-	D+/D-	9	
		Air Discharge	15	
		Contact	8	
Charged Device Model, JEDEC: JESD22-C101	2			

**Note:**

4. The input and output negative ratings may be exceeded if the input and output diode current ratings are observed.

## Recommended Operating Conditions

The Recommended Operating Conditions table defines the conditions for actual device operation. Recommended operating conditions are specified to ensure optimal performance to the datasheet specifications. Fairchild does not recommend exceeding them or designing to Absolute Maximum Ratings.

Symbol	Parameter	Min.	Max.	Unit
V <sub>CC</sub>	Supply Voltage	2.4	4.4	V
V <sub>CNTRL</sub>	Control Input Voltage (S, /OE) <sup>(5)</sup>	0	V <sub>CC</sub>	V
V <sub>SW</sub>	Switch I/O Voltage	-0.5	4.5	V
T <sub>A</sub>	Operating Temperature	-40	+85	°C

**Note:**

5. The control input must be held HIGH or LOW and it must not float.

## DC Electrical Characteristics

All typical value are at  $T_A=25^\circ\text{C}$  unless otherwise specified.

Symbol	Parameter	Condition	$V_{CC}$ (V)	$T_A=-40^\circ\text{C}$ to $+85^\circ\text{C}$			Unit
				Min.	Typ.	Max.	
$V_{IK}$	Clamp Diode Voltage	$I_{IN}=-18\text{mA}$	3.0			-1.2	V
$V_{IH}$	Input Voltage High		2.4 to 3.6	1.3			V
			4.3	1.7			
$V_{IL}$	Input Voltage Low		2.4 to 3.6			0.5	V
			4.3			0.7	
$I_{IN}$	Control Input Leakage	$V_{SW}=0$ to $V_{CC}$	0 to 4.3	-1		1	$\mu\text{A}$
$I_{OZ}$	Off State Leakage	$0 \leq D_n, \text{HSD1n}, \text{HSD2n} \leq 3.6\text{ V}$	4.3	-2		2	$\mu\text{A}$
$I_{OFF}$	Power-Off Leakage Current (All I/O Ports)	$V_{SW}=0\text{ V}$ to $4.3\text{ V}$ , $V_{CC}=0\text{ V}$ Figure 5	0	-2		2	$\mu\text{A}$
$R_{ON}$	HS Switch On Resistance <sup>(6)</sup>	$V_{SW}=0.4\text{ V}$ , $I_{ON}=-8\text{ mA}$ Figure 4	2.4		4.5	7.5	$\Omega$
			3.0		3.9	6.5	
$\Delta R_{ON}$	HS Delta $R_{ON}$ <sup>(7)</sup>	$V_{SW}=0.4\text{ V}$ , $I_{ON}=-8\text{ mA}$	3.0		0.65		$\Omega$
$I_{CC}$	Quiescent Supply Current	$V_{CNTRL}=0$ or $V_{CC}$ , $I_{OUT}=0$	4.3			1	$\mu\text{A}$
$I_{CCT}$	Increase in $I_{CC}$ Current per Control Voltage and $V_{CC}$	$V_{CNTRL}=2.6\text{ V}$ , $V_{CC}=4.3\text{ V}$	4.3			10	$\mu\text{A}$
		$V_{CNTRL}=1.8\text{ V}$ , $V_{CC}=4.3\text{ V}$	4.3			15	$\mu\text{A}$

### Notes:

6. Measured by the voltage drop between HSDn and Dn pins at the indicated current through the switch. On resistance is determined by the lower of the voltage on the two (HSDn or Dn ports).
7. Guaranteed by characterization.

## AC Electrical Characteristics

All typical value are for  $V_{CC}=3.3\text{ V}$  at  $T_A=25^\circ\text{C}$  unless otherwise specified.

Symbol	Parameter	Condition	$V_{CC}$ (V)	$T_A=-40^\circ\text{C to }+85^\circ\text{C}$			Unit
				Min.	Typ.	Max.	
$t_{ON}$	Turn-On Time S, /OE to Output	$R_L=50\ \Omega$ , $C_L=5\ \text{pF}$ , $V_{SW}=0.8\ \text{V}$ , Figure 6, Figure 7	2.4		24	40	ns
			3.0 to 3.6		13	30	
$t_{OFF}$	Turn-Off Time S, /OE to Output	$R_L=50\ \Omega$ , $C_L=5\ \text{pF}$ , $V_{SW}=0.8\ \text{V}$ , Figure 6, Figure 7	2.4		15	35	ns
			3.0 to 3.6		12	25	
$t_{PD}$	Propagation Delay <sup>8</sup>	$C_L=5\ \text{pF}$ , $R_L=50\ \Omega$ , Figure 6, Figure 8	3.3		0.25		ns
$t_{BBM}$	Break-Before-Make	$R_L=50\ \Omega$ , $C_L=5\ \text{pF}$ , $V_{SW1}=V_{SW2}=0.8\ \text{V}$ , Figure 10	2.4	2.0		10	ns
			3.0 to 3.6	2.0		6.5	
$O_{IRR}$	Off Isolation	$R_L=50\ \Omega$ , $f=240\ \text{MHz}$ , Figure 12	3.0 to 3.6		-30		dB
Xtalk	Non-Adjacent Channel Crosstalk	$R_L=50\ \Omega$ , $f=240\ \text{MHz}$ , Figure 13	3.0 to 3.6		-45		dB
BW	-3db Bandwidth	$R_L=50\ \Omega$ , $C_L=0\ \text{pF}$ , Figure 11	3.0 to 3.6		720		MHz
		$R_L=50\ \Omega$ , $C_L=5\ \text{pF}$ , Figure 11			550		MHz

**Note:**

8. Guaranteed by characterization.

## USB High-Speed-Related AC Electrical Characteristics

All typical value are for  $V_{CC}=3.3\text{ V}$  at  $T_A=25^\circ\text{C}$  unless otherwise specified.

Symbol	Parameter	Condition	$V_{CC}$ (V)	$T_A=-40^\circ\text{C to }+85^\circ\text{C}$			Unit
				Min.	Typ.	Max.	
$t_{SK(P)}$	Skew of Opposite Transitions of the Same Output <sup>(9)</sup>	$C_L=5\ \text{pF}$ , $R_L=50\ \Omega$ , Figure 9			20		ps
$t_J$	Total Jitter <sup>(9)</sup>	$R_L=50\ \Omega$ , $C_L=5\ \text{pF}$ , $t_R=t_F=500\ \text{ps}$ (10-90%) at 480 Mbps (PRBS= $2^{15}-1$ )			200		ps

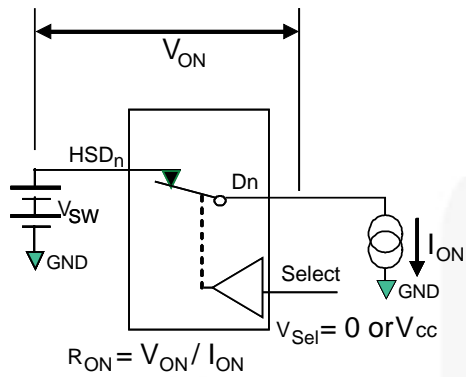
**Note:**

9. Guaranteed by characterization.

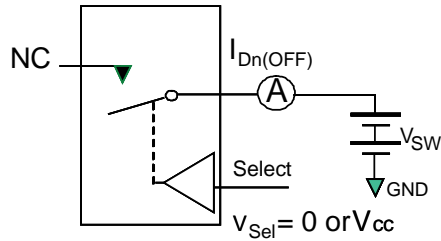
## Capacitance

Symbol	Parameter	Condition	$T_A=-40^\circ\text{C to }+85^\circ\text{C}$			Unit
			Min.	Typ.	Max.	
$C_{IN}$	Control Pin Input Capacitance	$V_{CC}=0\ \text{V}$		1.5		pF
$C_{ON}$	D+/D- On Capacitance	$V_{CC}=3.3\ \text{V}$ , /OE=0 V, $f=240\ \text{MHz}$ , Figure 15		3.7		
$C_{OFF}$	D1n, D2n Off Capacitance	$V_{CC}$ and /OE=3.3 V, Figure 14		2.0		

**Test Diagrams**

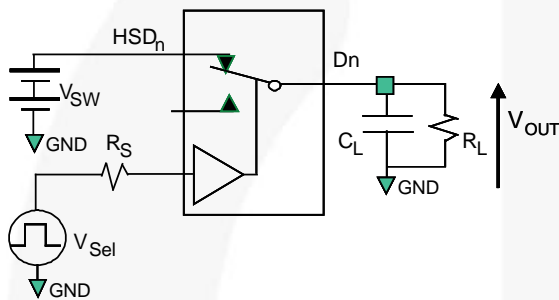


**Figure 4. On Resistance**



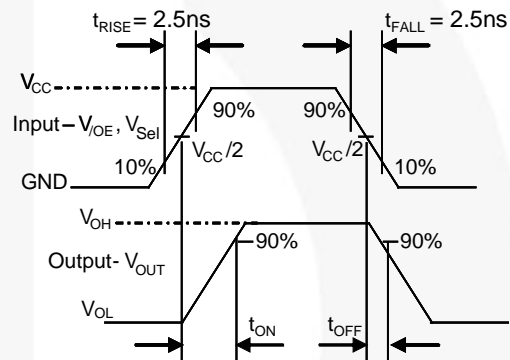
\*\*Each switch port is tested separately

**Figure 5. Off Leakage**

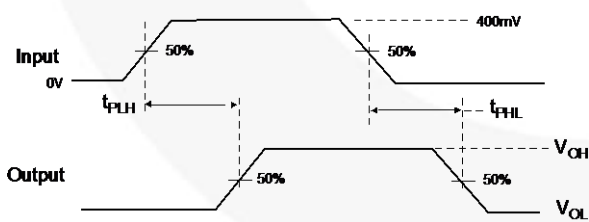


$R_L$ ,  $R_S$ , and  $C_L$  are functions of the application environment (see AC Tables for specific values)  
 $C_L$  includes test fixture and stray capacitance.

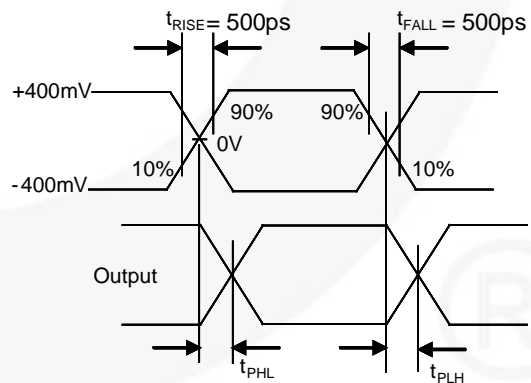
**Figure 6. AC Test Circuit Load**



**Figure 7. Turn-On / Turn-Off Waveforms**

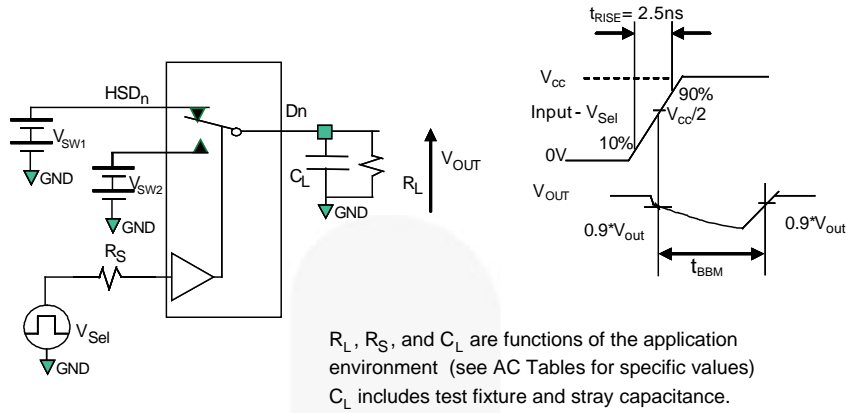


**Figure 8. Propagation Delay ( $t_{rtf} = 500$  ps)**

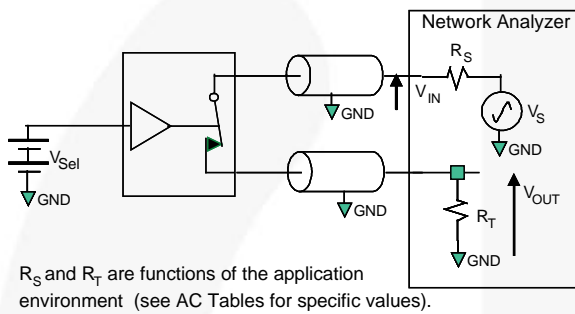


**Figure 9. Intra-Pair Skew Test  $t_{SK(P)}$**

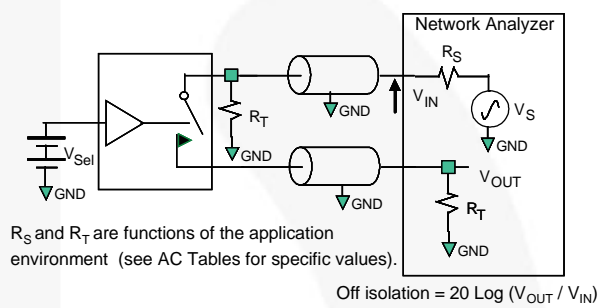
**Test Diagrams (Continued)**



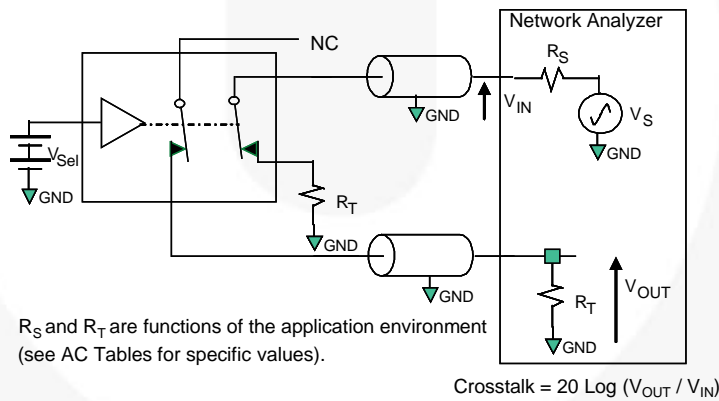
**Figure 10. Break-Before-Make Interval Timing**



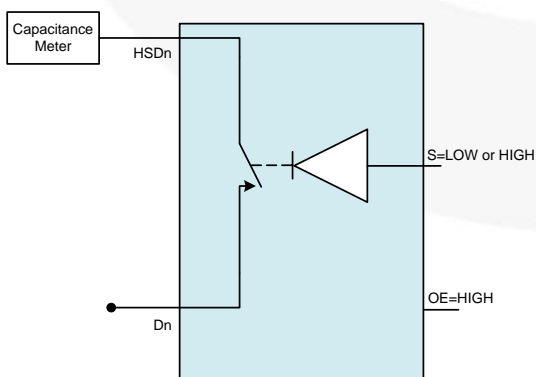
**Figure 11. Bandwidth**



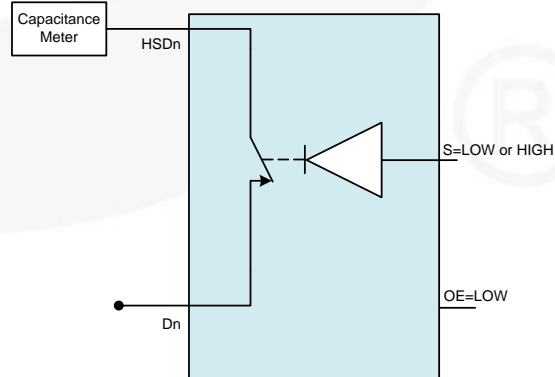
**Figure 12. Channel Off Isolation**



**Figure 13. Non-Adjacent Channel-to-Channel Crosstalk**



**Figure 14. Channel Off Capacitance**



**Figure 15. Channel On Capacitance**

### Physical Dimensions

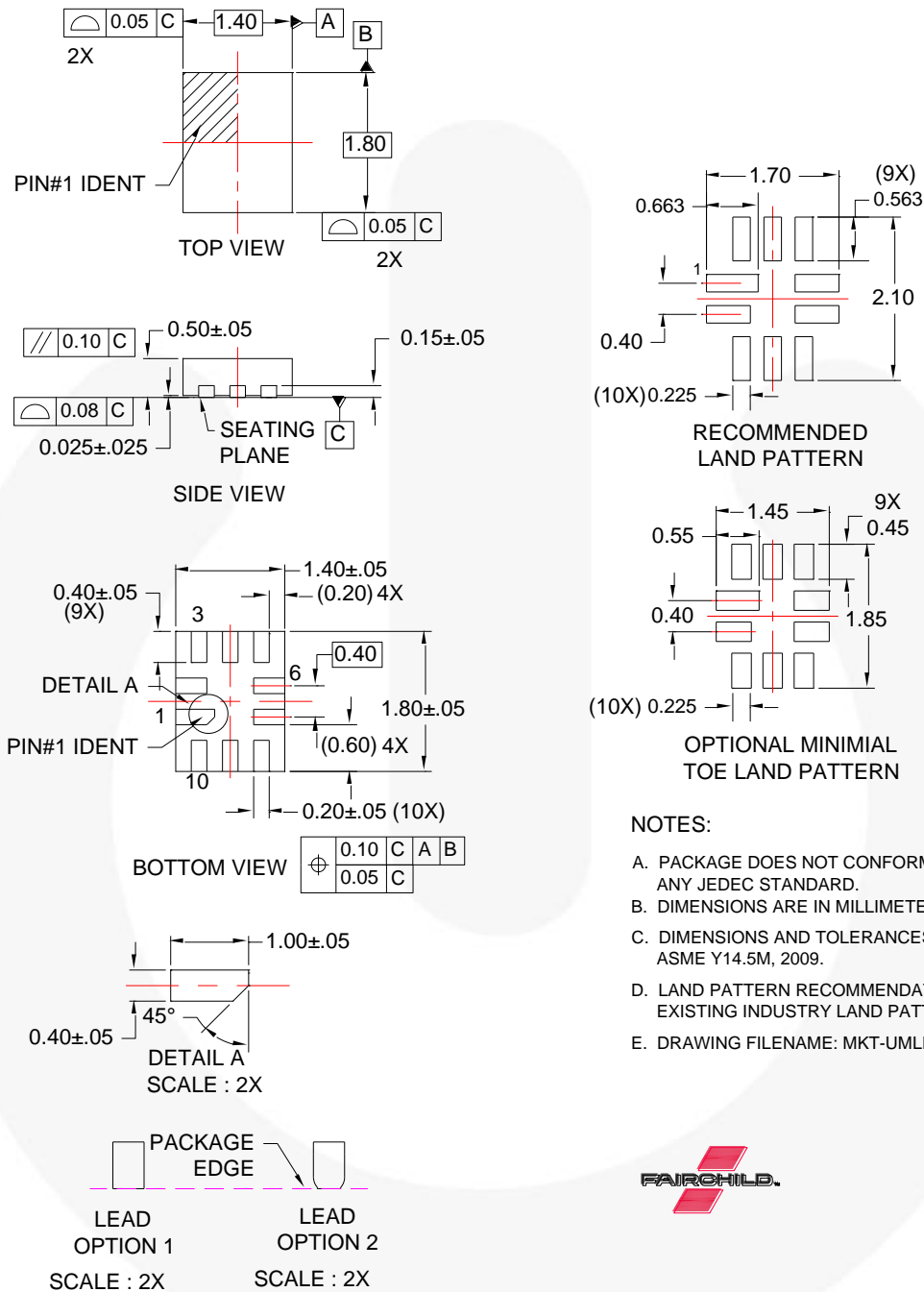


Figure 16. 10-Lead, Ultrathin Molded Leadless Package (UMLP)



Physical Dimensions (Continued)

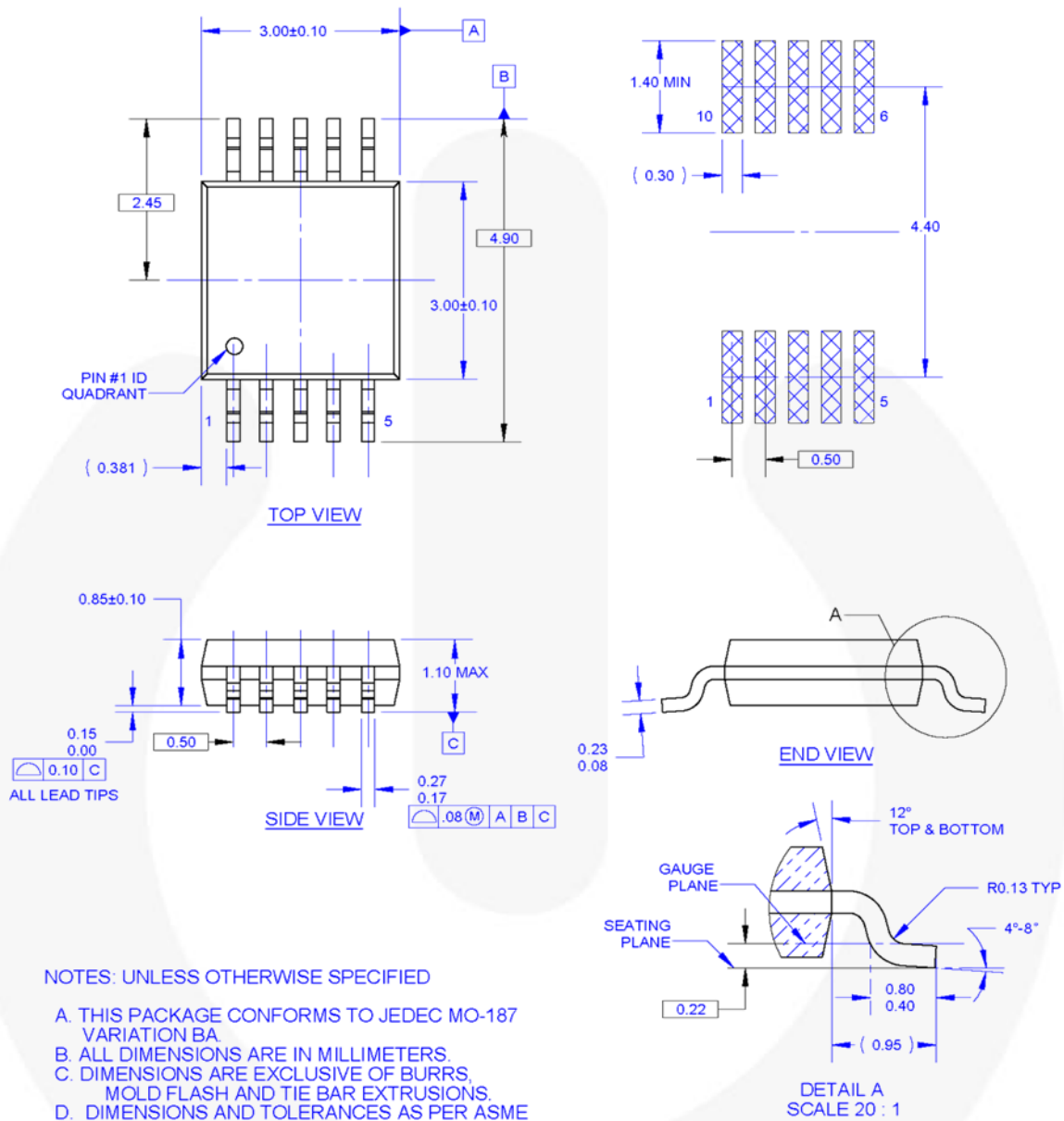


Figure 17. 10-Lead, Molded Small Outline Package (MSOP)



**TRADEMARKS**

The following includes registered and unregistered trademarks and service marks, owned by Fairchild Semiconductor and/or its global subsidiaries, and is not intended to be an exhaustive list of all such trademarks.

- |                          |  |                                    |                  |
|--------------------------|--|------------------------------------|------------------|
| AccuPower™               | F-PFS™   | OPTOPLANAR®                        | SYSTEM GENERAL®  |
| AttitudeEngine™          | FRFET®   | Power Supply WebDesigner™          | TinyBoost®       |
| Awinda®                  | Global Power Resource™ SM                      | PowerTrench®                       | TinyBuck®        |
| AX-CAP®*                 | GreenBridge™                                   | PowerXS™                           | TinyCalc™        |
| BitSiC™                  | Green FPS™                                     | Programmable Active Droop™         | TinyLogic®       |
| Build it Now™            | Green FPS™ e-Series™                           | QFET®                              | TINYOPTO™        |
| CorePLUS™                | Gmax™  | QS™                                | TinyPower™       |
| CorePOWER™               | GTO™   | Quiet Series™                      | TinyPWM™         |
| CROSSVOL7™               | IntelliMAX™                                    | RapidConfigure™                    | TranSiC™         |
| CTL™                     | ISOPLANAR™                                     | Saving our world, 1mW/W at a time™ | TriFault Detect™ |
| Current Transfer Logic™  | Making Small Speakers Sound Louder and Better™ | SignalWise™                        | TRUECURRENT®*    |
| DEUXPEED®                | MegaBuck™                                      | SmartMax™                          | µSerDes™         |
| Dual Cool™               | MICROCOUPLER™                                  | SMART START™                       | SerDes™          |
| EcoSPARK®                | MicroFET™                                      | Solutions for Your Success™        | UHC®             |
| EfficientMax™            | MicroPak™                                      | SPM®                               | Ultra FRFET™     |
| ESBC™                    | MicroPak2™                                     | STEALTH™                           | UniFET™          |
| Fairchild®               | MillerDrive™                                   | SuperFET®                          | VCX™             |
| Fairchild Semiconductor® | MotionMax™                                     | SuperSOT™-3                        | VisualMax™       |
| FACT Quiet Series™       | MotionGrid®                                    | SuperSOT™-6                        | VoltagePlus™     |
| FACT®                    | MTI®   | SuperSOT™-8                        | XS™              |
| FAST®                    | MTX®   | SupreMOS®                          | Xsens™           |
| FastvCore™               | MVN®   | SyncFET™                           | 仙童™              |
| FETBench™                | mWSaver®                                       | Sync-Lock™                         |                  |
| FPS™                     | OptoHiT™                                       |                                    |                  |
|                          | OPTOLOGIC®                                     |                                    |                  |

\* Trademarks of System General Corporation, used under license by Fairchild Semiconductor.

**DISCLAIMER**

FAIRCHILD SEMICONDUCTOR RESERVES THE RIGHT TO MAKE CHANGES WITHOUT FURTHER NOTICE TO ANY PRODUCTS HEREIN TO IMPROVE RELIABILITY, FUNCTION, OR DESIGN. TO OBTAIN THE LATEST, MOST UP-TO-DATE DATASHEET AND PRODUCT INFORMATION, VISIT OUR WEBSITE AT [HTTP://WWW.FAIRCHILDSEMI.COM](http://www.fairchildsemi.com). FAIRCHILD DOES NOT ASSUME ANY LIABILITY ARISING OUT OF THE APPLICATION OR USE OF ANY PRODUCT OR CIRCUIT DESCRIBED HEREIN; NEITHER DOES IT CONVEY ANY LICENSE UNDER ITS PATENT RIGHTS, NOR THE RIGHTS OF OTHERS. THESE SPECIFICATIONS DO NOT EXPAND THE TERMS OF FAIRCHILD'S WORLDWIDE TERMS AND CONDITIONS, SPECIFICALLY THE WARRANTY THEREIN, WHICH COVERS THESE PRODUCTS.

**AUTHORIZED USE**

Unless otherwise specified in this data sheet, this product is a standard commercial product and is not intended for use in applications that require extraordinary levels of quality and reliability. This product may not be used in the following applications, unless specifically approved in writing by a Fairchild officer: (1) automotive or other transportation, (2) military/aerospace, (3) any safety critical application – including life critical medical equipment – where the failure of the Fairchild product reasonably would be expected to result in personal injury, death or property damage. Customer's use of this product is subject to agreement of this Authorized Use policy. In the event of an unauthorized use of Fairchild's product, Fairchild accepts no liability in the event of product failure. In other respects, this product shall be subject to Fairchild's Worldwide Terms and Conditions of Sale, unless a separate agreement has been signed by both Parties.

**ANTI-COUNTERFEITING POLICY**

Fairchild Semiconductor Corporation's Anti-Counterfeiting Policy. Fairchild's Anti-Counterfeiting Policy is also stated on our external website, [www.fairchildsemi.com](http://www.fairchildsemi.com), under Terms of Use

Counterfeiting of semiconductor parts is a growing problem in the industry. All manufacturers of semiconductor products are experiencing counterfeiting of their parts. Customers who inadvertently purchase counterfeit parts experience many problems such as loss of brand reputation, substandard performance, failed applications, and increased cost of production and manufacturing delays. Fairchild is taking strong measures to protect ourselves and our customers from the proliferation of counterfeit parts. Fairchild strongly encourages customers to purchase Fairchild parts either directly from Fairchild or from Authorized Fairchild Distributors who are listed by country on our web page cited above. Products customers buy either from Fairchild directly or from Authorized Fairchild Distributors are genuine parts, have full traceability, meet Fairchild's quality standards for handling and storage and provide access to Fairchild's full range of up-to-date technical and product information. Fairchild and our Authorized Distributors will stand behind all warranties and will appropriately address any warranty issues that may arise. Fairchild will not provide any warranty coverage or other assistance for parts bought from Unauthorized Sources. Fairchild is committed to combat this global problem and encourage our customers to do their part in stopping this practice by buying direct or from authorized distributors.

**PRODUCT STATUS DEFINITIONS**

**Definition of Terms**

Datasheet Identification	Product Status	Definition
Advance Information	Formative / In Design	Datasheet contains the design specifications for product development. Specifications may change in any manner without notice.
Preliminary	First Production	Datasheet contains preliminary data; supplementary data will be published at a later date. Fairchild Semiconductor reserves the right to make changes at any time without notice to improve design.
No Identification Needed	Full Production	Datasheet contains final specifications. Fairchild Semiconductor reserves the right to make changes at any time without notice to improve the design.
Obsolete	Not In Production	Datasheet contains specifications on a product that is discontinued by Fairchild Semiconductor. The datasheet is for reference information only.

Rev. 175