

April 1995

50A, 400V - 600V Ultrafast Diodes

Features

- Ultrafast with Soft Recovery <65ns
- Operating Temperature +175°C
- Reverse Voltage Up To 600V
- Avalanche Energy Rated
- Planar Construction

Applications

- Switching Power Supplies
- Power Switching Circuits
- General Purpose

Description

RURU5040, RURU5050 and RURU5060 (TA9909) are ultrafast diodes with soft recovery characteristics ($t_{RR} < 65ns$). They have low forward voltage drop and are silicon nitride passivated ion-implanted epitaxial planar construction.

These devices are intended for use as freewheeling/clamping diodes and rectifiers in a variety of switching power supplies and other power switching applications. Their low stored charge and ultrafast recovery with soft recovery characteristic minimizes ringing and electrical noise in many power switching circuits reducing power loss in the switching transistors.

PACKAGING AVAILABILITY

PART NUMBER	PACKAGE	BRAND
RURU5040	TO-218	RURU5040
RURU5050	TO-218	RURU5050
RURU5060	TO-218	RURU5060

NOTE: When ordering, use the entire part number.

Package

JEDEC STYLE SINGLE LEAD TO-218

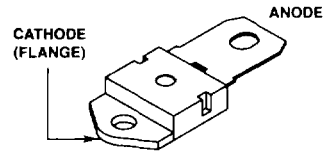

Symbol



Absolute Maximum Ratings $T_C = +25^\circ C$, Unless Otherwise Specified

	RURU5040	RURU5050	RURU5060	UNITS
Peak Repetitive Reverse Voltage V_{RRM}	400	500	600	V
Working Peak Reverse Voltage V_{RWM}	400	500	600	V
DC Blocking Voltage V_R	400	500	600	V
Average Rectified Forward Current $I_{F(AV)}$ ($T_C = +102^\circ C$)	50	50	50	A
Repetitive Peak Surge Current I_{FSM} (Square Wave, 20kHz)	100	100	100	A
Nonrepetitive Peak Surge Current I_{FSM} (Halfwave, 1 Phase, 60Hz)	500	500	500	A
Maximum Power Dissipation P_D	150	150	150	W
Avalanche Energy E_{AVL}	40	40	40	mJ
Operating and Storage Temperature T_{STG}, T_J	-65 to +175	-65 to +175	-65 to +175	$^\circ C$

5
ULTRAFAST
SINGLE DIODES

Specifications RURU5040, RURU5050, RURU5060

Electrical Specifications $T_C = +25^\circ\text{C}$, Unless Otherwise Specified

SYMBOL	TEST CONDITION	LIMITS									UNITS
		RURU5040			RURU5050			RURU5060			
		MIN	TYP	MAX	MIN	TYP	MAX	MIN	TYP	MAX	
V_F	$I_F = 50\text{A}, T_C = +25^\circ\text{C}$	-	-	1.6	-	-	1.6	-	-	1.6	V
V_F	$I_F = 50\text{A}, T_C = +150^\circ\text{C}$	-	-	1.4	-	-	1.4	-	-	1.4	V
I_R	$V_R = 400\text{V}, T_C = +25^\circ\text{C}$	-	-	500	-	-	-	-	-	-	μA
	$V_R = 500\text{V}, T_C = +25^\circ\text{C}$	-	-	-	-	-	500	-	-	-	μA
	$V_R = 600\text{V}, T_C = +25^\circ\text{C}$	-	-	-	-	-	-	-	-	500	μA
I_R	$V_R = 400\text{V}, T_C = +150^\circ\text{C}$	-	-	1.5	-	-	-	-	-	-	mA
	$V_R = 500\text{V}, T_C = +150^\circ\text{C}$	-	-	-	-	-	1.5	-	-	-	mA
	$V_R = 600\text{V}, T_C = +150^\circ\text{C}$	-	-	-	-	-	-	-	-	1.5	mA
t_{RR}	$I_F = 1\text{A}, di_F/dt = 100\text{A}/\mu\text{s}$	-	-	65	-	-	65	-	-	65	ns
	$I_F = 50\text{A}, di_F/dt = 100\text{A}/\mu\text{s}$	-	-	75	-	-	75	-	-	75	ns
t_A	$I_F = 50\text{A}, di_F/dt = 100\text{A}/\mu\text{s}$	-	30	-	-	30	-	-	30	-	ns
t_B	$I_F = 50\text{A}, di_F/dt = 100\text{A}/\mu\text{s}$	-	20	-	-	20	-	-	20	-	ns
$R_{\theta JC}$		-	-	1	-	-	1	-	-	1	$^\circ\text{C}/\text{W}$

DEFINITIONS

V_F = Instantaneous forward voltage (pw = 300 μs , D = 2%).

I_R = Instantaneous reverse current.

t_{RR} = Reverse recovery time (See Figure 2), summation of $t_A + t_B$.

t_A = Time to reach peak reverse current (See Figure 2).

t_B = Time from peak I_{RM} to projected zero crossing of I_{RM} based on a straight line from peak I_{RM} through 25% of I_{RM} (See Figure 2).

$R_{\theta JC}$ = Thermal resistance junction to case.

E_{AVL} = Controlled avalanche energy (See Figures 7 and 8).

pw = pulse width.

D = duty cycle.

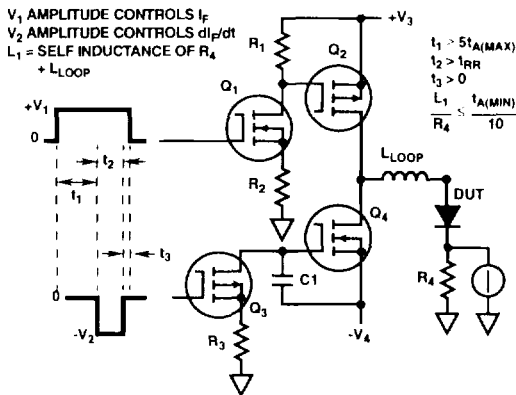

FIGURE 1. t_{RR} TEST CIRCUIT

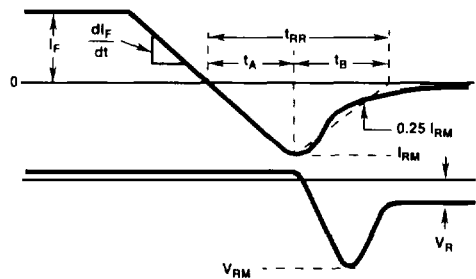

FIGURE 2. t_{RR} WAVEFORMS AND DEFINITIONS

Typical Performance Curves

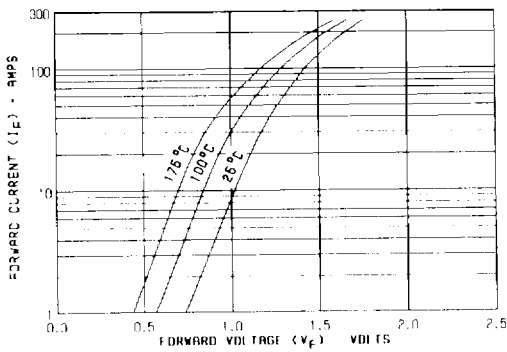

FIGURE 3. TYPICAL FORWARD CURRENT vs FORWARD VOLTAGE DROP

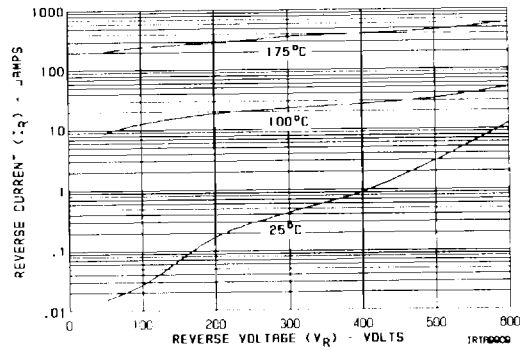

FIGURE 4. TYPICAL REVERSE CURRENT vs VOLTAGE

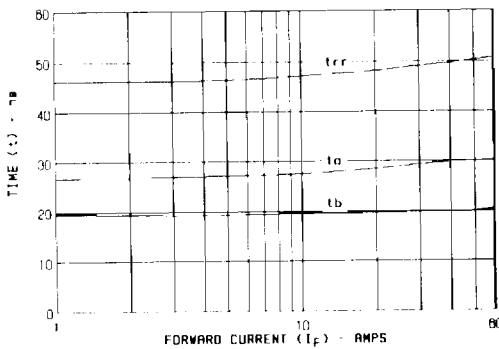

FIGURE 5. TYPICAL t_{RR} , t_A AND t_B CURVES vs FORWARD CURRENT

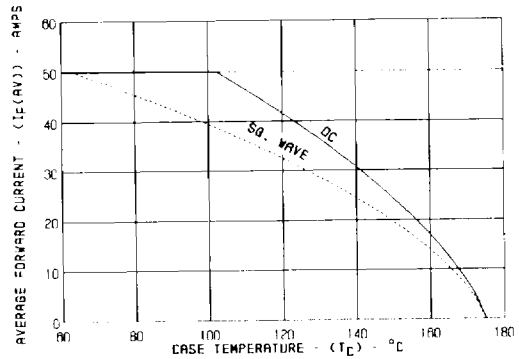

FIGURE 6. CURRENT DERATING CURVE FOR ALL TYPES

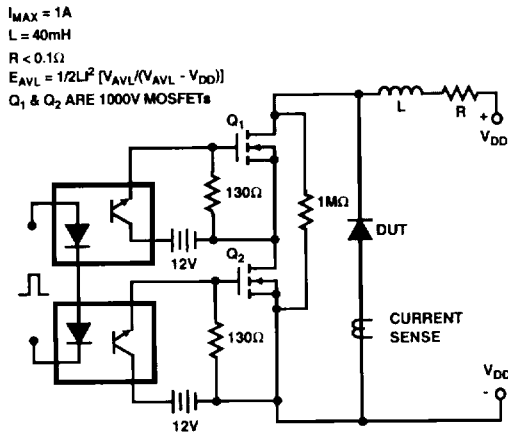

FIGURE 7. AVALANCHE ENERGY TEST CIRCUIT

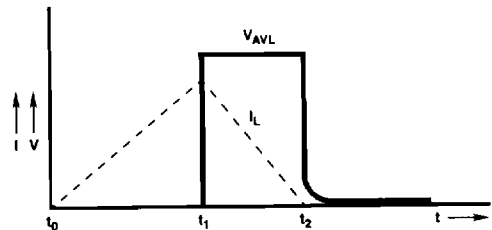

FIGURE 8. AVALANCHE CURRENT AND VOLTAGE WAVEFORMS