

Features

- High speed
 - $t_{AA} = 15 \text{ ns}$
- CMOS for optimum speed/power
- Automatic power down when deselected
- TTL-compatible inputs and outputs

Functional Description

The CY7C107BN is a high performance CMOS static RAMs organized as 1,048,576 words by 1 bit. Easy memory expansion is provided by an active LOW Chip Enable (CE) and tristate drivers. The device has an automatic power down feature that reduces power consumption by more than 65% when deselected.

Writing to the device is accomplished by taking Chip Enable (CE) and Write Enable (WE) inputs LOW. Data on the input pin (D_{IN}) is written into the memory location specified on the address pins (A_0 through A_{19}).

Reading from the device is accomplished by taking Chip Enable (CE) LOW while Write Enable (WE) remains HIGH. Under these conditions, the contents of the memory location specified by the address pins appear on the data output (D_{OUT}) pin.

The output pin (D_{OUT}) is placed in a high impedance state when the device is deselected (CE HIGH) or during a write operation (CE and WE LOW).

The CY7C107BN is available in a standard 400-mil-wide SOJ.

Logic Block Diagram

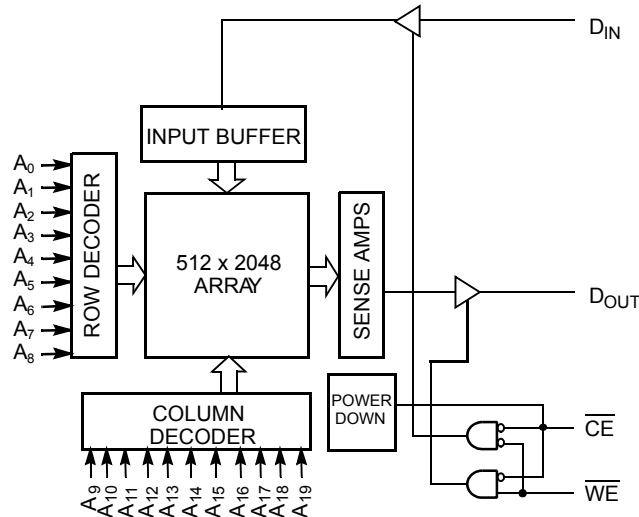

Pin Configuration

Figure 1. 28-Pin SOJ (Top View)

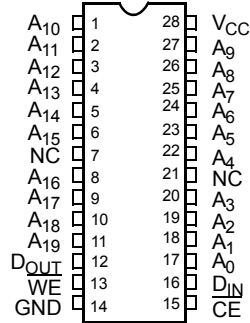

Selection Guide

Description	7C107BN-15
Maximum Access Time (ns)	15
Maximum Operating Current (mA)	80
Maximum CMOS Standby Current I_{SB2} (mA)	2

Maximum Ratings

Exceeding the maximum ratings may impair the useful life of the device. These user guidelines are not tested.

Storage Temperature -65°C to +150°C
 Ambient Temperature with Power Applied -55°C to +125°C
 Supply Voltage on V_{CC} Relative to GND^[1] -0.5V to +7.0V
 DC Voltage Applied to Outputs in High Z State^[1] -0.5V to $V_{CC} + 0.5V$

DC Input Voltage^[1] -0.5V to $V_{CC} + 0.5V$
 Current into Outputs (LOW) 20 mA
 Static Discharge Voltage >2001V (per MIL-STD-883, Method 3015)
 Latch Up Current >200 mA

Operating Range

Range	Ambient Temperature ^[2]	V_{CC}
Commercial	0°C to +70°C	5V ± 10%

Electrical Characteristics Over the Operating Range

Parameter	Description	Test Conditions	7C107BN-15		Unit
			Min	Max	
V_{OH}	Output HIGH Voltage	$V_{CC} = \text{Min}, I_{OH} = -4.0 \text{ mA}$	2.4		V
V_{OL}	Output LOW Voltage	$V_{CC} = \text{Min}, I_{OL} = 8.0 \text{ mA}$		0.4	V
V_{IH}	Input HIGH Voltage		2.2	$V_{CC} + 0.3$	V
V_{IL}	Input LOW Voltage ^[1]		-0.3	0.8	V
I_{IX}	Input Leakage Current	$GND \leq V_I \leq V_{CC}$	-1	+1	mA
I_{OZ}	Output Leakage Current	$GND \leq V_I \leq V_{CC}$, Output Disabled	-5	+5	mA
I_{OS}	Output Short Circuit Current ^[3]	$V_{CC} = \text{Max}, V_{OUT} = GND$		-300	mA
I_{CC}	V_{CC} Operating Supply Current	$V_{CC} = \text{Max}, I_{OUT} = 0 \text{ mA}, f = f_{MAX} = 1/t_{RC}$		80	mA
I_{SB1}	Automatic \overline{CE} Power Down Current—TTL Inputs	Max V_{CC} , $\overline{CE} \geq V_{IH}$, $V_{IN} \geq V_{IH}$ or $V_{IN} \leq V_{IL}$, $f = f_{MAX}$		20	mA
I_{SB2}	Automatic \overline{CE} Power Down Current—CMOS Inputs	Max V_{CC} , $\overline{CE} \geq V_{CC} - 0.3V$, $V_{IN} \geq V_{CC} - 0.3V$ or $V_{IN} \leq 0.3V$, $f = 0$		2	mA

Capacitance^[4]

Parameter	Description	Test Conditions	Max	Unit
C_{IN} : Addresses	Input Capacitance	$T_A = 25 \times C, f = 1 \text{ MHz}, V_{CC} = 5.0V$	7	pF
C_{IN} : Controls			10	pF
C_{OUT}	Output Capacitance		10	pF

Notes

- V_{IL} (min.) = -2.0V for pulse durations of less than 20 ns.
- T_A is the "Instant On" case temperature.
- Not more than 1 output should be shorted at one time. Duration of the short circuit should not exceed 30 seconds.
- Tested initially and after any design or process changes that may affect these parameters.

Figure 2. AC Test Loads and Waveforms

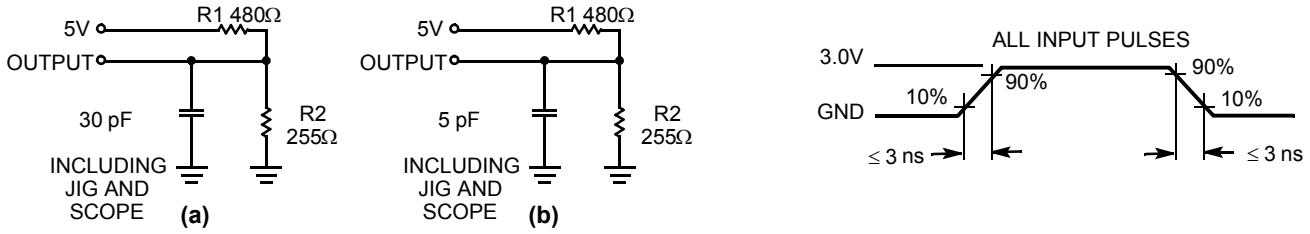

Equivalent to: THÉVENIN EQUIVALENT
 OUTPUT — 167Ω — 1.73V

Switching Characteristics^[5] Over the Operating Range

Parameter	Description	7C107BN-15		Unit
		Min	Max	
READ CYCLE				
t _{RC}	Read Cycle Time	15		ns
t _{AA}	Address to Data Valid		15	ns
t _{OHA}	Data Hold from Address Change	3		ns
t _{ACE}	CE LOW to Data Valid		15	ns
t _{LZCE}	CE LOW to Low Z ^[6]	3		ns
t _{HZCE}	CE HIGH to High Z ^[6, 7]		7	ns
t _{PU}	CE LOW to Power Up	0		ns
t _{PD}	CE HIGH to Power Down		15	ns
WRITE CYCLE^[8]				
t _{WC}	Write Cycle Time	15		ns
t _{SCE}	CE LOW to Write End	12		ns
t _{AW}	Address Setup to Write End	12		ns
t _{HA}	Address Hold from Write End	0		ns
t _{SA}	Address Setup to Write Start	0		ns
t _{PWE}	WE Pulse Width	12		ns
t _{SD}	Data Setup to Write End	8		ns
t _{HD}	Data Hold from Write End	0		ns
t _{LZWE}	WE HIGH to Low Z ^[6]	3		ns
t _{HZWE}	WE LOW to High Z ^[6, 7]		7	ns

Notes

5. Test conditions assume signal transition time of 3 ns or less, timing reference levels of 1.5V, input pulse levels of 0 to 3.0V, and output loading of the specified I_{OL}/I_{OH} and 30-pF load capacitance.
6. At any given temperature and voltage condition, t_{HZCE} is less than t_{LZCE} and t_{HZWE} is less than t_{LZWE} for any given device.
7. t_{HZCE} and t_{HZWE} are specified with a load capacitance of 5 pF as in part (b) of AC Test Loads. Transition is measured ±500 mV from steady-state voltage.
8. The internal write time of the memory is defined by the overlap of CE LOW and WE LOW. CE and WE must be LOW to initiate a write, and the transition of any of these signals can terminate the write. The input data setup and hold timing should be referenced to the leading edge of the signal that terminates the write.

Switching Waveforms

Figure 3. Read Cycle No. 1^[10, 11]

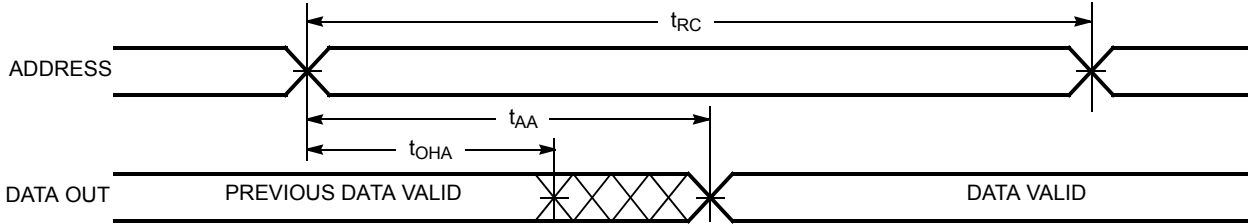

Figure 4. Read Cycle No. 2^[11, 12]

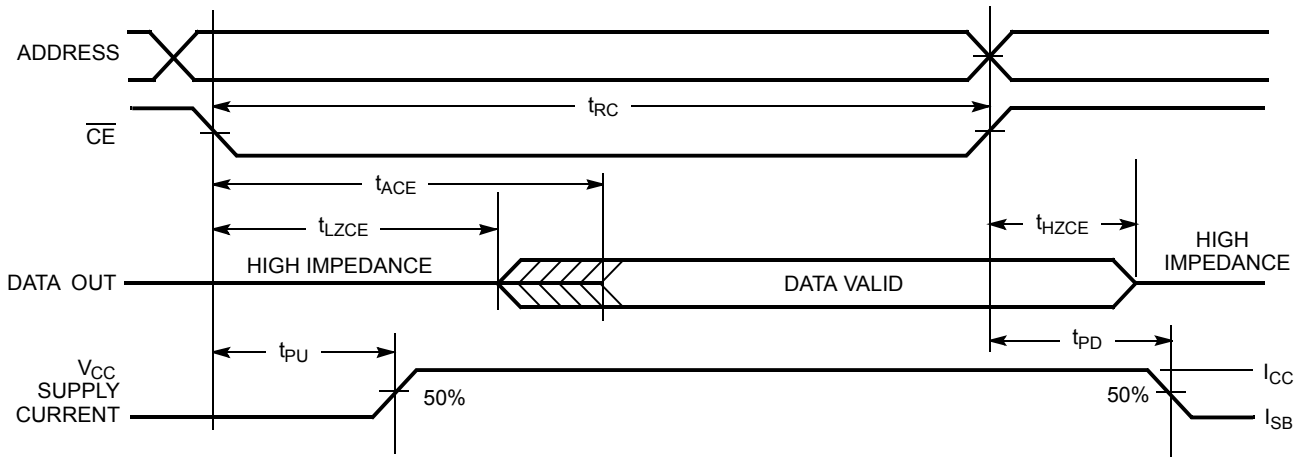
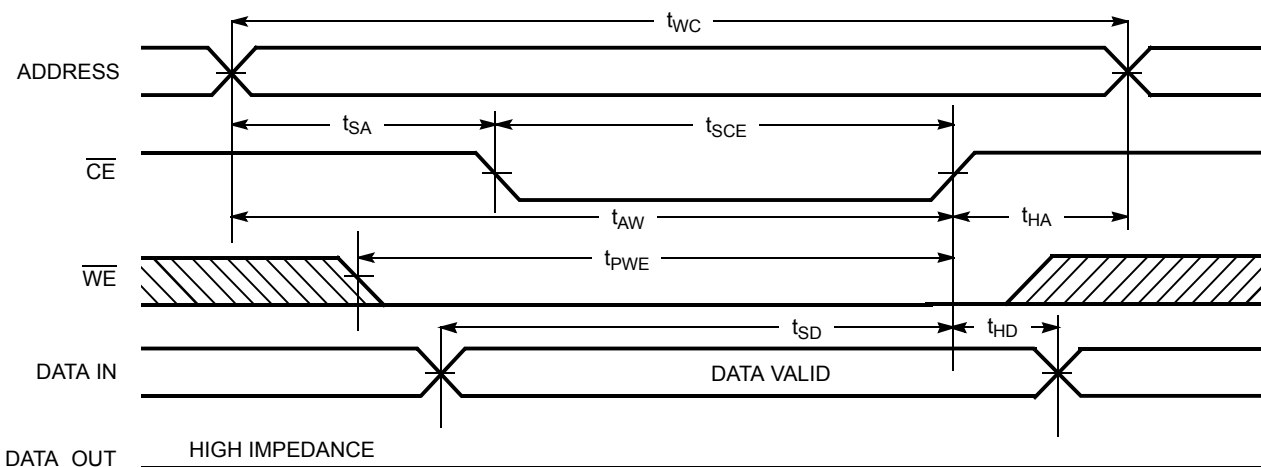

Figure 5. Write Cycle No. 1 (CE Controlled)^[13]



Notes

- 9. No input may exceed $V_{CC} + 0.5V$.
- 10. Device is continuously selected, $\overline{CE} = V_{IL}$.
- 11. \overline{WE} is HIGH for read cycle.
- 12. Address valid prior to or coincident with \overline{CE} transition LOW.
- 13. If \overline{CE} goes HIGH simultaneously with \overline{WE} going HIGH, the output remains in a high impedance state.

Switching Waveforms (continued)

Figure 6. Write Cycle No. 2 ($\overline{\text{WE}}$ Controlled)^[13]

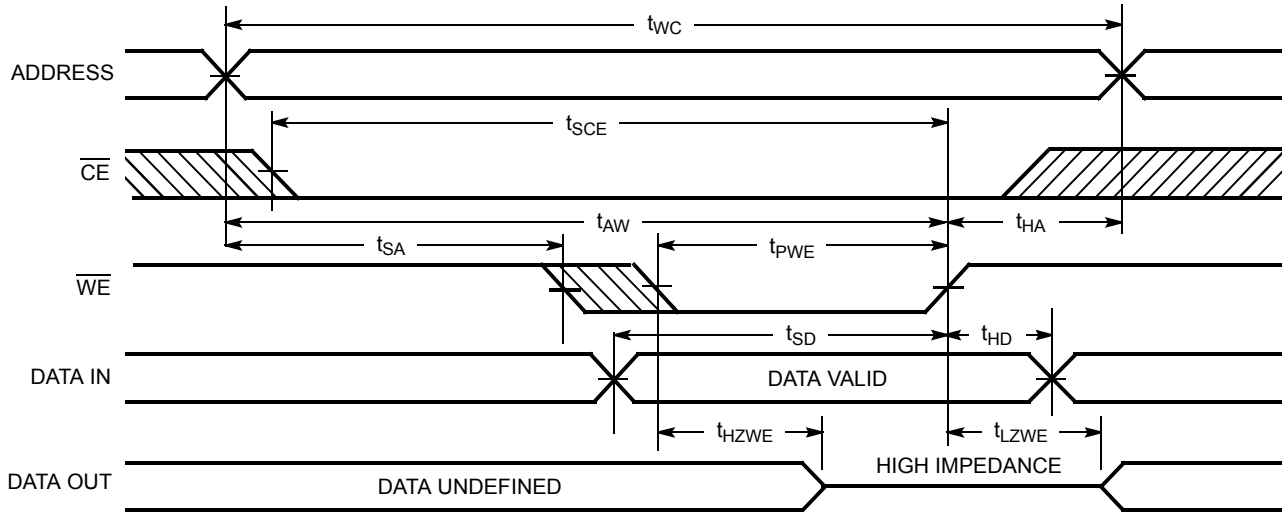

Truth Table

$\overline{\text{CE}}$	$\overline{\text{WE}}$	D _{OUT}	Mode	Power
H	X	High Z	Power Down	Standby (I _{SB})
L	H	Data Out	Read	Active (I _{CC})
L	L	High Z	Write	Active (I _{CC})

Ordering Information

Speed (ns)	Ordering Code	Package Diagram	Package Type	Operating Range
15	CY7C107BN-15VC	51-85032	28-Pin (400-Mil) Molded SOJ	Commercial

Contact your local sales representative regarding availability of these parts

Package Diagrams

Figure 7. 28-Pin (400 Mil) Molded SOJ (51-85032)

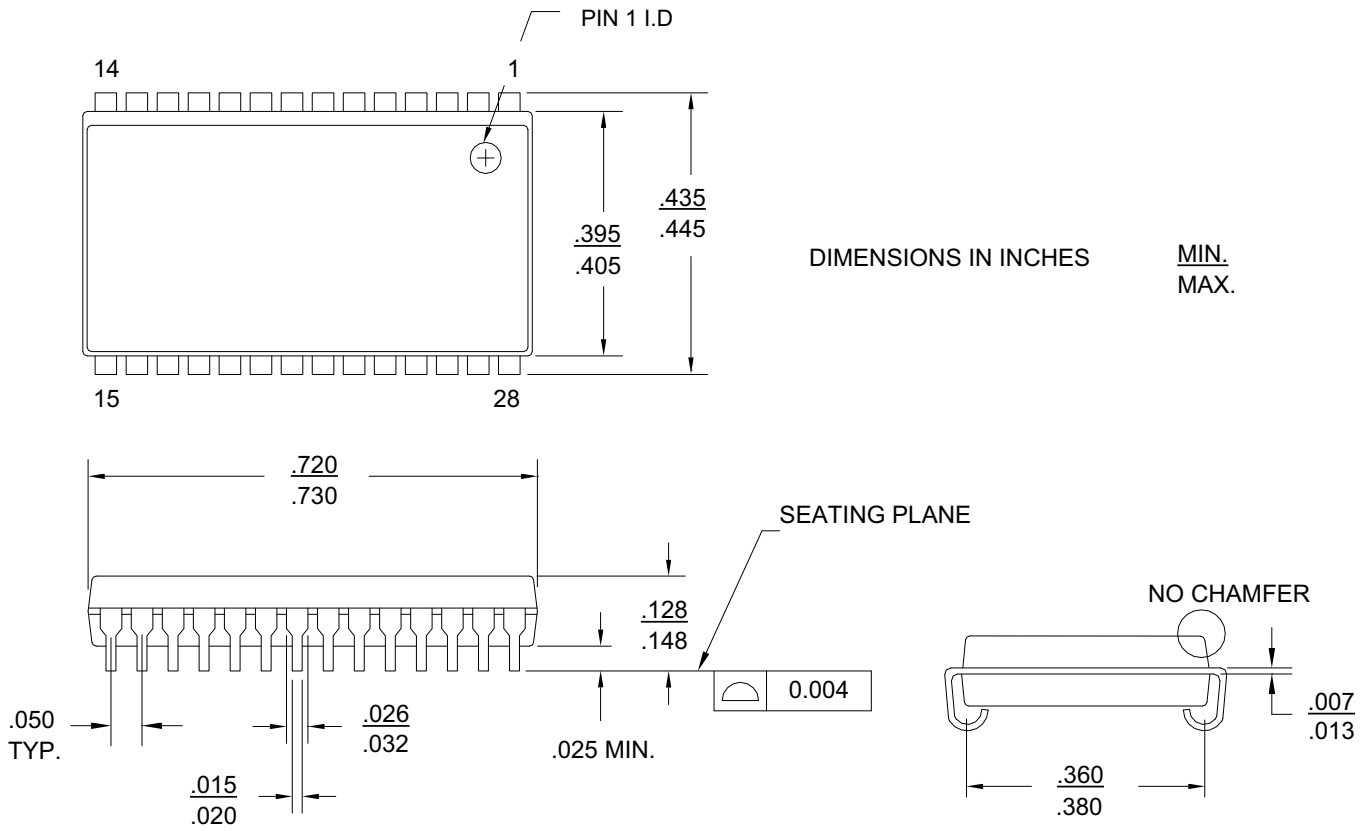

NOTES :

1. PACKAGE WEIGHT : 1.24g
2. JEDEC REFERENCE : MS-027

51-85032.*D

Document History Page

Document Title: CY7C107BN 1M x 1 Static RAM Document Number: 001-06426				
REV.	ECN NO.	Submission Date	Orig. of Change	Description of Change
**	423847	See ECN	NXR	New Data Sheet
*A	2891262	03/12/2010	VKN	Removed CY7C1007BN from the datasheet, Removed Industrial operating grade, Removed 28-Pin (300-Mil) Molded SOJ package, Updated 28-Pin (400-Mil) Molded SOJ POD Updated Ordering Information table Updated URLs in Sales, Solutions, and Legal Information

Sales, Solutions, and Legal Information

Worldwide Sales and Design Support

Cypress maintains a worldwide network of offices, solution centers, manufacturer’s representatives, and distributors. To find the office closest to you, visit us at [Cypress Locations](#).

Products

Automotive	cypress.com/go/automotive
Clocks & Buffers	cypress.com/go/clocks
Interface	cypress.com/go/interface
Lighting & Power Control	cypress.com/go/powerpsoc cypress.com/go/plc
Memory	cypress.com/go/memory
Optical & Image Sensing	cypress.com/go/image
PSoC	cypress.com/go/psoc
Touch Sensing	cypress.com/go/touch
USB Controllers	cypress.com/go/USB
Wireless/RF	cypress.com/go/wireless

PSoC Solutions

psoc.cypress.com/solutions
PSoC 1 | PSoC 3 | PSoC 5

© Cypress Semiconductor Corporation, 2006-2010. The information contained herein is subject to change without notice. Cypress Semiconductor Corporation assumes no responsibility for the use of any circuitry other than circuitry embodied in a Cypress product. Nor does it convey or imply any license under patent or other rights. Cypress products are not warranted nor intended to be used for medical, life support, critical control or safety applications, unless pursuant to an express written agreement with Cypress. Furthermore, Cypress does not authorize its products for use as critical components in life-support systems where a malfunction or failure may reasonably be expected to result in significant injury to the user. The inclusion of Cypress products in life-support systems application implies that the manufacturer assumes all risk of such use and in doing so indemnifies Cypress against all charges.

Any Source Code (software and/or firmware) is owned by Cypress Semiconductor Corporation (Cypress) and is protected by and subject to worldwide patent protection (United States and foreign), United States copyright laws and international treaty provisions. Cypress hereby grants to licensee a personal, non-exclusive, non-transferable license to copy, use, modify, create derivative works of, and compile the Cypress Source Code and derivative works for the sole purpose of creating custom software and or firmware in support of licensee product to be used only in conjunction with a Cypress integrated circuit as specified in the applicable agreement. Any reproduction, modification, translation, compilation, or representation of this Source Code except as specified above is prohibited without the express written permission of Cypress.

Disclaimer: CYPRESS MAKES NO WARRANTY OF ANY KIND, EXPRESS OR IMPLIED, WITH REGARD TO THIS MATERIAL, INCLUDING, BUT NOT LIMITED TO, THE IMPLIED WARRANTIES OF MERCHANTABILITY AND FITNESS FOR A PARTICULAR PURPOSE. Cypress reserves the right to make changes without further notice to the materials described herein. Cypress does not assume any liability arising out of the application or use of any product or circuit described herein. Cypress does not authorize its products for use as critical components in life-support systems where a malfunction or failure may reasonably be expected to result in significant injury to the user. The inclusion of Cypress’ product in a life-support systems application implies that the manufacturer assumes all risk of such use and in doing so indemnifies Cypress against all charges.

Use may be limited by and subject to the applicable Cypress software license agreement.