



Clock Synthesizer with Differential SRC and CPU Outputs

Features

- Supports Intel® Pentium® 4-type CPUs
- Selectable CPU frequencies
- 3.3V power supply
- Nine copies of PCI clocks
- Four copies of 3V66 with one optional VCH
- Two copies 48-MHz clock
- Three differential CPU clock pairs
- One differential SRC clock
- Support SMBus/I²C Byte, Word and Block Read/ Write
- Ideal Lexmark Spread Spectrum profile for maximum electromagnetic interference (EMI) reduction
- 48-pin SSOP package

CPU	SRC	3V66	PCI	REF	48M
x 3	x 1	x 4	x 9	x 2	x 2

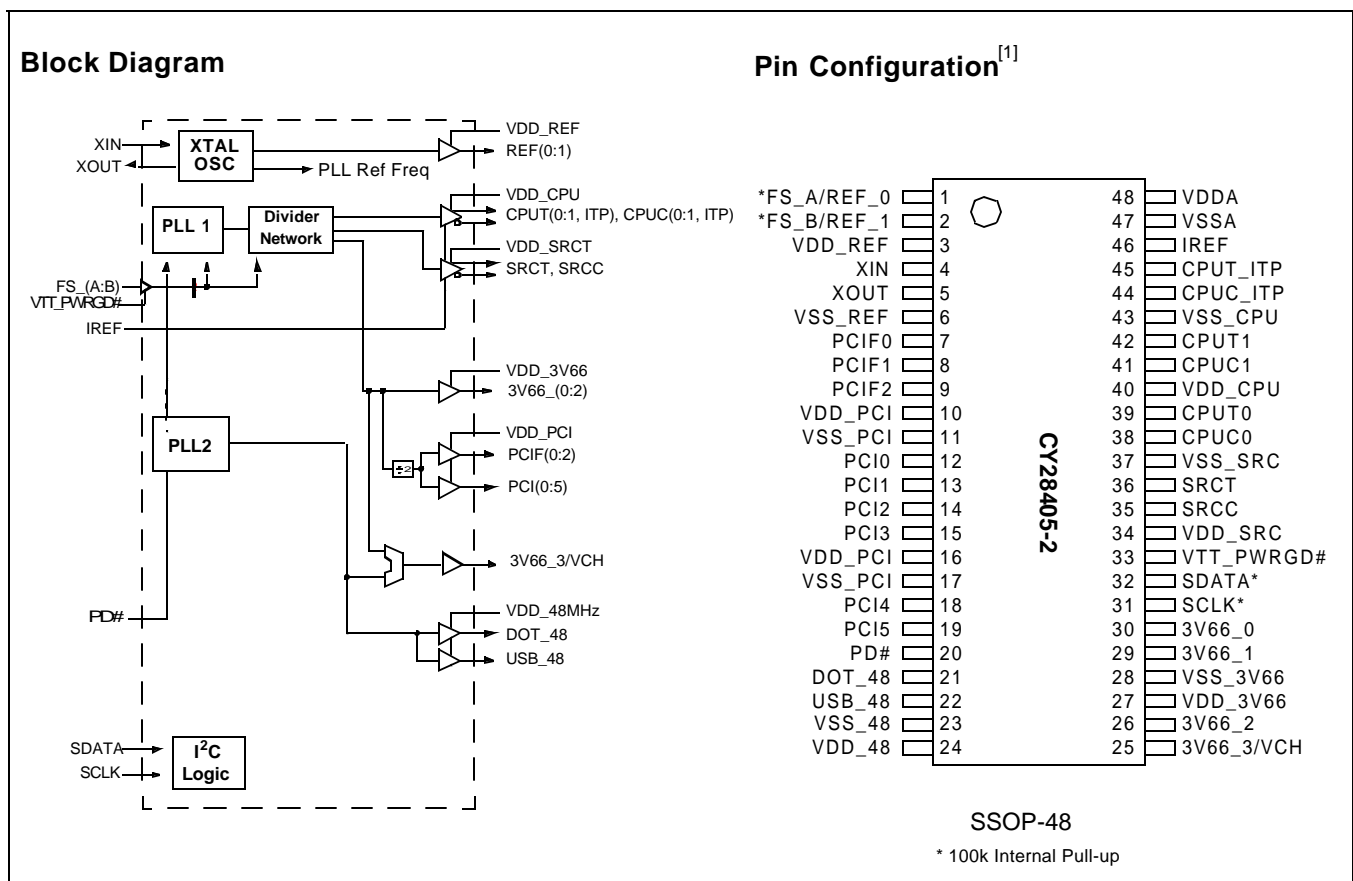

Note:
1. Signals marked with [*] and [**] have internal pull-up and pull-down resistors, respectively.

Pin Description

Pin No.	Name	Type	Description
1	FS_A/REF_0	I/O, SE	This pin is the FS_A at power-up and VTT_PWRGD# = 0, then it becomes REF_0 output. (3.3V 14.318-MHz clock output.)
2	FS_B/REF_1	I/O, SE	This pin is the FS_B at power-up and VTT_PWRGD# = 0, then it becomes REF_1 output. (3.3V 14.318-MHz clock output.)
4	XIN	I	Crystal Connection or External Reference Frequency Input. This pin has dual functions. It can be used as an external 14.318-MHz crystal connection or as an external reference frequency input.
5	XOUT	O, SE	Crystal Connection. Connection for an external 14.318-MHz crystal output.
39, 42, 38, 41, 45, 44	CPUT(0:1), CPUC(0:1), CPUT_ITP, CPUC_ITP	O, DIF	CPU Clock Output. Differential CPU clock outputs, see <i>Table 1</i> for frequency configuration.
36, 35	SRCT, SRCC	O, DIF	Differential Serial Reference Clock.
26, 29, 30	3V66(2:0)	O, SE	66-MHz Clock Output. 3.3V 66-MHz clock from internal VCO.
25	3V66_3/VCH	O, SE	48- or 66-MHz Clock Output. 3.3V selectable through SMBUS to be 66 MHz or 48 MHz. Default is 66-MHz.
7, 8, 9	PCI_F(0:2)	O, SE	Free Running PCI Output. 33-MHz clocks divided down from 3V66.
12, 13, 14, 15, 18, 19	PCI(0:5)	O, SE	PCI Clock Output. 33MHz clocks divided down from 3V66.
22	USB_48	O, SE	Fixed 48-MHz clock output.
21	DOT_48	O, SE	Fixed 48-MHz clock output.
46	IREF	I	Current Reference. A precision resistor is attached to this pin which is connected to the internal current reference.
20	PD#	I, PU	3.3V LVTTTL input for PowerDown# active low.
33	VTT_PWRGD#	I	3.3V LVTTTL input is a level sensitive strobe used to latch the FS[A:E] input (active low).
32	SDATA	I/O, PU	SMBus compatible SDATA.
31	SCLK	I, PU	SMBus compatible SCLOCK.
48	VDDA	PWR	3.3V power supply for PLL.
47	VSSA	GND	Ground for PLL.
3, 10, 16, 24, 27, 34, 40	VDD	PWR	3.3V Power supply for outputs.
6, 11, 17, 23, 28, 37, 43	VSS	GND	Ground for outputs.

Frequency Select Pins (FS_A, FS_B)

Host clock frequency selection is achieved by applying the appropriate logic levels to FS_A and FS_B inputs prior to VTT_PWRGD# assertion (as seen by the clock synthesizer). Upon VTT_PWRGD# being sampled low by the clock chip (indicating processor VTT voltage is stable), the clock chip samples the FS_A and FS_B input values. For all logic levels of FS_A and FS_B VTT_PWRGD# employs a one-shot functionality in that once a valid low on VTT_PWRGD# has been sampled low, all further VTT_PWRGD#, FS_A, and FS_B transitions will be ignored. Once "Test Clock Mode" has been invoked, all further FS_B transitions will be ignored and FS_A will asynchronously select between the Hi-Z and REF/N mode. Exiting test mode is accomplished by cycling power with FS_B in a high or low state.

Table 1. Frequency Select Table (FS_A FS_B)

FS_A	FS_B	CPU	SRC	3V66	PCIF/PCI	REF0	REF1	USB/DOT
0	0	100 MHz	100/200 MHz	66 MHz	33 MHz	14.3 MHz	14.31 MHz	48 MHz
0	B6b7	REF/N	REF/N	REF/N	REF/N	REF/N	REF/N	REF/N
0	1	200 MHz	100/200 MHz	66 MHz	33 MHz	14.3 MHz	14.31 MHz	48 MHz
1	0	133 MHz	100/200 MHz	66 MHz	33 MHz	14.3 MHz	14.31 MHz	48 MHz
1	B6b7	Hi-Z	Hi-Z	Hi-Z	Hi-Z	Hi-Z	Hi-Z	Hi-Z

Table 2. Frequency Select Table (FS_A FS_B) SMBus Bit 5 of Byte 6 = 1

FS_A	FS_B	CPU	SRC	3V66	PCIF/PCI	REF0	REF1	USB/DOT
0	0	200 MHz	100/200 MHz	66 MHz	33 MHz	14.3 MHz	14.31 MHz	48 MHz
0	1	400 MHz	100/200 MHz	66 MHz	33 MHz	14.3 MHz	14.31 MHz	48 MHz
1	0	266 MHz	100/200 MHz	66 MHz	33 MHz	14.3 MHz	14.31 MHz	48 MHz

Serial Data Interface

To enhance the flexibility and function of the clock synthesizer, a two-signal serial interface is provided. Through the Serial Data Interface, various device functions, such as individual clock output buffers, can be individually enabled or disabled. The registers associated with the Serial Data Interface initialize to their default setting upon power-up, and therefore use of this interface is optional. Clock device register changes are normally made upon system initialization, if any are required. The interface cannot be used during system operation for power management functions.

Data Protocol

The clock driver serial protocol accepts byte write, byte read, block write, and block read operations from the controller. For block write/read operation, the bytes must be accessed in sequential order from lowest to highest byte (most significant bit first) with the ability to stop after any complete byte has been transferred. For byte write and byte read operations, the system controller can access individually indexed bytes. The offset of the indexed byte is encoded in the command code, as described in *Table 3*

The block write and block read protocol is outlined in *Table 4* while *Table 5* outlines the corresponding byte write and byte read protocol. The slave receiver address is 11010010 (D2h).

Table 3. Command Code Definition

Bit	Description
7	0 = Block read or block write operation, 1 = Byte read or byte write operation
(6:0)	Byte offset for byte read or byte write operation. For block read or block write operations, these bits should be '0000000'

Table 4. Block Read and Block Write Protocol

Block Write Protocol		Block Read Protocol	
Bit	Description	Bit	Description
1	Start	1	Start
2:8	Slave address – 7 bits	2:8	Slave address – 7 bits
9	Write = 0	9	Write = 0
10	Acknowledge from slave	10	Acknowledge from slave
11:18	Command Code – 8 Bit '00000000' stands for block operation	11:18	Command Code – 8 Bit '00000000' stands for block operation
19	Acknowledge from slave	19	Acknowledge from slave
20:27	Byte Count – 8 bits	20	Repeat start
28	Acknowledge from slave	21:27	Slave address – 7 bits
29:36	Data byte 1 – 8 bits	28	Read = 1
37	Acknowledge from slave	29	Acknowledge from slave
38:45	Data byte 2 – 8 bits	30:37	Byte count from slave – 8 bits
46	Acknowledge from slave	38	Acknowledge from master
....	39:46	Data byte from slave – 8 bits

Table 4. Block Read and Block Write Protocol (continued)

Block Write Protocol		Block Read Protocol	
Bit	Description	Bit	Description
....	Data Byte (N-1) –8 bits	47	Acknowledge from master
....	Acknowledge from slave	48:55	Data byte from slave – 8 bits
....	Data Byte N –8 bits	56	Acknowledge from master
....	Acknowledge from slave	Data byte N from slave – 8 bits
....	Stop	Acknowledge from master
		Stop

Table 5. Byte Read and Byte Write Protocol

Byte Write Protocol		Byte Read Protocol	
Bit	Description	Bit	Description
1	Start	1	Start
2:8	Slave address – 7 bits	2:8	Slave address – 7 bits
9	Write = 0	9	Write = 0
10	Acknowledge from slave	10	Acknowledge from slave
11:18	Command Code – 8 bits '100xxxx' stands for byte operation, bits[6:0] of the command code represents the offset of the byte to be accessed	11:18	Command Code – 8 bits '100xxxx' stands for byte operation, bits[6:0] of the command code represents the offset of the byte to be accessed
19	Acknowledge from slave	19	Acknowledge from slave
20:27	Data byte from master – 8 bits	20	Repeat start
28	Acknowledge from slave	21:27	Slave address – 7 bits
29	Stop	28	Read = 1
		29	Acknowledge from slave
		30:37	Data byte from slave – 8 bits
		38	Acknowledge from master
		39	Stop

Byte Configuration Map

Byte 0: Control Register

Bit	@Pup	Name	Description
7	0	Reserved	Reserved, set = 0
6	1	PCIF PCI	PCI Drive Strength Override 0 = Force All PCI and PCIF Outputs to Low Drive Strength 1 = Force All PCI and PCIF Outputs to High Drive Strength
5	0	Reserved	Reserved, set = 0
4	0	Reserved	Reserved, set = 0
3	1	Reserved	Reserved, set = 1
2	1	Reserved	Reserved, set = 1
1	HW	FS_B	Power-up latched value of FS_B pin
0	HW	FS_A	Power-up latched value of FS_A pin

Byte 1: Control Register

Bit	@Pup	Name	Description
7	0	SRCT SRCC	Allow control of SRC during SW PCI_STP assertion 0 = Free Running, 1 = Stopped with SW PCI_STP
6	1	SRCT SRCC	SRC Output Enable 0 = Disabled (three-state), 1 = Enabled
5	1	Reserved	Reserved, set = 1
4	1	Reserved	Reserved, set = 1
3	1	Reserved	Reserved, set = 1
2	1	CPUT_ITP, CPUC_ITP	CPU_ITP Output Enable 0 = Disabled (three-state), 1 = Enabled
1	1	CPUT1, CPUC1	CPU(T/C)1 Output Enable, 0 = Disabled (three-state), 1 = Enabled
0	1	CPUT0, CPUC0	CPUT/C)0 Output Enable 0 = Disabled (three-state), 1 = Enabled

Byte 2: Control Register

Bit	@Pup	Name	Description
7	0	SRCT, SRCC	SRCT/C Pwrdown drive mode 0 = Driven in power-down, 1 = three-state in power-down
6	0	SRCT, SRCC	SRC Stop drive mode 0 = Driven in PCI_STP, 1 = three-state in power-down
5	0	CPUT_ITP, CPUC_ITP	CPU(T/C)_ITP Pwrdown drive mode 0 = Driven in power-down, 1 = three-state in power-down
4	0	CPUT1, CPUC1	CPU(T/C)1 Pwrdown drive mode 0 = Driven in power-down, 1 = three-state in power-down
3	0	CPUT0, CPUC0	CPU(T/C)0 Pwrdown drive mode 0 = Driven in power-down, 1 = three-state in power-down
2	0	Reserved	Reserved, set = 0
1	0	Reserved	Reserved, set = 0
0	0	Reserved	Reserved, set = 0

Byte 3: Control Register

Bit	@Pup	Name	Description
7	1	SW PCI STOP	SW PCI_STP Function 0= PCI_STP assert, 1= PCI_STP deassert When this bit is set to 0, all STOPPABLE PCI, PCIF and SRC outputs will be stopped in a synchronous manner with no short pulses. When this bit is set to 1, all STOPPED PCI,PCIF and SRC outputs will resume in a synchronous manner with no short pulses.
6	1	Reserved	Reserved
5	1	PCI5	PCI5 Output Enable 0 = Disabled, 1 = Enabled
4	1	PCI4	PCI4 Output Enable 0 = Disabled, 1 = Enabled
3	1	PCI3	PCI3 Output Enable 0 = Disabled, 1 = Enabled
2	1	PCI2	PCI2 Output Enable 0 = Disabled, 1 = Enabled
1	1	PCI1	PCI1 Output Enable 0 = Disabled, 1 = Enabled
0	1	PCI0	PCI0 Output Enable 0 = Disabled, 1 = Enabled

Byte 4: Control Register

Bit	@Pup	Name	Description
7	0	USB_48	USB_48MHz Drive Strength Control 0 = Low Drive Strength, 1 = High Drive Strength
6	1	USB_48	USB_48MHz Output Enable 0 = Disabled, 1 = Enabled
5	0	PCIF2	Allow control of PCIF2 with assertion of SW PCI_STP 0 = Free Running, 1 = Stopped with SW PCI_STP
4	0	PCIF1	Allow control of PCIF1 with assertion of SW PCI_STP 0 = Free Running, 1 = Stopped with SW PCI_STP
3	0	PCIF0	Allow control of PCIF0 with assertion of SW PCI_STP 0 = Free Running, 1 = Stopped with SW PCI_STP
2	1	PCIF2	PCIF2 Output Enable 0 = Disabled, 1 = Enabled
1	1	PCIF1	PCIF1 Output Enable 0 = Disabled, 1 = Enabled
0	1	PCIF0	PCIF0 Output Enable 0 = Disabled, 1 = Enabled

Byte 5: Control Register

Bit	@Pup	Name	Description
7	1	DOT_48	DOT_48MHz Output Enable 0 = Disabled, 1 = Enabled
6	1	Reserved	Reserved, set = 1
5	0	3V66_3/VCH	3V66_3/VCH Frequency Select 0 = 3V66 mode, 1 = VCH (48MHz) mode
4	1	3V66_3/VCH	3V66_3/VCH Output Enable 0 = Disabled, 1 = Enabled
3	1	Reserved	Reserved, set = 1
2	1	3V66_2	3V66_2 Output Enable 0 = Disabled, 1 = Enabled
1	1	3V66_1	3V66_1 Output Enable 0 = Disabled, 1 = Enabled
0	1	3V66_0	3V66_0 Output Enable 0 = Disabled, 1 = Enabled

Byte 6: Control Register

Bit	@Pup	Name	Description
7	0	Reserved	Reserved, set = 0
6	0	Reserved	Reserved, set = 0
5	0	CPUC0, CPUT0 CPUC1, CPUT1 CPUT_ITP, CPUC_ITP	FS_A & FS_B Operation 0 = Normal, 1 = Test mode
4	0	SRCT, SRCC	SRCT/C Frequency Select 0 = 100Mhz, 1 = 200MHz
3	0	PCIF PCI 3V66 SRCT,SRCC CPUT_ITP,CPUC_ITP	Spread Spectrum Mode 0 = down (default), 1 = center

Byte 6: Control Register (continued)

Bit	@Pup	Name	Description
2	0	PCIF PCI 3V66 SRCT,SRCC CPUT_ITP,CPUC_ITP	Spread Spectrum Enable 0 = Spread Off, 1 = Spread On
1	1	REF_1	REF_1 Output Enable 0 = Disabled, 1 = Enabled
0	1	REF_0	REF_0 Output Enable 0 = Disabled, 1 = Enabled

Byte 7: Control Register

Bit	@Pup	Name	Description
7	0	Revision ID Bit 3	Revision ID Bit 3
6	1	Revision ID Bit 2	Revision ID Bit 2
5	0	Revision ID Bit 1	Revision ID Bit 1
4	0	Revision ID Bit 0	Revision ID Bit 0
3	1	Vendor ID Bit 3	Vendor ID Bit 3
2	0	Vendor ID Bit 2	Vendor ID Bit 2
1	0	Vendor ID Bit 1	Vendor ID Bit 1
0	0	Vendor ID Bit 0	Vendor ID Bit 0

Crystal Recommendations

The CY28405-2 requires a **Parallel Resonance Crystal**. Substituting a series resonance crystal will cause the CY28405-2 to operate at the wrong frequency and violate the ppm specification. For most applications there is a 300-ppm frequency shift between series and parallel crystals due to incorrect loading.

Table 6. Crystal Recommendations

Frequency (Fund)	Cut	Loading	Load Cap	Drive (max.)	Shunt Cap (max.)	Motional (max.)	Tolerance (max.)	Stability (max.)	Aging (max.)
14.31818 MHz	AT	Parallel	20 pF	0.1 mW	5 pF	0.016 pF	50 ppm	50 ppm	5 ppm

Crystal Loading

Crystal loading plays a critical role in achieving low ppm performance. To realize low ppm performance, the total capacitance the crystal will see must be considered to calculate the appropriate capacitive loading (CL).

The following diagram shows a typical crystal configuration using the two trim capacitors. An important clarification for the following discussion is that the trim capacitors are in series with the crystal not parallel. It's a common misconception that load capacitors are in parallel with the crystal and should be approximately equal to the load capacitance of the crystal. This is **not true**.

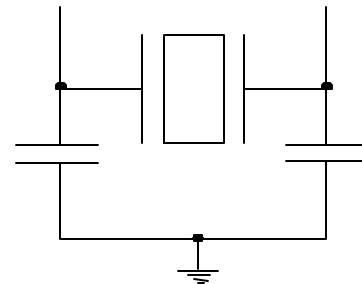
Figure 1. Crystal Capacitive Clarification

Calculating Load Capacitors

In addition to the standard external trim capacitors, trace capacitance and pin capacitance must also be considered to correctly calculate crystal loading. As mentioned previously, the capacitance on each side of the crystal is in series with the crystal. This means the total capacitance on each side of the crystal must be twice the specified crystal load capacitance (CL). While the capacitance on each side of the crystal is in series with the crystal, trim capacitors (Ce1,Ce2) should be calculated to provide equal capacitive loading on both sides.

As mentioned previously, the capacitance on each side of the crystal is in series with the crystal. This means the total capacitance on each side of the crystal must be twice the specified load capacitance (CL). While the capacitance on each side of the crystal is in series with the crystal, trim capacitors (Ce1,Ce2) should be calculated to provide equal capacitive loading on both sides.

Use the following formulas to calculate the trim capacitor values for Ce1 and Ce2.

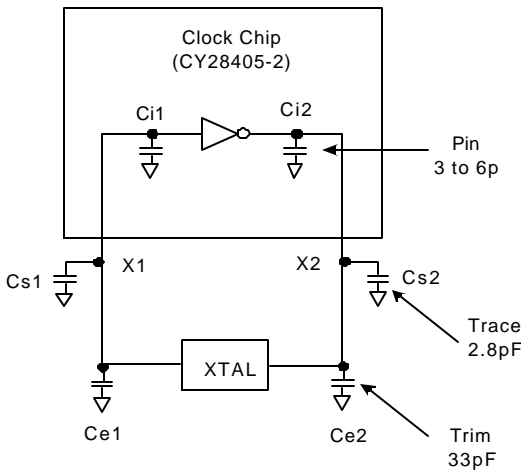

Figure 2. Crystal Loading Example

Load Capacitance (each side)

$$C_e = 2 * CL - (C_s + C_i)$$

Total Capacitance (as seen by the crystal)

$$C_{Le} = \frac{1}{\left(\frac{1}{C_{e1} + C_{s1} + C_{i1}} + \frac{1}{C_{e2} + C_{s2} + C_{i2}} \right)}$$

- CLCrystal load capacitance
- CLe Actual loading seen by crystal
..... using standard value trim capacitors
- Ce External trim capacitors
- Cs Stray capacitance (trace, etc)
- Ci Internal capacitance (lead frame, bond wires etc)

PD# (Power-down) Clarification

The PD# (Power Down) pin is used to shut off ALL clocks prior to shutting off power to the device. PD# is an asynchronous active LOW input. This signal is synchronized internally to the device powering down the clock synthesizer. PD# is an asynchronous function for powering up the system. When PD#

is low, all clocks are driven to a LOW value and held there and the VCO and PLLs are also powered down. All clocks are shut down in a synchronous manner so has not to cause glitches while transitioning to the low 'stopped' state.

PD# – Assertion

When PD# is sampled low by two consecutive rising edges of CPUC clock then all clock outputs (except CPU) clocks must be held low on their next high to low transition. CPU clocks must be held with CPU clock pin driven high with a value of 2x Iref and CPUC undriven.

Due to the state of internal logic, stopping and holding the REF clock outputs in the LOW state may require more than one clock cycle to complete.

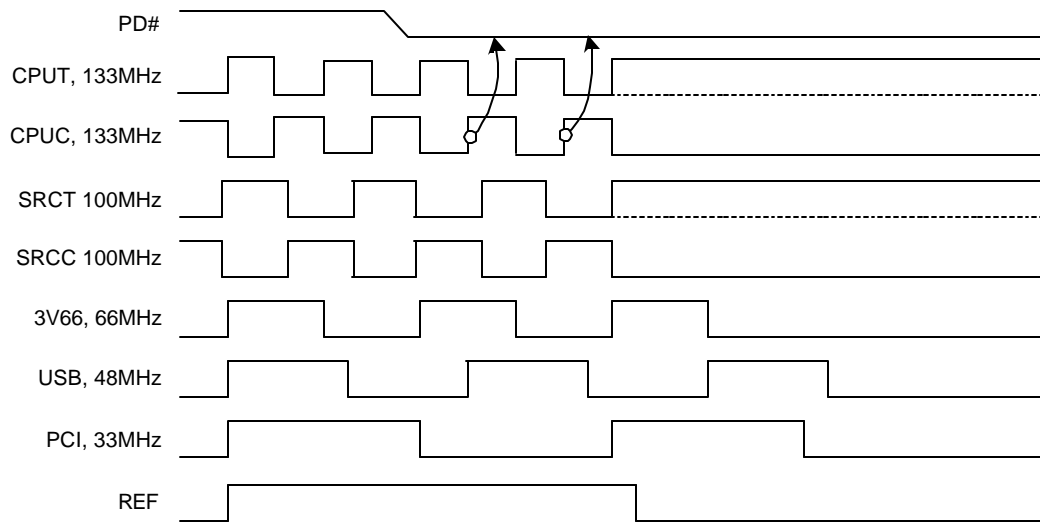

Figure 3. Power-down Assertion Timing Waveforms

PD# Deassertion

The power-up latency between PD# rising to a valid logic '1' level and the starting of all clocks is less than 3.0 ms.

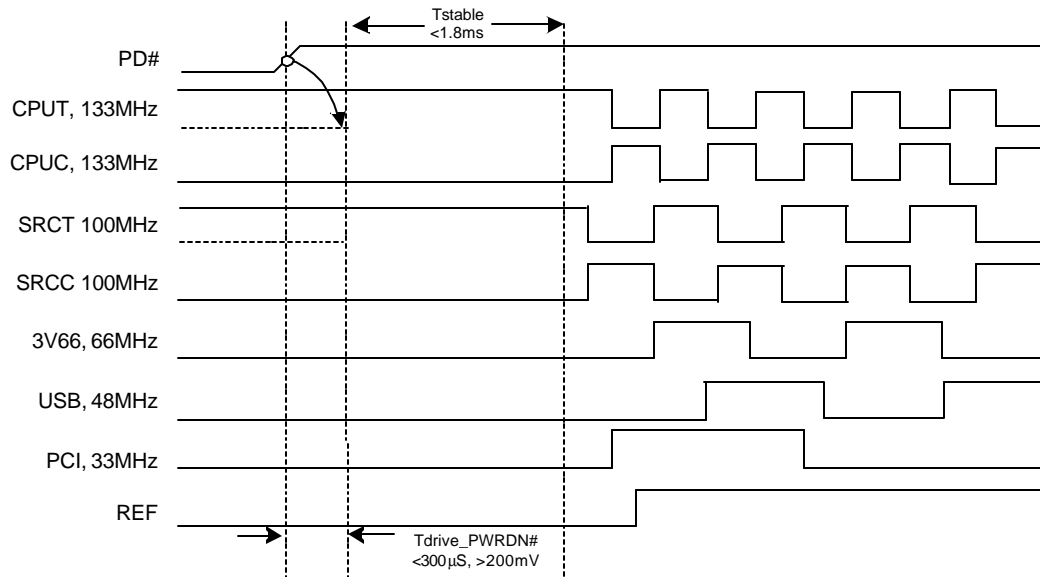

Figure 4. Power-down Deassertion Timing Waveforms

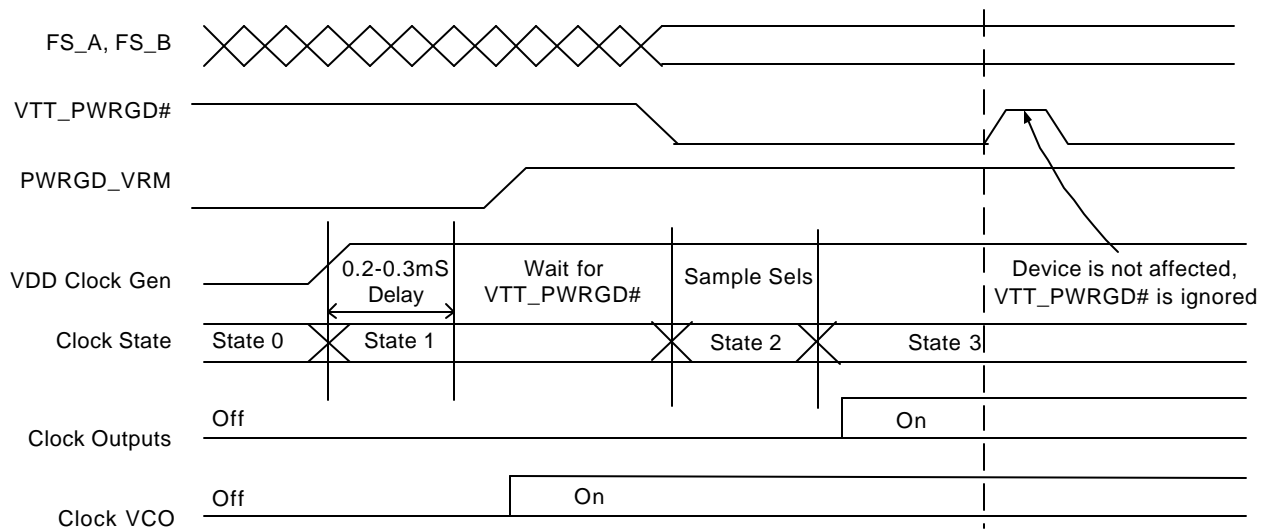

Figure 5.VTT_PWRGD# Timing Diagram

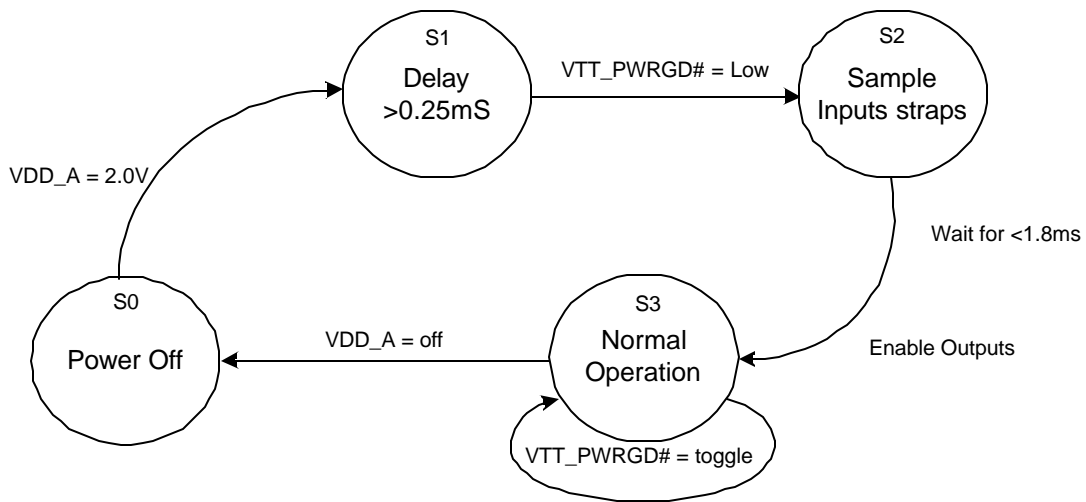

Figure 6.Clock Generator Power-up/Run State Diagram

Absolute Maximum Conditions

Parameter	Description	Condition	Min.	Max.	Unit
V _{DD}	Core Supply Voltage		-0.5	4.6	V
V _{DDA}	Analog Supply Voltage		-0.5	4.6	V
V _{IN}	Input Voltage	Relative to V _{SS}	-0.5	V _{DD} + 0.5	VDC
T _S	Temperature, Storage	Non-functional	-65	+150	°C
T _A	Temperature, Operating Ambient	Functional	0	70	°C
T _J	Temperature, Junction	Functional	-	150	°C
ESD _{HBM}	ESD Protection (Human Body Model)	MIL-STD-883, Method 3015	2000	-	V
∅ _{JC}	Dissipation, Junction to Case	Mil-Spec 883E Method 1012.1	36.9		°C/W
∅ _{JA}	Dissipation, Junction to Ambient	JEDEC (JESD 51)	83.5		°C/W
UL-94	Flammability Rating	At 1/8 in.	V-0		
MSL	Moisture Sensitivity Level		1		

Multiple Supplies: The Voltage on any input or I/O pin cannot exceed the power pin during power-up. Power supply sequencing is NOT required.

DC Electrical Specifications

Parameter	Description	Condition	Min.	Max.	Unit
V _{DD} , V _{DDA}	3.3 Operating Voltage	3.3V ± 5%	3.135	3.465	V
V _{IL2C}	Input Low Voltage	SDATA, SCLK	-	1.0	V
V _{IH2C}	Input High Voltage	SDATA, SCLK	2.2	-	V
V _{IL}	Input Low Voltage		V _{SS} -0.5	0.8	V
V _{IH}	Input High Voltage		2.0	V _{DD} +0.5	V
I _{IL}	Input Leakage Current	except Pull-ups or Pull downs 0 < V _{IN} < V _{DD}	-5	5	µA
V _{OL}	Output Low Voltage	I _{OL} = 1 mA	-	0.4	V
V _{OH}	Output High Voltage	I _{OH} = -1 mA	2.4	-	V
I _{OZ}	High-Impedance Output Current		-10	10	µA
C _{IN}	Input Pin Capacitance		2	5	pF
C _{OUT}	Output Pin Capacitance		3	6	pF
L _{IN}	Pin Inductance		-	7	nH
V _{XIH}	Xin High Voltage		0.7V _{DD}	V _{DD}	V
V _{XIL}	Xin Low Voltage		0	0.3V _{DD}	V
I _{DD}	Dynamic Supply Current	At 200 MHz and all outputs loaded per <i>Table 9</i> and <i>Figure 7</i>	-	350	mA
I _{PD}	Power-down Supply Current	PD# asserted, all differential outputs three-stated.	-	1	mA

AC Electrical Specifications

Parameter	Description	Condition	Min.	Max.	Unit
Crystal					
T _{DC}	XIN Duty Cycle	The device will operate reliably with input duty cycles up to 30/70 but the REF clock duty cycle will not be within specification	47.5	52.5	%
T _{PERIOD}	XIN period	When Xin is driven from an external clock source	69.841	71.0	ns

AC Electrical Specifications (continued)

Parameter	Description	Condition	Min.	Max.	Unit
T_R / T_F	XIN Rise and Fall Times	Measured between $0.3V_{DD}$ and $0.7V_{DD}$	–	10.0	ns
T_{CCJ}	XIN Cycle to Cycle Jitter	As an average over $1\mu s$ duration	–	500	ps
L_{ACC}	Long Term Accuracy	Over 150 ms	–	300	ppm
CPU at 0.7V					
T_{DC}	CPUT and CPUC Duty Cycle	Measured at crossing point V_{OX}	45	55	%
T_{PERIOD}	100-MHz CPUT and CPUC Period	Measured at crossing point V_{OX}	9.9970	10.003	ns
T_{PERIOD}	133-MHz CPUT and CPUC Period	Measured at crossing point V_{OX}	7.4978	7.5023	ns
T_{PERIOD}	200-MHz CPUT and CPUC Period	Measured at crossing point V_{OX}	4.9985	5.0015	ns
T_{SKEW}	Any CPUT/C to CPUT/C Clock Skew	Measured at crossing point V_{OX}	–	100	ps
T_{CCJ}	CPUT/C Cycle to Cycle Jitter	Measured at crossing point V_{OX}	–	125	ps
T_R / T_F	CPUT and CPUC Rise and Fall Times	Measured from $V_{ol} = 0.175$ to $V_{oh} = 0.525V$	175	700	ps
T_{RFM}	Rise/Fall Matching	Determined as a fraction of $2*(T_R - T_F)/(T_R + T_F)$	–	20	%
ΔT_R	Rise Time Variation		–	125	ps
ΔT_F	Fall Time Variation		–	125	ps
V_{HIGH}	Voltage High	Math averages <i>Figure 7</i>	660	850	mV
V_{LOW}	Voltage Low	Math averages <i>Figure 7</i>	–150	–	mV
V_{OX}	Crossing Point Voltage at 0.7V Swing		250	550	mV
V_{OVS}	Maximum Overshoot Voltage		–	$V_{HIGH} + 0.3$	V
V_{UDS}	Minimum Undershoot Voltage		–0.3	–	V
V_{RB}	Ring Back Voltage	See <i>Figure 7</i> . Measure SE	–	0.2	V
SRC					
T_{DC}	SRCT and SRCC Duty Cycle	Measured at crossing point V_{OX}	45	55	%
T_{PERIOD}	100 MHz SRCT and SRCC Period	Measured at crossing point V_{OX}	9.9970	10.003	ns
T_{PERIOD}	200 MHz SRCT and SRCC Period	Measured at crossing point V_{OX}	4.9985	5.0015	ns
L_{ACC}	Long Term Accuracy	Measured at crossing point V_{OX}	–	300	ppm
T_{CCJ}	SRCT/C Cycle to Cycle Jitter	Measured at crossing point V_{OX}	–	125	ps
T_R / T_F	SRCT and SRCC Rise and Fall Times	Measured from $V_{ol} = 0.175$ to $V_{oh} = 0.525V$	175	700	ps
T_{RFM}	Rise/Fall Matching	Determined as a fraction of $2*(T_R - T_F)/(T_R + T_F)$	–	20	%
ΔT_R	Rise Time Variation		–	125	ps
ΔT_F	Fall Time Variation		–	125	ps
V_{HIGH}	Voltage High	Math averages <i>Figure 7</i>	660	850	mV
V_{LOW}	Voltage Low	Math averages <i>Figure 7</i>	–150	–	mV
V_{OX}	Crossing Point Voltage at 0.7V Swing		250	550	mV
V_{OVS}	Maximum Overshoot Voltage		–	$V_{HIGH} + 0.3$	V
V_{UDS}	Minimum Undershoot Voltage		–0.3	–	V
V_{RB}	Ring Back Voltage	See <i>Figure 7</i> . Measure SE	–	0.2	V

AC Electrical Specifications (continued)

Parameter	Description	Condition	Min.	Max.	Unit
3V66					
T _{DC}	3V66 Duty Cycle	Measurement at 1.5V	45	55	%
T _{PERIOD}	Spread Disabled 3V66 Period	Measurement at 1.5V	14.9955	15.0045	ns
T _{PERIOD}	Spread Enabled 3V66 Period	Measurement at 1.5V	14.9955	15.0799	ns
T _{HIGH}	3V66 High Time	Measurement at 2.0V	4.9500	–	ns
T _{LOW}	3V66 Low Time	Measurement at 0.8V	4.5500	–	ns
T _R / T _F	3V66 Rise and Fall Times	Measured between 0.8V and 2.0V	0.5	2.0	ns
T _{SKEW}	Any 3V66 to Any 3V66 Clock Skew	Measurement at 1.5V	–	250	ps
T _{CCJ}	3V66 Cycle to Cycle Jitter	Measurement at 1.5V	–	250	ps
PCI/PCIF					
T _{DC}	PCI Duty Cycle	Measurement at 1.5V	45	55	%
T _{PERIOD}	Spread Disabled PCIF/PCI Period	Measurement at 1.5V	29.9910	30.0009	ns
T _{PERIOD}	Spread Enabled PCIF/PCI Period	Measurement at 1.5V	29.9910	30.1598	ns
T _{HIGH}	PCIF and PCI High Time	Measurement at 2.0V	12.0	–	ns
T _{LOW}	PCIF and PCI Low Time	Measurement at 0.8V	12.0	–	ns
T _R / T _F	PCIF and PCI Rise and Fall Times	Measured between 0.8V and 2.0V	0.5	2.0	ns
T _{SKEW}	Any PCI clock to Any PCI Clock Skew	Measurement at 1.5V	–	500	ps
T _{CCJ}	PCIF and PCI Cycle to Cycle Jitter	Measurement at 1.5V	–	250	ps
DOT					
T _{DC}	Duty Cycle	Measurement at 1.5V	45	55	%
T _{PERIOD}	Period	Measurement at 1.5V	20.8271	20.8396	ns
T _{HIGH}	USB High Time	Measurement at 2.0V	8.094	10.036	ns
T _{LOW}	USB Low Time	Measurement at 0.8V	7.694	9.836	ns
T _R / T _F	Rise and Fall Times	Measured between 0.8V and 2.0V	1.0	2.0	ns
T _{CCJ}	Cycle to Cycle Jitter	Measurement at 1.5V	–	350	ps
T _{SKEW}	Any 48 MHz to 48 MHz clock skew	Measurement @ 1.5V	–	500	ps
USB					
T _{DC}	Duty Cycle	Measurement at 1.5V	45	55	%
T _{PERIOD}	Period	Measurement at 1.5V	20.8271	20.8396	ns
T _{HIGH}	USB High Time	Measurement at 2.0V	8.094	10.036	ns
T _{LOW}	USB Low Time	Measurement at 0.8V	7.694	9.836	ns
T _R / T _F	Rise and Fall Times	Measured between 0.8V and 2.0V	1.0	2.0	ns
T _{CCJ}	Cycle to Cycle Jitter	Measurement at 1.5V	–	350	ps
T _{SKEW}	Any 48 MHz to 48 MHz Clock Skew	Measurement @ 1.5V	–	500	ps
REF					
T _{DC}	REF Duty Cycle	Measurement at 1.5V	45	55	%
T _{PERIOD}	REF Period	Measurement at 1.5V	69.827	69.855	ns
T _R / T _F	REF Rise and Fall Times	Measured between 0.8V and 2.0V	1.0	4.0	V/ns
T _{CCJ}	REF Cycle to Cycle Jitter	Measurement at 1.5V	–	1000	ps
T _{SKEW}	Any REF to REF clock skew	Measurement @ 1.5V	–	500	ps

AC Electrical Specifications (continued)

Parameter	Description	Condition	Min.	Max.	Unit
ENABLE/DISABLE and SET-UP					
T _{STABLE}	Clock Stabilization from Power-up		–	1.8	ms
T _{SS}	Stopclock Set-up Time		10.0	–	ns
T _{SH}	Stopclock Hold Time		0	–	ns

Table 7. Group Timing Relationship and Tolerances

Group	Conditions	Offset	
		Min.	Max.
3V66 to PCI	3V66 Leads PCI	1.5ns	3.5ns

Table 8. USB to DOT Phase Offset

Parameter	Typical	Value	Tolerance
DOT Skew	0°	0.0ns	1000ps
USB Skew	180°	0.0ns	1000ps
VCH Skew	0°	0.0ns	1000ps

Test and Measurement Set-up

Table 9. Maximum Lumped Capacitive Output Loads

Clock	Max Load	Units
PCI Clocks	30	pF
3V66 Clocks	30	pF
USB Clock	20	pF
DOT Clock	10	pF
REF Clock	30	pF

For Differential CPU and SRC Output Signals

The following diagram shows lumped test load configurations for the differential Host Clock Outputs.

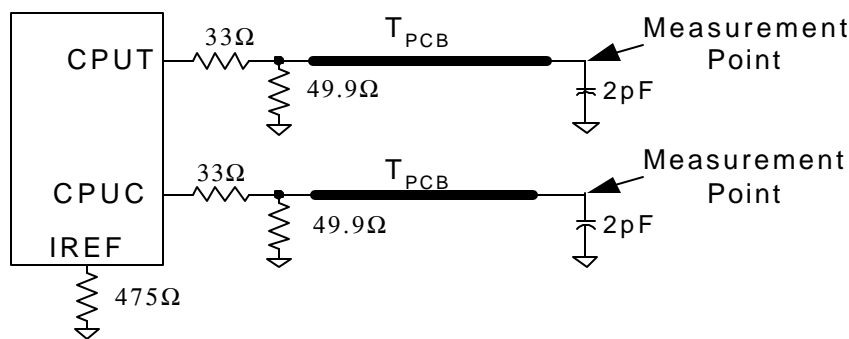

Figure 7.0.7V Load Configuration

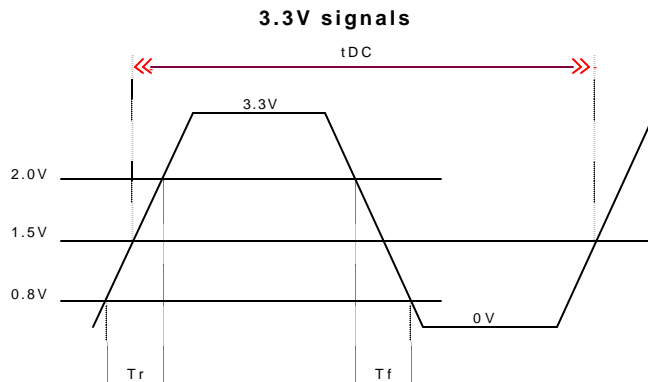
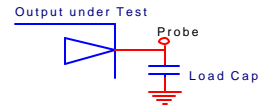

Figure 8. Lumped Load For Single-ended Output Signals (for AC Parameters Measurement)

Table 10. CPU Clock Current Select Function

Board Target Trace/Term Z	Reference R, $I_{REF} = V_{DD} / (3 * R_{REF})$	Output Current	$V_{OH} @ Z$
50 Ohms	$R_{REF} = 475 \%, I_{REF} = 2.32mA$	$I_{OH} = 6 * I_{REF}$	0.7V @ 50

Ordering Information

Part Number	Package Type	Product Flow
CY28405OC-2	48-pin SSOP	Commercial, 0° to 70°C
CY28405OC-2T	48-pin SSOP – Tape and Reel	Commercial, 0° to 70°C

Package Drawing and Dimensions

48-lead Shrink Small Outline Package O48

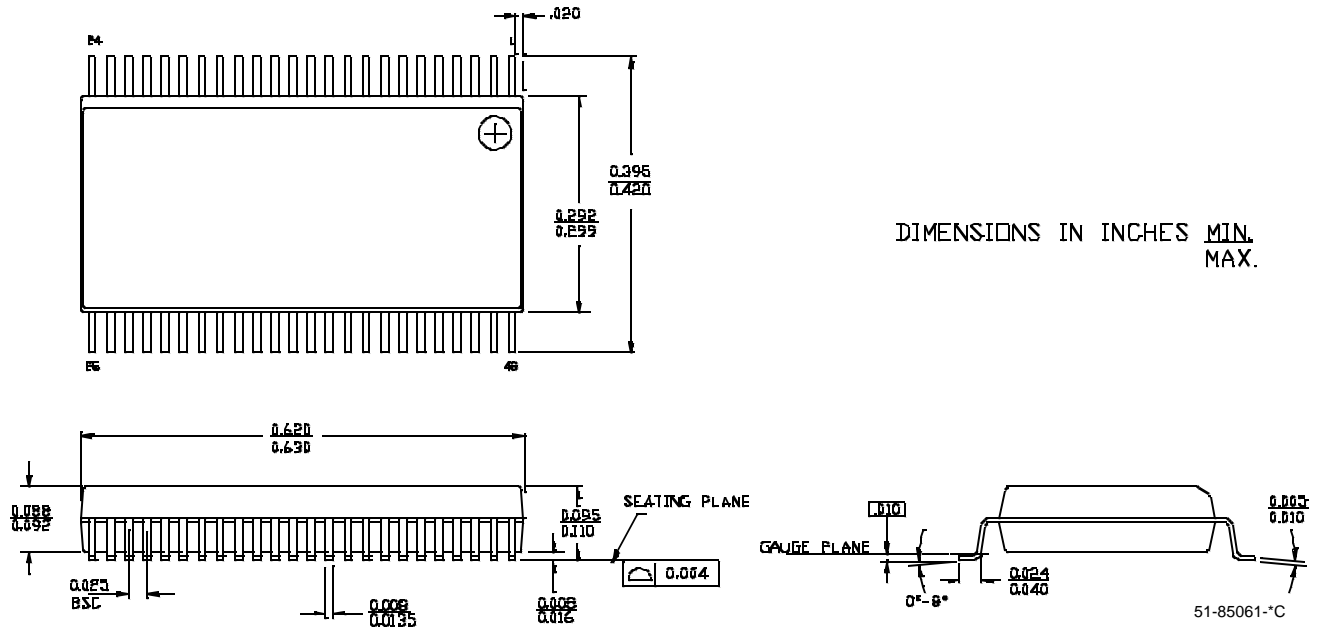

Purchase of I²C components from Cypress, or one of its sublicensed Associated Companies, conveys a license under the Philips I²C Patent Rights to use these components in an I²C system, provided that the system conforms to the I²C Standard Specification as defined by Philips. Intel and Pentium are registered trademarks of Intel Corporation. All product and company names mentioned in this document are the trademarks of their respective holders.

Document History Page

Document Title: CY28405-2 Clock Synthesizer with Differential SRC and CPU Outputs				
Document Number: 38-07511				
REV.	ECN NO.	Issue Date	Orig. of Change	Description of Change
**	125353	04/15/03	RGL	New Data Sheet
*A	126308	07/16/03	RGL	Fixed typos
*B	128641	08/27/03	RGL	Specified "Pull-up" function for the SCLK and SDATA in the Pin Description table
*C	129643	10/01/03	RGL	Changed the voltage threshold on the single-ended output from 2.4V to 2.0 and from 0.4V to 0.8V