

# SN74LVTH32374-EP

## 3.3-V ABT 32-BIT EDGE-TRIGGERED D-TYPE FLIP-FLOP WITH 3-STATE OUTPUTS

SCBS795 – DECEMBER 2003

- **Controlled Baseline**
  - One Assembly/Test Site, One Fabrication Site
- **Enhanced Diminishing Manufacturing Sources (DMS) Support**
- **Enhanced Product-Change Notification**
- **Qualification Pedigree†**
- **State-of-the-Art Advanced BiCMOS Technology (ABT) Design for 3.3-V Operation and Low Static-Power Dissipation**
- **Member of the Texas Instruments Widebus+™ Family**
- **Typical  $V_{OLP}$  (Output Ground Bounce) <0.8 V at  $V_{CC} = 3.3$  V,  $T_A = 25^\circ\text{C}$**
- **$I_{off}$  and Power-Up 3-State Support Hot Insertion**
- **Supports Mixed-Mode Signal Operation on All Ports (5-V Input and Output Voltages With 3.3-V  $V_{CC}$ )**
- **Bus Hold on Data Inputs Eliminates the Need for External Pullup/Pulldown Resistors**
- **Supports Unregulated Battery Operation Down To 2.7 V**

† Component qualification in accordance with JEDEC and industry standards to ensure reliable operation over an extended temperature range. This includes, but is not limited to, Highly Accelerated Stress Test (HAST) or biased 85/85, temperature cycle, autoclave or unbiased HAST, electromigration, bond intermetallic life, and mold compound life. Such qualification testing should not be viewed as justifying use of this component beyond specified performance and environmental limits.

**GKE PACKAGE  
(TOP VIEW)**

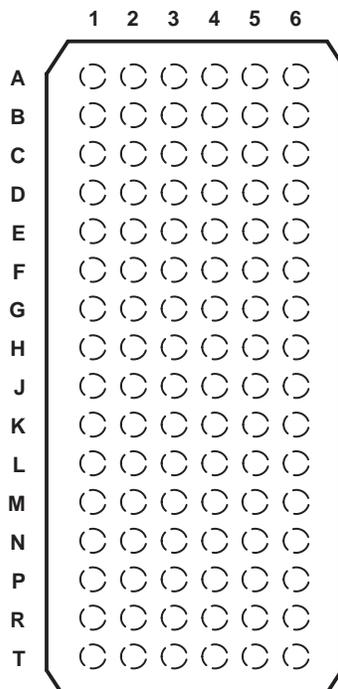

**terminal assignments**

	1	2	3	4	5	6
A	1Q2	1Q1	1 $\overline{OE}$	1CLK	1D1	1D2
B	1Q4	1Q3	GND	GND	1D3	1D4
C	1Q6	1Q5	1 $V_{CC}$	1 $V_{CC}$	1D5	1D6
D	1Q8	1Q7	GND	GND	1D7	1D8
E	2Q2	2Q1	GND	GND	2D1	2D2
F	2Q4	2Q3	1 $V_{CC}$	1 $V_{CC}$	2D3	2D4
G	2Q6	2Q5	GND	GND	2D5	2D6
H	2Q7	2Q8	2 $\overline{OE}$	2CLK	2D8	2D7
J	3Q2	3Q1	3 $\overline{OE}$	3CLK	3D1	3D2
K	3Q4	3Q3	GND	GND	3D3	3D4
L	3Q6	3Q5	2 $V_{CC}$	2 $V_{CC}$	3D5	3D6
M	3Q8	3Q7	GND	GND	3D7	3D8
N	4Q2	4Q1	GND	GND	4D1	4D2
P	4Q4	4Q3	2 $V_{CC}$	2 $V_{CC}$	4D3	4D4
R	4Q6	4Q5	GND	GND	4D5	4D6
T	4Q7	4Q8	4 $\overline{OE}$	4CLK	4D8	4D7



Please be aware that an important notice concerning availability, standard warranty, and use in critical applications of Texas Instruments semiconductor products and disclaimers thereto appears at the end of this data sheet.

Widebus+ is a trademark of Texas Instruments.

**PRODUCTION DATA** information is current as of publication date. Products conform to specifications per the terms of Texas Instruments standard warranty. Production processing does not necessarily include testing of all parameters.



POST OFFICE BOX 655303 • DALLAS, TEXAS 75265

Copyright © 2003, Texas Instruments Incorporated

# SN74LVTH32374-EP

## 3.3-V ABT 32-BIT EDGE-TRIGGERED D-TYPE FLIP-FLOP WITH 3-STATE OUTPUTS

SCBS795 – DECEMBER 2003

### description/ordering information

The SN74LVTH32374 is a 32-bit edge-triggered D-type flip-flop designed for low-voltage (3.3-V)  $V_{CC}$  operation, but with the capability to provide a TTL interface to a 5-V system environment. This device is particularly suitable for implementing buffer registers, I/O ports, bidirectional bus drivers, and working registers.

This device can be used as four 8-bit flip-flops, two 16-bit flip-flops, or one 32-bit flip-flop. On the positive transition of the clock (CLK), the Q outputs of the flip-flop take on the logic levels set up at the data (D) inputs.

A buffered output-enable ( $\overline{OE}$ ) input can be used to place the eight outputs in either a normal logic state (high or low logic levels) or the high-impedance state. In the high-impedance state, the outputs neither load nor drive the bus lines significantly. The high-impedance state and increased drive provide the capability to drive bus lines without interface or pullup components.

$\overline{OE}$  does not affect internal operations of the flip-flop. Old data can be retained or new data can be entered while the outputs are in the high-impedance state.

When  $V_{CC}$  is between 0 and 1.5 V, the device is in the high-impedance state during power up or power down. However, to ensure the high-impedance state above 1.5 V,  $\overline{OE}$  should be tied to  $V_{CC}$  through a pullup resistor; the minimum value of the resistor is determined by the current-sinking capability of the driver.

This device is fully specified for hot-insertion applications using  $I_{off}$  and power-up 3-state. The  $I_{off}$  circuitry disables the outputs, preventing damaging current backflow through the device when it is powered down. The power-up 3-state circuitry places the outputs in the high-impedance state during power up and power down, which prevents driver conflict.

Active bus-hold circuitry holds unused or undriven inputs at a valid logic state. Use of pullup or pulldown resistors with the bus-hold circuitry is not recommended.

### ORDERING INFORMATION

TA	PACKAGE†		ORDERABLE PART NUMBER	TOP-SIDE MARKING
-40°C to 85°C	LFBGA – GKE	Tape and reel	CLVTH32374IGKEREP	L374EP

† Package drawings, standard packing quantities, thermal data, symbolization, and PCB design guidelines are available at [www.ti.com/sc/package](http://www.ti.com/sc/package).

FUNCTION TABLE  
(each 8-bit flip-flop)

INPUTS			OUTPUT
$\overline{OE}$	CLK	D	Q
L	↑	H	H
L	↑	L	L
L	H or L	X	$Q_0$
H	X	X	Z



**SN74LVTH32374-EP**  
**3.3-V ABT 32-BIT EDGE-TRIGGERED D-TYPE FLIP-FLOP**  
**WITH 3-STATE OUTPUTS**

SCBS795 - DECEMBER 2003

**logic diagram (positive logic)**

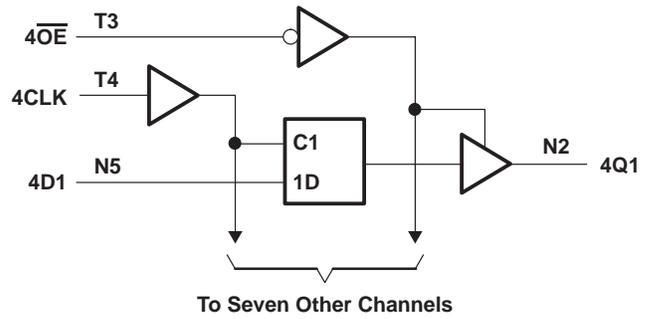
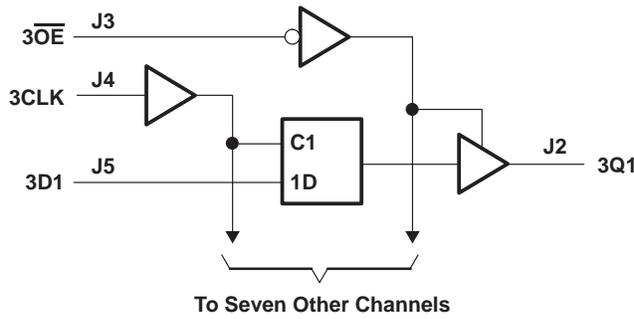
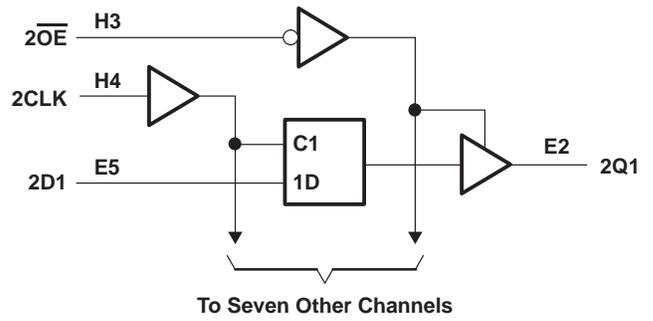
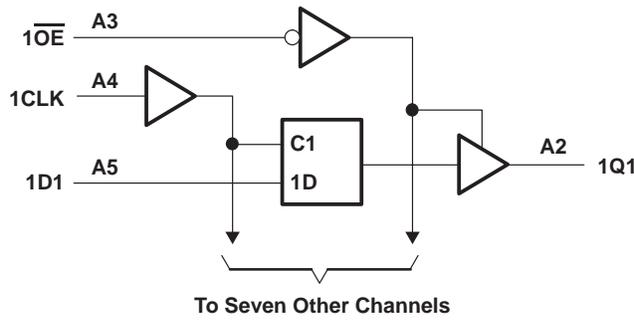

**SN74LVTH32374-EP**  
**3.3-V ABT 32-BIT EDGE-TRIGGERED D-TYPE FLIP-FLOP**  
**WITH 3-STATE OUTPUTS**

SCBS795 – DECEMBER 2003

**absolute maximum ratings over operating free-air temperature range (unless otherwise noted)†**

Supply voltage range, $V_{CC}$ .....	-0.5 V to 4.6 V
Input voltage range, $V_I$ (see Note 1) .....	-0.5 V to 7 V
Voltage range applied to any output in the high-impedance or power-off state, $V_O$ (see Note 1) .....	-0.5 V to 7 V
Voltage range applied to any output in the high state, $V_O$ (see Note 1) .....	-0.5 V to $V_{CC} + 0.5$ V
Current into any output in the low state, $I_O$ .....	128 mA
Current into any output in the high state, $I_O$ (see Note 2) .....	64 mA
Input clamp current, $I_{IK}$ ( $V_I < 0$ ) .....	-50 mA
Output clamp current, $I_{OK}$ ( $V_O < 0$ ) .....	-50 mA
Package thermal impedance, $\theta_{JA}$ (see Note 3) .....	40°C/W
Storage temperature range, $T_{stg}$ (see Note 4) .....	-65°C to 150°C

† Stresses beyond those listed under “absolute maximum ratings” may cause permanent damage to the device. These are stress ratings only, and functional operation of the device at these or any other conditions beyond those indicated under “recommended operating conditions” is not implied. Exposure to absolute-maximum-rated conditions for extended periods may affect device reliability.

- NOTES: 1. The input and output negative-voltage ratings may be exceeded if the input and output clamp-current ratings are observed.  
 2. This current flows only when the output is in the high state and  $V_O > V_{CC}$ .  
 3. The package thermal impedance is calculated in accordance with JESD 51-7.  
 4. Long-term high-temperature storage and/or extended use at maximum recommended operating conditions may result in a reduction of overall device life. See Figure 1 for additional information on thermal derating.

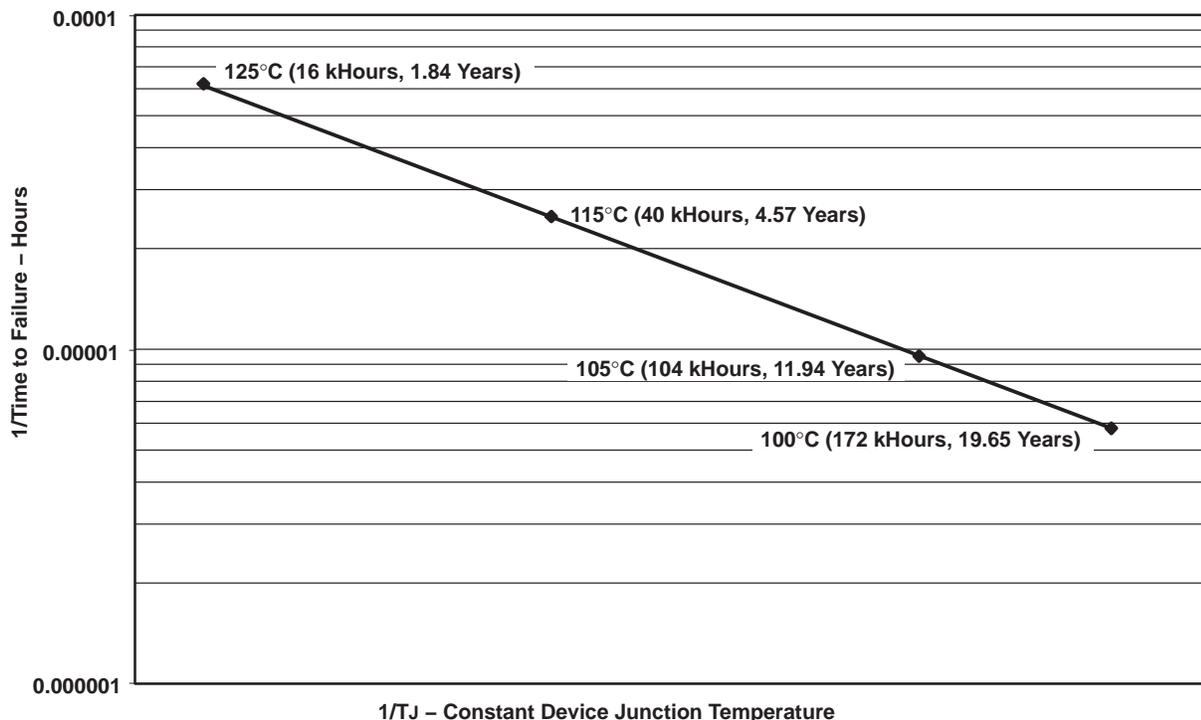

**Figure 1. Estimated Wirebond Life**  
**Based on Elevated-Temperature Kirkendall-Voiding Failure Mode**



**SN74LVTH32374-EP**  
**3.3-V ABT 32-BIT EDGE-TRIGGERED D-TYPE FLIP-FLOP**  
**WITH 3-STATE OUTPUTS**

SCBS795 – DECEMBER 2003

**recommended operating conditions (see Note 5)**

		MIN	MAX	UNIT	
V <sub>CC</sub>	Supply voltage	2.7	3.6	V	
V <sub>IH</sub>	High-level input voltage	2		V	
V <sub>IL</sub>	Low-level input voltage		0.8	V	
V <sub>I</sub>	Input voltage		5.5	V	
I <sub>OH</sub>	High-level output current		-32	mA	
I <sub>OL</sub>	Low-level output current		64	mA	
Δt/Δv	Input transition rise or fall rate	Outputs enabled		10	ns/V
Δt/ΔV <sub>CC</sub>	Power-up ramp rate	200			μs/V
T <sub>A</sub>	Operating free-air temperature	-40	85		°C

NOTE 5: All unused control inputs of the device must be held at V<sub>CC</sub> or GND to ensure proper device operation. Refer to the TI application report, *Implications of Slow or Floating CMOS Inputs*, literature number SCBA004.

**SN74LVTH32374-EP**  
**3.3-V ABT 32-BIT EDGE-TRIGGERED D-TYPE FLIP-FLOP**  
**WITH 3-STATE OUTPUTS**

SCBS795 – DECEMBER 2003

electrical characteristics over recommended operating free-air temperature range (unless otherwise noted)

PARAMETER		TEST CONDITIONS		MIN	TYP†	MAX	UNIT	
V <sub>IK</sub>		V <sub>CC</sub> = 2.7 V,	I <sub>I</sub> = -18 mA			-1.2	V	
V <sub>OH</sub>		V <sub>CC</sub> = 2.7 V to 3.6 V,	I <sub>OH</sub> = -100 μA	V <sub>CC</sub> -0.2			V	
		V <sub>CC</sub> = 2.7 V,	I <sub>OH</sub> = -8 mA	2.4				
		V <sub>CC</sub> = 3 V,	I <sub>OH</sub> = -32 mA	2				
V <sub>OL</sub>		V <sub>CC</sub> = 2.7 V	I <sub>OL</sub> = 100 μA			0.2	V	
			I <sub>OL</sub> = 24 mA			0.5		
		V <sub>CC</sub> = 3 V	I <sub>OL</sub> = 16 mA			0.4		
			I <sub>OL</sub> = 32 mA			0.5		
			I <sub>OL</sub> = 64 mA			0.55		
I <sub>I</sub>		V <sub>CC</sub> = 0 or 3.6 V,	V <sub>I</sub> = 5.5 V			10	μA	
		Control inputs	V <sub>CC</sub> = 3.6 V,	V <sub>I</sub> = V <sub>CC</sub> or GND				±1
		Data inputs	V <sub>CC</sub> = 3.6 V	V <sub>I</sub> = V <sub>CC</sub>				1
			V <sub>I</sub> = 0			-5		
I <sub>off</sub>		V <sub>CC</sub> = 0,	V <sub>I</sub> or V <sub>O</sub> = 0 to 4.5 V			±100	μA	
I <sub>I</sub> (hold)		V <sub>CC</sub> = 3 V	V <sub>I</sub> = 0.8 V	75			μA	
			V <sub>I</sub> = 2 V	-75				
		V <sub>CC</sub> = 3.6 V,‡	V <sub>I</sub> = 0 to 3.6 V			±500		
I <sub>OZH</sub>		V <sub>CC</sub> = 3.6 V,	V <sub>O</sub> = 3 V			5	μA	
I <sub>OZL</sub>		V <sub>CC</sub> = 3.6 V,	V <sub>O</sub> = 0.5 V			-5	μA	
I <sub>OZPU</sub>		V <sub>CC</sub> = 0 to 1.5 V, V <sub>O</sub> = 0.5 V to 3 V, $\overline{OE}$ = don't care				±100	μA	
I <sub>OZPD</sub>		V <sub>CC</sub> = 1.5 V to 0, V <sub>O</sub> = 0.5 V to 3 V, $\overline{OE}$ = don't care				±100	μA	
I <sub>CC</sub>		V <sub>CC</sub> = 3.6 V, I <sub>O</sub> = 0, V <sub>I</sub> = V <sub>CC</sub> or GND	Outputs high			0.38	mA	
			Outputs low			10		
			Outputs disabled			0.38		
ΔI <sub>CC</sub> §		V <sub>CC</sub> = 3 V to 3.6 V, One input at V <sub>CC</sub> - 0.6 V, Other inputs at V <sub>CC</sub> or GND				0.2	mA	
C <sub>i</sub>		V <sub>I</sub> = 3 V or 0				3	pF	
C <sub>o</sub>		V <sub>O</sub> = 3 V or 0				9	pF	

† All typical values are at V<sub>CC</sub> = 3.3 V, T<sub>A</sub> = 25°C.

‡ This is the bus-hold maximum dynamic current. It is the minimum overdrive current required to switch the input from one state to another.

§ This is the increase in supply current for each input that is at the specified TTL voltage level, rather than V<sub>CC</sub> or GND.

timing requirements over recommended operating free-air temperature range (unless otherwise noted) (see Figure 2)

		V <sub>CC</sub> = 3.3 ± 0.3 V		V <sub>CC</sub> = 2.7 V		UNIT
		MIN	MAX	MIN	MAX	
f <sub>clock</sub>	Clock frequency	160		160		MHz
t <sub>w</sub>	Pulse duration, CLK high or low	3		3		ns
t <sub>su</sub>	Setup time, data before CLK↑		High or low	1.8	2	ns
t <sub>h</sub>	Hold time, data after CLK↑		High or low	0.8	0.1	ns



**SN74LVTH32374-EP**  
**3.3-V ABT 32-BIT EDGE-TRIGGERED D-TYPE FLIP-FLOP**  
**WITH 3-STATE OUTPUTS**

SCBS795 – DECEMBER 2003

switching characteristics over recommended operating free-air temperature range (unless otherwise noted) (see Figure 2)

PARAMETER	FROM (INPUT)	TO (OUTPUT)	$V_{CC} = 3.3\text{ V}$ $\pm 0.3\text{ V}$			$V_{CC} = 2.7\text{ V}$		UNIT
			MIN	TYP†	MAX	MIN	MAX	
$f_{\max}$			160			160		MHz
$t_{PLH}$	CLK	Q	1.9	3	4.5		5.2	ns
$t_{PHL}$			2.1	2.9	4		4.2	
$t_{PZH}$	$\overline{OE}$	Q	1.5	2.8	4.5		5.4	ns
$t_{PZL}$			1.5	2.8	4.4		5	
$t_{PHZ}$	$\overline{OE}$	Q	2.4	3.5	5		5.4	ns
$t_{PLZ}$			2	3.2	4.6		4.8	
$t_{sk(o)}$					0.5			ns

† All typical values are at  $V_{CC} = 3.3\text{ V}$ ,  $T_A = 25^\circ\text{C}$ .

**SN74LVTH32374-EP**  
**3.3-V ABT 32-BIT EDGE-TRIGGERED D-TYPE FLIP-FLOP**  
**WITH 3-STATE OUTPUTS**

SCBS795 – DECEMBER 2003

**PARAMETER MEASUREMENT INFORMATION**

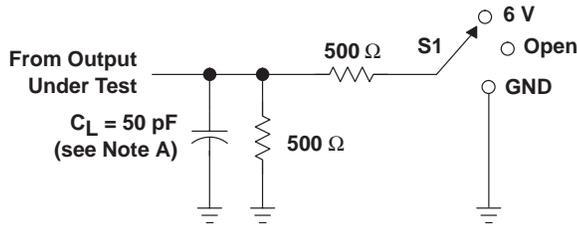

**LOAD CIRCUIT**

TEST	S1
$t_{PLH}/t_{PHL}$	Open
$t_{PLZ}/t_{PZL}$	6 V
$t_{PHZ}/t_{PZH}$	GND

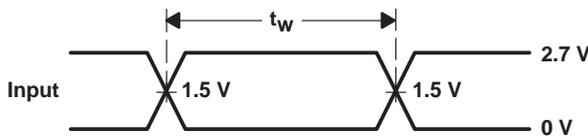

**VOLTAGE WAVEFORMS**  
**PULSE DURATION**

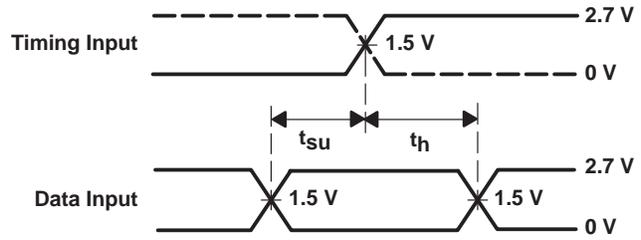

**VOLTAGE WAVEFORMS**  
**SETUP AND HOLD TIMES**

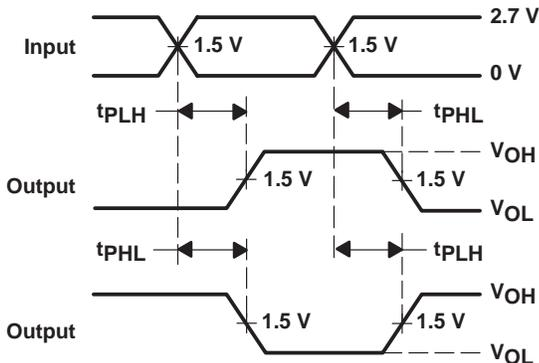

**VOLTAGE WAVEFORMS**  
**PROPAGATION DELAY TIMES**  
**INVERTING AND NONINVERTING OUTPUTS**

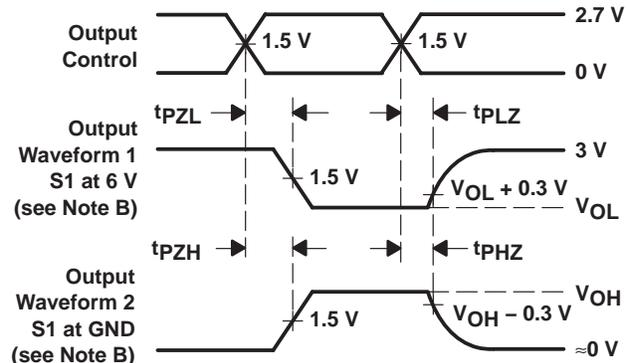

**VOLTAGE WAVEFORMS**  
**ENABLE AND DISABLE TIMES**  
**LOW- AND HIGH-LEVEL ENABLING**

- NOTES: A.  $C_L$  includes probe and jig capacitance.  
 B. Waveform 1 is for an output with internal conditions such that the output is low except when disabled by the output control. Waveform 2 is for an output with internal conditions such that the output is high except when disabled by the output control.  
 C. All input pulses are supplied by generators having the following characteristics:  $PRR \leq 10$  MHz,  $Z_O = 50 \Omega$ ,  $t_r \leq 2.5$  ns,  $t_f \leq 2.5$  ns.  
 D. The outputs are measured one at a time with one transition per measurement.  
 E. All parameters and waveforms are not applicable to all devices.

**Figure 2. Load Circuit and Voltage Waveforms**

**PACKAGING INFORMATION**

Orderable Device	Status (1)	Package Type	Package Drawing	Pins	Package Qty	Eco Plan (2)	Lead/Ball Finish (6)	MSL Peak Temp (3)	Op Temp (°C)	Device Marking (4/5)	Samples
CLVTH32374IGKEREP	LIFEBUY	LFBGA	GKE	96	1000	TBD	SNPB	Level-3-220C-168 HR	-40 to 85	L374EP	
V62/04722-01XA	LIFEBUY	LFBGA	GKE	96	1000	TBD	SNPB	Level-3-220C-168 HR	-40 to 85	L374EP	

(1) The marketing status values are defined as follows:

**ACTIVE:** Product device recommended for new designs.

**LIFEBUY:** TI has announced that the device will be discontinued, and a lifetime-buy period is in effect.

**NRND:** Not recommended for new designs. Device is in production to support existing customers, but TI does not recommend using this part in a new design.

**PREVIEW:** Device has been announced but is not in production. Samples may or may not be available.

**OBsolete:** TI has discontinued the production of the device.

(2) **RoHS:** TI defines "RoHS" to mean semiconductor products that are compliant with the current EU RoHS requirements for all 10 RoHS substances, including the requirement that RoHS substance do not exceed 0.1% by weight in homogeneous materials. Where designed to be soldered at high temperatures, "RoHS" products are suitable for use in specified lead-free processes. TI may reference these types of products as "Pb-Free".

**RoHS Exempt:** TI defines "RoHS Exempt" to mean products that contain lead but are compliant with EU RoHS pursuant to a specific EU RoHS exemption.

**Green:** TI defines "Green" to mean the content of Chlorine (Cl) and Bromine (Br) based flame retardants meet JS709B low halogen requirements of <=1000ppm threshold. Antimony trioxide based flame retardants must also meet the <=1000ppm threshold requirement.

(3) MSL, Peak Temp. - The Moisture Sensitivity Level rating according to the JEDEC industry standard classifications, and peak solder temperature.

(4) There may be additional marking, which relates to the logo, the lot trace code information, or the environmental category on the device.

(5) Multiple Device Markings will be inside parentheses. Only one Device Marking contained in parentheses and separated by a "~" will appear on a device. If a line is indented then it is a continuation of the previous line and the two combined represent the entire Device Marking for that device.

(6) Lead/Ball Finish - Orderable Devices may have multiple material finish options. Finish options are separated by a vertical ruled line. Lead/Ball Finish values may wrap to two lines if the finish value exceeds the maximum column width.

**Important Information and Disclaimer:** The information provided on this page represents TI's knowledge and belief as of the date that it is provided. TI bases its knowledge and belief on information provided by third parties, and makes no representation or warranty as to the accuracy of such information. Efforts are underway to better integrate information from third parties. TI has taken and continues to take reasonable steps to provide representative and accurate information but may not have conducted destructive testing or chemical analysis on incoming materials and chemicals. TI and TI suppliers consider certain information to be proprietary, and thus CAS numbers and other limited information may not be available for release.

In no event shall TI's liability arising out of such information exceed the total purchase price of the TI part(s) at issue in this document sold by TI to Customer on an annual basis.

**OTHER QUALIFIED VERSIONS OF SN74LVTH32374-EP :**

- Catalog: [SN74LVTH32374](#)

NOTE: Qualified Version Definitions:

- Catalog - TI's standard catalog product

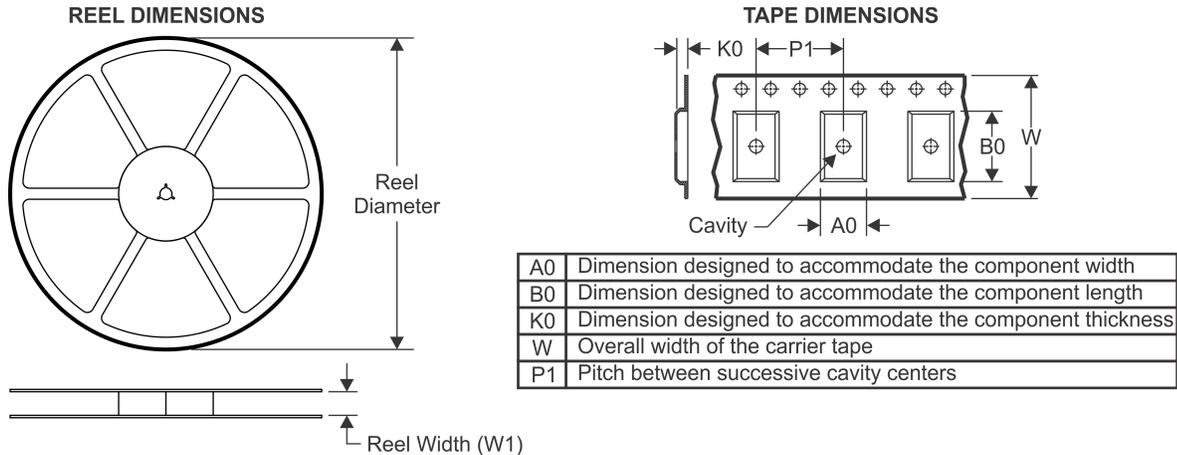
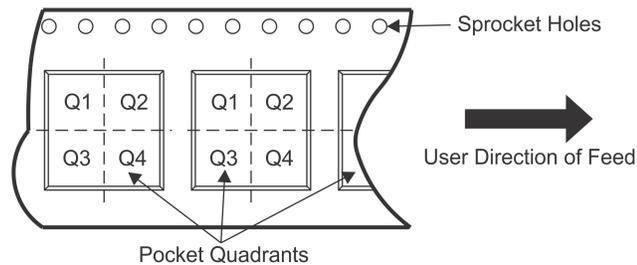
**TAPE AND REEL INFORMATION**

**QUADRANT ASSIGNMENTS FOR PIN 1 ORIENTATION IN TAPE**

\*All dimensions are nominal

Device	Package Type	Package Drawing	Pins	SPQ	Reel Diameter (mm)	Reel Width W1 (mm)	A0 (mm)	B0 (mm)	K0 (mm)	P1 (mm)	W (mm)	Pin1 Quadrant
CLVTH32374IGKEREP	LFBGA	GKE	96	1000	330.0	24.4	5.7	13.7	2.0	8.0	24.0	Q1

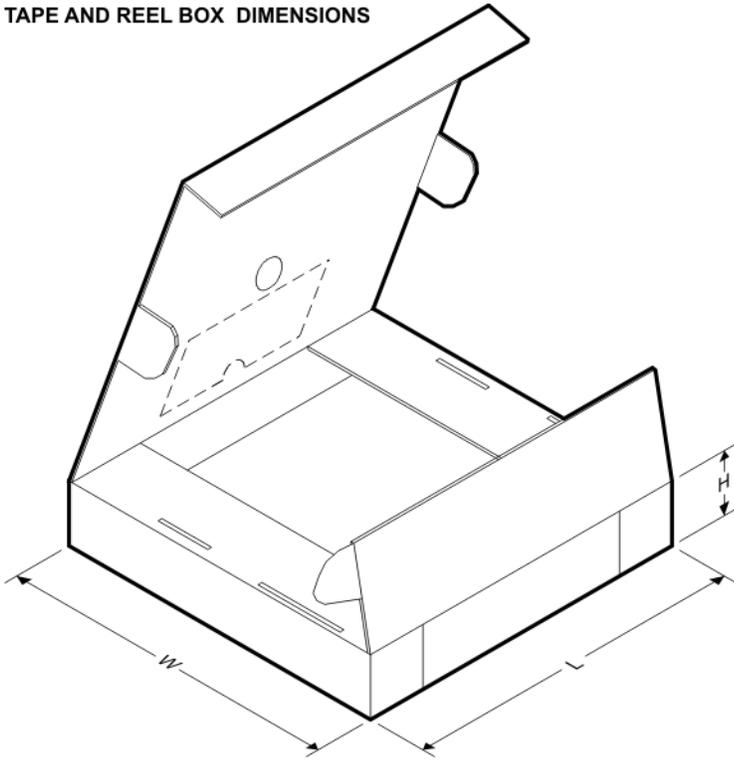
**TAPE AND REEL BOX DIMENSIONS**



\*All dimensions are nominal

Device	Package Type	Package Drawing	Pins	SPQ	Length (mm)	Width (mm)	Height (mm)
CLVTH32374IGKEREP	LFBGA	GKE	96	1000	336.6	336.6	41.3

GKE (R-PBGA-N96)

PLASTIC BALL GRID ARRAY

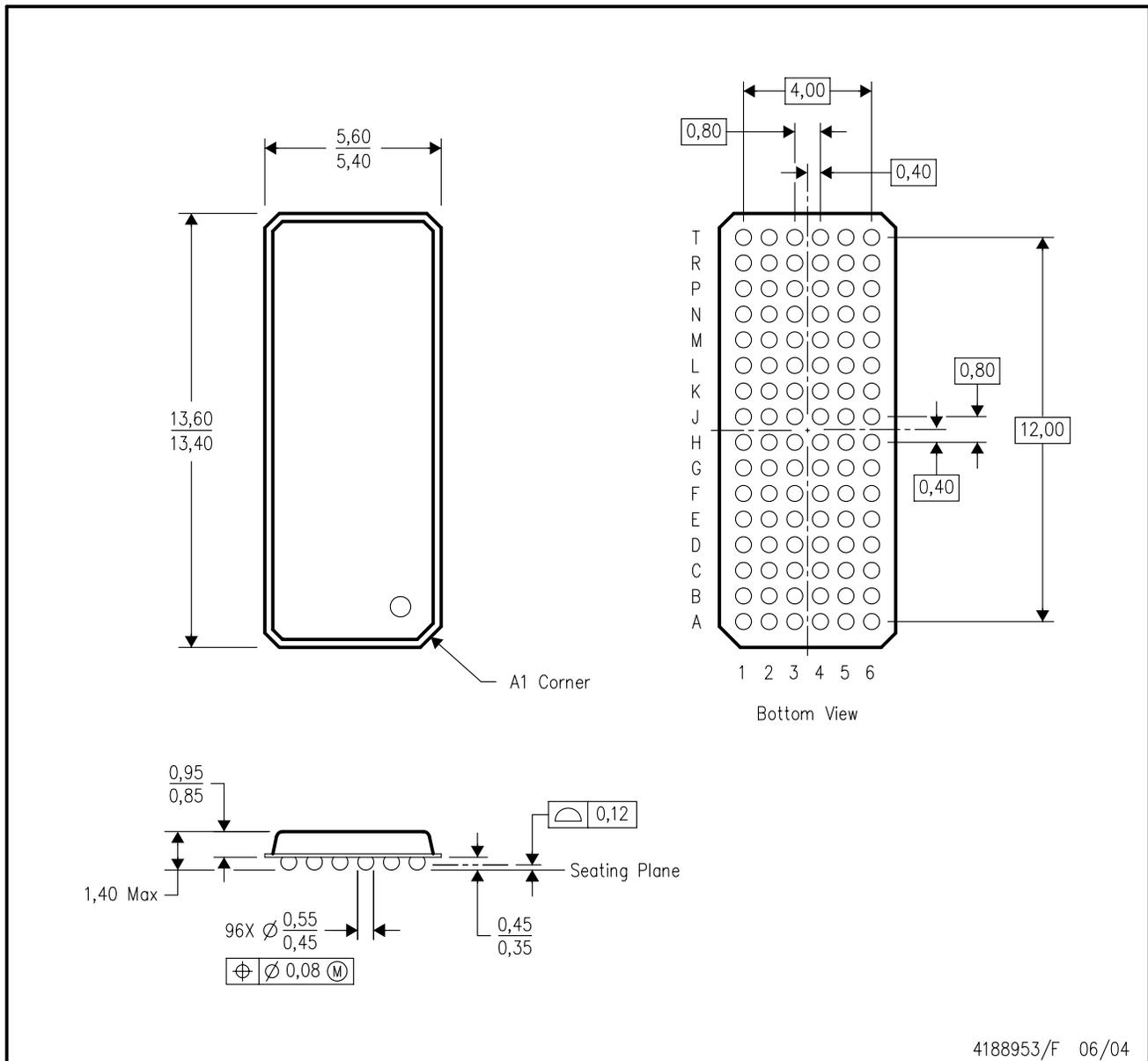

- NOTES:
- A. All linear dimensions are in millimeters.
  - B. This drawing is subject to change without notice.
  - C. Falls within JEDEC MO-205 variation CC.
  - D. This package is tin-lead (SnPb). Refer to the 96 ZKE package (drawing 4204493) for lead-free.

## IMPORTANT NOTICE AND DISCLAIMER

TI PROVIDES TECHNICAL AND RELIABILITY DATA (INCLUDING DATASHEETS), DESIGN RESOURCES (INCLUDING REFERENCE DESIGNS), APPLICATION OR OTHER DESIGN ADVICE, WEB TOOLS, SAFETY INFORMATION, AND OTHER RESOURCES "AS IS" AND WITH ALL FAULTS, AND DISCLAIMS ALL WARRANTIES, EXPRESS AND IMPLIED, INCLUDING WITHOUT LIMITATION ANY IMPLIED WARRANTIES OF MERCHANTABILITY, FITNESS FOR A PARTICULAR PURPOSE OR NON-INFRINGEMENT OF THIRD PARTY INTELLECTUAL PROPERTY RIGHTS.

These resources are intended for skilled developers designing with TI products. You are solely responsible for (1) selecting the appropriate TI products for your application, (2) designing, validating and testing your application, and (3) ensuring your application meets applicable standards, and any other safety, security, or other requirements. These resources are subject to change without notice. TI grants you permission to use these resources only for development of an application that uses the TI products described in the resource. Other reproduction and display of these resources is prohibited. No license is granted to any other TI intellectual property right or to any third party intellectual property right. TI disclaims responsibility for, and you will fully indemnify TI and its representatives against, any claims, damages, costs, losses, and liabilities arising out of your use of these resources.

TI's products are provided subject to TI's Terms of Sale ([www.ti.com/legal/termsofsale.html](http://www.ti.com/legal/termsofsale.html)) or other applicable terms available either on [ti.com](http://ti.com) or provided in conjunction with such TI products. TI's provision of these resources does not expand or otherwise alter TI's applicable warranties or warranty disclaimers for TI products.

Mailing Address: Texas Instruments, Post Office Box 655303, Dallas, Texas 75265  
Copyright © 2020, Texas Instruments Incorporated