

April 1995

30A, 100V - 200V Ultrafast Diodes

Features

- Ultrafast with Soft Recovery Characteristic ($t_{RR} < 45ns$)
- +175°C Rated Junction Temperature
- Reverse Voltage Up to 200V
- Avalanche Energy Rated

Applications

- Switching Power Supply
- Power Switching Circuits
- General Purpose

Description

RURP3010, RURP3015, RURP3020 are ultrafast diodes ($t_{RR} < 45ns$) with soft recovery characteristics. They have a low forward voltage drop and are of planar, silicon nitride passivated, ion-implanted, epitaxial construction.

These devices are intended for use as energy steering/clamping diodes and rectifiers in a variety of switching power supplies and other power switching applications. Their low stored charge and ultrafast recovery with soft recovery characteristics minimizes ringing and electrical noise in many power switching circuits thus reducing power loss in the switching transistor.

PACKAGING AVAILABILITY

PART NUMBER	PACKAGE	BRAND
RURP3010	TO-220AC	RURP3010
RURP3015	TO-220AC	RURP3015
RURP3020	TO-220AC	RURP3020

NOTE: When ordering, use the entire part number.

Package

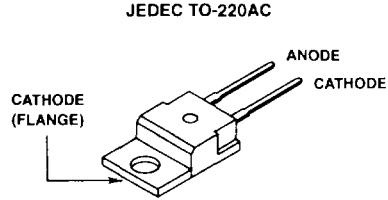

Symbol



Absolute Maximum Ratings $T_C = +25^\circ C$, Unless Otherwise Specified

	RURP3010	RURP3015	RURP3020
Peak Repetitive Reverse Voltage..... V_{RRM}	100V	150V	200V
Working Peak Reverse Voltage..... V_{RWM}	100V	150V	200V
DC Blocking Voltage..... V_R	100V	150V	200V
Average Rectified Forward Current..... $I_{F(AV)}$ (Total Device Forward Current At Rated V_R and $T_C = +150^\circ C$)	30A	30A	30A
Peak Forward Repetitive Current..... I_{FRM} (Rated V_R , Square Wave 20kHz)	70A	70A	70A
Nonrepetitive Peak Surge Current..... I_{FSM} (Surge Applied At Rated Load Condition Halfwave 1 Phase 60Hz)	325A	325A	325A
Operating and Storage Temperature..... T_{STG}, T_J	-55°C to +175°C	-55°C to +175°C	-55°C to +175°C

5
ULTRAFAST
SINGLE DIODES

Specifications RURP3010, RURP3015, RURP3020

Electrical Specifications $T_C = +25^\circ\text{C}$, Unless Otherwise Specified.

SYMBOL	TEST CONDITION	LIMITS									UNITS
		RURP3010			RURP3015			RURP3020			
		MIN	TYP	MAX	MIN	TYP	MAX	MIN	TYP	MAX	
V_F	$I_F = 30\text{A}$ $T_C = +150^\circ\text{C}$	-	-	0.85	-	-	0.85	-	-	0.85	V
	$I_F = 30\text{A}$ $T_C = +25^\circ\text{C}$	-	-	1.00	-	-	1.00	-	-	1.00	V
I_R at $T_C = +150^\circ\text{C}$	$V_R = 100\text{V}$	-	-	1.0	-	-	-	-	-	-	mA
	$V_R = 150\text{V}$	-	-	-	-	-	1.0	-	-	-	mA
	$V_R = 200\text{V}$	-	-	-	-	-	-	-	-	1.0	mA
I_R at $T_C = +25$	$V_R = 100\text{V}$	-	-	500	-	-	-	-	-	-	μA
	$V_R = 150\text{V}$	-	-	-	-	-	500	-	-	-	μA
	$V_R = 200\text{V}$	-	-	-	-	-	-	-	-	500	μA
t_{RR}	$I_F = 1\text{A}$	-	-	45	-	-	45	-	-	45	ns
	$I_F = 30\text{A}$	-	-	50	-	-	50	-	-	50	ns
t_A	$I_F = 1\text{A}$	-	24	-	-	24	-	-	24	-	ns
	$I_F = 30\text{A}$	-	28	-	-	28	-	-	28	-	ns
t_B	$I_F = 1\text{A}$	-	17	-	-	17	-	-	17	-	ns
	$I_F = 30\text{A}$	-	20	-	-	20	-	-	20	-	ns
$R_{\theta JC}$		-	-	1.2	-	-	1.2	-	-	1.2	$^\circ\text{C/W}$
E_{AVL}	See Figures 7 and 8	-	-	20	-	-	20	-	-	20	mJ

DEFINITIONS

V_F = Instantaneous forward voltage ($p_w = 300\mu\text{s}$, $D = 2\%$).

I_R = Instantaneous reverse current.

t_{RR} = Reverse recovery time at $dI_F/dt = 100\text{A}/\mu\text{s}$ (See Figure 2), summation of $t_A + t_B$.

t_A = Time to reach peak reverse current at $dI_F/dt = 100\text{A}/\mu\text{s}$ (See Figure 2).

t_B = Time from peak I_{RM} to projected zero crossing of I_{RM} based on a straight line from peak I_{RM} through 25% of I_{RM} (See Figure 2).

$R_{\theta JC}$ = Thermal resistance junction to case.

E_{AVL} = Controlled avalanche energy (See Figures 7 and 8).

p_w = pulse width.

D = duty cycle.

V_1 AMPLITUDE CONTROLS I_F
 V_2 AMPLITUDE CONTROLS dI_F/dt
 L_1 = SELF INDUCTANCE OF
 $R_4 + L_{\text{LOOP}}$

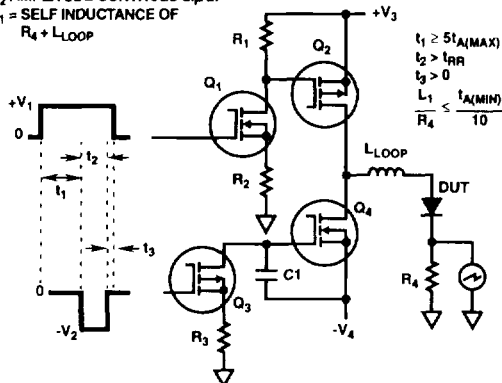

FIGURE 1. t_{RR} TEST CIRCUIT

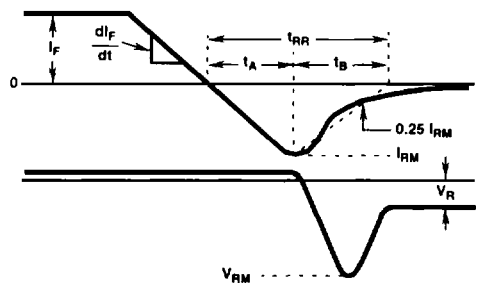

FIGURE 2. t_{RR} WAVEFORMS AND DEFINITIONS

Typical Performance Curves

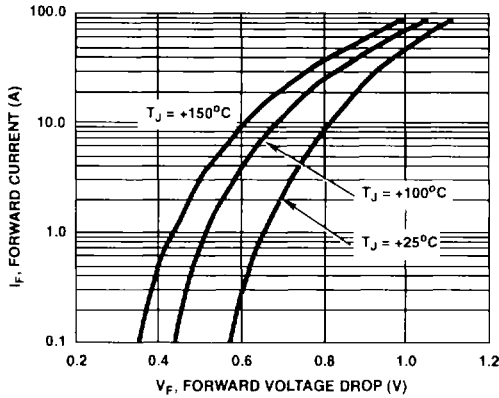

FIGURE 3. FORWARD VOLTAGE vs FORWARD CURRENT CHARACTERISTIC

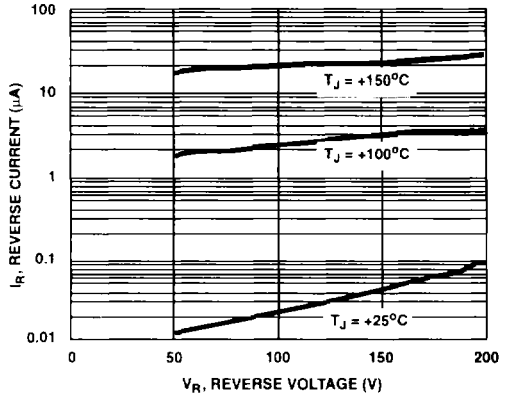

FIGURE 4. REVERSE VOLTAGE vs REVERSE CURRENT CHARACTERISTIC

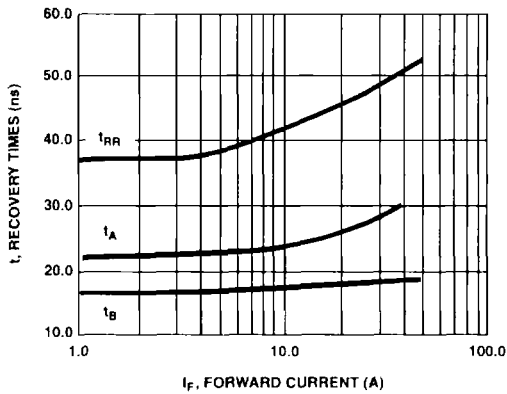

FIGURE 5. TYPICAL t_{RR} , t_A AND t_B CURVES vs FORWARD CURRENT

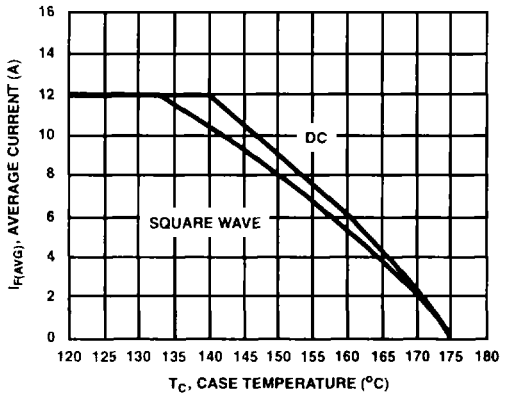

FIGURE 6. TYPICAL CURRENT DERATING CURVE vs CASE TEMPERATURE

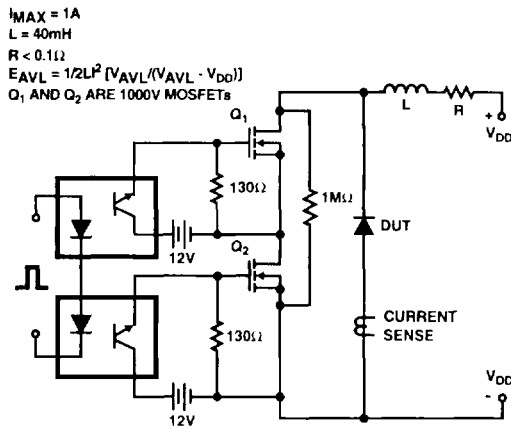

FIGURE 7. AVALANCHE ENERGY TEST CIRCUIT

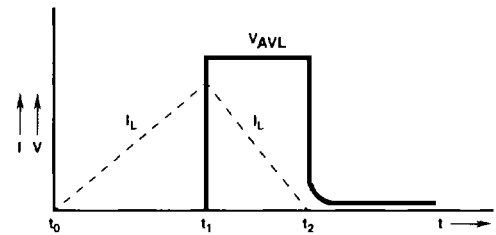

FIGURE 8. AVALANCHE CURRENT AND VOLTAGE WAVEFORMS

$$I_{L\text{peak}} = 1A, L = 40mH, R < 0.1\Omega, E_{AVL} = (\frac{1}{2}) L I^2 [V_{AVL} / (V_{AVL} - V_{DD})]$$